

INSTRUCTION MANUAL

Serial Number _____

**7A15A/AN
AMPLIFIER**

Scans By *Artek Media*

Artek Media
1042 Plummer Cir. SW
Rochester, MN 55902

www.artekmedia.com

“High resolution scans of obsolete technical manuals”

If your looking for a quality scanned technical manual in PDF format please visit our WEB site at www.artekmedia.com or drop us an email at manuals@artekmedia.com and we will be happy to email you a current list of the manuals we have available.

If you don't see the manual you need on the list drop us a line anyway we may still be able to point you to other sources. If you have an existing manual you would like scanned please write for details, This can often be done very reasonably in consideration for adding your manual to our library.

Typically the scans in our manuals are done as follows;

- 1) Typed text pages are typically scanned in black and white at 300 dpi.
- 2) Photo pages are typically scanned in gray scale mode at 600 dpi
- 3) Schematic diagram pages are typically scanned in black and white at 600 dpi unless the original manual had colored high lighting (as is the case for some 70's vintage Tektronix manuals).

If you purchased this manual from us (typically through our Ebay name of ArtekMedia) thank you very much. If you received this from a well-meaning “friend” for free we would appreciate your treating this much like you would “share ware”. By that we mean a donation of at least \$5-10 per manual is appreciated in recognition of the time (a manual can take as much as 40 hours to reproduce, book, link etc.), energy and quality of effort that went into preserving this manual. Donations via PayPal go to: manuals@artekmedia.com or can be mailed to us the address above.

Thanks



Dave & Lynn Henderson
Artek Media

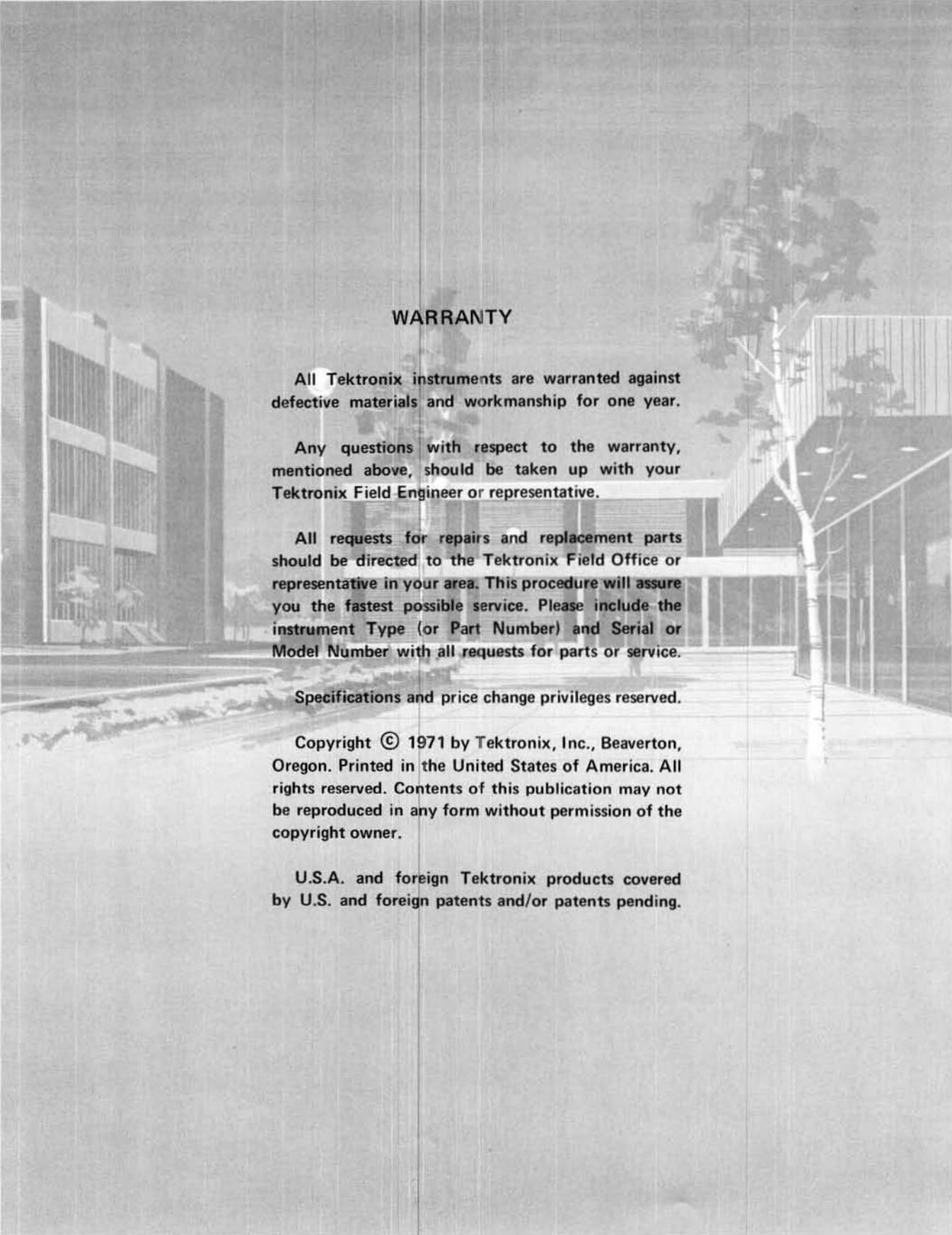

WARRANTY

All Tektronix instruments are warranted against defective materials and workmanship for one year.

Any questions with respect to the warranty, mentioned above, should be taken up with your Tektronix Field Engineer or representative.

All requests for repairs and replacement parts should be directed to the Tektronix Field Office or representative in your area. This procedure will assure you the fastest possible service. Please include the instrument Type (or Part Number) and Serial or Model Number with all requests for parts or service.

Specifications and price change privileges reserved.

Copyright © 1971 by Tektronix, Inc., Beaverton, Oregon. Printed in the United States of America. All rights reserved. Contents of this publication may not be reproduced in any form without permission of the copyright owner.

U.S.A. and foreign Tektronix products covered by U.S. and foreign patents and/or patents pending.

TABLE OF CONTENTS

SECTION 1	SPECIFICATION	Page	SECTION 5	CALIBRATION	Page
	Introduction	1-1		Introduction	5-1
	Electrical Characteristics	1-1		Test Equipment Required	5-1
	Environmental Characteristics	1-2		Performance Check Procedure	5-2
	Physical Characteristics	1-2		Calibration Procedure	5-2
SECTION 2	OPERATING INSTRUCTIONS		SECTION 6	ELECTRICAL PARTS LIST	
	Installation	2-1		Abbreviations and Symbols	
	Controls and Connectors	2-1		Parts Ordering Information	
	Basic Operation	2-2	SECTION 7	DIAGRAMS AND CIRCUIT BOARD	
	General Operating Information	2-2		ILLUSTRATIONS	
	Applications	2-3		Symbols and Reference Designators	
SECTION 3	CIRCUIT DESCRIPTION		SECTION 8	MECHANICAL PARTS LIST	
	Introduction	3-1		Mechanical Parts List Information	
	Block Diagram Description	3-1		Index of Mechanical Parts	
	Detailed Circuit Description	3-1		Illustrations	
SECTION 4	MAINTENANCE			Mechanical Parts List	
	Preventive Maintenance	4-1			
	Troubleshooting	4-1			
	Corrective Maintenance	4-3			

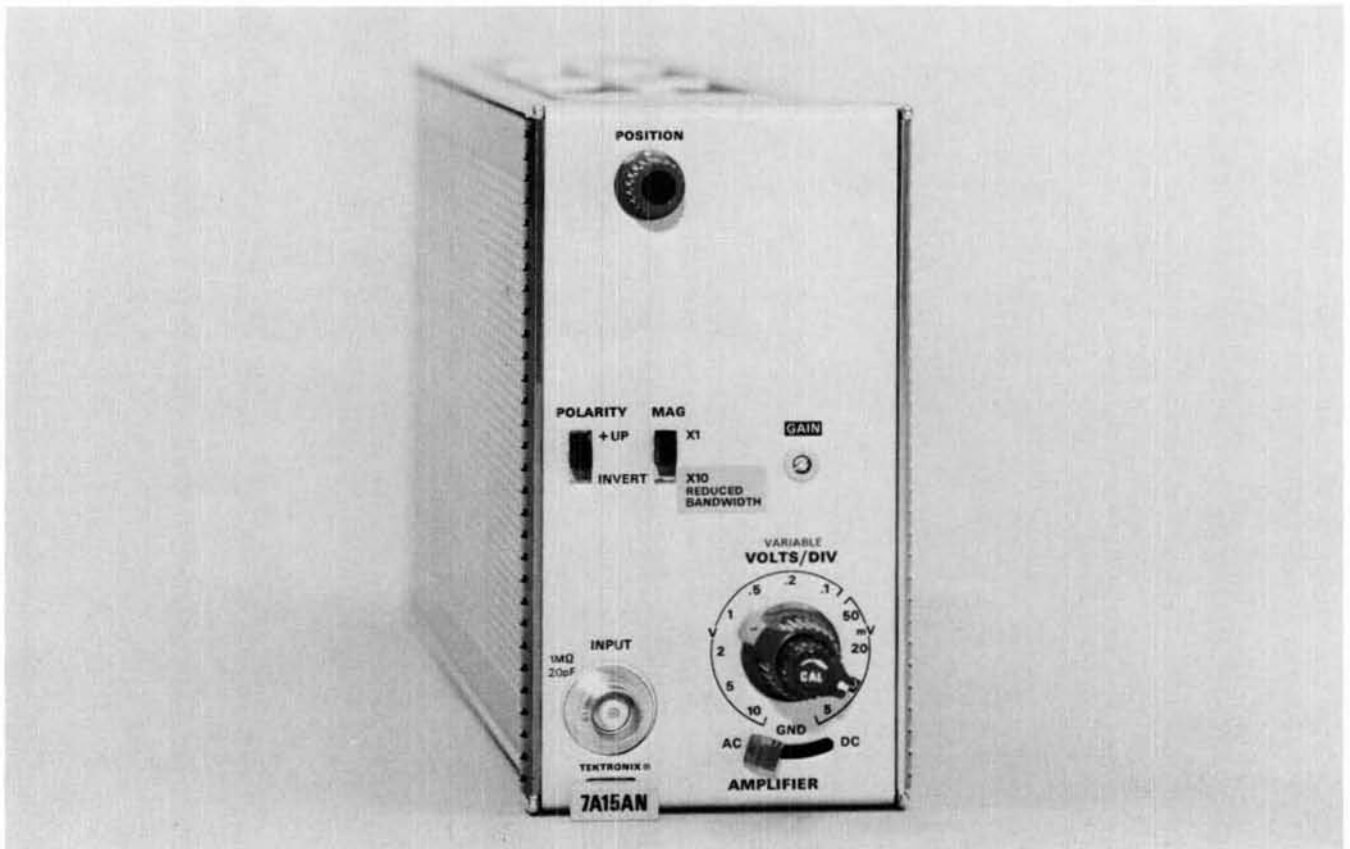
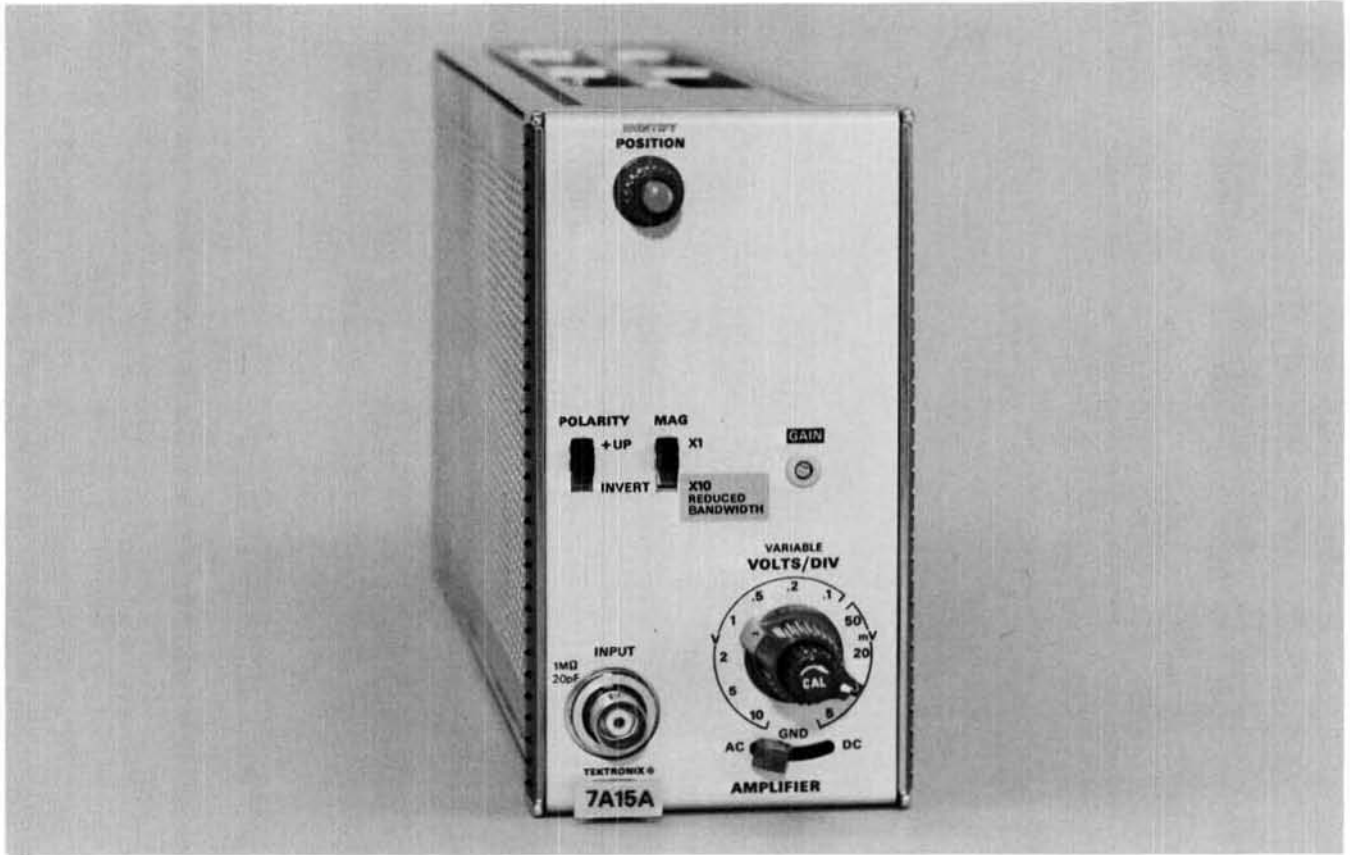

Fig. 1-1. 7A15A and 7A15AN Amplifier.

SECTION 1

SPECIFICATION

Introduction

The 7A15A/7A15AN Amplifier plug-in unit is a wide band amplifier designed for use with Tektronix 7000-Series oscilloscopes. The 7A15A and 7A15AN are electrically identical except that encoding capabilities and an "IDENTIFY" function are provided in the 7A15A. The

7A15A/7A15AN can be operated in any plug-in compartment of 7000-Series oscilloscopes.

The following electrical characteristics are valid over the stated environmental range for instruments calibrated at an ambient temperature of +20°C to +30°C, and after a five minute warmup unless otherwise noted.

TABLE 1-1
ELECTRICAL

Characteristic	Performance Requirement		Supplemental Information
Deflection Factor			
Calibrated Range	5 mV/Div to 10 V/Div, 11 steps in a 1-2-5 sequence		
Deflection Factor Accuracy	Within 2% of indicated deflection factor with GAIN adjusted at 10 mV/Div		
Uncalibrated (VARIABLE)	Continuously variable between calibrated steps; extends deflection factor to at least 25 V/Div		
X10 GAIN	Increases amplifier gain by a factor of 10 within 10%, decreasing deflection factor to 500 μ V/Div		
Frequency Response			
Upper Bandwidth Frequency (at -3 dB)			
X1 (System Dependent)	With 7900-series 80 MHz	With 7700-series 75 MHz	
	With 7500-series 60 MHz	With 7400-series 50 MHz	
X10	10 MHz		
Low-Frequency Response	10 Hz or less without probe		
(Lower -3 dB point) AC (Capacitive) coupled	1 Hz or less with probe		

TABLE 1-1 (cont)

Characteristic	Performance Requirement	Supplemental Information
Maximum Input Voltage DC Coupled		250 V (DC + Peak AC); AC component 500 V P-P maximum, 1 kHz or less
AC Coupled		500 V (DC + Peak AC); AC component 500 V P-P maximum, 1 kHz or less
Input R and C Resistance	1 MΩ ± 2%	
Capacitance	Approximately 20.0 pf	
RC Tolerance		Within ± 1% between all deflection factors.
Overdrive Recovery Time		0.1 ms or less to recover to within one division after removal of overdrive signal of up to +75 divisions to -75 divisions regardless of overdrive signal duration

TABLE 1-2

ENVIRONMENTAL CHARACTERISTICS

Refer to the specifications for the associated oscilloscope

TABLE 1-3

PHYSICAL

Size	Fits all 7000-series plug-in compartments
Weight	1 pound 13 ounces (0.82 kilogram)

SECTION 2

OPERATING INSTRUCTIONS

General

To effectively use the 7A15A/7A15AN, the operation and capabilities of the instrument must be known. This section describes front-panel control functions, general information on signal input connections, and other subjects that pertain to various measurement applications.

Installation

The 7A15A/7A15AN is calibrated and ready for use as received. It can be installed in any compartment of Tektronix 7000-Series Oscilloscopes, but is intended for use primarily in vertical plug-in compartments. To install, align the upper and lower rails of the 7A15A/7A15AN with the oscilloscope tracks and insert the plug-in. The front panel will be flush with the front of the oscilloscope when the 7A15A/7A15AN is fully inserted, and the latch at the bottom-left corner will be in place against the front panel.

To remove the 7A15A/7A15AN, pull on the latch (which is inscribed with the unit identification "7A15A" or "7A15AN") and the 7A15A/7A15AN will unlatch. Continue pulling on the latch to slide the 7A15A/7A15AN out of the oscilloscope.

FRONT PANEL CONTROLS AND CONNECTORS

VOLTS/DIV Selects calibrated deflection factors from 5 mV/Div to 10 V/Div; 11 steps in a 1-2-5 sequence.

VARIABLE Provides continuously variable uncalibrated settings between calibrated steps. Extends the deflection factor range to 25 volts/division or more.

GAIN Adjustment Screwdriver adjustment permits calibration of deflection factor.

POLARITY Provides means of inverting the display.

+UP: A positive-going signal at the Input connector deflects the CRT display upward.

INVERT: A positive-going signal at the Input connector deflects the CRT display downward.

MAG

Provides means of decreasing the deflection factor.

X1: Deflection factor is that selected by VOLTS/DIV and VARIABLE controls.

X10 REDUCED BANDWIDTH: Deflection factor is one-tenth of the value selected by the VOLTS/DIV and VARIABLE controls.

Input Connector

Provides signal connection to the amplifier.

AC-GND-DC

Selects signal input coupling mode.

AC: The AC component of the signal is coupled to the amplifier input, while the DC component is blocked.

DC: Both AC and DC components of the signal are coupled to the amplifier input.

GND: Grounds the amplifier input while maintaining the same load for the input signal. Provides a charge path for the AC coupling capacitor to pre-charge the input circuit before switching the input to AC.

POSITION

Controls position of the trace.

IDENTIFY
(7A15A Only)

Deflects trace about 0.3 division for trace identification. In instruments with readout, also replaces readout with the word "IDENTIFY".

BASIC OPERATION

General. This procedure demonstrates the use of the connectors and controls of the 7A15A/7A15AN, while at the same time providing a means of checking the basic operation of the instrument.

Preliminary Setup. Install the 7A15A/7A15AN into any 7000-series oscilloscope vertical compartment and set the oscilloscope VERTICAL MODE and TRIGGER SOURCE to the proper settings.

Install a 7-series time-base unit into a horizontal compartment and set the oscilloscope HORIZONTAL MODE to the proper setting. Set the time-base unit to a sweep rate of one-millisecond per division and set the triggering mode to AUTO.

Procedure

1. Set the 7A15A/7A15AN AC-GND-DC switch to GND and position the trace to the center of the graticule.
2. Set the VOLTS/DIV switch to 10 mV and apply a 40 mV 1 kHz square-wave signal from the oscilloscope CALIBRATOR to the 7A15A/7A15AN INPUT connector. Set the AC-GND-DC switch to DC and check for a four-division display.
3. Set POLARITY switch to INVERT and check that the displayed signal is inverted as compared to its appearance in step 2.
4. Set the AC-GND-DC switch to AC and check that the trace is centered on the CRT graticule.
5. Set the oscilloscope CALIBRATOR to 4 mV and the 7A15A/7A15AN MAG switch to X10. Check for a four-division display.
6. (7A15A Only) Press the 7A15A IDENTIFY button, check that the display moves upward approximately 0.3 division and the readout (if so equipped) reads "IDENTIFY".

GENERAL OPERATING INFORMATION

Signal Connections

In general, probes offer the most convenient means of connecting a signal to the input of the 7A15A/7A15AN. A 10X attenuator probe offers a high impedance and allows

the circuit under test to perform very close to normal operating conditions.

The Tektronix P6053 probe is equipped with a readout coding ring which connects to a circuit in the amplifier unit. This automatically corrects the readout displayed on the CRT to the actual deflection factor at the tip of the probe. This probe is recommended for use with the 7A15A and an oscilloscope equipped with readout. The Tektronix P6054 probe is electrically identical to the P6053 but is intended for use with systems not equipped with readout. For more information refer to the Tektronix Inc. catalog.

Vertical Gain Check and Adjustment

To check the gain of the 7A15A/7A15AN, set the VOLTS/DIV switch to 10 mV and connect a 40 mV, 1 kHz signal from the oscilloscope calibrator to the Input connector. The vertical deflection should be exactly four divisions. If not, adjust the front panel GAIN for exactly four divisions.

Input Coupling

The AC-GND-DC switch allows a choice of input coupling methods. The type of display desired and the applied signal will determine the coupling to use.

The DC coupling position can be used for most applications. For AC signals with frequencies below about 30 Hz (10 Hz with a 10X probe), and square waves whose low-frequency components are important to the display, it is necessary to use DC coupling to obtain a satisfactory presentation.

In the AC coupling position the DC component of the signal is blocked by a capacitor in the input circuit. The AC coupling position provides the best display of signals with a DC component much larger than the AC component. The pre-charge feature should be used when there is a possibility of having a residual charge on the input capacitor of the opposite polarity to the intended input, and when the algebraic sum of the combination of charges may be greater than the maximum input limitations of the amplifier. To use this feature, first set the coupling switch to GND, then connect the probe to the circuit and wait about two seconds for the coupling capacitor to charge, set the coupling switch to AC.

The GND position provides a ground reference at the input of the amplifier without externally grounding the Input connectors. However, the signal connected to the input is not grounded, and the same DC load is presented to the signal source.

VOLTS/DIV, VARIABLE and MAG Controls

The amount of deflection produced by a signal is determined by the signal amplitude, the attenuation factor of the probe, the setting of the VOLTS/DIV switch, the setting of the VARIABLE Control, and the setting of the MAG switch. Calibrated deflection factors represented by the setting of the VOLTS/DIV switch apply only when the VARIABLE control is in the CAL position (fully clockwise) and when the MAG switch is set to X1.

The VARIABLE control provides variable uncalibrated settings between the calibrated steps of the VOLTS/DIV switch. With the VARIABLE control set fully counter-clockwise and the VOLTS/DIV switch set to 5 volts/div, the uncalibrated deflection factor is extended to at least 2.5 times the attenuator setting. By applying a calibrated voltage source to the Input connector, any specific deflection factor can be set within the range of the VARIABLE control.

The MAG switch increases the VOLTS/DIV switch sensitivity by a factor of 10 when in the X10 position. Thus, with the MAG switch set to X10 and the VOLTS/DIV switch set to 5 mV/div, the deflection factor is extended to 500 μ V/div. The MAG switch also effects a circuit in the 7A15A which corrects the readout. With the MAG switch set to X10, the bandwidth of the amplifier is reduced. Refer to specifications in Section 1.

Polarity Switch

The POLARITY switch provides a means of inverting the displayed signal. With the POLARITY set to +UP, a positive-going signal at the INPUT produces an upward deflection of the CRT display. With the POLARITY set to INVERT, a positive-going signal will produce a downward deflection of the CRT display.

Trace Identification (7A15A only)

When the IDENTIFY button is pressed, the trace is deflected upward about 0.3 division to identify the 7A15A trace. This feature is particularly useful when multiple traces are displayed on the CRT. In mainframes with readout, it also replaces the deflection factor readout with the word "IDENTIFY".

When using a 100X readout coded probe such as a P6009 (Tektronix Part No. 010-0264-01), the 7A15A encoding of CRT readout is incorrect for a number of VOLTS/DIV settings. These incorrect readings occur with the MAG switch in the 1X gain position as follows: Actual: 50mV, 10V, 20V and 1S, should read: 500mV, 100V, 200V and 1kV. If a 100X probe is to be used with the 7A15A at these sensitivities, in a CRT readout mainframe, it might be preferable to defeat the probe coding and multiply the plug-in VOLTS/DIV by a factor of 100 as in non-coded operation. Possible means for achieving this is; use a P6009 Tektronix Part No. 010-0170-00 (no readout connector), defeat the probe coding connection in the 7A15A by disconnecting R48, defeat the CRT readout entirely for the 7A15A by unsoldering the A37 and B37 cable connections between the readout EC board and the mainframe EC board.

APPLICATIONS

General

The following information describes the procedures and techniques for making measurements with a 7A15A/7A15AN and the associated Tektronix oscilloscope and time-base. These applications are not described in detail, since each application must be adapted to the requirements of the individual measurements. This instrument can also be used for many applications which are not described in this manual. Contact your local Tektronix Field Office or representative for assistance in making specific measurements with this instrument.

Peak-to-Peak Voltage Measurements (AC)

To make peak-to-peak voltage measurements, use the following procedure:

1. Apply the signal to the Input connector.
2. Set the Coupling switch to AC.

NOTE

For low-frequency signals below about 30 hertz, use the DC position to prevent attenuation of the signal.

3. Set the VOLTS/DIV switch to display about five vertical divisions of the waveform.

4. Set the time-base Triggering controls for a stable display. Set the Time Base to a sweep rate which displays several cycles of the waveform.

5. Turn the 7A15A/7A15AN POSITION control so the lower portion of the waveform coincides with one of the graticule lines below the center horizontal line, and the top of the waveform is within the viewing area. With the time base Position control, move the display so one of the upper peaks lies near the center vertical line (see Fig. 2-1).

6. Measure the divisions of vertical deflection peak to peak. Check that the VARIABLE control is in the CAL position.

NOTE

This technique can also be used to make measurements between two points on the waveform, rather than peak to peak.

7. Multiply the distance measured in step 7 by the VOLTS/DIV switch setting. Include the attenuation factor of the probe if used.

EXAMPLE: Assume that the peak to peak vertical deflection is 4.5 divisions using a 10X attenuator probe, and the VOLTS/DIV switch is set to 1 V.

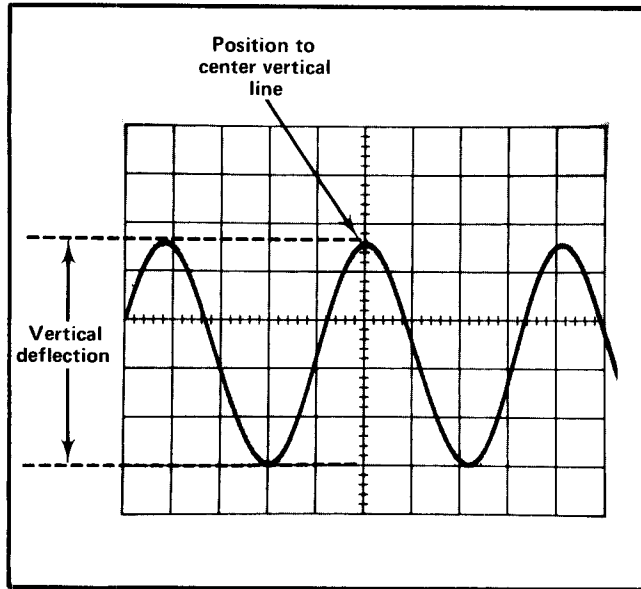

Fig. 2-1. Measuring the Peak-to-Peak voltage of a waveform.

$$\text{Volts} = \text{vertical deflection (divisions)} \times \text{VOLTS/DIV setting} \times \text{probe attenuator factor}$$

Substituting the given values:

$$\text{Volts Peak to Peak} = 4.5 \times 1 \times 10$$

The peak-to-peak voltage is 45 volts.

If you are using a 7A15A with a coded probe and an oscilloscope equipped with readout, simply multiply the distance measured in step 7 by the deflection factor displayed on the CRT.

Instantaneous Voltage Measurements (DC)

To measure the DC level at a given point on a waveform, proceed as follows:

1. Connect the signal to the Input connector.
2. Set the VOLTS/DIV switch to display about five divisions.
3. Set the Coupling switch to GND and position the trace to the bottom graticule line or other reference line. If the voltage is negative with respect to ground, position the trace to the top graticule line. Do not move the POSITION control after this reference line has been established.

NOTE

To measure a voltage level with respect to another voltage rather than ground, make the following changes to Step 3. Set the coupling switch to DC and apply the reference voltage to the Input connector. Then position the trace to the reference line and disconnect the reference voltage.

4. Set the Coupling switch to DC. The ground reference line can be checked at any time by switching to the GND position.

5. Set the time-base Triggering controls for a stable display. Set the Time Base sweep rate for an optimum display of the waveform.

6. Measure the distance in divisions between the reference line and the point on the waveform at which the DC level is to be measured. For example, in Fig. 2-2 the measurement is between the reference line and point A.

7. Establish the polarity of the waveform. With the +UP/INV switch in the +UP position, any point above the reference line is positive.

8. Multiply the distance measured in step 7 by the VOLTS/DIV switch setting. Include the attenuation factor of the probe, if used.

EXAMPLE: Assume the vertical distance measured is 4.6 divisions (see Fig. 2-2) and the waveform is above the reference line using a 10X probe with a VOLTS/DIV switch setting of 0.5 V.

Using the formula:

$$\text{Instantaneous Voltage} = \text{vertical distance (divisions)} \times \text{polarity} \times \text{VOLTS/DIV setting} \times \text{probe attenuation factor}$$

Substituting the given values:

$$\text{Instantaneous Voltage} = 4.6 \times 1 \times 0.5 \text{ V} \times 10$$

The instantaneous voltage is 23 volts.

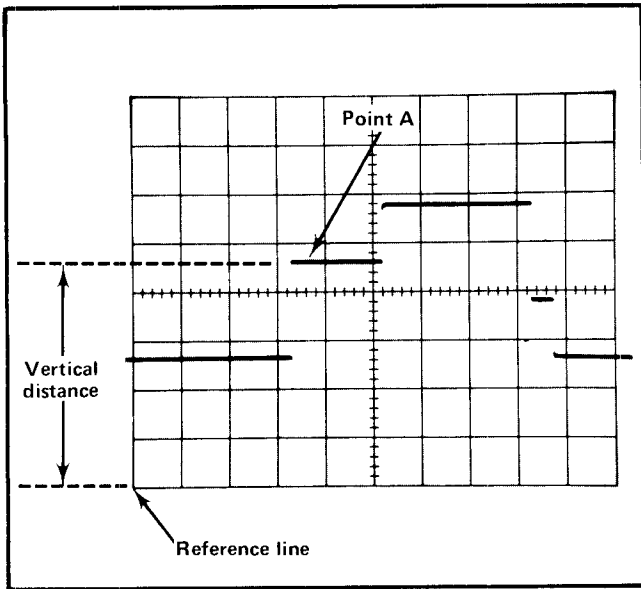

Fig. 2-2 Measuring instantaneous voltage with respect to some reference.

Comparison Measurements

In some applications it may be desirable to establish units of measurement other than those indicated by the VOLTS/DIV switch. This is particularly useful when comparing unknown signals to a reference amplitude. One use for the comparison-measurement technique is to facilitate calibration of equipment where the desired amplitude does not produce an exact number of divisions of deflection. The adjustment will be easier and more accurate if arbitrary units of measurement are established, so that the correct adjustment is indicated by an exact number of divisions of deflection. The following procedure describes how to establish arbitrary units of measure for comparison measurements.

To establish a vertical deflection factor based upon a specific reference amplitude, proceed as follows:

1. Connect the reference signal to the Input connector. Set the time-base sweep rate to display several cycles of the signal.
2. Set the VOLTS/DIV switch and the VARIABLE control to produce a display which is an exact number of vertical divisions in amplitude. Do not change the VARIABLE control after obtaining the desired deflection.
3. To establish an arbitrary vertical deflection factor so the amplitude of an unknown signal can be measured accurately at any setting of the VOLTS/DIV switch, the amplitude of the reference signal must be known. If it is

not known, it can be measured before the VARIABLE control is set in step 2.

4. Divide the amplitude of the reference signal (volts) by the product of the vertical deflection (divisions) established in step 2 and the setting of the VOLTS/DIV switch.

This is the vertical conversion factor.

$$\text{Vertical Conversion Factor} = \frac{\text{reference signal amplitude (volts)}}{\text{vertical deflection (divisions)} \times \text{VOLTS/DIV setting}}$$

5. To measure the amplitude of an unknown signal, disconnect the reference signal and connect the unknown signal to the Input connector. Set the VOLTS/DIV switch to a setting that provides sufficient vertical deflection to make an accurate measurement. Do not re-adjust the VARIABLE control.

6. Measure the vertical deflection in divisions and calculate the amplitude of the unknown signal using the following formula:

$$\text{Signal Amplitude} = \text{VOLTS/DIV setting} \times \text{vertical conversion factor} \times \text{vertical deflection (divisions)}$$

EXAMPLE: Assume a reference signal amplitude of 30 volts, a VOLTS/DIV setting of 5 V and the VARIABLE control adjusted to provide a vertical deflection of four divisions.

Substituting these values in the vertical conversion factor formula (step 4):

$$\text{Vertical Conversion Factor} = \frac{30 \text{ V}}{4 \times 5 \text{ V}} = 1.5$$

Then with a VOLTS/DIV setting of 2 V, the peak to peak amplitude of an unknown signal which produces a vertical deflection of five divisions can be determined by using the signal amplitude formula (step 6):

$$\text{Signal Amplitude} = 2 \text{ V} \times 1.5 \times 5 = 15 \text{ volts}$$

SECTION 3

CIRCUIT DESCRIPTION

Introduction

This section of the manual contains a description of the circuitry used in the 7A15A/7A15AN amplifier. The description begins with a discussion of the instrument using the block diagram shown in the Diagrams section. Then, each circuit is described in detail using block diagrams to show the interconnections between stages in each major circuit and the relationship of the front-panel controls to the individual stages.

Complete schematics of each circuit are given in the Diagrams section. Refer to these schematics throughout the following circuit description for electrical values and relationship.

BLOCK DIAGRAM

The following discussion is provided to aid in understanding the overall concept of the 7A15A/7A15AN before the individual circuits are discussed in detail. Only the basic interconnections between the individual blocks are shown on the block diagram (see Diagrams section). Each block represents a major circuit within the instrument.

The signal to be displayed on the CRT is applied to the Input connector. The signal passes through the input coupling switch, where the appropriate coupling is selected, to the attenuators. The VOLTS/DIV switch selects the correct amount of attenuation and the signal is passed to the Input Amplifier.

The Input Amplifier provides signal polarity inversion in addition to gain setting, variable gain control, and trace positioning. The output of this circuit is applied push-pull to the Signal and Trigger Amplifiers.

The signal and trigger outputs are provided to the oscilloscope via the Interface connector.

The Readout encoding circuit (7A15A only) provides readout logic for the oscilloscope readout system. Logic is supplied identifying the polarity, deflection factor, and the

uncalibrated symbol (when the VARIABLE knob is not fully clockwise). When the IDENTIFY button is pressed, the trace is deflected about 0.3 division and the deflection factor readout is replaced by the word "IDENTIFY" (7A15A only).

DETAILED CIRCUIT DESCRIPTION

Attenuator

General

The Attenuator circuit determines the input coupling and the deflection factor. A diagram of this circuit is shown on Diagram 1 in the Diagrams section.

AC-GND-DC Switch

Input signals connected to the Input connector can be AC-coupled, DC-coupled, or internally disconnected. S100A is a cam-type switch; a contact-closure chart showing the operation is given on Diagram 1. The dots on this chart indicate when the associated contacts are in the position shown (open or closed). When the AC-GND-DC switch is in the DC position, the input signal is coupled directly to the Input Attenuator stage. In the AC position, the input signal passes through capacitor C10. The capacitor prevents the DC component of the signal from passing to the amplifier. The GND position opens the signal path and connects the input circuit of the amplifier to ground. This provides a ground reference without the need to disconnect the applied signal from the Input connector. Resistor R102, connected across the AC-GND-DC switch, allows C10 to be pre-charged in the GND position so the trace remains on screen when switching to the AC position if the applied signal has a high DC level.

Input Attenuator

The effective overall deflection factor of the 7A15A/7A15AN is determined by the setting of the VOLTS/DIV switch, S100B. The basic deflection factor is five millivolts per division of CRT deflection (with Mag switch set to X1). To increase the basic deflection factor to the values indicated on the front panel, precision attenuators are switched into the circuit. S100B is a cam-type switch and the dots on the contact-closure chart (see Diagram 1) indicate when the associated contacts are in the position shown (open or closed). In the 5 mV/Div position, input attenuation is not used; the input signal is connected directly to the input amplifier.

Circuit Description—7A15A/7A15AN

For switch positions above five millivolts, the attenuators are switched into the circuit singly or in pairs to produce the deflection factor indicated on the front panel. These hybrid attenuators are frequency-compensated voltage dividers. For DC and low-frequency signals, the attenuators are primarily resistance dividers and the voltage attenuation is determined by the resistance ratio in the circuit. The reactance of the capacitors in the circuit is so high at low frequencies that their effect is negligible. However, at higher frequencies, the reactance of the capacitors decreases and the attenuator becomes primarily a capacitance divider.

In addition to providing constant attenuation at all frequencies within the bandwidth of the instrument, the input attenuators are designed to maintain the same input RC characteristics (one megohm X 20 pF) for each setting of the VOLTS/DIV switch. Each attenuator contains an adjustable series capacitor to provide correct attenuation at high frequencies, and an adjustable shunt capacitor to provide correct input capacitance.

Input Amplifier

General

The Input Amplifier converts the single-ended signal applied to the Input connector to a differential (push-pull) output. A schematic of this circuit is shown on Diagram 2 in the Diagrams section.

Input Source Follower

The Input Source Follower Q210A provides a high input impedance with a low impedance drive for the following stage. R210 limits the current drive to the gate of Q210A. Dual-diode CR210 provides circuit protection by limiting the voltage swing at the gate of Q210A to about \pm (positive or negative) 15 volts. Q210B provides a constant current source for Q210A. Q210A and Q210B are encapsulated in the same case so that Q210B temperature compensates the circuit.

Amplifier

The signal from the Input Source Follower is applied to paraphase amplifier Q220-Q320. The paraphase amplifier converts the single-ended input to a differential (push-pull) output. It also provides a means of compensating for stray currents throughout the entire amplifier by varying the DC Level at the base of Q320 via the DC Bal control R322. The differential signal from the paraphase amplifier is cascaded to the Inverting Amplifier, a set of common base differential amplifiers Q230-Q330 and Q235-Q335. With the POLARITY switch set to +UP, Q230 and Q330 are forward biased while Q235 and Q335 are reverse biased. The signal is therefore allowed to pass un-inverted through Q230-Q330. By setting the POLARITY switch to INVERT,

Q230 and Q330 are reverse biased and Q235 and Q335 are forward biased. The signal is inverted through Q235-Q335. Current gain for amplifiers Q230-Q330 and Q235-Q335 is controlled by the GAIN potentiometer R238 and VARIABLE control R239. The output from Q230-Q330 or Q235-Q335 (depending on the POLARITY switch) is connected to the X1 amplifier, Q240-Q340, and the X10 amplifier, Q245-Q345. The MAG switch determines which amplifier (X1 or X10) is on, by switching their emitter supply voltages. Current gain for the X10 amplifier is adjusted by R245. R341 and C341 provide frequency compensation for the X1 amplifier. The signal from the X1 or X10 amplifier (depending on the MAG switch) is cascaded through the common base amplifier, Q250-Q350, to the Signal Amplifier, Q260-Q360, and Trigger Amplifier, Q270-Q370.

Connectors and Readout

General

The Connectors and Readout circuit consists of the power supply and signal distribution from the Interface Connector and the Readout Encoding circuit. A schematic of this circuit is shown on Diagram 3 in the Diagrams section.

Connectors

All the connections made to the mainframe by the 7A15A/7A15AN are shown on the Connectors portion of Diagram 1. Also shown are the power supply decoupling components.

Readout Encoding (7A15A only)

The Readout Encoding circuit consists of switching resistors and probe sensing stage Q620. This circuit encodes the Row and Column output lines for readout of deflection factor, uncalibrated deflection factor (VARIABLE) information, and signal inversion. Data is encoded on these output lines by switching resistors between them and the time-slot input lines or by current added through Q620.

R647-C647 are switched between time-slot three (TS-3) and the Column output line when the CAL switch is in the uncal position. This results in the symbol > (greater than) being displayed preceding the deflection factor readout. R648 is switched between TS-2 and the Column output line when the POLARITY switch is in the INVERT position. This results in the symbol ∇ (inverted) being displayed preceding the deflection factor readout.

Switching resistors are used to indicate the setting of the VOLTS/DIV switch to the mainframe readout system. The dots on the contact-closure chart (see Diagram 3) indicate when the associated contacts on the VOLTS/DIV cam

switch are closed. R633, R634, and R635 select the number 1, 2, or 5 depending on the combination that is switched in. R637 selects the m (milli-) prefix and R639 selects the symbol V (volts) in the 5 mV through .5 V (500 mV) positions of the VOLTS/DIV switch. R638 selects the symbol V in the 1, 2, and 5 V positions. R630, R631, and the output of the probe sensing stage (Q620) select the decimal point (number of zeroes), again depending on the resistor combination switched in by the VOLTS/DIV switch.

Probe sensing stage Q620 identifies the attenuation factor of the probe connected to the Input connector by sensing the amount of current flowing through the probe coding resistor located in the probe connector. The output of this circuit corrects the mainframe readout system to include the probe attenuation factor. The third contact of the Input connector provides the input to the probe sensing device from the probe coding resistance (coded probes only; see Operating Instructions). The third contact is also used for the IDENTIFY input. The coding resistor forms a voltage divider with R621 through CR621 to the -15 V supply. The resultant voltage sets the bias on Q620 and determines the collector current, along with emitter resistor R622. When the -15 volt time-slot pulse is applied to Interface Connector B33, Q620 is interrogated and its collector current is added to the column current output through Interface Connector A37.

With a 1X probe (or no probe) connected to the Input connector, Q620 is turned off. The deflection factor readout is determined by the VOLTS/DIV switch position. With a 10X probe connected, the bias on Q620 allows 100 microamperes of collector current to flow. This increases the deflection factor readout by a factor of 10.

The IDENTIFY button (S45 on Diagram 1) does two things when pressed:

1. It causes the trace representing the appropriate channel of the 7A15A to move.
2. Forward biases CR621 and Q620 to result in a sufficient amount of collector current which, when added to the column current output replaces the deflection factor readout with the word "IDENTIFY".

These two actions aid in identifying the 7A15A trace when multiple traces are displayed. When the IDENTIFY button is released, the deflection factor readout is restored.

For further information on the operation of the readout system, see the oscilloscope instruction manual.

SECTION 4

MAINTENANCE

Introduction

This section of the manual contains maintenance information for use in preventive maintenance, corrective maintenance, and troubleshooting of the 7A15A/7A15AN.

Further maintenance information relating to general maintenance can be found in the instruction manuals for the 7000-series oscilloscopes.

PREVENTIVE MAINTENANCE

General

Preventive maintenance, consisting of cleaning, visual inspection, etc., performed on a regular basis, will improve the reliability of this instrument. Periodic checks of the semiconductor devices used in the unit are not recommended as a preventive maintenance measure. See semiconductor-checking information given under Troubleshooting.

Cleaning

CAUTION

Avoid the use of chemical cleaning agents which might damage the plastics used in this instrument. Special care should be taken when cleaning the Polyphenylene Oxide attenuator board. Do not apply any solvent containing ketones, esters or halogenated hydrocarbons. To clean, use only water soluble detergents, ethyl, methyl or isopropyl alcohol.

Front Panel. Loose dust may be removed with a soft cloth or a dry brush. Water and mild detergent may be used; however, abrasive cleaners should not be used.

Interior. Cleaning the interior of the unit should precede calibration, since the cleaning process could alter the settings of the calibration adjustments. Use low-velocity compressed air to blow off the accumulated dust. Hardened dirt can be removed with a soft, dry brush, cotton-tipped swab, or cloth dampened with a mild detergent and water solution.

Lubrication

Use a cleaning-type lubricant on shaft bushings, interconnecting plug contacts, and switch contacts. Lubricate switch detents with a heavier grease. A lubrication kit containing the necessary lubricating materials and instructions is available through any Tektronix Field Office. Order Tektronix Part Number 003-0342-01.

TROUBLESHOOTING

General

The following is provided to augment information contained in other sections of this manual when troubleshooting the 7A15A/7A15AN. The schematic diagrams, circuit description, and calibration sections should be used to full advantage. The circuit description section gives detailed information on circuit behavior and output requirements.

Troubleshooting Aids

Diagrams. Circuit diagrams are given on foldout pages in Section 7. The circuit number and electrical value of each component in this instrument are shown on the diagrams. Important voltages are also shown.

Circuit Boards. The circuit boards used in the 7A15A/7A15AN are outlined on the schematic diagrams, and photographs of the boards are shown on the backs of the schematic diagrams. Each board-mounted electrical component is identified on the photograph by its circuit number.

Component and Wiring Color Code. Colored stripes or dots on resistors and capacitors signify electrical values, tolerances, etc., according to the EIA standard color code. Components not color coded usually have the value printed on the body.

The insulated wires used for interconnection in the 7A15A/7A15AN, are color coded to facilitate tracing wires from one point to another in the unit.

Semiconductor Lead Configuration. Fig. 4-1 shows the lead configurations of the semiconductor devices used in this instrument.

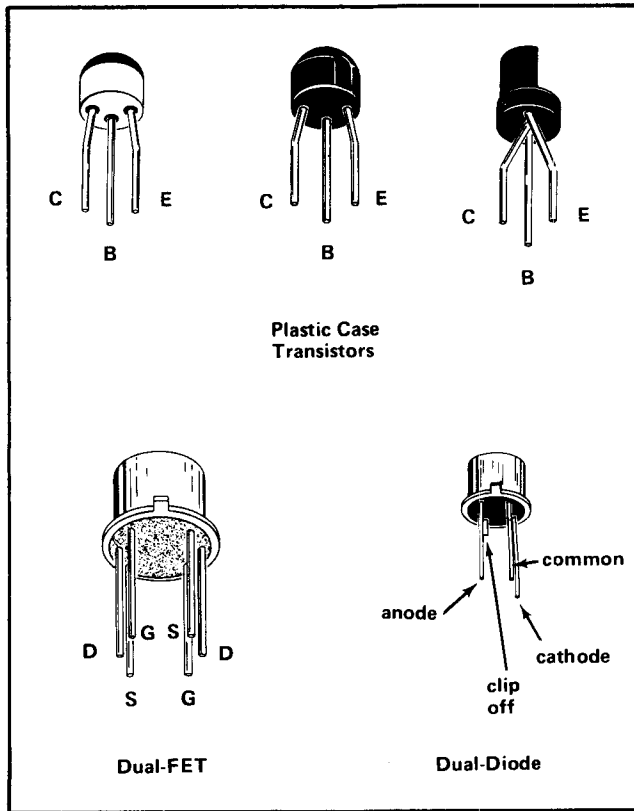

Fig. 4-1. Electrode configuration for semiconductors in the 7A15A/7A15AN.

Troubleshooting Equipment

The following equipment is useful for troubleshooting the 7A15A/7A15AN.

1. **Semiconductor Tester**—Some means of testing the transistors, diodes, and FET's used in this instrument is helpful. A transistor-curve tracer such as the Tektronix Type 576 will give the most complete information.

2. **DC Voltmeter and Ohmmeter**—A voltmeter is required for checking voltages within the circuits, and an ohmmeter for checking resistors and diodes.

3. **Test Oscilloscope**—A test oscilloscope is required to view waveforms at different points in the circuit. A Tektronix 7000-series Oscilloscope equipped with a readout system, 7D13 Digital Multimeter unit, 7B-series Time-Base unit, and a 7A-series Amplifier unit with a 10X probe will meet the needs of both items 2 and 3.

4. **Plug-in Extender**—A fixture that permits operation of the unit outside of the plug-in compartment for better accessibility during troubleshooting. Order Tektronix part number 067-0589-00.

Troubleshooting Procedure

This troubleshooting procedure is arranged in an order which checks the simple trouble possibilities before proceeding with extensive troubleshooting.

1. **Check Control Settings.** An incorrect setting of the 7A15A/7A15AN controls can indicate a trouble that does not exist. If there is any question about the correct function or operation of a control or front-panel connector, see the Operating Instructions section.

2. **Check Associated Equipment.** Before proceeding with troubleshooting of the 7A15A/7A15AN, check that the equipment used with this instrument is operating correctly. If possible, substitute an amplifier unit known to be operating correctly into the indicator unit and see if the problem persists. Check that the input signals are properly connected and that the interconnecting cables are not defective.

3. **Visual Check.** Visually check the portion of the instrument in which the trouble is suspected. Many troubles can be located by visual indications, such as unsoldered connections, broken wires, damaged circuit boards, damaged components, etc.

4. **Check Instrument Performance.** Check the calibration of the unit or the affected circuit, by performing Performance Check of Section 5. The apparent trouble may only be a result of mis-adjustment, and may be corrected by calibration. Complete calibration instructions are given in Part II of Section 5.

5. **Check Voltages.** Often the defective component or stage can be located by checking for the correct voltage in the circuit. Typical voltages are given on the diagrams; however, these are not absolute and may vary slightly between instruments. To obtain operating conditions similar to those used to take these readings, see the instructions in the Diagrams section.

6. **Check Individual Components.** The following methods are provided for checking the individual components in the 7A15A/7A15AN. Components which are soldered in place are best checked by disconnecting one end to isolate the measurement from the effects of surrounding circuitry.

NOTE

To locate intermittent or temperature sensitive components mounted on the attenuator board, Quik Freeze (Miller Stephenson, MS-240, Tektronix Part Number 006-0173-01) is recommended. Dry ice or dichlorodi-fluorremethane (Freon 12, Dupont or Can-O-Gas) may also be used. Other types of circuit coolant may damage the polyphenylene oxide boards.

A. **TRANSISTORS.** The best check of transistor operation is actual performance under operating conditions. If a transistor is suspected of being defective, it can best be checked by substituting a component known to be good; however, be sure that circuit conditions are not such that a replacement might also be damaged. If substitute transistors are not available, use a dynamic tester (such as Tektronix Type 576). Static-type testers may be used, but since they do not check operation under simulated operating conditions, some defects may go unnoticed. Fig. 4-1 shows base pin and socket arrangements of semiconductor devices. Be sure the power is off before attempting to remove or replace any transistor.

B. **DIODES.** A diode can be checked for an open or for a short circuit by measuring the resistance between terminals with an ohmmeter set to the R X 1k scale. The diode resistance should be very high in one direction and very low when the meter leads are reversed. Do not check tunnel diodes or back diodes with an ohmmeter.

CAUTION

Do not use an ohmmeter scale that has a high internal current. High currents may damage the diodes.

C. **RESISTORS.** Check resistors with an ohmmeter. Resistor tolerance is given in the Electrical Parts List. Resistors normally do not need to be replaced unless the measured value varies widely from the specified value.

D. **CAPACITORS.** A leaky or shorted capacitor can be detected by checking resistance with an ohmmeter on the highest scale. Use an ohmmeter which will not exceed the voltage rating of the capacitor. The resistance reading should be high after initial charge of the capacitor. An open capacitor can best be detected with a capacitance meter, or by checking whether the capacitor passes AC signals.

7. Repair and Readjust the Circuit. Special techniques required to replace components in this unit are given under Component Replacement. Be sure to check the performance of any circuit that has been repaired or that has had any electrical components replaced. Recalibration of the affected circuit may be necessary.

CORRECTIVE MAINTENANCE

General

Corrective maintenance consists of component replacement and instrument repair. Special techniques required to replace components in this instrument are given here.

Obtaining Replacement Parts

Standard Parts. All electrical and mechanical part replacements for the 7A15A/7A15AN can be obtained through your local Tektronix Field Office or representative. However, many of the electronic components can be obtained locally in less time than is required to order them from Tektronix, Inc. Before purchasing or ordering replacement parts, check the parts list for value, tolerance, rating and description.

NOTE

When selecting replacement parts, it is important to remember that the physical size and shape of a component may affect the performance of the instrument, particularly at high frequencies. All replacement parts should be direct replacements unless it is known that a different component will not adversely affect instrument performance.

Special Parts. In addition to the standard electronic components, some special parts are used in the 7A15A/7A15AN. These parts are manufactured or selected by Tektronix, Inc. in accordance with our specifications. These special parts are indicated in the parts list by an asterisk preceding the part number. Most of the mechanical parts used in this instrument have been manufactured by Tektronix, Inc. Order all special parts directly from your local Tektronix Field Office or representative.

Ordering Parts. When ordering replacement parts from Tektronix, Inc., include the following information:

1. Instrument Type.
2. Instrument Serial Number.
3. A description of the part (if electrical, include circuit number).
4. Tektronix Part Number.

Soldering Techniques

WARNING

Disconnect the instrument from the power source before soldering.

Attenuator Circuit Board. The Attenuator circuit board is made from polyphenylene oxide because of its excellent electrical characteristics. Use more than normal care when cleaning or soldering this material. The following rules should be observed when removing or replacing parts:

Maintenance—7A15A/7A15AN

1. Use a low-wattage soldering iron (not over 15 watts).
2. Do not apply more heat, or apply heat for a longer time, than is absolutely necessary.
3. Use some form of vacuum solder remover when removing multi-lead devices.
4. Do not apply any solvent containing ketones, esters of halogenated hydrocarbons.
5. To clean, use only water-soluble detergents, ethyl, methyl or isopropyl alcohol.

Circuit Boards (except Attenuator board). The components mounted on the circuit boards in the amplifier can be replaced using normal circuit board soldering techniques. Keep the following points in mind when soldering on the circuit boards:

1. Use a pencil-type soldering iron with a (wattage) rating from 15 to 50 watts.
2. Apply heat from the soldering iron to the junction between the component and the circuit board.
3. Heat-shunt the lead to the component by means of a pair of long-nose pliers.
4. Avoid excessive heating of the junction with the circuit board, as this could separate the circuit board wiring from the base material.
5. Use electronic grade 60-40 tin lead solder.
6. Clip off any excess lead length extending beyond the circuit board. Clean off any residual flux with a flux-removing solvent.

Metal Terminals. When soldering metal terminals (potentiometers, etc.) use 60-40 tin-lead solder and a 15 to 50 watt soldering iron. Observe the following precautions when soldering metal terminals:

1. Apply only enough heat to make the solder flow freely.
2. Apply only enough solder to form a solid connection. Excess solder may impair the function of the part.

3. If a wire extends beyond the solder joint, clip off the excess.

4. Clean the flux from the solder joint with a flux-removing solvent.

Component Replacement

WARNING

Disconnect the equipment from the power source before replacing components.

Semiconductor Replacement. Transistors should not be replaced unless actually defective. If removed from their sockets during routine maintenance, return them to their original sockets. Unnecessary replacement of transistors may effect the calibration of this instrument. When transistors are replaced, check the performance of the part of the instrument which may be affected.

Replacement semiconductors should be of the original type or a direct replacement. Fig. 4-1 shows the lead configurations of the semiconductors used in this instrument. If the replacement semiconductor is not of the original type, check the manufacturer's basing diagram for proper basing.

Circuit Board Removal

In general, the circuit boards used in the 7A15A/7A15AN need never be removed unless they must be replaced. Electrical connections to the boards are made by soldered connections. If it is necessary to replace a circuit board assembly, use the following procedures.

A. READOUT CIRCUIT BOARD REMOVAL (7A15A Only)

1. Disconnect the wires connected to the outside of the board.
2. Remove the seven screws holding the board to the mounting surface.
3. Disconnect the wires connected to the inside of the board.
4. Remove the board from the unit.
5. To replace the board, reverse the order of removal.

B. ATTENUATOR CIRCUIT BOARD REMOVAL

1. Remove the readout board as outlined in the previous procedure.
2. Disconnect the resistor and capacitor connected to the rear of the board.
3. Loosen the front set screw on the VARIABLE control shaft coupling (use a 0.050-inch hex-key wrench).
4. Remove the red VARIABLE control knob and glass rod from the control shaft.
5. Remove the remaining front-panel knobs using a 1/16-inch hex-key wrench.
6. Remove the front panel from the instrument.
7. Remove the attenuator shields.
8. Disconnect the wires and resistor from the input BNC connector.
9. Remove the input BNC connector.
10. Remove the attenuator board with cam switch from the instrument.
11. Replace by reversing the Removal Procedures.

C. AMPLIFIER CIRCUIT BOARD REMOVAL

1. Remove the plastic plug-in guide from the rear of the instrument.
2. Disconnect the wires connected to the board from the front-panel controls.

3. Loosen the hex-socket screw in the coupling of the VARIABLE control shaft using a 0.050-inch hex-key wrench. Pull the VARIABLE knob and glass shaft from the front of the instrument.

4. Disconnect the resistor-capacitor combinations connected to the ceramic strip at the front of the board.

5. Remove the screws and nuts securing the board to the chassis or other mounting surface.

6. Remove the board from the instrument.

7. To replace, reverse the order of removal.

Switch Replacement

Several types of switches are used in the 7A15A/7A15AN. The slide and micro switches should be replaced as a unit if damaged. The following special maintenance information is provided for the cam-type switches.

A. CAM-TYPE SWITCHES

CAUTION

Repair of cam-type switches should be undertaken only by experienced maintenance personnel. Switch alignment and spring tension of the contacts must be carefully maintained for proper operation of the switch. For assistance in maintenance of the cam-type switches, contact your local Tektronix Field Office or representative.

Recalibration After Repair

After any electrical component has been replaced, the calibration of that particular circuit should be checked, as well as the calibration of other closely related circuits. Refer to Section 5 for these procedures.

SECTION 5

CALIBRATION

Introduction

To assure instrument accuracy, check the calibration of the 7A15A/7A15AN every 1000 hours of operation or every six months if used infrequently. Before complete calibration, thoroughly clean and inspect this instrument as outlined in the Maintenance section.

Tektronix Field Service

Tektronix, Inc., provides complete instrument repair and recalibration service at local Field Service Centers and the Factory Service Center. Contact your local Field Office or representative for further information.

Using This Procedure

General. This section provides several features to facilitate checking or adjusting the 7A15A/7A15AN. These are:

Short Form Procedure. As an aid to the calibration of this instrument, a short form procedure is given prior to the complete procedure. To facilitate instrument calibration for the experienced calibrator, the short form procedure lists the calibration adjustments necessary for each step and the applicable tolerances.

Partial Calibration Procedure. A partial calibration is often desirable after replacing components, or to touch up the adjustment of a portion of the instrument between major recalibrations. To calibrate only part of the instrument, set the controls as given under Preliminary Control Settings and start with the nearest numbered step preceding the desired portion. To prevent unnecessary recalibration of other parts of the instrument, readjust only if the tolerance given in the CHECK— part of the step is not met.

Complete Calibration Procedure. Completion of each step in the Calibration Procedure insures that this instrument meets the electrical specifications given in Section 1. Where possible, instrument performance is checked before an adjustment is made. For best overall instrument performance when performing a complete calibration procedure, make each adjustment to the exact setting even if the CHECK— is within the allowable tolerance.

TEST EQUIPMENT REQUIRED

General

The following test equipment and accessories, or its equivalent is required for complete calibration of the 7A15A/7A15AN. Specifications given for the test equipment are the minimum necessary for accurate calibration. Therefore, some of the specifications listed here may be somewhat less precise than the actual performance capabilities of the test equipment. All test equipment is assumed to be correctly calibrated and operating within the listed specifications of the recommended equipment.

Test Equipment

1. Calibration Oscilloscope. Tektronix 7704 or equivalent 7000-series Oscilloscope.

2. 7B-Series Time Base plug-in unit.

3¹. Standard Amplitude Calibrator. Amplitude accuracy, within 0.25%; signal amplitude, 5 millivolts to 50 volts; frequency, 1 kHz. Tektronix Calibration Fixture 067-0502-01 recommended.

4². Square-wave Generator. Must have the following output capabilities: 12 volts amplitude into 50 ohms at one kilohertz with a rise time of 12 nanoseconds or less; 500 millivolts into 50 ohms at 100 kilohertz with a risetime of one nanosecond or less. Tektronix Type 106 Square-Wave Generator recommended.

Accessories

5. Cable. Impedance, 50 ohms; connector, BNC; length, 42 inches. Tektronix Part Number 011-0060-01.

6². Five nanosecond GR cable. Tektronix Part Number 017-0512-00.

¹ Needed for Gain Calibration only.

² Needed for Compensation adjustments only.

Calibration—7A15A/7A15AN

7². Termination, thru-line. Impedance, 50 ohms; connectors, GR to BNC male. Tektronix Part Number 017-0083-00.

8². Adapter, connectors, GR to BNC male. Tektronix Part Number 017-0064-00.

9². 10X Attenuator. Impedance, 50 ohms; accuracy, $\pm 2\%$; connectors, GR. Tektronix Part Number 017-0078-00.

10². RC Normalizer. Time constant, 1 megohm X 20 picofarad; attenuation 2X; connectors BNC. Tektronix Part Number 067-0538-00.

Adjustment Tools

11. Low-capacitance screwdriver. 1 1/2-inch shaft. Tektronix Part Number 003-0000-00.

12². Tuning Tool. Handle with inserts for input capacitance and attenuator adjustments. Tektronix Part Numbers 003-0307-00, 003-0334-00, and 003-0497-00.

PERFORMANCE CHECK PROCEDURE

1. Gain Calibration

a. Set GAIN adjustment for a 5 division vertical deflection with 50 mV of applied signal to the input, with VOLTS/DIV switch set to 10 mV.

b. CHECK—That the VARIABLE control will reduce the vertical deflection by a factor of at least 2.5:1.

c. CHECK—X10 Gain for a vertical deflection within 10% of applied signal with VOLTS/DIV switch set to 10 mV.

d. CHECK—That the vertical deflection is accurate to within 2% at all VOLTS/DIV switch settings.

2. DC Balance

a. CHECK—DC Bal for a VARIABLE trace shift of not more than 0.5 division.

b. CHECK—X10 DC Bal for a minimum MAG trace shift.

3. Compensation

a. CHECK—Input capacitance (C100) for optimum square-wave response.

b. CHECK—Attenuator compensation for flat top and square corner within 0.15 division at all VOLTS/DIV switch settings.

c. CHECK—High-frequency compensation for optimum square-wave response with aberrations not to exceed 5% peak to peak.

CALIBRATION PROCEDURE

General

The following procedure is arranged so that the 7A15A/7A15AN can be calibrated with the least interaction of adjustments and re-connection of equipment. The control settings and test equipment setup throughout this procedure continue from the preceding step(s) unless otherwise noted. Refer to Fig. 5-1 for location of adjustments.

NOTE

Control titles which are printed on the front panel of the 7A15A/7A15AN are capitalized in this procedure (e.g., POSITION). Internal adjustments and associated equipment controls are initially capitalized only (e.g., oscilloscope Vertical Mode).

Preliminary Procedure for Calibration

1. Remove the oscilloscope left side cover and side panel of plug-in.

2. Insert the 7A15A/7A15AN in the calibration oscilloscope left vertical compartment.

3. Insert the time base in the calibration oscilloscope A Horizontal compartment.

4. Connect the oscilloscope to a suitable power source.

5. Turn the oscilloscope on and allow 20 minutes warm-up before proceeding.

NOTE

This instrument should be calibrated at an ambient temperature of $+20^{\circ}\text{C}$ to $+30^{\circ}\text{C}$ for best overall accuracy. The performance of the instrument can be checked at any temperature within the 0°C to $+50^{\circ}\text{C}$ range.

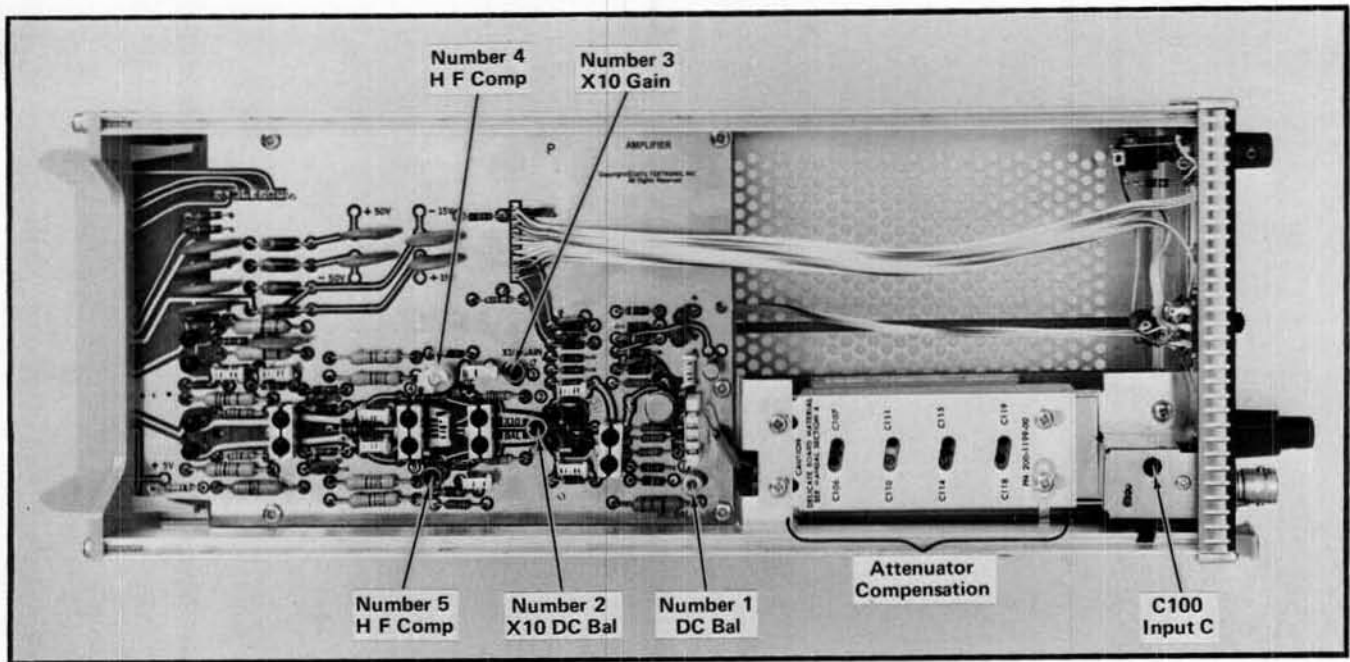

Fig. 5-1. Location of adjustments for 7A15A/7A15AN. (7A15A shown)

Preliminary Control Settings

Set the calibration oscilloscope and 7A15A/7A15AN as follows:

Calibration Oscilloscope

Intensity	Midrange
Focus	Adjust well-defined display
Readout	Midrange (if so equipped)
Control Illum	As desired
Grat Illum	As desired
Vertical Mode	Left
Trigger Source	Left Vert

7A15A/7A15AN

POSITION	Midrange
POLARITY	+UP
MAG	X1
VOLTS/DIV	10 mV
AC-GND-DC	DC
VARIABLE	CAL (full clockwise)

1. Check/Adjust GAIN

a. Connect the Standard Amplitude Calibrator output to the Input connector with a 42-inch BNC cable.

b. Set the Standard Amplitude Calibrator for a 50-millivolt square-wave output.

c. CHECK—CRT display for a vertical deflection of five-divisions ± 0.1 division.

d. ADJUST—Front panel GAIN control for exactly five-divisions vertical deflection.

CHECK VARIABLE GAIN RANGE

e. Rotate VARIABLE control fully counterclockwise.

f. CHECK—That the vertical deflection is equal to or less than two-divisions. Return VARIABLE control to the CAL position.

CHECK/ADJUST X10 GAIN

g. Set the Standard Amplitude Calibrator for a 5-millivolt square-wave output. Set MAG to X10.

h. CHECK—CRT display for a vertical deflection of five-divisions ± 0.5 division.

i. ADJUST—the X10 Gain adjustment (number 3) for exactly five vertical divisions. Return MAG to X1.

CHECK DEFLECTION FACTOR ACCURACY

j. CHECK—Using the VOLTS/DIV switch and Standard Amplitude Calibrator settings given in Table 5-1, check

Calibration—7A15A/7A15AN

vertical deflection is within 2% for each position of the VOLTS/DIV switch.

k. Disconnect all test equipment and return the VOLTS/DIV switch to 10 mV.

TABLE 5-1

Vertical Deflection Accuracy

VOLTS/DIV Switch Setting	Standard Amplitude Calibrator Output	Vertical Deflection in Divisions	Maximum Error for $\pm 2\%$ Accuracy (divisions)
5 mV	20 mV	4	± 0.08
10 mV	50 mV	5	± 0.1
20 mV	0.1 V	5	± 0.1
50 mV	0.2 V	4	± 0.08
.1 V	0.5 V	5	± 0.1
.2 V	1 V	5	± 0.1
.5 V	2 V	4	± 0.08
1 V	5 V	5	± 0.1
2 V	10 V	5	± 0.1
5 V	20 V	4	± 0.08

2. Check/Adjust DC Bal

a. Set AC-GND-DC switch to GND.

b. CHECK—While rotating the VARIABLE control throughout its ranges check that the displayed trace does not move more than 0.5 divisions vertically.

c. ADJUST—DC Bal adjustment (number 1) for minimum vertical trace shift while rotating the VARIABLE control throughout its range.

ADJUST X10 DC BAL

d. ADJUST—Center the display and adjust X10 Bal (number 2) for a minimum vertical trace shift while switching the MAG switch between X1 and X10.

e. Return the MAG switch to its X1 position.

f. Recheck X10 Gain (step 1).

3. Adjust Input Capacitance

a. Set VOLTS/DIV switch to 5 mV and AC-GND-DC switch to DC.

b. Connect the square-wave generator high amplitude (12 nanosecond) output to the Input connector with a five-nanosecond GR cable, 10X GR attenuator, thru-line GR termination and 20 pF normalizer.

c. Set the square-wave generator for a six-division display of a one-kilohertz signal.

d. Set the time-base unit for a triggered display at a sweep rate of 0.2 millisecond/division.

e. ADJUST—C100 for optimum square corner on the displayed waveform.

ADJUST ATTENUATOR COMPENSATION

f. Set the VOLTS/DIV switch to 10 mV.

g. Set square-wave generator for a six-division display of one-kilohertz signal.

h. ADJUST—attenuator compensations as given in Table 5-2 for optimum square corner and flat top (within 0.15 divisions) on the displayed waveform (use tuning tool).

TABLE 5-2

Attenuator Compensation

VOLTS/DIV Switch Setting	Adjust for Optimum	
	Square Corner	Flat Top
10 mV	C106	C107
20 mV	C110	C111
50 mV	C114	C115
0.1 V	Check	Check

Remove 10X GR attenuator.

0.2 V	Check	Check
0.5 V	C118	C119
1 V	Check	Check

Replace thru-line 50-ohm GR termination with GR to BNC male adapter

2 V	Check	Check
5 V	Check	Check
10 V	Check	Check

CHECK/ADJUST HIGH-FREQUENCY COMPENSATION

i. Set VOLTS/DIV switch to 10 mV.

j. Connect the square-wave generator fast-rise (1 nanosecond) output to the Input connector with the five-nanosecond GR cable, 10X GR attenuator, and thru-line 50-ohm GR attenuator.

k. Set square-wave generator for a six-division display (60 millivolts) of a 100 kilohertz signal.

i. Set time-base unit for a triggered display at a sweep rate of 0.2 microseconds/division.

NOTE

In the following steps, change the time-base unit magnifier from X1 to X10 and compare the response at both sweep rates.

m. CHECK—CRT display for optimum square-wave response with aberrations not to exceed 0.24 divisions peak to peak.

n. ADJUST—adjustments numbers 4 and 5 for optimum square-wave response with aberrations. Use low-capacitance screwdriver to adjust the variable capacitor. Repeat these adjustments until optimum response is obtained.

This completes the calibration of the 7A15A/7A15AN. Disconnect all test equipment.

PARTS LIST ABBREVIATIONS

BHB	binding head brass	int	internal
BHS	binding head steel	lg	length or long
cap.	capacitor	met.	metal
cer	ceramic	mtg hdw	mounting hardware
comp	composition	OD	outside diameter
conn	connector	OHB	oval head brass
CRT	cathode-ray tube	OHS	oval head steel
csk	countersunk	P/O	part of
DE	double end	PHB	pan head brass
dia	diameter	PHS	pan head steel
div	division	plstc	plastic
elect.	electrolytic	PMC	paper, metal cased
EMC	electrolytic, metal cased	poly	polystyrene
EMT	electrolytic, metal tubular	prec	precision
ext	external	PT	paper, tubular
F & I	focus and intensity	PTM	paper or plastic, tubular, molded
FHB	flat head brass	RHB	round head brass
FHS	flat head steel	RHS	round head steel
Fil HB	fillister head brass	SE	single end
Fil HS	fillister head steel	SN or S/N	serial number
h	height or high	S or SW	switch
hex.	hexagonal	TC	temperature compensated
HHB	hex head brass	THB	truss head brass
HHS	hex head steel	thk	thick
HSB	hex socket brass	THS	truss head steel
HSS	hex socket steel	tub.	tubular
ID	inside diameter	var	variable
inc	incandescent	w	wide or width
		WW	wire-wound

PARTS ORDERING INFORMATION

Replacement parts are available from or through your local Tektronix, Inc. Field Office or representative.

Changes to Tektronix instruments are sometimes made to accommodate improved components as they become available, and to give you the benefit of the latest circuit improvements developed in our engineering department. It is therefore important, when ordering parts, to include the following information in your order: Part number, instrument type or number, serial or model number, and modification number if applicable.

If a part you have ordered has been replaced with a new or improved part, your local Tektronix, Inc. Field Office or representative will contact you concerning any change in part number.

SPECIAL NOTES AND SYMBOLS

- | | |
|-----------------|---|
| ×000 | Part first added at this serial number |
| 00× | Part removed after this serial number |
| *000-0000-00 | Asterisk preceding Tektronix Part Number indicates manufactured by or for Tektronix, Inc., or reworked or checked components. |
| Use 000-0000-00 | Part number indicated is direct replacement. |

REPLACEABLE ELECTRICAL PARTS

PARTS ORDERING INFORMATION

Replacement parts are available from or through your local Tektronix, Inc. Field Office or representative.

Changes to Tektronix instruments are sometimes made to accommodate improved components as they become available, and to give you the benefit of the latest circuit improvements developed in our engineering department. It is therefore important, when ordering parts, to include the following information in your order: Part number, instrument type or number, serial number, and modification number if applicable.

If a part you have ordered has been replaced with a new or improved part, your local Tektronix, Inc. Field Office or representative will contact you concerning any change in part number.

Change information, if any, is located at the rear of this manual.

SPECIAL NOTES AND SYMBOLS

X000 Part first added at this serial number
00X Part removed after this serial number

ITEM NAME

In the Parts List, an Item Name is separated from the description by a colon (:). Because of space limitations, an Item Name may sometimes appear as incomplete. For further Item Name identification, the U.S. Federal Cataloging Handbook H6-1 can be utilized where possible.

ABBREVIATIONS

ACTR	ACTUATOR	PLSTC	PLASTIC
ASSY	ASSEMBLY	QTZ	QUARTZ
CAP	CAPACITOR	RECP	RECEPTACLE
CER	CERAMIC	RES	RESISTOR
CKT	CIRCUIT	RF	RADIO FREQUENCY
COMP	COMPOSITION	SEL	SELECTED
CONN	CONNECTOR	SEMICOND	SEMICONDUCTOR
ELCTLT	ELECTROLYTIC	SENS	SENSITIVE
ELEC	ELECTRICAL	VAR	VARIABLE
INCAND	INCANDESCENT	WW	WIREWOUND
LED	LIGHT EMITTING DIODE	XFMR	TRANSFORMER
NONWIR	NON WIREWOUND	XTAL	CRYSTAL

CROSS INDEX—MFR. CODE NUMBER TO MANUFACTURER

Mfr. Code	Manufacturer	Address	City, State, Zip
01121	ALLEN-BRADLEY COMPANY	1201 2ND STREET SOUTH	MILWAUKEE, WI 53204
04222	AVX CERAMICS, DIVISION OF AVX CORP.	P O BOX 867, 19TH AVE. SOUTH	MURTL BEACH, SC 29577
07263	FAIRCHILD SEMICONDUCTOR, A DIV. OF FAIRCHILD CAMERA AND INSTRUMENT CORP.	464 ELLIS STREET	MOUNTAIN VIEW, CA 94042
07910	TELEDYNE SEMICONDUCTOR	12515 CHADRON AVE.	HAWTHORNE, CA 90250
12697	CLAROSTAT MFG. CO., INC.	LOWER WASHINGTON STREET	DOVER, NH 03820
24931	SPECIALTY CONNECTOR CO., INC.	3560 MADISON AVE.	INDIANAPOLIS, IN 46227
56289	SPRAGUE ELECTRIC CO.	644 W. 12TH ST.	NORTH ADAMS, MA 01247
72982	ERIE TECHNOLOGICAL PRODUCTS, INC.	2500 HARBOR BLVD.	ERIE, PA 16512
73138	BECKMAN INSTRUMENTS, INC., HELIPOT DIV.	299 10TH AVE. S. W.	FULLERTON, CA 92634
74970	JOHNSON, E. F., CO.	401 N. BROAD ST.	WASECA, MN 56093
75042	TRW ELECTRONIC COMPONENTS, IRC FIXED RESISTORS, PHILADELPHIA DIVISION	SHERMAN AVE.	PHILADELPHIA, PA 19108
77820	BENDIX CORP., THE, ELECTRICAL COMPONENTS DIVISION	550 DAVISVILLE RD., P O BOX 96	SIDNEY, NY 13838
78488	STACKPOLE CARBON CO.	P O BOX 500	ST. MARYS, PA 15857
79727	C-W INDUSTRIES	2500 HARBOR BLVD.	WARMINISTER, PA 18974
80009	TEKTRONIX, INC.	P. O. BOX 609	BEAVERTON, OR 97077
80740	BECKMAN INSTRUMENTS, INC.		FULLERTON, CA 92634
91637	DALE ELECTRONICS, INC.		COLUMBUS, NE 68601

Ckt No.	Tektronix Part No.	Serial/Model No. Eff	Dscont	Name & Description	Mfr Code	Mfr Part Number
A1 ¹	670-1706-00	B010100	B031509	CKT BOARD ASSY:ATTENUATOR	80009	670-1706-00
A1 ¹	670-1706-01	B031510		CKT BOARD ASSY:ATTENUATOR	80009	670-1706-01
A1 ²	670-1706-01	XB051370	B059999	CKT BOARD ASSY:ATTENUATOR	80009	670-1706-01
A1 ²	670-1706-02	B060000		CKT BOARD ASSY:ATTENUATOR	80009	670-1706-02
A2	670-1556-00	B010100	B059999	CKT BOARD ASSY:AMPLIFIER	80009	670-1556-00
A2	670-1556-01	B060000		CKT BOARD ASSY:AMPLIFIER	80009	670-1556-01
A3 ²	670-1385-00	B010100	B051369	CKT BOARD ASSY:READOUT	80009	670-1385-00
A3	670-1385-01	B051370		CKT BOARD ASSY:READOUT	80009	670-1385-01
C10	285-0816-01			CAP.,FXD,PLSTC:0.019UF,10%,600V	80009	285-0816-01
C47	283-0000-00			CAP.,FXD,CER DI:0.001UF,+100-0%,500V	72982	831-516E102P
C48	283-0000-00			CAP.,FXD,CER DI:0.001UF,+100-0%,500V	72982	831-516E102P
C100	281-0064-00			CAP.,VAR,PLSTC:0.25-1.5PF,600V	72982	530-002
C101	281-0661-00	B010100	B019999X	CAP.,FXD,CER DI:0.8PF,+/-0.1PF,500V	72982	301-000C0K0808B
C106						
C107	1 307-1010-00	B010100	B019999	ATTENUATOR,FXD:2X	80009	307-1010-00
C106						
C107	1 307-1010-01	B020000		ATTENUATOR,FXD:2X	80009	307-1010-01
C106						
C107	2 307-1010-00	B010100	B029999	ATTENUATOR,FXD:2X	80009	307-1010-00
C106						
C107	2 307-1010-01	B030000		ATTENUATOR,FXD:2X	80009	307-1010-01
C110						
C111	307-1011-00			ATTENUATOR,FXD:4X	80009	307-1011-00
C114						
C115	307-1013-00			ATTENUATOR,FXD:10X	80009	307-1013-00
C118						
C119	1 307-1014-00	B010100	B019999	ATTENUATOR,FXD:100X	80009	307-1014-00
C118						
C119	1 307-1014-01	B020000		ATTENUATOR,FXD:100X	80009	307-1014-01
C118						
C119	2 307-1014-00	B010100	B029999	ATTENUATOR,FXD:100X	80009	307-1014-00
C118						
C119	2 307-1014-01	B030000		ATTENUATOR,FXD:100X	80009	307-1014-01
C210	283-0001-00			CAP.,FXD,CER DI:0.005UF,+100-0%,500V	72982	831-559E502P
C212	281-0557-00			CAP.,FXD,CER DI:1.8PF,10%,500V	72982	301-000C0K0189B
C216	290-0512-00			CAP.,FXD,ELCTLT:22UF,20%,15V	56289	196D226X0015KA1
C225	281-0638-00			CAP.,FXD,CER DI:240PF,5%,500V	72982	301000Z5D241J
C231	283-0000-00			CAP.,FXD,CER DI:0.001UF,+100-0%,500V	72982	831-516E102P
C235	283-0000-00			CAP.,FXD,CER DI:0.001UF,+100-0%,500V	72982	831-516E102P
C240	281-0628-00			CAP.,FXD,CER DI:15PF,5%,500V	72982	301-000C0G0150J
C241	281-0517-00			CAP.,FXD,CER DI:39PF,+/-3.9PF,500V	72982	308-000C0G0390K
C243	281-0580-00			CAP.,FXD,CER DI:470PF,10%,500V	04222	7001-1374
C244	283-0000-00			CAP.,FXD,CER DI:0.001UF,+100-0%,500V	72982	831-516E102P
C250	281-0536-00			CAP.,FXD,CER DI:1000PF,10%,500V	72982	301055X5P102K
C261	281-0580-00			CAP.,FXD,CER DI:470PF,10%,500V	04222	7001-1374
C270	283-0002-00			CAP.,FXD,CER DI:0.01UF,+80-20%,500V	72982	811-546E103Z
C281	283-0002-00			CAP.,FXD,CER DI:0.01UF,+80-20%,500V	72982	811-546E103Z
C282	283-0002-00			CAP.,FXD,CER DI:0.01UF,+80-20%,500V	72982	811-546E103Z
C283	283-0002-00			CAP.,FXD,CER DI:0.01UF,+80-20%,500V	72982	811-546E103Z
C284	283-0002-00			CAP.,FXD,CER DI:0.01UF,+80-20%,500V	72982	811-546E103Z
C285	283-0002-00			CAP.,FXD,CER DI:0.01UF,+80-20%,500V	72982	811-546E103Z
C286	283-0002-00			CAP.,FXD,CER DI:0.01UF,+80-20%,500V	72982	811-546E103Z
C287	283-0002-00			CAP.,FXD,CER DI:0.01UF,+80-20%,500V	72982	811-546E103Z

¹7A15AN only.
²7A15A only.

Replaceable Electrical Parts—7A15A/AN

Ckt No.	Tektronix Part No.	Serial/Model No. Eff	Discont	Name & Description	Mfr Code	Mfr Part Number
C288	283-0002-00			CAP.,FXD,CER DI:0.01UF,+80-20%,500V	72982	811-546E103Z
C313	283-0000-00			CAP.,FXD,CER DI:0.001UF,+100-0%,500V	72982	831-516E102P
C316	290-0512-00			CAP.,FXD,ELCTLT:22UF,20%,15V	56289	196D226X0015KA1
C325	281-0638-00			CAP.,FXD,CER DI:240PF,5%,500V	72982	301000Z5D241J
C339	281-0509-00			CAP.,FXD,CER DI:15PF,+/-1.5PF,500V	72982	301-000C0G0150K
C341	281-0153-00			CAP.,VAR,AIR DI:1.7-10PF,250V	74970	187-0106-005
C343	281-0580-00			CAP.,FXD,CER DI:470PF,10%,500V	04222	7001-1374
C344	283-0000-00			CAP.,FXD,CER DI:0.001UF,+100-0%,500V	72982	831-516E102P
C345	283-0000-00			CAP.,FXD,CER DI:0.001UF,+100-0%,500V	72982	831-516E102P
C346	281-0592-00			CAP.,FXD,CER DI:4.7PF,+/-0.5PF,500V	72982	301-023C0H0479D
C350	281-0536-00			CAP.,FXD,CER DI:1000PF,10%,500V	72982	301055X5P102K
C361	281-0580-00			CAP.,FXD,CER DI:470PF,10%,500V	04222	7001-1374
C621 ¹	283-0000-00			CAP.,FXD,CER DI:0.001UF,+100-0%,500V	72982	831-516E102P
C630 ¹	283-0000-00			CAP.,FXD,CER DI:0.001UF,+100-0%,500V	72982	831-516E102P
C631 ¹	283-0000-00			CAP.,FXD,CER DI:0.001UF,+100-0%,500V	72982	831-516E102P
C634 ¹	283-0000-00			CAP.,FXD,CER DI:0.001UF,+100-0%,500V	72982	831-516E102P
C635 ¹	283-0000-00			CAP.,FXD,CER DI:0.001UF,+100-0%,500V	72982	831-516E102P
C638 ¹	283-0000-00			CAP.,FXD,CER DI:0.001UF,+100-0%,500V	72982	831-516E102P
C639 ¹	283-0000-00			CAP.,FXD,CER DI:0.001UF,+100-0%,500V	72982	831-516E102P
C641 ¹	283-0000-00			CAP.,FXD,CER DI:0.001UF,+100-0%,500V	72982	831-516E102P
C643 ¹	283-0000-00			CAP.,FXD,CER DI:0.001UF,+100-0%,500V	72982	831-516E102P
C647 ¹	283-0000-00			CAP.,FXD,CER DI:0.001UF,+100-0%,500V	72982	831-516E102P
C648 ¹	283-0003-00			CAP.,FXD,CER DI:0.01UF,+80-20%,150V	72982	855-558Z5U-103Z
C649 ¹	283-0000-00			CAP.,FXD,CER DI:0.001UF,+100-0%,500V	72982	831-516E102P
CR42 ¹	152-0185-00	B010100	B029999X	SEMICONV DEVICE:SILICON,40PIV,150MA	07910	1N4152
CR46 ¹	152-0185-00			SEMICONV DEVICE:SILICON,40PIV,150MA	07910	1N4152
CR210 ¹	152-0321-00			SEMICONV DEVICE:SILICON,35V,100MA	07263	FSA1480
CR621 ¹	152-0185-00			SEMICONV DEVICE:SILICON,40PIV,150MA	07910	1N4152
CR647 ¹	152-0185-00			SEMICONV DEVICE:SILICON,40PIV,150MA	07910	1N4152
J10 ¹	131-0679-00	B010100	B049999	CONNECTOR,RCPT,:BNC W/HARDWARE	24931	28JR168-1
J10 ¹	131-0679-02	B050000		CONNECTOR,RCPT,:BNC W/HARDWARE	24931	28JR270-1
J10 ²	131-0126-00			CONNECTOR,RCPT,:BNC,FEMALE	77820	9663-1 NT-34
L339	276-0507-00			SHIELDING BEAD,:0.6UH	78488	57-0180-7D 500B
LR281	108-0184-00			COIL,RF:3.2UH(WOUND ON A 10 OHM RESISTOR)	80009	108-0184-00
LR283	108-0184-00			COIL,RF:3.2UH(WOUND ON A 10 OHM RESISTOR)	80009	108-0184-00
LR285	108-0184-00			COIL,RF:3.2UH(WOUND ON A 10 OHM RESISTOR)	80009	108-0184-00
LR287	108-0184-00			COIL,RF:3.2UH(WOUND ON A 10 OHM RESISTOR)	80009	108-0184-00
Q210A,B	151-1032-00			TRANSISTOR:SILICON,FET,DUAL	80009	151-1032-00
Q220 ³	153-0596-00			SEMICONV DVC SE:SILICON,NPN	80009	153-0596-00
Q230 ⁴	153-0595-00			SEMICONV DVC SE:SILICON,NPN	80009	153-0595-00
Q235 ⁴	153-0595-00			SEMICONV DVC SE:SILICON,NPN	80009	153-0595-00
Q240 ⁵	153-0597-00			SEMICONV DVC SE:SILICON,PNP	80009	153-0597-00
Q245 ⁶	153-0597-00			SEMICONV DVC SE:SILICON,PNP	80009	153-0597-00
Q250	151-0221-00			TRANSISTOR:SILICON,PNP	80009	151-0221-00
Q260	151-0269-00			TRANSISTOR:SILICON,NPN,SEL FROM SE3005	80009	151-0269-00
Q270	151-0221-00			TRANSISTOR:SILICON,PNP	80009	151-0221-00
Q320 ⁷	153-0596-00			SEMICONV DVC SE:SILICON,NPN	80009	153-0596-00
Q330 ⁸	153-0595-00			SEMICONV DVC SE:SILICON,NPN	80009	153-0595-00
Q340 ⁹	153-0597-00			SEMICONV DVC SE:SILICON,PNP	80009	153-0597-00
Q345 ¹⁰	153-0597-00			SEMICONV DVC SE:SILICON,PNP	80009	153-0597-00
Q350	151-0221-00			TRANSISTOR:SILICON,PNP	80009	151-0221-00

¹7A15A only.

⁶Furnished as a matched pair with Q345.

²7A15AN only.

⁷Furnished as a matched pair with Q220.

³Furnished as a matched pair with Q320.

⁸Furnished as a matched quad with Q230 and Q235.

⁴Furnished as a matched quad with Q330 and Q335.

⁹Furnished as a matched pair with Q240.

⁵Furnished as a matched pair with Q340.

¹⁰Furnished as a matched pair with Q245.

Ckt No.	Tektronix Part No.	Serial/Model No. Eff	Dscont	Name & Description	Mfr Code	Mfr Part Number
Q360	151-0269-00			TRANSISTOR:SILICON,NPN,SEL FROM SE3005	80009	151-0269-00
Q370	151-0221-00			TRANSISTOR:SILICON,PNP	80009	151-0221-00
Q620 ¹	151-0254-00			TRANSISTOR:SILICON,NPN	80009	151-0254-00
R10	315-0620-00			RES.,FXD,CMPSN:62 OHM,5%,0.25W	01121	CB6205
R45 ²	311-1320-00			RES.,VAR, NONWIR:5K OHM,1W,W/SW	12697	381CM-39700
R45 ³	311-0310-00			RES.,VAR, NONWIR:5K OHM,20%,0.50W	01121	W-7350A
R46 ¹	316-0224-00			RES.,FXD,CMPSN:220K OHM,10%,0.25W	01121	CB2241
R47 ¹	315-0113-00			RES.,FXD,CMPSN:11K OHM,5%,0.25W	01121	CB1135
R48 ¹	316-0101-00			RES.,FXD,CMPSN:100 OHM,10%,0.25W	01121	CB1011
R102	317-0105-00			RES.,FXD,CMPSN:1M OHM,5%,0.125W	01121	BB1055
R130	322-0481-01			RES.,FXD,FILM:1M OHM,0.5%,0.25W	75042	CEBTO-1004D
R210	316-0474-00			RES.,FXD,CMPSN:470K OHM,10%,0.25W	01121	CB4741
R212	315-0561-00			RES.,FXD,CMPSN:560 OHM,5%,0.25W	01121	CB5615
R213	316-0470-00			RES.,FXD,CMPSN:47 OHM,10%,0.25W	01121	CB4701
R215	315-0391-00			RES.,FXD,CMPSN:390 OHM,5%,0.25W	01121	CB3915
R216	315-0911-00			RES.,FXD,CMPSN:910 OHM,5%,0.25W	01121	CB9115
R218	321-0032-00			RES.,FXD,FILM:21 OHM,1%,0.125W	91637	MFF1816G21R00F
R221	311-0633-00			RES.,VAR, NONWIR:5K OHM,10%,0.50W	80740	62-58-3
R223	323-0257-00			RES.,FXD,FILM:4.64K OHM,1%,0.50W	91637	MFF1226G46400F
R224	321-0032-00			RES.,FXD,FILM:21 OHM,1%,0.125W	91637	MFF1816G21R00F
R225	315-0471-00			RES.,FXD,CMPSN:470 OHM,5%,0.25W	01121	CB4715
R231	315-0821-00			RES.,FXD,CMPSN:820 OHM,5%,0.25W	01121	CB8215
R234	315-0241-00			RES.,FXD,CMPSN:240 OHM,5%,0.25W	01121	CB2415
R235	315-0821-00			RES.,FXD,CMPSN:820 OHM,5%,0.25W	01121	CB8215
R236	321-0122-00			RES.,FXD,FILM:182 OHM,1%,0.125W	91637	MFF1816G182R0F
R237	321-0153-00			RES.,FXD,FILM:383 OHM,1%,0.125W	91637	MFF1816G383R0F
R238	311-0310-00			RES.,VAR, NONWIR:5K OHM,20%,0.50W	01121	W-7350A
R239	311-1094-00			RES.,VAR, NONWIR:2.5K OHM,10%,0.50W	01121	GH-7709
R240	321-0118-00			RES.,FXD,FILM:165 OHM,1%,0.125W	91637	MFF1816G165R0F
R241	315-0302-00			RES.,FXD,CMPSN:3K OHM,5%,0.25W	01121	CB3025
R242	323-0255-00			RES.,FXD,FILM:4.42K OHM,1%,0.50W	75042	CECTO-4421F
R243	315-0241-00			RES.,FXD,CMPSN:240 OHM,5%,0.25W	01121	CB2415
R244	315-0471-00			RES.,FXD,CMPSN:470 OHM,5%,0.25W	01121	CB4715
R245	311-1007-00			RES.,VAR, NONWIR:20 OHM,20%,0.50W	73138	82-38-0
R246	316-0272-00			RES.,FXD,CMPSN:2.7K OHM,10%,0.25W	01121	CB2721
R247	316-0473-00			RES.,FXD,CMPSN:47K OHM,10%,0.25W	01121	CB4731
R248	311-0613-00			RES.,VAR, NONWIR:100K OHM,10%,0.50W	80740	62-63-3
R249	323-0255-00			RES.,FXD,FILM:4.42K OHM,1%,0.50W	75042	CECTO-4421F
R250	315-0241-00			RES.,FXD,CMPSN:240 OHM,5%,0.25W	01121	CB2415
R251	321-0137-00			RES.,FXD,FILM:261 OHM,1%,0.125W	91637	MFF1816G261R0F
R252	323-0153-00			RES.,FXD,FILM:383 OHM,1%,0.50W	75042	CECTO-3830F
R253	315-0103-00			RES.,FXD,CMPSN:10K OHM,5%,0.25W	01121	CB1035
R260	323-0210-00			RES.,FXD,FILM:1.5K OHM,1%,0.50W	75042	CECTO-1501F
R261	315-0241-00			RES.,FXD,CMPSN:240 OHM,5%,0.25W	01121	CB2415
R262	323-0164-00			RES.,FXD,FILM:499 OHM,1%,0.50W	75042	CECTO-4990F
R270	316-0331-00			RES.,FXD,CMPSN:330 OHM,10%,0.25W	01121	CB3311
R271	315-0152-00			RES.,FXD,CMPSN:1.5K OHM,5%,0.25W	01121	CB1525
R280	316-0470-00			RES.,FXD,CMPSN:47 OHM,10%,0.25W	01121	CB4701
R281	316-0470-00			RES.,FXD,CMPSN:47 OHM,10%,0.25W	01121	CB4701
R313	316-0105-00			RES.,FXD,CMPSN:1M OHM,10%,0.25W	01121	CB1051
R315	315-0391-00			RES.,FXD,CMPSN:390 OHM,5%,0.25W	01121	CB3915
R316	315-0911-00			RES.,FXD,CMPSN:910 OHM,5%,0.25W	01121	CB9115
R318	321-0032-00			RES.,FXD,FILM:21 OHM,1%,0.125W	91637	MFF1816G21R00F

¹7A15A only.

²7A15A only, furnished as a unit with S45.

³7A15AN only.

Replaceable Electrical Parts—7A15A/AN

Ckt No.	Tektronix Part No.	Serial/Model No. Eff	Dscont	Name & Description	Mfr Code	Mfr Part Number
R322	315-0123-00			RES.,FXD,CMPSN:12K OHM,5%,0.25W	01121	CB1235
R323	315-0131-00			RES.,FXD,CMPSN:130 OHM,5%,0.25W	01121	CB1315
R324	321-0032-00			RES.,FXD,FILM:21 OHM,1%,0.125W	91637	MFF1816G21R00F
R325	315-0471-00			RES.,FXD,CMPSN:470 OHM,5%,0.25W	01121	CB4715
R331	315-0621-00			RES.,FXD,CMPSN:620 OHM,5%,0.25W	01121	CB6215
R335	315-0621-00			RES.,FXD,CMPSN:620 OHM,5%,0.25W	01121	CB6215
R336	321-0122-00			RES.,FXD,FILM:182 OHM,1%,0.125W	91637	MFF1816G182R0F
R338	315-0621-00			RES.,FXD,CMPSN:620 OHM,5%,0.25W	01121	CB6215
R339	315-0131-00			RES.,FXD,CMPSN:130 OHM,5%,0.25W	01121	CB1315
R341	311-0634-00			RES.,VAR,NONWIR:500 OHM,10%,0.50W	80740	62-55-3
R342	323-0255-00			RES.,FXD,FILM:4.42K OHM,1%,0.50W	75042	CECT0-4421F
R343	315-0241-00			RES.,FXD,CMPSN:240 OHM,5%,0.25W	01121	CB2415
R344	315-0471-00			RES.,FXD,CMPSN:470 OHM,5%,0.25W	01121	CB4715
R345	315-0133-00			RES.,FXD,CMPSN:13K OHM,5%,0.25W	01121	CB1335
R349	323-0255-00			RES.,FXD,FILM:4.42K OHM,1%,0.50W	75042	CECT0-4421F
R350	315-0241-00			RES.,FXD,CMPSN:240 OHM,5%,0.25W	01121	CB2415
R351	321-0137-00			RES.,FXD,FILM:261 OHM,1%,0.125W	91637	MFF1816G261R0F
R352	321-0109-00			RES.,FXD,FILM:133 OHM,1%,0.125W	91637	MFF1816G133R0F
R353	315-0122-00			RES.,FXD,CMPSN:1.2K OHM,5%,0.25W	01121	CB1225
R360	323-0210-00			RES.,FXD,FILM:1.5K OHM,1%,0.50W	75042	CECT0-1501F
R361	315-0241-00			RES.,FXD,CMPSN:240 OHM,5%,0.25W	01121	CB2415
R362	323-0164-00			RES.,FXD,FILM:499 OHM,1%,0.50W	75042	CECT0-4990F
R371	315-0152-00			RES.,FXD,CMPSN:1.5K OHM,5%,0.25W	01121	CB1525
R621 ¹	321-0223-00			RES.,FXD,FILM:2.05K OHM,1%,0.125W	91637	MFF1816G20500F
R622 ¹	321-0296-00	B010100	B029999	RES.,FXD,FILM:11.8K OHM,1%,0.125W	91637	MFF1816G11801F
R622 ¹	321-0299-00	B030000		RES.,FXD,FILM:12.7K OHM,1%,0.125W	91637	MFF1816G12701F
R630 ¹	315-0154-00			RES.,FXD,CMPSN:150K OHM,5%,0.25W	01121	CB1545
R631 ¹	315-0753-00			RES.,FXD,CMPSN:75K OHM,5%,0.25W	01121	CB7535
R633 ¹	315-0753-00			RES.,FXD,CMPSN:75K OHM,5%,0.25W	01121	CB7535
R634 ¹	315-0154-00			RES.,FXD,CMPSN:150K OHM,5%,0.25W	01121	CB1545
R635 ¹	321-0344-00			RES.,FXD,FILM:37.4K OHM,1%,0.125W	91637	MFF1816G37401F
R637 ¹	315-0154-00			RES.,FXD,CMPSN:150K OHM,5%,0.25W	01121	CB1545
R638 ¹	315-0154-00			RES.,FXD,CMPSN:150K OHM,5%,0.25W	01121	CB1545
R639 ¹	315-0753-00			RES.,FXD,CMPSN:75K OHM,5%,0.25W	01121	CB7535
R640 ¹	315-0753-00			RES.,FXD,CMPSN:75K OHM,5%,0.25W	01121	CB7535
R641 ¹	315-0154-00			RES.,FXD,CMPSN:150K OHM,5%,0.25W	01121	CB1545
R642 ¹	315-0513-00			RES.,FXD,CMPSN:51K OHM,5%,0.25W	01121	CB5135
R643 ¹	321-0344-00			RES.,FXD,FILM:37.4K OHM,1%,0.125W	91637	MFF1816G37401F
R645 ¹	315-0154-00			RES.,FXD,CMPSN:150K OHM,5%,0.25W	01121	CB1545
R646 ¹	315-0154-00			RES.,FXD,CMPSN:150K OHM,5%,0.25W	01121	CB1545
R647 ¹	315-0133-00			RES.,FXD,CMPSN:13K OHM,5%,0.25W	01121	CB1335
R648 ¹	315-0154-00			RES.,FXD,CMPSN:150K OHM,5%,0.25W	01121	CB1545
S32	260-0816-00			SWITCH,SLIDE:DPDT,0.5A,125VAC	79727	GF-126-0012A
S45 ²						
S47A ¹	260-0816-00			SWITCH,SLIDE:DPDT,0.5A,125VAC	79727	GF-126-0012A
S100A						
S100B	672-0023-00	B010100	B051369	ACTR ASSY,CAM S:VOLTS/DIV	80009	672-0023-00
S100C ³						
S100A						
S100B	105-0485-00	B051370		DRUM,CAM SWITCH:VOLTS/DIV	80009	105-0485-00
S100C ³						
S100A						

¹7A15A only.

²7A15A only, furnished as a unit with R45.

³7A15A only, see Mechanical Parts List for replacement parts.

Replaceable Electrical Parts—7A15A/AN

Ckt No.	Tektronix Part No.	Serial/Model No. Eff	Dscont	Name & Description	Mfr Code	Mfr Part Number
S100B S100C ¹ S100A	670-1706-00	B010100	B031509	ACTR ASSY,CAM S:VOLTS/DIV	80009	670-1706-00
S100B S100C ¹	105-0485-00	B031510		DRUM,CAM SWITCH:VOLTS/DIV	80009	105-0485-00
S239 ²						

¹7A15AN only, see Mechanical Parts List for replacement.
²Furnished as a unit with R239.

SECTION 7

DIAGRAMS AND CIRCUIT BOARD ILLUSTRATIONS

Symbols and Reference Designators

Electrical components shown on the diagrams are in the following units unless noted otherwise:

- Capacitors = Values one or greater are in picofarads (pF).
 Values less than one are in microfarads (μ F).
 Resistors = Ohms (Ω)

Symbols used on the diagrams are based on USA Standard Y32.2-1967.

The following special symbols are used on the diagrams:

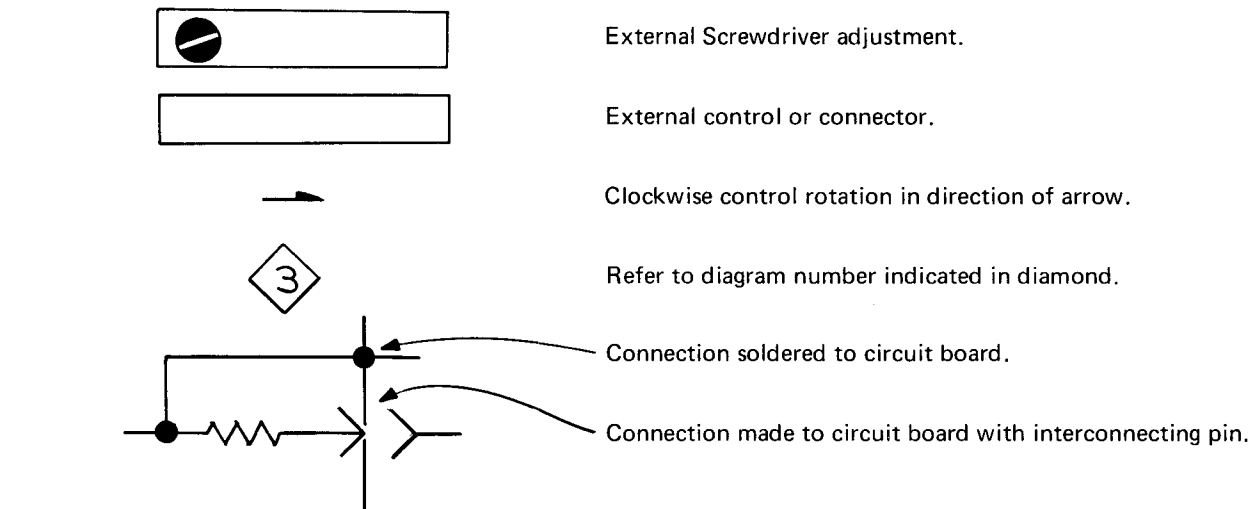

The following prefix letters are used as reference designators to identify components or assemblies on the diagrams.

A	Assembly, separable or repairable (circuit board, etc.)	LR	Inductor/resistor combination
AT	Attenuator, fixed or variable	M	Meter
B	Motor	Q	Transistor or silicon-controlled rectifier
BT	Battery	P	Connector, movable portion
C	Capacitor, fixed or variable	R	Resistor, fixed or variable
CR	Diode, signal or rectifier	RT	Thermistor
DL	Delay line	S	Switch
DS	Indicating device (lamp)	T	Transformer
F	Fuse	TP	Test point
FL	Filter	U	Assembly, inseparable or non-repairable (integrated circuit, etc.)
H	Heat dissipating device (heat sink, heat radiator, etc.)	V	Electron tube
HR	Heater	VR	Voltage regulator (zener diode, etc.)
J	Connector, stationary portion	Y	Crystal
K	Relay		
L	Inductor, fixed or variable		

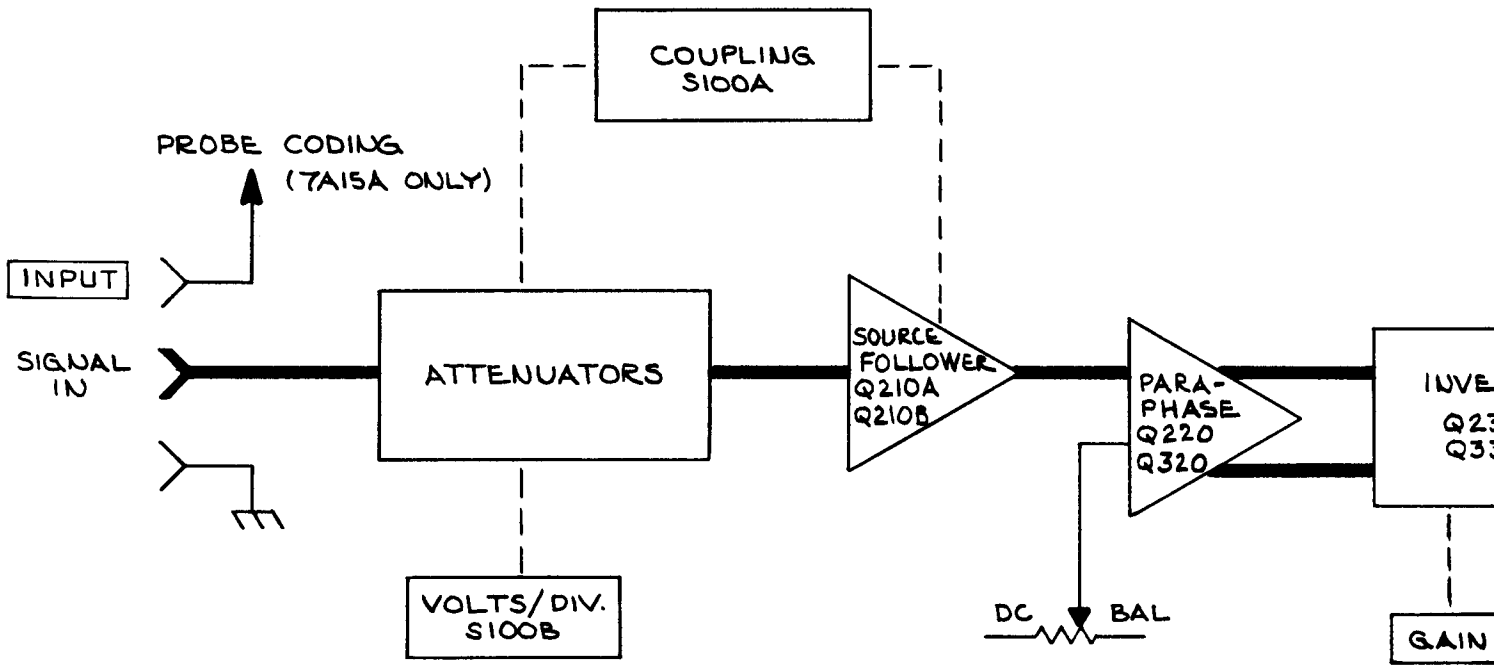

7A15A / 7A15AN

(A)

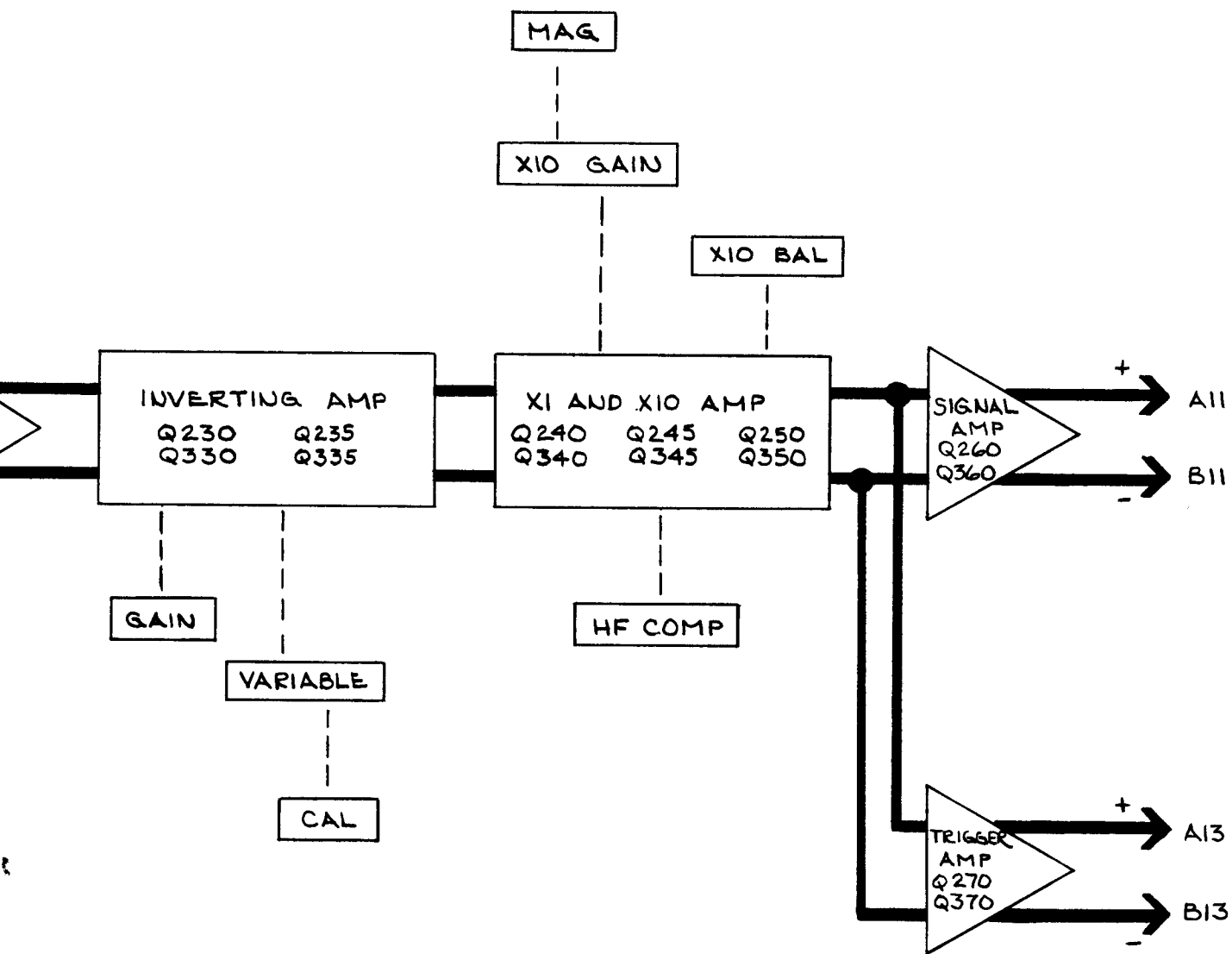

Ⓐ

BLOCK DIAGRAM

671
RH

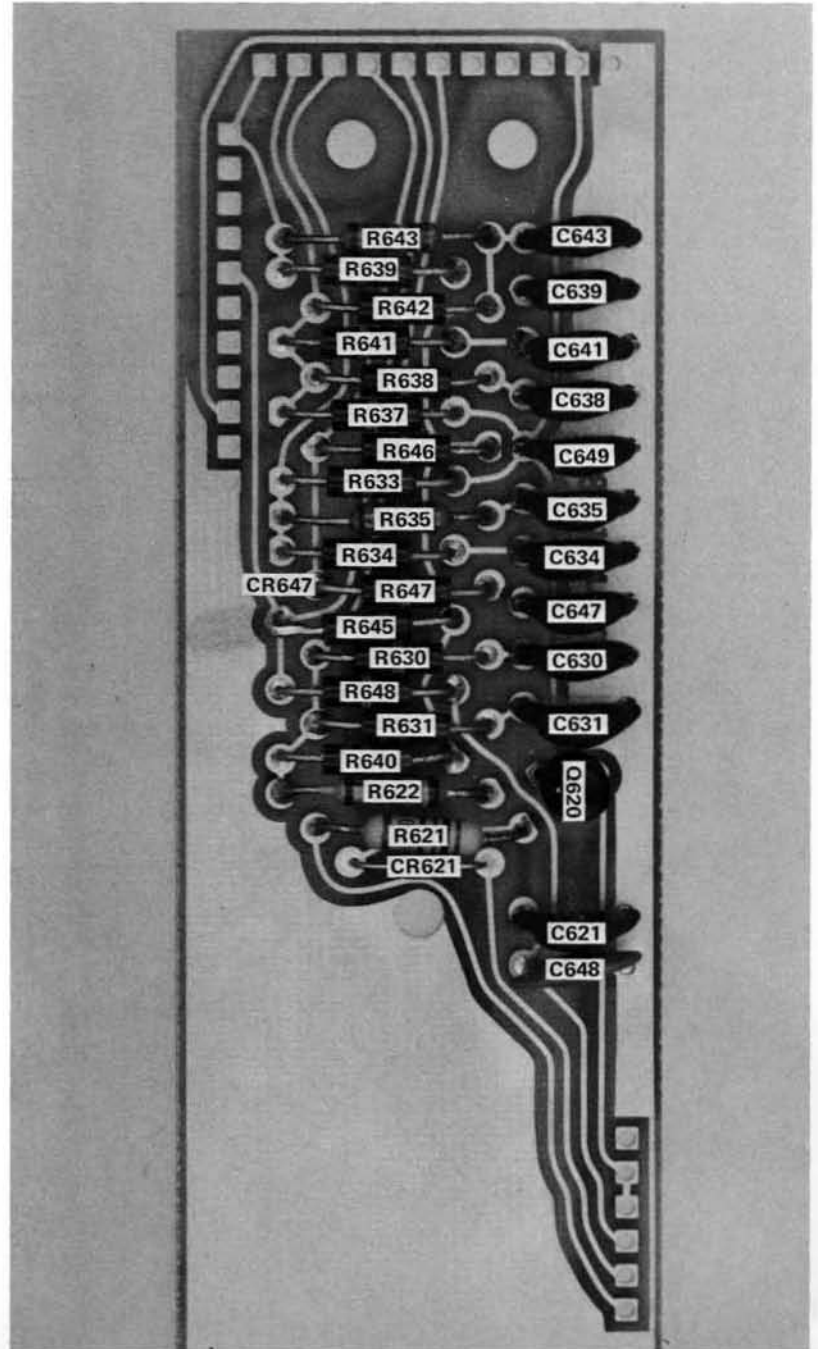
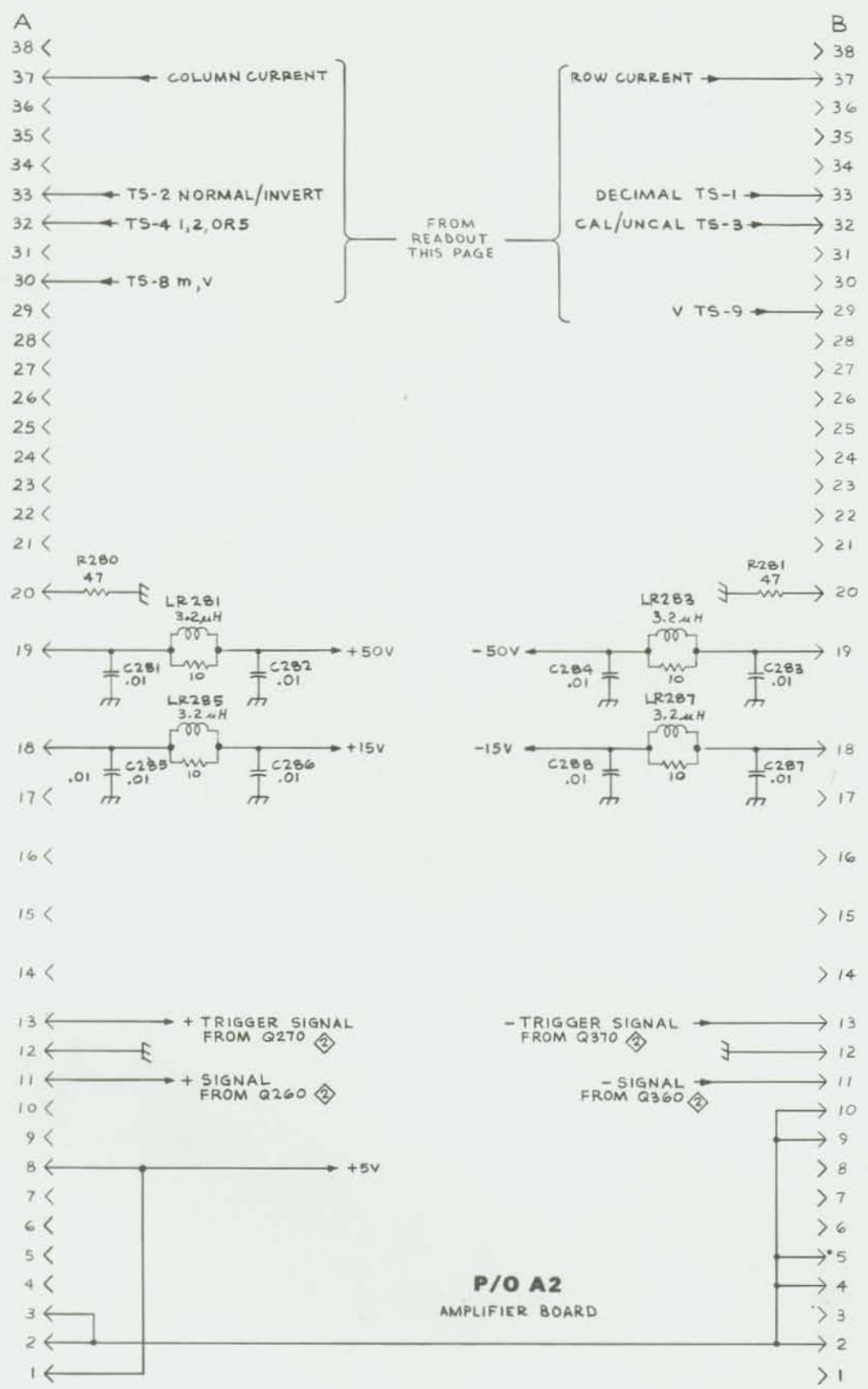
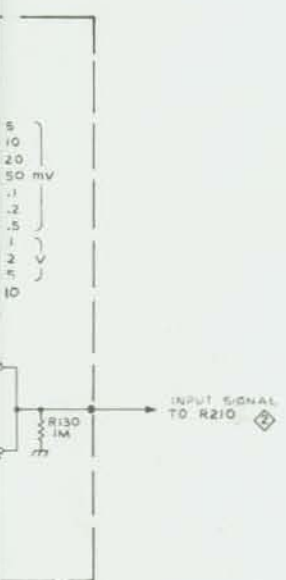
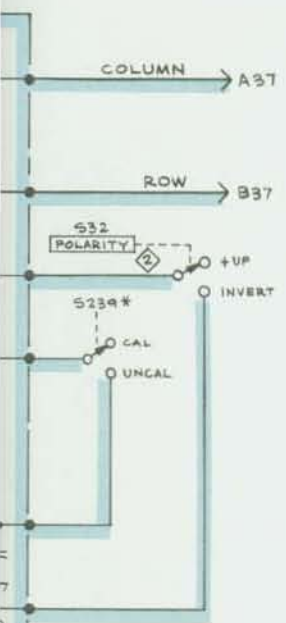

Fig. 7-1. Readout circuit board with component location (7A15A Only).

D WITH R239



P/O A2
AMPLIFIER BOARD

VOLTAGES AND WAVEFORMS

The voltages and waveforms shown on this diagram were obtained by using the recommended test equipment and test set-ups listed below.

RECOMMENDED TEST EQUIPMENT

ITEM	SPECIFICATIONS	RECOMMENDED TYPE
Oscilloscope	Frequency response DC to 65 MHz Deflection factor 5 mV to 5 V/Div Input impedance 10 M Ω , 20 pF Sweep rate 500 ns	Tektronix 7603 or 7613 equipped with 7A15A Amplifier and 7B50 Time-Base Unit, or equivalent.
Probe	Fast rise 10X attenuation probe compatible with the vertical amplifier of the test oscilloscope.	Tektronix P6053A, or equivalent.
Voltmeter (Non-loading digital multimeter)	Input impedance 10 M Ω Range 0 – 500 V	Tektronix 7D13 Digital Multimeter (test oscilloscope must have readout system) or Fairchild Model 7050, or equivalent.
Extender	Required for extending the 7A15AN from the mainframe when making waveform and voltage measurements.	Tektronix extender plug-in. Tektronix Part Number 067-0589-00 or Tektronix flexible extender, Tektronix Part Number 067-0616-00, or equivalent.

Test Set-Up

The test oscilloscope 1 kHz, 400 mV calibrator output is applied to the input of the 7A15A and to the external trigger of the test oscilloscope. The 7A15A under test must be connected to a mainframe separate from the test oscilloscope.

7A15AN Control Settings

CONTROLS	SETTINGS
VOLTS/DIV.	100 mV/Division
COUPLING	AC
POLARITY	+UP
MAG.	X1
POSITION	To center

Tolerances of voltages and waveforms shown are $\pm 20\%$.

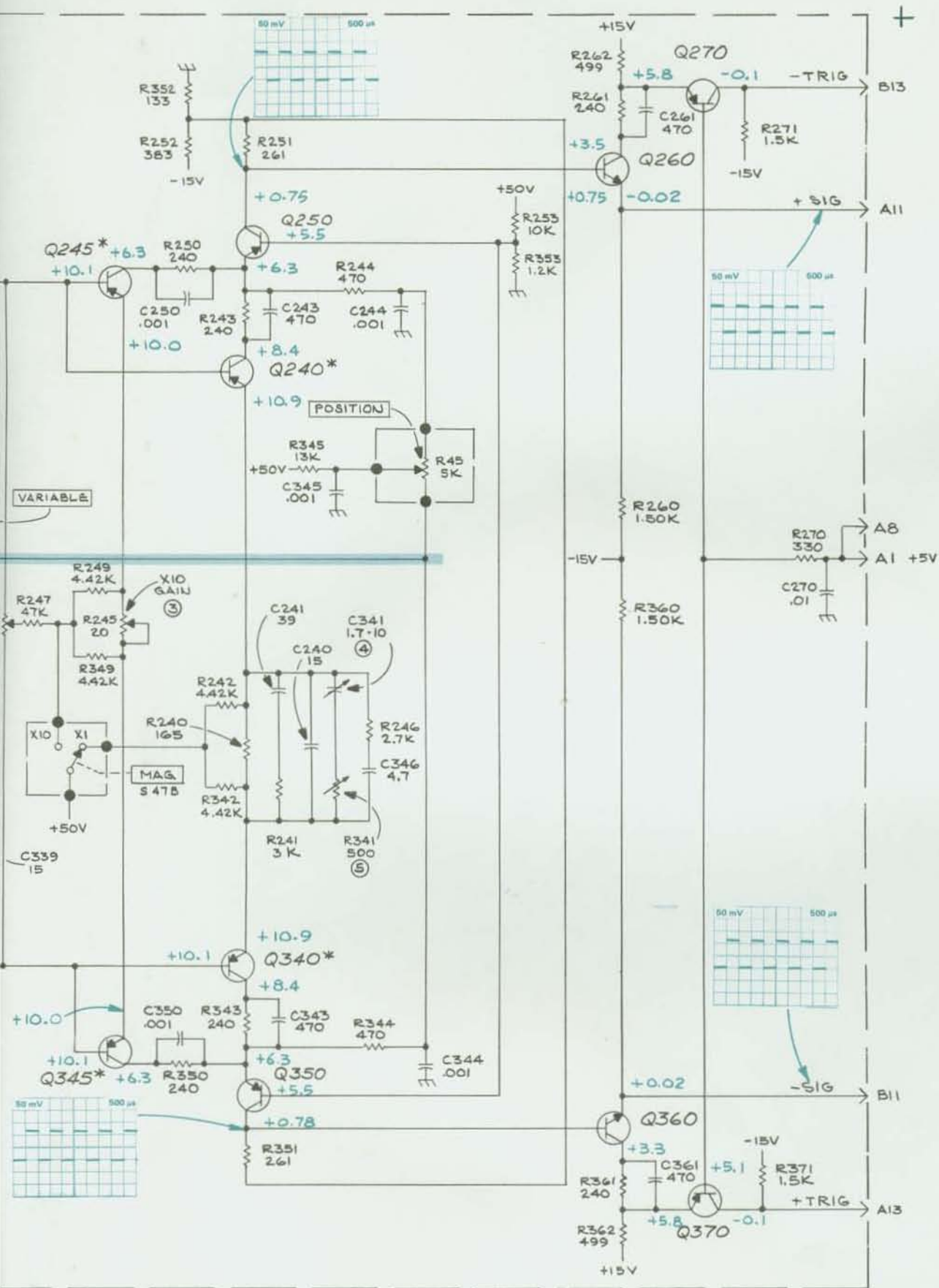

REPLACEABLE MECHANICAL PARTS

PARTS ORDERING INFORMATION

Replacement parts are available from or through your local Tektronix, Inc. Field Office or representative.

Changes to Tektronix instruments are sometimes made to accommodate improved components as they become available, and to give you the benefit of the latest circuit improvements developed in our engineering department. It is therefore important, when ordering parts, to include the following information in your order: Part number, instrument type or number, serial number, and modification number if applicable.

If a part you have ordered has been replaced with a new or improved part, your local Tektronix, Inc. Field Office or representative will contact you concerning any change in part number.

Change information, if any, is located at the rear of this manual.

SPECIAL NOTES AND SYMBOLS

X000 Part first added at this serial number
00X Part removed after this serial number

FIGURE AND INDEX NUMBERS

Items in this section are referenced by figure and index numbers to the illustrations.

INDENTATION SYSTEM

This mechanical parts list is indented to indicate item relationships. Following is an example of the indentation system used in the description column.

```

1 2 3 4 5           Name & Description
Assembly and/or Component
Attaching parts for Assembly and/or Component
    --- * ---
Detail Part of Assembly and/or Component
Attaching parts for Detail Part
    --- * ---
Parts of Detail Part
Attaching parts for Parts of Detail Part
    --- * ---
  
```

Attaching Parts always appear in the same indentation as the item it mounts, while the detail parts are indented to the right. Indented items are part of, and included with, the next higher indentation. The separation symbol --- * --- indicates the end of attaching parts.

Attaching parts must be purchased separately, unless otherwise specified.

ITEM NAME

In the Parts List, an Item Name is separated from the description by a colon (:). Because of space limitations, an Item Name may sometimes appear as incomplete. For further Item Name identification, the U.S. Federal Cataloging Handbook H6-1 can be utilized where possible.

ABBREVIATIONS

"	INCH	ELCTRN	ELECTRON	IN	INCH	SE	SINGLE END
#	NUMBER SIZE	ELEC	ELECTRICAL	INCAND	INCANDESCENT	SECT	SECTION
ACTR	ACTUATOR	ELCTLT	ELECTROLYTIC	INSUL	INSULATOR	SEMICON	SEMICONDUCTOR
ADPTR	ADAPTER	ELEM	ELEMENT	INTL	INTERNAL	SHLD	SHIELD
ALIGN	ALIGNMENT	EPL	ELECTRICAL PARTS LIST	LPHLDR	LAMPHOLDER	SHLDR	SHOULDERED
AL	ALUMINUM	EQPT	EQUIPMENT	MACH	MACHINE	SKT	SOCKET
ASSEM	ASSEMBLED	EXT	EXTERNAL	MECH	MECHANICAL	SL	SLIDE
ASSY	ASSEMBLY	FIL	FILLISTER HEAD	MTG	MOUNTING	SLFLKG	SELF-LOCKING
ATTEN	ATTENUATOR	FLEX	FLEXIBLE	NIP	NIPPLE	SLVG	SLEEVEING
AWG	AMERICAN WIRE GAGE	FLH	FLAT HEAD	NON WIRE	NOT WIRE WOUND	SPR	SPRING
BD	BOARD	FLTR	FILTER	OBD	ORDER BY DESCRIPTION	SQ	SQUARE
BRKT	BRACKET	FR	FRAME or FRONT	OD	OUTSIDE DIAMETER	SST	STAINLESS STEEL
BRS	BRASS	FSTNR	FASTENER	OVB	OVAL HEAD	STL	STEEL
BRZ	BRONZE	FT	FOOT	PH BRZ	PHOSPHOR BRONZE	SW	SWITCH
BSHG	BUSHING	FXD	FIXED	PL	PLAIN or PLATE	T	TUBE
CAB	CABINET	GSKT	GASKET	PLSTC	PLASTIC	TERM	TERMINAL
CAP	CAPACITOR	HDL	HANDLE	PN	PART NUMBER	THD	THREAD
CER	CERAMIC	HEX	HEXAGON	PNH	PAN HEAD	THK	THICK
CHAS	CHASSIS	HEX HD	HEXAGONAL HEAD	PWR	POWER	TNSN	TENSION
CKT	CIRCUIT	HEX SOC	HEXAGONAL SOCKET	RCPT	RECEPTACLE	TPG	TAPPING
COMP	COMPOSITION	HLCPS	HELICAL COMPRESSION	RES	RESISTOR	TRH	TRUSS HEAD
CONN	CONNECTOR	HLEXT	HELICAL EXTENSION	RGD	RIGID	V	VOLTAGE
COV	COVER	HV	HIGH VOLTAGE	RLF	RELIEF	VAR	VARIABLE
CPLG	COUPLING	IC	INTEGRATED CIRCUIT	RTNR	RETAINER	W	WITH
CRT	CATHODE RAY TUBE	ID	INSIDE DIAMETER	SCH	SOCKET HEAD	WSHR	WASHER
DEG	DEGREE	IDNT	IDENTIFICATION	SCOPE	OSCILLOSCOPE	XFMR	TRANSFORMER
DWR	DRAWER	IMPLR	IMPELLER	SCR	SCREW	XSTR	TRANSISTOR

CROSS INDEX—MFR. CODE NUMBER TO MANUFACTURER

Mfr. Code	Manufacturer	Address	City, State, Zip
00779	AMP, INC.	P O BOX 3608	HARRISBURG, PA 17105
08261	SPECTRA-STRIP CORP.	7100 LAMPSON AVE.	GARDEN GROVE, CA 92642
12327	FREEWAY CORPORATION	9301 ALLEN DRIVE	CLEVELAND, OH 44125
12360	ALBANY PRODUCTS CO., DIV. OF PNEUMO DYNAMICS CORPORATION	145 WOODWARD AVENUE	SOUTH NORWALK, CT 06586
13257	AMERACE, LTD.	10 ESNA PARK DRIVE	MARKHAM, ONTARIO, CANADA
22526	BERG ELECTRONICS, INC.	YOUK EXPRESSWAY	NEW CUMBERLAND, PA 17070
24931	SPECIALTY CONNECTOR CO., INC.	3560 MADISON AVE.	INDIANAPOLIS, IN 46227
42838	NATIONAL RIVET AND MFG. CO.	1-21 EAST JEFFERSON ST.	WAUPUN, WI 53963
70278	ALLIED STEEL AND CONVEYORS, DIV. OF SPARTON CORP.	17333 HEALY	DETROIT, MI 48212
73743	FISCHER SPECIAL MFG. CO.	446 MORGAN ST.	CINCINNATI, OH 45206
74445	HOLO-KROME CO.	31 BROOK ST. WEST	HARTFORD, CT 06110
77250	PHEOLL MANUFACTURING CO., DIVISION OF ALLIED PRODUCTS CORP.	5700 W. ROOSEVELT RD.	CHICAGO, IL 60650
77820	BENDIX CORP., THE, ELECTRICAL COMPONENTS DIVISION	SHERMAN AVE.	SIDNEY, NY 13838
78189	ILLINOIS TOOL WORKS, INC. SHAKEPROOF DIVISION	ST. CHARLES ROAD	ELGIN, IL 60120
79727	C-W INDUSTRIES	550 DAVISVILLE RD., P O BOX 96	WARMINISTER, PA 18974
80009	TEKTRONIX, INC.	P O BOX 500	BEAVERTON, OR 97077
83385	CENTRAL SCREW CO.	2530 CRESCENT DR.	BROADVIEW, IL 60153
87308	N. L. INDUSTRIES, INC., SOUTHERN SCREW DIV.	P. O. BOX 1360	STATESVILLE, NC 28677
97464	INDUSTRIAL RETAINING RING CO.	57 CORDIER ST.	IRVINGTON, NJ 07111

Replaceable Mechanical Parts—7A15A/AN

Fig. & Index No.	Tektronix Part No.	Serial/Model No. Eff Dscont	Qty	1	2	3	4	5	Name & Description	Mfr Code	Mfr Part Number
1-1	366-1058-33 ¹		1						KNOB:LATCH		
-2	366-1058-34 ²		1						KNOB:LATCH		
	366-1058-39 ³		1						KNOB:LATCH	80009	366-1058-39
									(ATTACHING PARTS)		
-3	214-1095-00		1						PIN,SPG,SPLIT:0.094 OD X 0.187 INCH LONG	13257	52-022-094-0187
									-----*		
-4	105-0076-00		1						REL BAR,LATCH:PLUG-IN UNIT	80009	105-0076-00
-5	214-1280-00		1						SPRING,HLCPS:0.14 OD X 1.126"L,0.16"DIA W	80009	214-1280-00
-6	214-1054-00		1						SPRING,DETENT:LATCH	80009	214-1054-00
-7	105-0075-00		1						PAWL:0.475 X 0.21 X 0.184 INCH,PLSTC	80009	105-0075-00
-8	348-0235-00		2						SHLD GSKT,ELEC:4.734 INCH LONG	80009	348-0235-00
-9	366-1059-00 ¹		1						PUSH BUTTON:GRAY	80009	366-1059-00
-10	366-1077-00 ¹		1						KNOB:GRAY	80009	366-1077-00
	213-0153-00		1						. SETSCREW:5-40 X 0.125 INCH,HEX SOC STL	74445	OBD
-11	366-0494-00 ²		1						KNOB:GRAY	80009	366-0494-00
	213-0153-00		1						. SETSCREW:5-40 X 0.125 INCH,HEX SOC STL	74445	OBD
-12	366-1031-03		1						KNOB:RED--CAL	80009	366-1031-03
	213-0153-00		1						. SETSCREW:5-40 X 0.125 INCH,HEX SOC STL	74445	OBD
-13	366-1299-00		1						KNOB:GRAY	80009	366-1299-00
	213-0153-00		1						. SETSCREW:5-40 X 0.125 INCH,HEX SOC STL	74445	OBD
-14	358-0378-00 ¹		1						BUSHING,SLEEVE:PRESS MOUNT	80009	358-0378-00
-15	333-1474-00 ¹		1						PANEL,FRONT:		
-16	333-1475-00 ²		1						PANEL,FRONT:		
-17	366-0215-02		1						KNOB:LEVER SWITCH	80009	366-0215-02
-18	131-0679-00 ¹	B010100 B049999	1						CONNECTOR,RCPT,:BNC W/HARDWARE	24931	28JRL68-1
	131-0679-02	B050000	1						CONNECTOR,RCPT,:BNC W/HARDWARE	24931	28JRT70-1
									(ATTACHING PARTS)		
	210-1039-00	XB050000	1						WASHER,LOCK:INT,0.521 ID X 0.625 INCH OD T	24931	OBD
	220-0497-00	XB050000	1						NUT,PLAIN,HEX.:0.5-28 X 0.562 INCH HEX,BRS	73743	OBD
-19	220-0569-00		1						NUT,PLAIN,KNURL:0.50-28 X 0.235 INCH BRS	80009	220-0569-00
									-----*		
-20	131-0126-00 ²		1						CONNECTOR,RCPT,:BNC,FEMALE	77820	9663-1 NT-34
									(ATTACHING PARTS)		
	220-0569-00		1						NUT,PLAIN,KNURL:0.50-28 X 0.235 INCH BRS	80009	220-0569-00
									-----*		
-21	260-0816-00		2						SWITCH,SLIDE:DPDT,0.5A,125VAC	79727	GF-126-0012A
									(ATTACHING PARTS)		
-22	211-0030-00		2						SCREW,MACHINE:2-56 X 0.25"82 DEG,FLH STL	83385	OBD
-23	210-0405-00		2						NUT,PLAIN,HEX.:2-56 X 0.188 INCH,BRS	73743	2X12157-402
									-----*		
-24	----- ¹		1						RESISTOR,VARIABLE		
									(ATTACHING PARTS)		
-25	210-0583-00		2						NUT,PLAIN,HEX.:0.25-32 X 0.312 INCH,BRS	73743	2X20224-402
-26	210-0046-00		1						WASHER,LOCK:INTL,0.26 ID X 0.40" OD,STL	78189	1214-05-00-0541C
									-----*		
-27	----- ²		1						RESISTOR,VARIABLE		
									(ATTACHING PARTS)		
-28	210-0583-00		2						NUT,PLAIN,HEX.:0.25-32 X 0.312 INCH,BRS	73743	2X20224-402
-29	210-0046-00		1						WASHER,LOCK:INTL,0.26 ID X 0.40" OD,STL	78189	1214-05-00-0541C
									-----*		
-30	386-1447-54		1						SUBPANEL,FRONT:	80009	386-1447-54
									(ATTACHING PARTS)		
-31	213-0192-00		4						SCR,TFG,THD FOR:6-32 X 0.50 INCH,PNH STL	87308	OBD
									-----*		
-32	337-1064-02	B010100 B039999	2						SHLD,ELECTRICAL:SIDE PLUG-IN UNIT		
	337-1064-06	B040000	2						SHLD,ELECTRICAL:SIDE PLUG-IN UNIT		
-33	-----		1						CKT BOARD ASSY:AMPLIFIER(SEE A2 EPL)		
-34	136-0252-04	B010100 B041329	53						. SOCKET,PIN TERM:0.188 INCH LONG	22526	75060
	136-0252-04	B041330	5						. SOCKET,PIN TERM:0.188 INCH LONG	22526	75060
	136-0350-00	XB041330	16						. SOCKET,PLUG-IN:3 PIN,LOW PROFILE	80009	136-0350-00
-35	200-0945-00		3						. COVER,HALF XSTR:FOR DUAL TO-18 CASE	80009	200-0945-00
-36	200-0945-01		3						. COVER,HALF XSTR:FOR DUAL TO-18 CS,2-56 THD	80009	200-0945-01
-37	211-0001-00		3						. SCREW,MACHINE:2-56 X 0.25 INCH,PNH STL	83385	OBD

¹7A15A only (does not apply to 7A15AN Option 11)

²7A15AN only.

³7A15AN (Option 11)

Replaceable Mechanical Parts—7A15A/AN

Fig. & Index No.	Tektronix Part No.	Serial/Model No. Eff	Dscont	Qty	1	2	3	4	5	Name & Description	Mfr Code	Mfr Part Number
1-	124-0162-00			1	.					TERMINAL BOARD:4 NOTCH	80009	124-0162-00
	355-0046-00			1	.					MOUNT,TERM. BD:0.577 INCH H	80009	355-0046-00
-38	407-0976-00			1	.					BRACKET,COMP:		
-39	-----			2	.					RESISTOR,VARIABLE		
										(ATTACHING PARTS FOR EACH)		
-40	210-0583-00			1	.					NUT,PLAIN,HEX.:0.25-32 X 0.312 INCH,BRS	73743	2X20224-402
-41	210-0046-00			1	.					WASHER,LOCK:INTL,0.26 ID X 0.40" OD,STL	78189	1214-05-00-0541C
										-----*		
										(ATTACHING PARTS FOR CKT BD)		
-42	211-0008-00			4	SCREW,MACHINE:4-40 X 0.25 INCH,PNH STL						83385	OBD
										-----*		
-43	376-0029-00			2	CPLG,SHAFT,RGD:0.128 ID X 0.312 OD X 0.5"L						80009	376-0029-00
-44	384-1111-00			1	EXTENSION SHAFT:7.04 L X 0.125 INCH OD						80009	384-1111-00
-45	384-1112-00			1	EXTENSION SHAFT:0.50 L X 0.125 INCH OD						80009	384-1112-00
-46	384-1110-00			1	EXTENSION SHAFT:8.122 L X 0.124 INCH OD						80009	384-1110-00
-47	220-0547-01			4	NUT,BLOCK:0.38 X 0.25 X 0.282"OA						80009	220-0547-01
										(ATTACHING PARTS FOR EACH)		
-48	211-0105-00			1	SCREW,MACHINE:4-40 X 0.188"100 DEG,FLH STL						83385	OBD
										-----*		
-49	214-1061-00			1	SPRING,GROUND:FLAT						80009	214-1061-00
-50	386-1402-00			1	PANEL,REAR:						80009	386-1402-00
										(ATTACHING PARTS)		
-51	213-0192-00			4	SCR,TPG,THD FOR:6-32 X 0.50 INCH,PNH STL						87308	OBD
-52	361-0326-00			1	SPACER,SLEEVE:0.18 ID X 0.25 OD X 0.10"L						80009	361-0326-00
										-----*		
-53	426-0736-00			1	FR SECT,PLUG-IN:TOP						80009	426-0736-00
-54	210-0288-00			1	TERMINAL,LUG:0.125 ID X 1.125 INCH LONG						80009	210-0288-00
										(ATTACHING PARTS)		
-55	211-0105-00			1	SCREW,MACHINE:4-40 X 0.188"100 DEG,FLH STL						83385	OBD
-56	210-0586-00			1	NUT,PLAIN,EXT W:4-40 X 0.25 INCH,STL						78189	OBD
										-----*		
	124-0138-00			1	TERMINAL,STRIP:						80009	124-0138-00
-57	426-0737-00			1	FR SECT,PLUG-IN:BOTTOM						80009	426-0737-00
-58	129-0080-00 ¹			1	POST,ELEC-MECH:0.875 INCH LONG						80009	129-0080-00
										(ATTACHING PARTS)		
-59	211-0088-00			2	SCREW,MACHINE:2-56 X 0.281"82 DEG,FLH STL						77250	OBD
										-----*		
-60	200-1199-00			1	COVER,ATTEN:							
										(ATTACHING PARTS)		
-61	211-0007-00			4	SCREW,MACHINE:4-40 X 0.188 INCH,PNH STL						83385	OBD
-62	210-0994-00			4	WASHER,FLAT:0.125 ID X 0.25" OD,STL						83385	OBD
										-----*		
-63	337-1423-00			1	SHLD,ATTEN:FRONT							
										(ATTACHING PARTS)		
-64	213-0055-00			1	SCR,TPG,THD FOR:2-32 X 0.188 INCH,PNH STL						83385	OBD
										-----*		
-65	407-0977-00			1	BRACKET,CKT BD:							
										(ATTACHING PARTS)		
-66	211-0008-00			2	SCREW,MACHINE:4-40 X 0.25 INCH,PNH STL						83385	OBD
-67	210-0586-00			1	NUT,PLAIN,EXT W:4-40 X 0.25 INCH,STL						78189	OBD
										-----*		
	-----	2		1	CKT BOARD ASSY:ATTENUATOR(SEE A1 EPL)							
	-----	1		1	CKT BOARD ASSY:ATTENUATOR(SEE A1 EPL)							
	105-0485-00	XB030000		1	ACTUATOR ASSY:							
	672-0023-00	1		1	CKT BOARD ASSY:READOUT ATTENUATOR							
-68	-----	1		1	CKT BOARD ASSY:READOUT(SEE A3 EPL)							
	-----	1		1	CKT BOARD ASSY:READOUT(SEE A3 EPL)							
-69	136-0252-04	B010100 B029999		3	SOCKET,PIN TERM:0.188 INCH LONG						22526	75060
	136-0350-00	B041330		2	SOCKET,PLUG-IN:3 PIN,LOW PROFILE						80009	136-0350-00
	210-0779-00			7	RIVET,TUBULAR:0.051 OD X 0.115 INCH LONG						42838	RA-29952715
-70	131-1031-00 ¹			7	CONTACT ASSY,EL:CAM SWITCH,TOP						80009	131-1031-00

¹7A15A only.
²7A15AN only.

Fig. & Index No.	Tektronix Part No.	Serial/Model No. Eff	Dscont	Qty	1	2	3	4	5	Name & Description	Mfr Code	Mfr Part Number
1-71	337-1418-01			2	.					SHIELD,ELEC:CAM SWITCH (ATTACHING PARTS)	80009	337-1418-01
-72	213-0277-00	B010100	B051919	3	.					SCR,TPG,THD FOR:2-56 X 0.312 INCH,PNH STL	83385	OBD
	211-0001-00	B051920		12	.					SCREW,MACHINE:2-56 X 0.25 INCH,PNH STL	83385	OBD
	210-1008-00			3	.					WASHER,FLAT:0.09 ID X 0.188" OD,BRS	12360	OBD
-73	210-0053-00			3	.					WASHER,LOCK:INTL,0.092 ID X 0.175"OD,STL	83385	OBD
										- - - * - - -		
-74	105-0243-00			1	.					ACTUATOR,SWITCH: (ATTACHING PARTS)	80009	105-0243-00
-75	213-0214-00			1	.					SCREW,CAP SCH:2-56 X 0.375"HEX HD STL	70278	OBD
										- - - * - - -		
	105-0485-00	XB030000		1	.					ACTUATOR,CAM SW:		
-76	200-1227-00 ¹			1	.					COVER,CAM SW:3 AND 24 CAM CONC (ATTACHING PARTS)		
-77	211-0116-00			4	.					SCR,ASSEM WSHR:4-40 X 0.312 INCH,PNH BRS	83385	OBD
										- - - * - - -		
-78	354-0391-00			2	.					RING,RETAINING:0.395"FREE ID X 0.025" STL	97464	3100-43-CD
-79	214-1127-00			4	.					ROLLER,DETENT:0.125 DIA X 0.125 INCH L	80009	214-1127-00
-80	214-1139-00			1	.					SPRING,FLAT:GOLD COLORED	80009	214-1139-00
	214-1139-02			2	.					SPRING,FLAT:GREEN COLORED	80009	214-1139-02
	214-1139-03			2	.					SPRING,FLAT:RED COLORED	80009	214-1139-03
-81	401-0081-02			1	.					BEARING,CAM SW:FRONT	80009	401-0081-02
-82	131-0963-00			2	.					CONTACT,ELEC:GROUNDING	80009	131-0963-00
-83	210-0406-00			2	.					NUT,PLAIN,HEX :4-40 X 0.188 INCH,BRS	73743	2X12161-402
-84	401-0081-02			1	.					BEARING,CAM SW:FRONT	80009	401-0081-02
-85	210-0406-00			4	.					NUT,PLAIN,HEX :4-40 X 0.188 INCH,BRS	73743	2X12161-402
-86	105-0242-00			1	.					DRUM,CAM SWITCH:AC GND DC		
-87	401-0115-00			1	.					BEARING,CAM SW:CENTER	80009	401-0115-00
-88	210-0406-00			4	.					NUT,PLAIN,HEX :4-40 X 0.188 INCH,BRS	73743	2X12161-402
-89	105-0272-00			1	.					DRUM,CAM SWITCH:VOLTS/DIV (ATTACHING PARTS)		
-90	211-0097-00			2	.					SCREW,MACHINE:4-40 X 0.312 INCH,PNH STL	83385	OBD
-91	210-0004-00			2	.					WASHER,LOCK:INTL,0.12 ID X 0.26"OD,STL	78189	1204-00-00-0541C
-92	129-0299-00			2	.					POST,ELEC-MECH:HEX,0.333 INCH LONG	80009	129-0299-00
-93	210-0004-00			2	.					WASHER,LOCK:INTL,0.12 ID X 0.26"OD,STL	78189	1204-00-00-0541C
-94	129-0299-00			2	.					POST,ELEC-MECH:HEX,0.333 INCH LONG	80009	129-0299-00
-95	210-0004-00			2	.					WASHER,LOCK:INTL,0.12 ID X 0.26"OD,STL	78189	1204-00-00-0541C
										- - - * - - -		
-96	-----	XB030000		1	.					CKT BOARD ASSY:ATTENUATOR(SEE A1 EPL)		
-97	131-1030-00			10	.					CONTACT ASSY,EL:CAM SWITCH,BOTTOM	80009	131-1030-00
	131-1031-00			10	.					CONTACT ASSY,EL:CAM SWITCH,TOP (ATTACHING PARTS)	80009	131-1031-00
	210-0779-00			1	.					RIVET,TUBULAR:0.051 OD X 0.115 INCH LONG	42838	RA-29952715
										- - - * - - -		
-98	136-0252-01			8	.					CONTACT,ELEC:0.178 INCH LONG	00779	1-332095-2
	136-0333-00			2	.					SOCKET,PIN TERM:0.138 INCH LONG	00779	1-331677-4
	337-1406-00			1	.					SHLD,ELECTRICAL:CAM CONTACTS (ATTACHING PARTS)	80009	337-1406-00
-99	211-0001-00			3	.					SCREW,MACHINE:2-56 X 0.25 INCH,PNH STL	83385	OBD
	210-0053-00			3	.					WASHER,LOCK:INTL,0.092 ID X 0.175"OD,STL	83385	OBD
-100	210-1134-00			3	.					WASHER,FLAT:0.09 ID X 0.25 INCH OD,BRS	12327	OBD
										- - - * - - -		
	337-1406-00			1	.					SHLD,ELECTRICAL:CAM CONTACTS	80009	337-1406-00
-101	441-0992-00 ¹	B010100	B029999	1	.					CHAS,PLUG-IN UN:		
	441-0992-04 ¹	B030000		1	.					CHAS,PL-IN UNIT:ATTENUATOR	80009	441-0992-04
	441-0992-00 ²	B010100	B019999	1	.					CHAS,PLUG-IN UN:		
	441-0992-04 ²	B020000		1	.					CHAS,PL-IN UNIT:ATTENUATOR	80009	441-0992-04
-102	175-0832-00			FT	WIRE					ELECTRICAL:9 WIRE RIBBON	08261	OBD
	175-0832-00			FT	WIRE					ELECTRICAL:9 WIRE RIBBON	08261	OBD
-103	175-0826-00			FT	WIRE					ELECTRICAL:3 WIRE RIBBON	80009	175-0826-00

¹7A15A only.
²7A15AN only.

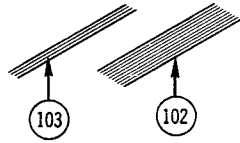

Black reference numbers denote parts which are not common to both instruments.

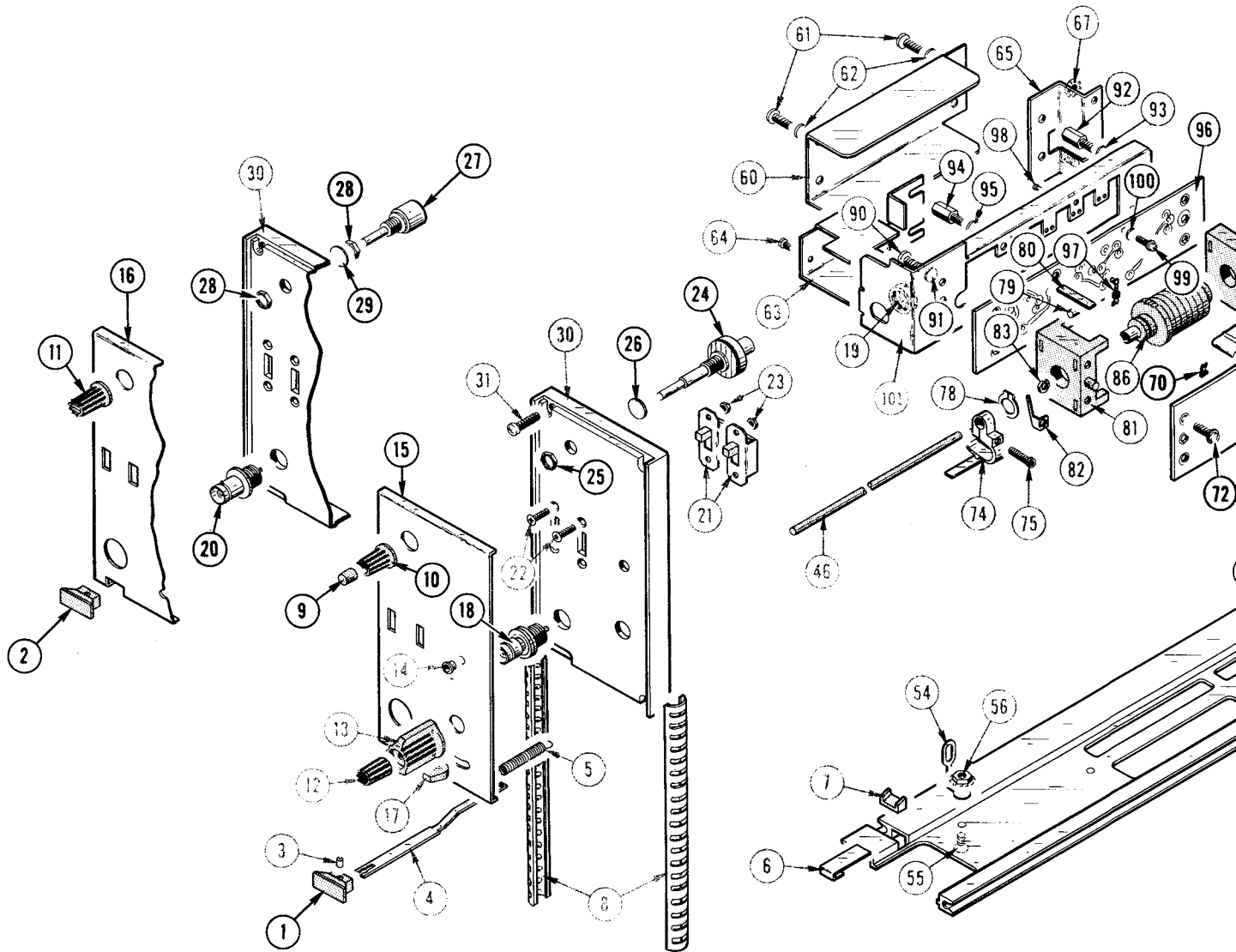
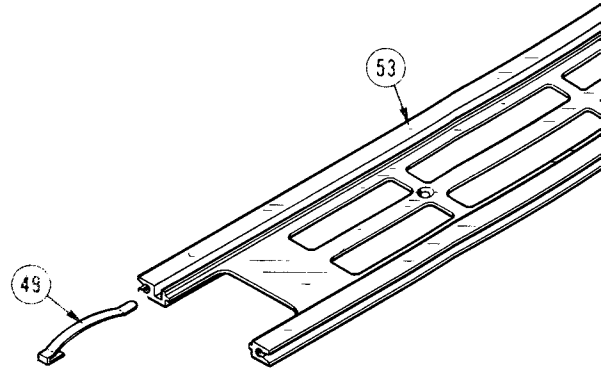

+

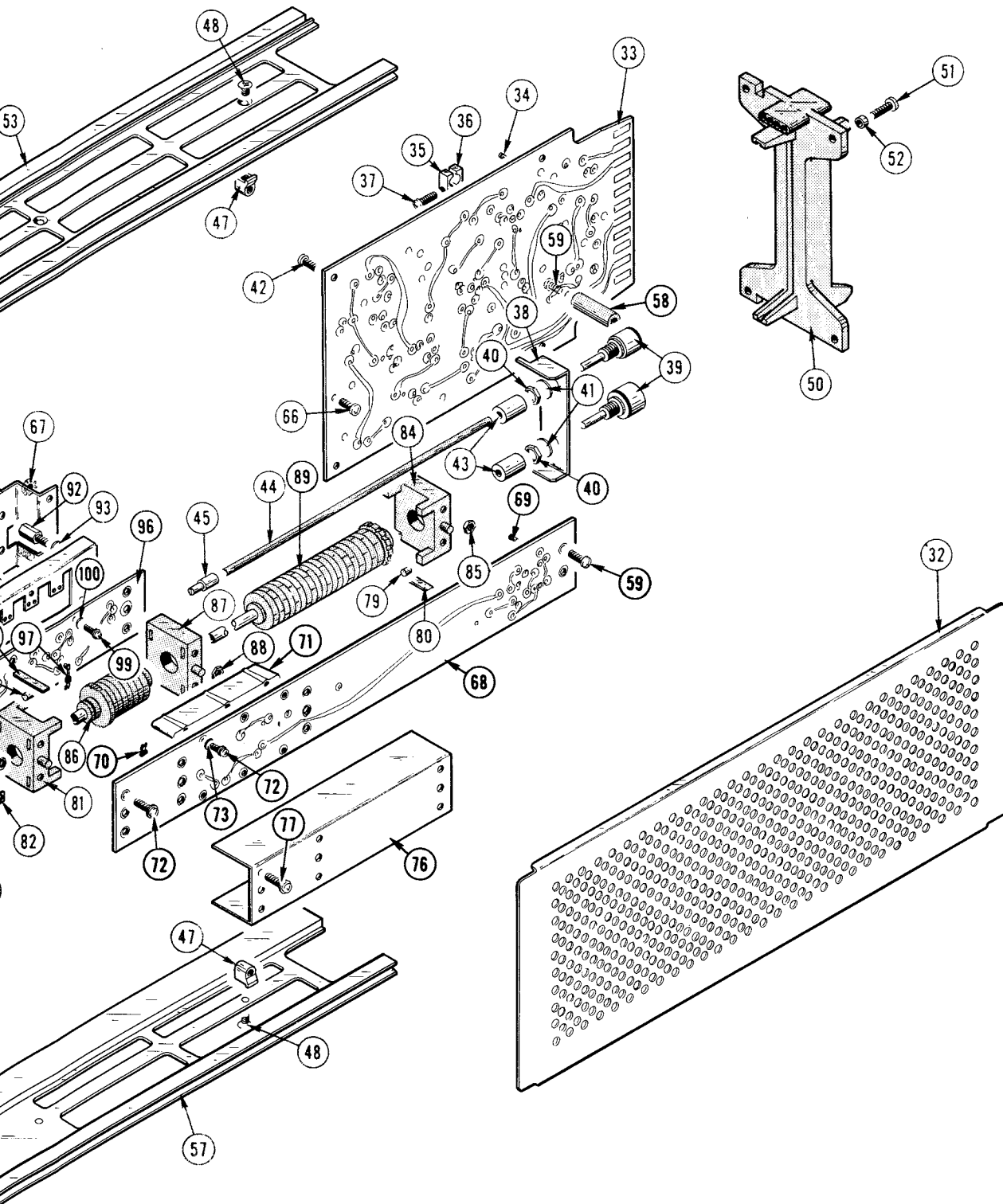

7A15A/7A15AN AMPLIFIERS

+

STANDARD ACCESSORIES

Fig. & Index No.	Tektronix Part No.	Serial/Model No.		Q t y	1 2 3 4 5					Description	
		Eff	Disc								
2-	070-1210-00			1							MANUAL, instruction (not shown)

CARTON ASSEMBLY
(Part No. 065-0125-00)

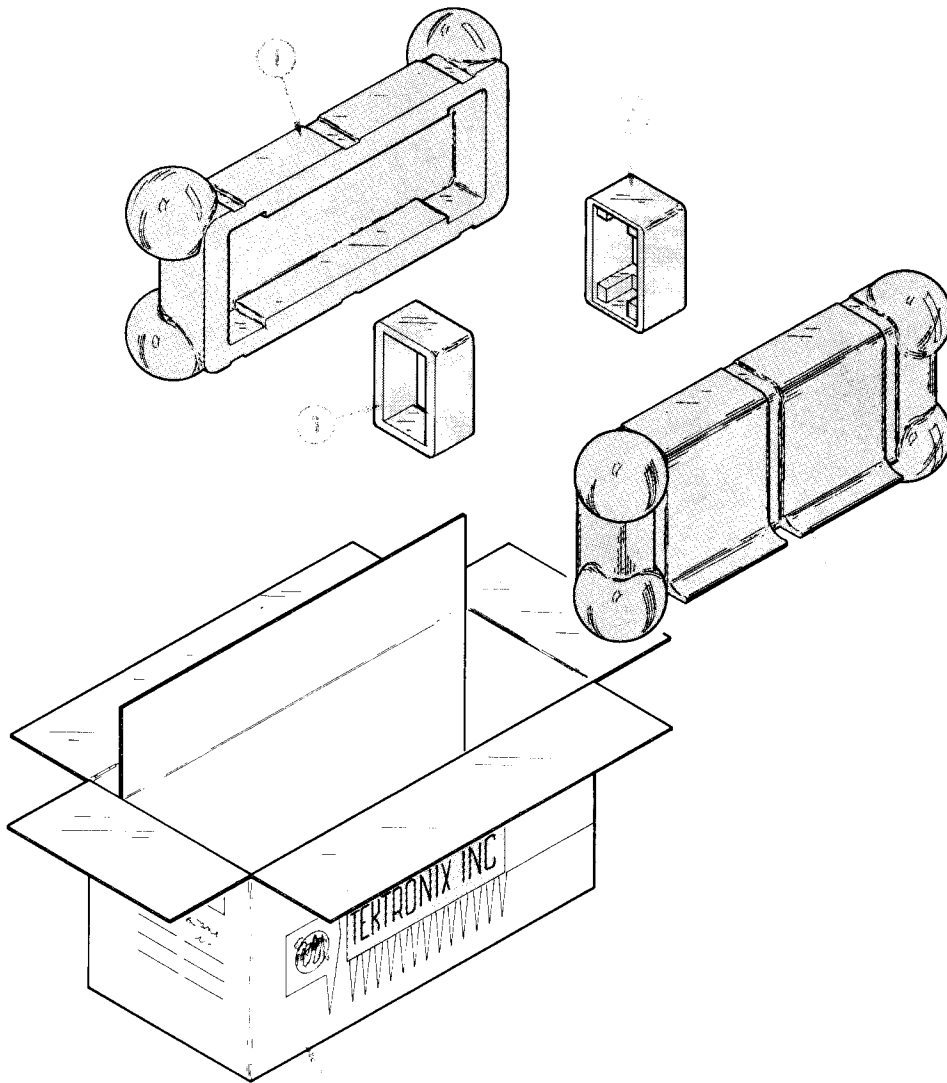

Fig. & Index No.	Tektronix Part No.	Serial/Model No.		Q t y	1	2	3	4	5	Description
		Eff	Disc							
2-	065-0125-00			1						CARTON ASSEMBLY
-1	004-0241-00			-						Carton assembly includes:
-2	004-0242-00			2						CASE HALF
-3	004-0243-00			1						END CAP, rear
-4	004-0748-00			1						END CAP, front
				1						CARTON

MANUAL CHANGE INFORMATION

At Tektronix, we continually strive to keep up with latest electronic developments by adding circuit and component improvements to our instruments as soon as they are developed and tested.

Sometimes, due to printing and shipping requirements, we can't get these changes immediately into printed manuals. Hence, your manual may contain new change information on following pages.

A single change may affect several sections. Since the change information sheets are carried in the manual until all changes are permanently entered, some duplication may occur. If no such change pages appear following this page, your manual is correct as printed.

SERVICE NOTE

Because of the universal parts procurement problem, some electrical parts in your instrument may be different from those described in the Replaceable Electrical Parts List. The parts used will in no way alter or compromise the performance or reliability of this instrument. They are installed when necessary to ensure prompt delivery to the customer. Order replacement parts from the Replaceable Electrical Parts List.

CALIBRATION TEST EQUIPMENT REPLACEMENT

Calibration Test Equipment Chart

This chart compares TM 500 product performance to that of older Tektronix equipment. Only those characteristics where significant specification differences occur, are listed. In some cases the new instrument may not be a total functional replacement. Additional support instrumentation may be needed or a change in calibration procedure may be necessary.

Comparison of Main Characteristics

DM 501 replaces 7D13		
PG 501 replaces 107	PG 501 - Risetime less than 3.5 ns into 50 Ω .	107 - Risetime less than 3.0 ns into 50 Ω .
108	PG 501 - 5 V output pulse; 3.5 ns Risetime.	108 - 10 V output pulse; 1 ns Risetime.
111	PG 501 - Risetime less than 3.5 ns; 8 ns Pretrigger pulse delay.	111 - Risetime 0.5 ns; 30 to 250 ns Pretrigger Pulse delay.
114	PG 501 - ± 5 V output.	114 - ± 10 V output. Short proof output.
115	PG 501 - Does not have Paired, Burst, Gated, or Delayed pulse mode; ± 5 V dc Offset. Has ± 5 V output.	115 - Paired, Burst, Gated, and Delayed pulse mode; ± 10 V output. Short-proof output.
PG 502 replaces 107	PG 502 - 5 V output	108 - 10 V output.
108	PG 502 - Risetime less than 1 ns; 10 ns Pretrigger pulse delay.	111 - Risetime 0.5 ns; 30 to 250 ns Pretrigger pulse delay.
111	PG 502 - ± 5 V output	114 - ± 10 V output. Short proof output.
114	PG 502 - Does not have Paired, Burst, Gated, Delayed & Undelayed pulse mode; Has ± 5 V output.	115 - Paired, Burst, Gated, Delayed & Undelayed pulse mode; ± 10 V output. Short-proof output.
115	PG 502 - Does not have Paired or Delayed pulse. Has ± 5 V output.	2101 - Paired and Delayed pulse; 10 V output.
2101		
PG 506 replaces 106	PG 506 - Positive-going trigger output signal at least 1 V; High Amplitude output, 60 V.	106 - Positive and Negative-going trigger output signal, 50 ns and 1 V; High Amplitude output, 100 V.
067-0502-01	PG 506 - Does not have chopped feature.	0502-01 - Comparator output can be alternately chopped to a reference voltage.
SG 503 replaces 190, 190A, 190B	SG 503 - Amplitude range 5 mV to 5.5 V p-p.	190B - Amplitude range 40 mV to 10 V p-p.
191	SG 503 - Frequency range 250 kHz to 250 MHz.	191 - Frequency range 350 kHz to 100 MHz.
067-0532-01	SG 503 - Frequency range 250 kHz to 250 MHz.	0532-01 - Frequency range 65 MHz to 500 MHz.
TG 501 replaces 180, 180A	TG 501 - Marker outputs, 5 sec to 1 ns. Sinewave available at 5, 2, and 1 ns. Trigger output - slaved to marker output from 5 sec through 100 ns. One time-mark can be generated at a time.	180A - Marker outputs, 5 sec to 1 μ s. Sinewave available at 20, 10, and 2 ns. Trigger pulses 1, 10, 100 Hz; 1, 10, and 100 kHz. Multiple time-marks can be generated simultaneously.
181	TG 501 - Marker outputs, 5 sec to 1 ns. Sinewave available at 5, 2, and 1 ns.	181 - Marker outputs, 1, 10, 100, 1000, and 10,000 μ s, plus 10 ns sinewave.
184	TG 501 - Marker outputs, 5 sec to 1 ns. Sinewave available at 5, 2, and 1 ns. Trigger output - slaved to marker output from 5 sec through 100 ns. One time-mark can be generated at a time.	184 - Marker outputs, 5 sec to 2 ns. Sinewave available at 50, 20, 10, 5, and 2 ns. Separate trigger pulses of 1 and .1 sec; 10, 1, and .1 ms; 10 and 1 μ s. Marker amplifier provides positive or negative time marks of 25 V min. Marker intervals of 1 and .1 sec; 10, 1, and .1 ms; 10 and 1 μ s.
2901	TG 501 - Marker outputs, 5 sec to 1 ns. Sinewave available at 5, 2, and 1 ns. Trigger output - slaved to marker output from 5 sec through 100 ns. One time-mark can be generated at a time.	2901 - Marker outputs, 5 sec to 0.1 μ s. Sinewave available to 50, 10, and 5 ns. Separate trigger pulses, from 5 sec to 0.1 μ s. Multiple time-marks can be generated simultaneously.

NOTE: All TM 500 generator outputs are short-proof. All TM 500 plug-in instruments require TM 500-Series Power Module.

Scans By *Artek Media*

Artek Media
1042 Plummer Cir. SW
Rochester, MN 55902

www.artekmedia.com

“High resolution scans of obsolete technical manuals”

If your looking for a quality scanned technical manual in PDF format please visit our WEB site at www.artekmedia.com or drop us an email at manuals@artekmedia.com and we will be happy to email you a current list of the manuals we have available.

If you don't see the manual you need on the list drop us a line anyway we may still be able to point you to other sources. If you have an existing manual you would like scanned please write for details, This can often be done very reasonably in consideration for adding your manual to our library.

Typically the scans in our manuals are done as follows;

- 1) Typed text pages are typically scanned in black and white at 300 dpi.
- 2) Photo pages are typically scanned in gray scale mode at 600 dpi
- 3) Schematic diagram pages are typically scanned in black and white at 600 dpi unless the original manual had colored high lighting (as is the case for some 70's vintage Tektronix manuals).

If you purchased this manual from us (typically through our Ebay name of ArtekMedia) thank you very much. If you received this from a well-meaning “friend” for free we would appreciate your treating this much like you would “share ware”. By that we mean a donation of at least \$5-10 per manual is appreciated in recognition of the time (a manual can take as much as 40 hours to reproduce, book, link etc.), energy and quality of effort that went into preserving this manual. Donations via PayPal go to: manuals@artekmedia.com or can be mailed to us the address above.

Thanks



Dave & Lynn Henderson
Artek Media