

INSTRUCTION MANUAL

7A16A AMPLIFIER

Serial Number _____

Scans By *Artek Media*

Artek Media
1042 Plummer Cir. SW
Rochester, MN 55902

www.artekmedia.com

"High resolution scans of obsolete technical manuals"

If your looking for a quality scanned technical manual in PDF format please visit our WEB site at www.artekmedia.com or drop us an email at manuals@artekmedia.com and we will be happy to email you a current list of the manuals we have available.

If you don't see the manual you need on the list drop us a line anyway we may still be able to point you to other sources. If you have an existing manual you would like scanned please write for details, This can often be done very reasonably in consideration for adding your manual to our library.

Typically the scans in our manuals are done as follows;

- 1) Typed text pages are typically scanned in black and white at 300 dpi.
- 2) Photo pages are typically scanned in gray scale mode at 600 dpi
- 3) Schematic diagram pages are typically scanned in black and white at 600 dpi unless the original manual had colored high lighting (as is the case for some 70's vintage Tektronix manuals).

If you purchased this manual from us (typically through our Ebay name of ArtekMedia) thank you very much. If you received this from a well-meaning "friend" for free we would appreciate your treating this much like you would "share ware". By that we mean a donation of at least \$5-10 per manual is appreciated in recognition of the time (a manual can take as much as 40 hours to reproduce, book, link etc.), energy and quality of effort that went into preserving this manual. Donations via PayPal go to: manuals@artekmedia.com or can be mailed to us the address above.

Thanks



Dave & Lynn Henderson
Artek Media



WARRANTY

All TEKTRONIX instruments are warranted against defective materials and workmanship for one year. Any questions with respect to the warranty should be taken up with your TEKTRONIX Field Engineer or representative.

All requests for repairs and replacement parts should be directed to the TEKTRONIX Field Office or representative in your area. This will assure you the fastest possible service. Please include the instrument Type Number or Part Number and Serial Number with all requests for parts or service.

Specifications and price change privileges reserved.

Copyright © 1972 by Tektronix, Inc., Beaverton, Oregon. Printed in the United States of America. All rights reserved. Contents of this publication may not be reproduced in any form without permission of Tektronix, Inc.

U.S.A. and foreign TEKTRONIX products covered by U.S. and foreign patents and/or patents pending.

TEKTRONIX is a registered trademark of Tektronix, Inc.

TABLE OF CONTENTS

	Page
SECTION 1	SPECIFICATION
	Introduction 1-1
	Electrical Characteristics 1-1
	Environmental Characteristics 1-2
	Physical Characteristics 1-2
SECTION 2	OPERATING INSTRUCTIONS
	Installation 2-1
	Function of Controls and Connectors 2-1
	Basic Operation 2-2
	General Operating Information 2-2
	Applications 2-3
SECTION 3	CIRCUIT DESCRIPTION
	Block Diagram Description 3-1
	Detailed Circuit Description 3-1
SECTION 4	MAINTENANCE
	Preventive Maintenance 4-1
	Troubleshooting 4-1
	Corrective Maintenance 4-3
SECTION 5	CALIBRATION
	Performance Check 5-1
	Test Equipment Required 5-1
	Short Form Procedure 5-2
	Calibration Procedure 5-3
	Balance 5-4
	Gain 5-4
	Compensation 5-5
	Bandwidth and Risetime 5-6
SECTION 6	ELECTRICAL PARTS LIST
	Abbreviations and Symbols
	Parts Ordering Information
SECTION 7	DIAGRAMS AND CIRCUIT BOARD ILLUSTRATIONS
	Symbols and Reference Designators
SECTION 8	MECHANICAL PARTS LIST
	Mechanical Parts List Information
	Index of Mechanical Parts Illustrations
	Mechanical Parts List

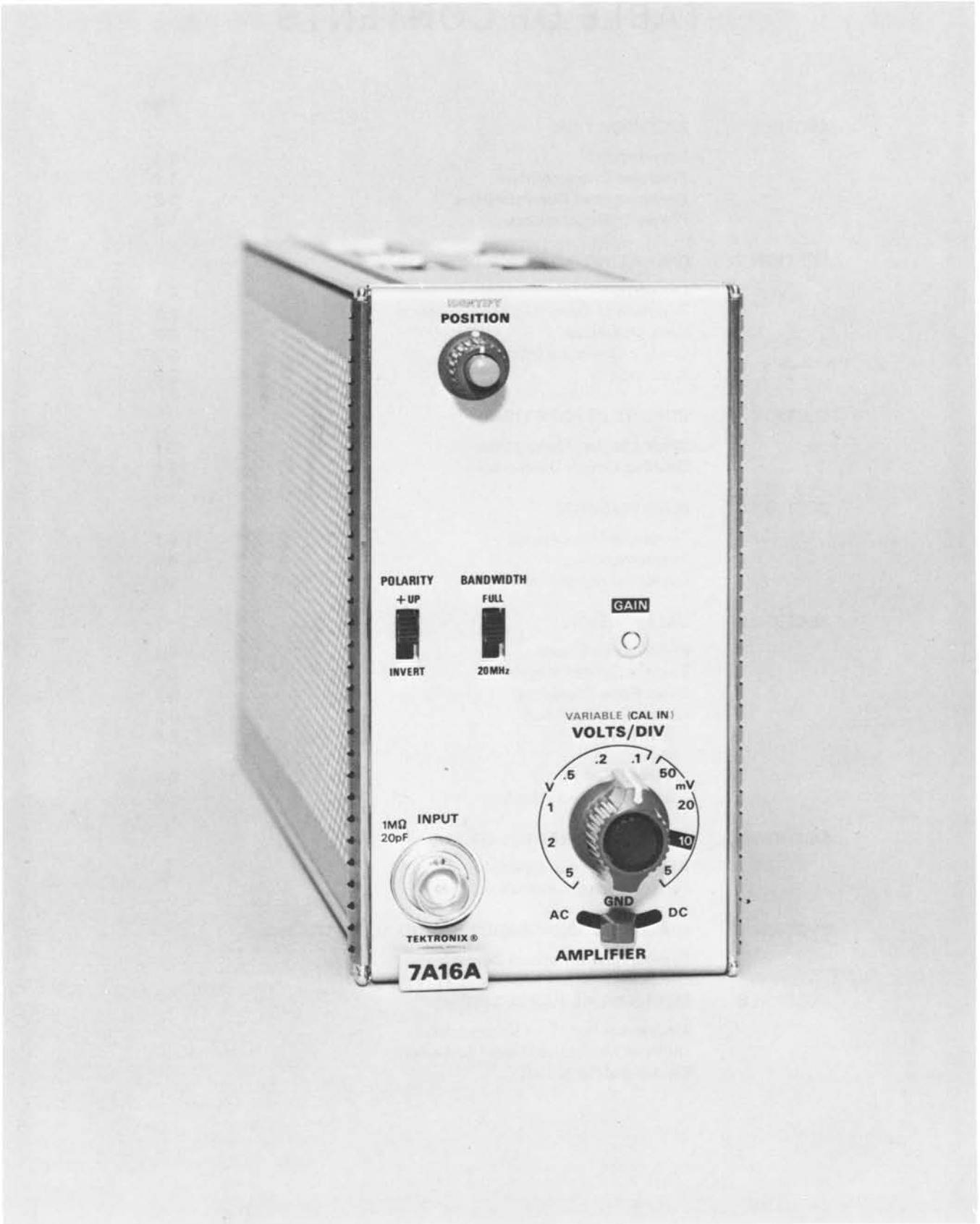

Fig. 1-1. 7A16A Amplifier Plug-in.

SPECIFICATION

Introduction

The 7A16A Amplifier Plug-In Unit is a wide-bandwidth amplifier designed for use with TEKTRONIX 7000-Series

Oscilloscopes. The 7A16A can be operated in any plug-in compartment of 7000-Series Oscilloscopes. Readout encoding and trace identify functions are provided to readout equipped oscilloscopes.

TABLE 1-1
ELECTRICAL

Characteristics	Performance Requirements		Supplemental Information
Deflection Factor			
Calibrated Range	5 mV/div to 5 V/div, 10 steps in a 1-2-5 sequence.		
Accuracy	Within 2% of indicated deflection factor with GAIN adjusted at 10 mV/div.		
Uncalibrated (VARIABLE)	Continuously variable between calibrated steps; extends deflection factor to at least 12.5 V/div.		
Gain Range			Permits adjustment of deflection factor for calibrated operation with all 7000-Series main-frames.
Frequency Response			
Bandwidth	With 7400-Series 60 MHz	With 7500-Series 90 MHz	
	With 7700-Series 150 MHz	With 7900-Series 225 MHz	
AC Coupled (Lower Bandwidth Limit)	10 Hz or less.		
20 MHz Bandwidth			20 MHz, ± 3 MHz.
Step Response			
Risetime	With 7400-Series 5.9 ns	With 7500-Series 3.9 ns	
	With 7700-Series 2.4 ns	With 7900-Series 1.6 ns	
20 MHz Bandwidth Risetime			21 ns maximum.
Maximum Input Voltage			
DC Coupled			250 V (DC + peak AC); A component 500 V P-P maximum, 1 kHz or less.
AC Coupled			500 V (DC + peak AC); A component 500 V P-P maximum, 1 kHz or less.

TABLE 1-1 (cont)

Characteristics	Performance Requirements	Supplemental Information
Input R and C		
Resistance		1 MΩ ±2%.
Capacitance		20 pF ±0.5 pF.
Overdrive Recovery Time		0.1 ms or less to recover to within one division after removal of overdrive signal of up to +75 div or -75 div regardless of overdrive signal duration.
DC Drift		
Drift with Time (Ambient Temp and Line Voltage Constant)		0.02 div or less in any one minute after one hour warmup.
Drift with Temperature (Line Voltage Constant)		Not more than 0.02 div/°C.

TABLE 1-2

ENVIRONMENTAL CHARACTERISTICS

Refer to the specifications for the associated oscilloscope.
--

TABLE 1-3

PHYSICAL

Size	Fits all 7000-Series plug-in compartments.
Weight	0.9 kg or 1.9 lbs.

OPERATING INSTRUCTIONS

General

To effectively use the 7A16A, the operation and capabilities of the instrument must be known. This section describes front-panel control functions, general information on signal input connections, and other subjects that pertain to various measurement applications.

Installation

The 7A16A is calibrated and ready for use as received. It can be installed in any compartment of TEKTRONIX 7000-Series Oscilloscopes, but is intended for use primarily in vertical plug-in compartments. To install, align the upper and lower rails of the 7A16A with the oscilloscope tracks and insert the plug-in. The front panel will be flush with the front of the oscilloscope when the plug-in is inserted, and the latch at the bottom-left corner will be in place against the front panel.

To remove the 7A16A, pull on the latch (which is inscribed with the unit identification "7A16A") and the plug-in will unlatch. Continue pulling on the latch to slide the 7A16A out of the oscilloscope.

Functions of Controls and Connectors

Front Panel

INPUT Connector

Provides signal connection to the amplifier.

AC-GND-DC Switch

Selects signal input coupling mode.

AC: The AC component of the signal is coupled to the input while the DC component is blocked.

DC: Both AC and DC components of the signal is coupled to the amplifier input.

GND: Grounds the amplifier input while maintaining the same load at the INPUT connector. Provides a path for pre-charging the AC coupling capacitor (this feature protects both the 7A16A and the source generator from possible over-voltage conditions).

POSITION

Controls position of the trace.

IDENTIFY Pushbutton

Deflects trace about 0.3 division for trace identification. In instruments with readout, also replaces readout with the word "IDENTIFY".

VOLTS/DIV Switch

Selects calibrated deflection factors from 5 mV/div to 5 V/div; 10 steps in a 1-2-5 sequence.

VARIABLE (VOLTS/DIV)

Provides continuously variable uncalibrated settings between calibrated steps. Extends the deflection factor to 12.5 volts/division or more.

GAIN Adjustment

Screwdriver adjustment permits calibration of deflection factor.

POLARITY Switch

Provides a means of inverting the display.

+UP: A positive-going signal at the INPUT connector deflects the CRT display upward.

INVERT: A positive-going signal at the INPUT connector deflects the CRT display downward.

BANDWIDTH Switch

Provides a means of limiting the upper bandwidth.

FULL: Allows the 7A16A to operate at full rated bandwidth.

20 MHz: Reduces the upper bandwidth of the 7A16A to about 20 MHz.

BASIC OPERATION

General. This procedure demonstrates the use of the connectors and controls of the 7A16A, while at the same time providing a means of checking the basic operation of the instrument.

Preliminary Setup. Install the 7A16A into any 7000-series oscilloscope vertical compartment and set the oscilloscope VERTICAL MODE and TRIGGER SOURCE to the proper settings.

Install a 7-series time-base unit into a horizontal compartment and set the oscilloscope HORIZONTAL MODE to the proper setting. Set the time-base unit to a sweep rate of one-millisecond per division and set the triggering mode to AUTO.

Procedure

1. Set the 7A16A AC-GND-DC switch to GND and position the trace to the center of the graticule.

2. Set the VOLTS/DIV switch to 10 mV and apply a 40 mV 1 kHz square-wave signal from the oscilloscope CALIBRATOR to the 7A16A INPUT connector. Set the AC-GND-DC switch to DC and check for a four-division display.

3. Set POLARITY switch to INVERT and check that the displayed signal is inverted as compared to its appearance in step 2.

4. Set the AC-GND-DC switch to AC and check that the trace is centered on the CRT graticule.

GENERAL OPERATING INFORMATION

Signal Connections

In general, probes offer the most convenient means of connecting a signal to the input of the 7A16A. A 10X attenuator probe offers a high impedance and allows the circuit under test to perform very close to normal operating conditions.

The TEKTRONIX P6053 probe is equipped with a readout coding ring which connects to a circuit in the amplifier unit. This automatically corrects the readout displayed on the CRT to the actual deflection factor at the tip of the probe. This probe is recommended for use with the 7A16A and an oscilloscope equipped with readout. The TEKTRONIX P6054 probe is electrically identical to the P6053 but is intended for use with systems not equipped with readout. For more information refer to the Tektronix, Inc. catalog.

Vertical Gain Check and Adjustment

To check the gain of the 7A16A, set the VOLTS/DIV switch to 10 mV and connect a 40 mV, 1 kHz signal from the oscilloscope calibrator to the Input connector. The vertical deflection should be exactly four divisions. If not, adjust the front panel GAIN for exactly four divisions.

Input Coupling

The AC-GND-DC switch allows a choice of input coupling methods. The type of display desired and the applied signal will determine the coupling to use.

The DC coupling position can be used for most applications. For AC signals with frequencies below about 30 Hz (10 Hz with a 10X probe), and square waves whose low-frequency components are important to the display, it is necessary to use DC coupling to obtain a satisfactory presentation.

In the AC coupling position the DC component of the signal is blocked by a capacitor in the input circuit. The AC coupling position provides the best display of signals with a DC component much larger than the AC component. The pre-charge feature should be used when there is a possibility of having a residual charge on the input capacitor of the opposite polarity to the intended input, and when the algebraic sum of the combination of charges may be greater than the maximum input limitations of the amplifier. To use this feature, first set the coupling switch to GND, then connect the probe to the circuit and wait about two seconds for the coupling capacitor to charge, set the coupling switch to AC.

The GND position provides a ground reference at the input of the amplifier without externally grounding the Input connectors. However, the signals connected to the inputs are not grounded, and the same DC load is presented to the signal source.

VOLTS/DIV and VARIABLE

The amount of deflection produced by a signal is determined by the signal amplitude, the attenuation factor of the probe, the setting of the VOLTS/DIV switch, and the setting of the VARIABLE Control. Calibrated deflection factors represented by the setting of the VOLTS/DIV switch apply only when the VARIABLE control is in the CAL position (pushed-in).

The VARIABLE control provides variable uncalibrated settings between the calibrated steps of the VOLTS/DIV switch. With the VARIABLE control out set fully counter-clockwise the uncalibrated deflection factor is extended to at least 2.5 times the attenuator setting. By applying a calibrated voltage source to the INPUT connector, any specific deflection factor can be set within the range of the VARIABLE control.

Polarity Switch

The POLARITY switch provides a means of inverting the displayed signal. With the POLARITY set to +UP, a positive-going signal at the INPUT produces an upward deflection of the CRT display. With the POLARITY set to INVERT, a positive-going signal will produce a downward deflection of the CRT display.

Trace Identification

When the IDENTIFY button is pressed, the trace is deflected upward about 0.3 division to identify the 7A16A trace. This feature is particularly useful when multiple traces are displayed on the CRT. In mainframes with readout, it also replaces the deflection factor readout with the word "IDENTIFY".

APPLICATIONS

General

The following information describes the procedures and techniques for making measurements with a 7A16A and the associated TEKTRONIX oscilloscope and time-base. These applications are not described in detail, since each application must be adapted to the requirements of the individual measurements. This instrument can also be used for many applications which are not described in this manual. Contact your local TEKTRONIX Field Office or representative for assistance in making specific measurements with this instrument.

Peak-to-Peak Voltage Measurements (AC)

To make peak-to-peak voltage measurements, use the following procedure:

1. Apply the signal to the Input connector.

2. Set the Coupling switch to AC.

NOTE

For low-frequency signals below about 30 hertz, use the DC position to prevent attenuation of the signal.

3. Set the VOLTS/DIV switch to display about five vertical divisions of the waveform.

4. Set the time-base Triggering controls for a stable display. Set the Time Base to a sweep rate which displays several cycles of the waveform.

5. Turn the 7A16A POSITION control so the lower portion of the waveform coincides with one of the graticule lines below the center horizontal line, and the top of the waveform is within the viewing area. With the time base Position control, move the display so one of the upper peaks lies near the center vertical line (see Fig. 2-1).

6. Measure the divisions of vertical deflection peak to peak. Check that the VARIABLE control is in the CAL position.

NOTE

This technique can also be used to make measurements between two points on the waveform, rather than peak to peak.

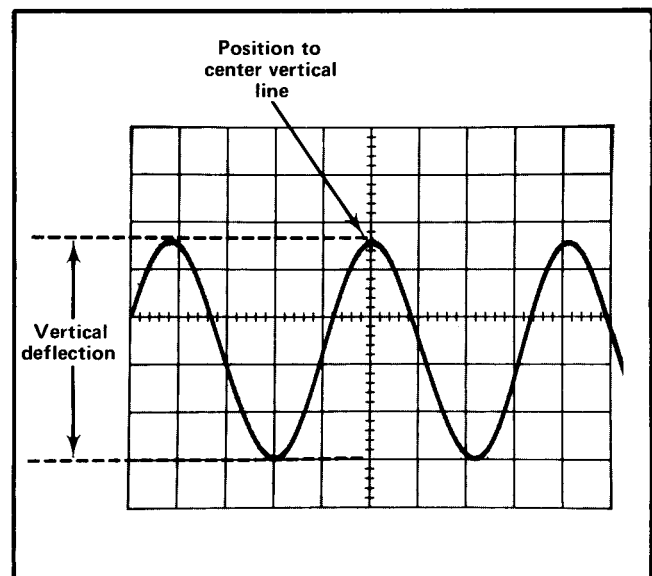

Fig. 2-1. Measuring the peak-to-peak voltage of a waveform.

Operation—7A16A

7. Multiply the distance measured in step 7 by the VOLTS/DIV switch setting. Include the attenuation factor of the probe if used.

EXAMPLE: Assume that the peak to peak vertical deflection is 4.5 divisions using a 10X attenuator probe, and the VOLTS/DIV switch is set to 1 V.

$$\text{Volts} = \frac{\text{vertical deflection (divisions)}}{\text{VOLTS/DIV setting}} \times \text{probe attenuation factor}$$

Substituting the given values:

$$\text{Volts Peak to Peak} = 4.5 \times 1 \times 10$$

The peak-to-peak voltage is 45 volts.

If you are using a 7A16A with a coded probe and an oscilloscope equipped with readout, simply multiply the distance measured in step 7 by the deflection factor displayed on the CRT.

Instantaneous Voltage Measurements(DC)

To measure the DC level at a given point on a waveform, proceed as follows:

1. Connect the signal to the Input connector.
2. Set the VOLTS/DIV switch to display about five divisions.
3. Set the Coupling switch to GND and position the trace to the bottom graticule line or other reference line. If the voltage is negative with respect to ground, position the trace to the top graticule line. Do not move the POSITION control after this reference line has been established.

NOTE

To measure a voltage level with respect to another voltage rather than ground, make the following changes to Step 4. Set the Coupling switch to DC and apply the reference voltage to the Input connector. Then position the trace to the reference line and disconnect the reference voltage.

4. Set the Coupling switch to DC. The ground reference line can be checked at any time by switching to the GND position.

5. Set the time-base Triggering controls for a stable display. Set the Time Base sweep rate for an optimum display of the waveform.

6. Measure the distance in divisions between the reference line and the point on the waveform at which the DC level is to be measured. For example, in Fig. 2-2 the measurement is between the reference line and point A.

7. Establish the polarity of the waveform. With the +UP/INV switch in the +UP position, any point above the reference line is positive.

8. Multiply the distance measured in step 7 by the VOLTS/DIV switch setting. Include the attenuation factor of the probe, if used.

EXAMPLE: Assume the vertical distance measured is 4.6 divisions (see Fig. 2-2) and the waveform is above the reference line using a 10X probe with a VOLTS/DIV switch setting of 0.5 V.

Using the formula:

$$\text{Instantaneous Voltage} = \frac{\text{vertical distance (divisions)}}{\text{VOLTS/DIV setting}} \times \text{polarity} \times \text{probe attenuation factor}$$

Substituting the given values:

$$\text{Instantaneous Voltage} = 4.6 \times 1 \times 0.5 \text{ V} \times 10$$

The instantaneous voltage is 23 volts.

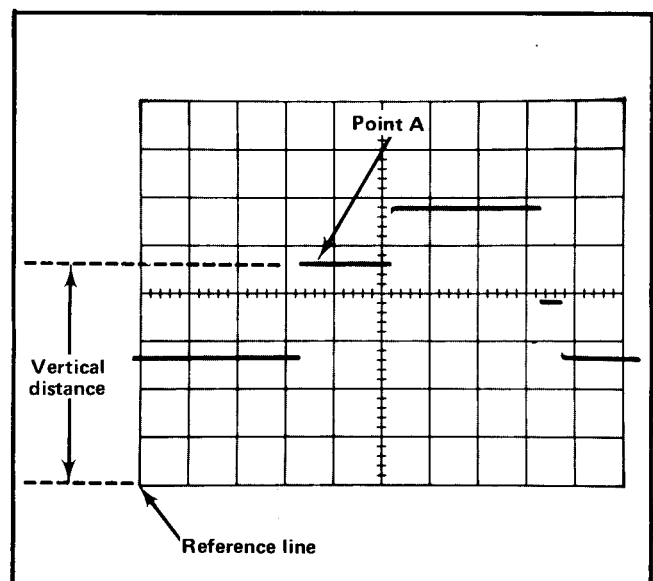

Fig. 2-2. Measuring instantaneous voltage with respect to same reference.

Comparison Measurements

In some applications it may be desirable to establish units of measurement other than those indicated by the VOLTS/DIV switch. This is particularly useful when comparing unknown signals to a reference amplitude. One use for the comparison-measurement technique is to facilitate calibration of equipment where the desired amplitude does not produce an exact number of divisions of deflection. The adjustment will be easier and more accurate if arbitrary units of measurement are established, so that the correct adjustment is indicated by an exact number of divisions of deflection. The following procedure describes how to establish arbitrary units of measure for comparison measurements.

To establish a vertical deflection factor based upon a specific reference amplitude, proceed as follows:

1. Connect the reference signal to the Input connector. Set the time-base sweep rate to display several cycles of the signal.

2. Set the VOLTS/DIV switch and the VARIABLE control to produce a display which is an exact number of vertical divisions in amplitude. Do not change the VARIABLE control after obtaining the desired deflection.

3. To establish an arbitrary vertical deflection factor so the amplitude of an unknown signal can be measured accurately at any setting of the VOLTS/DIV switch, the amplitude of the reference signal must be known. If it is not known, it can be measured before the VARIABLE control is set in step 2.

4. Divide the amplitude of the reference signal (volts) by the product of the vertical deflection (divisions) established in step 2 and the setting of the VOLTS/DIV switch.

This is the vertical conversion factor.

$$\text{Vertical Conversion Factor} = \frac{\text{reference signal amplitude (volts)}}{\text{vertical deflection (divisions)} \times \text{VOLTS/DIV setting}}$$

5. To measure the amplitude of an unknown signal, disconnect the reference signal and connect the unknown signal to the Input connector. Set the VOLTS/DIV switch to a setting that provides sufficient vertical deflection to make an accurate measurement. Do not re-adjust the VARIABLE control.

6. Measure the vertical deflection in divisions and calculate the amplitude of the unknown signal using the following formula:

$$\text{Signal Amplitude} = \text{VOLTS/DIV setting} \times \text{vertical conversion factor} \times \text{vertical deflection (divisions)}$$

EXAMPLE: Assume a reference signal amplitude of 30 volts, a VOLTS/DIV setting of 5 V and the VARIABLE control adjusted to provide a vertical deflection of four divisions.

Substituting these values in the vertical conversion factor formula (step 4):

$$\text{Vertical Conversion Factor} = \frac{30 \text{ V}}{4 \times 5 \text{ V}} = 1.5$$

Then with a VOLTS/DIV setting of 2 V, the peak to peak amplitude of an unknown signal which produces a vertical deflection of five divisions can be determined by using the signal amplitude formula (step 6):

$$\text{Signal Amplitude} = 2 \text{ V} \times 1.5 \times 5 = 15 \text{ volts}$$

CIRCUIT DESCRIPTION

Introduction

This section of the manual contains a description of the circuitry used in the 7A16A amplifier. The 7A16A description begins with a discussion of the instrument using the block diagram shown in the Diagrams section. Then, each circuit is described in detail using block diagrams to show the interconnections between stages in each major circuit and the relationship of the front-panel controls to the individual stages.

Complete schematics of each circuit are given in the Diagrams section. Refer to these schematics throughout the following circuit description for electrical values and relationship.

BLOCK DIAGRAM

The signal to be displayed on the CRT is applied to the INPUT connector. The signal passes through the input coupling switch, where the appropriate coupling is selected, to the attenuators. The VOLTS/DIV switch selects the correct amount of attenuation and the signal is passed to the Input Source Follower.

The Polarity Amplifier provides a convenient means of inverting the displayed trace. The output of the Polarity Amplifier drives the 2X Gain Amplifier:

With the VOLTS/DIV switch set to the 5 mV and 10 mV positions, the signal connected to the INPUT connector is passed through the attenuators un-attended. To achieve a deflection factor of 5 mV/Div the gain of the 2X Gain Amplifier is increased from one to two. Internal gain and balance adjustments are included in the amplifier.

Overall GAIN and VARIABLE gain is adjusted in the Gain Amplifier. Variable Balance and high frequency adjustments are also controlled in the Gain Amplifier. The output of the Gain Amplifier is connected to the Positioning circuitry where the POSITION and IDENTIFY functions are controlled.

The Signal Splitter Amplifier provides differential signal outputs for the signal line and the trigger line. This stage contains a bandwidth limiter that limits the upper frequency response to 20 MHz.

The output of the Signal Splitter Amplifier is connected to the oscilloscope mainframe via the interface connector.

Readout encoding circuitry used in the 7A16A is standard to the 7000-Series.

DETAILED CIRCUIT DESCRIPTION

AC-GND-DC Switch

Input signals connected to the INPUT connector can be AC-coupled, DC-coupled, or internally disconnected. S100A is a cam-type switch; a contact-closure chart showing the operation is given on the schematic diagrams. When the AC-GND-DC switch is in the DC position, the INPUT signal is connected directly to the attenuators. In the AC position, the INPUT signal passes through capacitor C10. The capacitor prevents the DC component of the signal from passing to the amplifier. The GND position opens the signal path and connects the input circuit of the amplifier to ground. This provides a ground reference without the need to disconnect the applied signal from the INPUT connector. Resistor R102, connected across the AC-GND-DC switch, allows C10 to be pre-charged in the GND position.

Input Attenuator

The effective overall deflection factor of the 7A16A is determined by the setting of the VOLTS/DIV switch, S100B. The basic deflection factor is 5 millivolts per division of CRT deflection. To increase the basic deflection factor to the values indicated on the front panel, precision attenuators are switched into the circuit. S100B is a cam-type switch and the dots on the contact-closure chart (see Diagram 1) indicate when the associated contacts are in the position shown (open or closed). In the 5 mV/Div and 10 mV/Div positions, the attenuators are not used; the input signal is connected directly to the Source Follower. The 10 mV/Div position decreases the gain of the 2X Gain Amplifier. For switch positions above ten millivolts per division, the attenuators are switched into the circuit singly or in pairs to produce the deflection factor indicated on the front panel. These hybrid attenuators are frequency-compensated voltage dividers. For DC and low-frequency signals, the attenuators are primarily resistance dividers and at high frequencies the attenuator becomes primarily a capacitive divider.

Circuit Description—7A16A

In addition to providing constant attenuation at all frequencies within the bandwidth of the instrument, the input attenuators are designed to maintain the same input RC characteristics (one megohm X 20 pF). Each attenuator contains an adjustable series capacitor to provide correct attenuation at high frequencies, and an adjustable shunt capacitor to provide correct input capacitance.

Input Source Follower

Below SN B080000. Q150A and Q140 form a cascode amplifier with Q150B providing a constant current. R132 limits the current drive to the gate of Q150A. Dual-diode CR130 provides circuit protection by limiting the voltage swing at the gate of Q150A to about ± 14 volts. R134, C130, and the capacitance of R130 provide low frequency compensation. Input capacitance for the 5 mV and 10 mV positions is set by C134. The output to the Polarity Amplifier (U350) is from the source of Q150A and high frequencies from the collector of Q140. R160 is used to balance the input to the Polarity Amplifier.

SN B080000-Up. Q150A is a source follower with Q150B providing a constant current. R132 limits the current drive to the gate of Q150A. Dual-diode CR130 provides circuit protection by limiting the voltage swing at the gate of Q150A to about ± 10 volts. C130, C134, and the capacitance of R130 provide low frequency compensation. Input capacitance for the 5 mV and 10 mV positions is set by C130. The output to the Polarity Amplifier (U350) is from the source of Q150A. C134 and R134 form a negative resistance network for Q150A.

Polarity Amplifier

U350 is a paraphase type amplifier with a dual differential output capability. Polarity of the output is selected by gating the control bases of either the inverted output or the un-inverted output. T301 is a balun transformer and provides differential drive to U350 at high frequencies. C334 and RT334 thermally compensate for gm changes in Q150A.

2X Gain Amplifier

The output of the Polarity Amplifier is connected to a gain switching amplifier, U450. The gain of U450 is set by the control bases, pins 11 and 12. In the 5 mV position, full drive is provided to the following stage from pins 6 and 8. In the 10 mV position, R413 sets the current through the second output pair, pins 5 & 9. This causes the emitter currents to divide equally through R440, R442 and R501, R503. R501, R503 provide the only drive to the following stage, thus forming a 2X gain attenuator. R436 provides low frequency thermal compensation. R453 (2X Bal) is used to balance the emitter currents. CR507 and R507 maintains a constant input voltage while switching between the 5 mV and 10 mV positions.

Gain Amplifier

Integrated circuit U550 is the same type as U350. Both differential outputs of U550 are paralleled to provide drive to the next stage. In the CAL IN position R516 sets the gain for the entire amplifier by adjusting the current at the control bases of U550. In the un-cal position the VARIABLE control, R515, decreases the gain of the entire amplifier up to 2.5 times. RT539 compensates for temperature variations. C531 and R531 are high frequency adjustments. DC balance over the VARIABLE range is adjusted by R553.

Position Circuit

Positioning current is added to the signal current of U550 output from the current sources Q720 and Q730. R736 controls the voltage at the bases of the current sources which in turn determines the amount of positioning current added. When the IDENTIFY switch is closed the current through Q730 is reduced causing the CRT trace to deflect.

Signal Splitter Amplifier

Integrated circuit U750 is the same type as U450. The two differential outputs of U750 are connected to separate common base transistor amplifiers to provide separate display and trigger signals. Both outputs of U750 are biased equally to produce equal signal outputs. R770, C770, and L770 are high frequency compensation adjustments for the display signal. L770 is selected at the factory and need not be changed unless U750, Q860, or Q880 is replaced.

Q820, Q840, Q860, and Q880 are used as level shifters to return the DC level of the display signal to zero. Amplifier Q820-Q840 are switched on when the BANDWIDTH switch is in the full position. With the BANDWIDTH switch in the 20 MHz position Q860-Q880 is switched on. A filter in the collectors of Q860-Q880 limit the bandwidth. CR860 and CR880 isolate the filter from the output when in the FULL mode.

The trigger signal circuitry is similar to the display signal circuitry with Q920 and Q940 as level shifters for the FULL bandwidth position and Q960 and Q980 as level shifters for the 20 MHz bandwidth position.

Connectors

All the connections made to the mainframe by the 7A16A are shown on the connectors portion of Diagram 2. Also shown are the power supply decoupling components.

Readout Encoding

The Readout Encoding circuit consists of switching resistors and probe sensing stage Q620. This circuit encodes the Row and Column output lines for readout of deflection

factor, uncalibrated deflection factor (VARIABLE) information, and signal inversion. Data is encoded on these output lines by switching resistors between them and the time-slot input lines or by current added through Q620.

R647-C647 are switched between time-slot three (TS-3) and the Column output line when the CAL switch is in the un-cal position. This results in the symbol > (greater than) being displayed preceding the deflection factor readout. R648 is switched between TS-2 and the Column output line when the POLARITY switch is in the INVERT position. This results in the symbol ↓ (inverted) being displayed preceding the deflection factor readout.

Switching resistors are used to indicate the setting of the VOLTS/DIV switch to the mainframe readout system. The dots on the contact-closure chart (see Diagram Section) indicate when the associated contacts on the VOLTS/DIV cam switch are closed. R633, R634, and R635 select the number 1, 2, or 5 depending on the combination that is switched in. R638 and R642 select the m (milli) prefix in the 5 mV through 0.5 V (500 mV) positions of the VOLTS/DIV switch. R639 and R643 select the V (volts) symbol in all ranges. R630, R631, and the output of the probe sensing stage (Q620) select the decimal point (number of zeroes), again depending on the resistor combination switched in by the VOLTS/DIV switch.

Probe sensing stage Q620 identifies the attenuation factor of the probe connected to the INPUT connector by sensing the amount of current flowing through the probe coding resistor located in the probe connector. The output of this circuit corrects the mainframe readout system to include the probe attenuation factor. The third contact of the INPUT connector provides the input to the probe sensing device from the probe coding resistance (coded

probes only; see Operating Instructions). The third contact is also used for the IDENTIFY input. The coding resistor forms a voltage divider with R621 through CR621 to the -15 V supply. The resultant voltage sets the bias on Q620 and determines the collector current, along with emitter resistor R622. When the -15 volt time-slot pulse is applied to Interface Connector B33, Q620 is interrogated and its collector current is added to the column current output through Interface Connector A37.

With a 1X probe (or no probe) connected to the INPUT connector, Q620 is turned off. The deflection factor readout is determined by the VOLTS/DIV switch position. With a 10X probe connected, the bias on Q620 allows 100 microamperes of collector current to flow. This increases the deflection factor readout by a factor of 10.

The IDENTIFY button (S45 on Diagram 1) does two things when pressed:

1. It causes the trace representing the 7A16A to move (see the discussion on the Position Circuit).
2. Forward biases CR621 and Q620 to result in a sufficient amount of collector current which replaces the deflection factor readout with the word "IDENTIFY".

These two actions aid in identifying the 7A16A trace when multiple traces are displayed. When the IDENTIFY button is released, the deflection factor readout is restored.

For further information on the operation of the readout system, see the oscilloscope instruction manual.

MAINTENANCE

Introduction

This section of the manual contains maintenance information for use in preventive maintenance, corrective maintenance, and troubleshooting of the 7A16A.

Further maintenance information relating to general maintenance can be found in the instruction manuals for the 7000-series oscilloscopes.

PREVENTIVE MAINTENANCE

General

Preventive maintenance, consisting of cleaning, visual inspection, etc., performed on a regular basis, will improve the reliability of this instrument. Periodic checks of the semiconductor devices used in the unit are not recommended as a preventive maintenance measure. See semiconductor-checking information given under Troubleshooting.

Cleaning



Avoid the use of chemical cleaning agents which might damage the plastics used in this instrument. Special care should be taken when cleaning the Polyphenylene Oxide attenuator board. Do not apply any solvent containing ketones, esters or halogenated hydrocarbons. To clean, use only water soluble detergents, ethyl, methyl or isopropyl alcohol.

Front Panel. Loose dust may be removed with a soft cloth or a dry brush. Water and mild detergent may be used; however, abrasive cleaners should not be used.

Interior. Cleaning the interior of the unit should precede calibration, since the cleaning process could alter the settings of the calibration adjustments. Use low-velocity compressed air to blow off the accumulated dust. Hardened dirt can be removed with a soft, dry brush, cotton-tipped swab, or cloth dampened with a mild detergent and water solution.

Lubrication

Use a cleaning-type lubricant on shaft bushings, interconnecting plug contacts, and switch contacts. Lubricate switch detents with a heavier grease. A lubrication kit containing the necessary lubricating materials and instructions is available through any TEKTRONIX Field Office. Order TEKTRONIX Part Number 003-0342-01.

TROUBLESHOOTING

General

The following is provided to augment information contained in other sections of this manual when troubleshooting the 7A16A. The schematic diagrams, circuit description, and calibration sections should be used to full advantage. The circuit description section gives detailed information on circuit behavior and output requirements.

Troubleshooting Aids

Diagrams. Circuit diagrams are given on foldout pages in Section 7. The circuit number and electrical value of each component in this instrument are shown on the diagrams. Important voltages are also shown.

Circuit Boards. The circuit boards used in the 7A16A are outlined on the schematic diagrams, and photographs of the boards are shown on the backs of the schematic diagrams. Each board-mounted electrical component is identified on the photograph by its circuit number.

Component and Wiring Color Code. Colored stripes or dots on resistors and capacitors signify electrical values, tolerances, etc., according to the EIA standard color code. Components not color coded usually have the value printed on the body.

The insulated wires used for interconnection in the 7A16A are color coded to facilitate tracing wires from one point to another in the unit.

Semiconductor Lead Configuration. The lead configurations of the semiconductor devices used in this instrument are shown on the schematic diagrams.

Troubleshooting Equipment

The following equipment is useful for troubleshooting the 7A16A.

1. **Semiconductor Tester**—Some means of testing the transistors, diodes, and FET's used in this instrument is helpful. A transistor-curve tracer such as the TEKTRONIX Type 576 will give the most complete information.

2. **DC Voltmeter and Ohmmeter**—A voltmeter is required for checking voltages within the circuits, and an ohmmeter for checking resistors and diodes.

3. **Test Oscilloscope**—A test oscilloscope is required to view waveforms at different points in the circuit. A TEKTRONIX 7000-series Oscilloscope equipped with a readout system, 7D13 Digital Multimeter unit, 7B-series Time-Base unit, and a 7A-series Amplifier unit with a 10X probe will meet the needs of both items 2 and 3.

4. **Plug-in Extender**—A fixture that permits operation of the unit outside of the plug-in compartment for better accessibility during troubleshooting. Order TEKTRONIX Part Number 067-0589-00.

Troubleshooting Procedure

This troubleshooting procedure is arranged in an order which checks the simple trouble possibilities before proceeding with extensive troubleshooting.

1. **Check Control Settings.** An incorrect setting of the 7A16A controls can indicate a trouble that does not exist. If there is any question about the correct function or operation of a control or front-panel connector, see the Operating Instructions section.

2. **Check Associated Equipment.** Before proceeding with troubleshooting of the 7A16A check that the equipment used with this instrument is operating correctly. If possible, substitute an amplifier unit known to be operating correctly into the indicator unit and see if the problem persists. Check that the input signals are properly connected and that the interconnecting cables are not defective.

3. **Visual Check.** Visually check the portion of the instrument in which the trouble is suspected. Many troubles can be located by visual indications, such as unsoldered connections, broken wires, damaged circuit boards, damaged components, etc.

4. **Check Instrument Performance.** Check the calibration of the unit or the affected circuit, by performing Performance Check of Section 5. The apparent trouble may only be a result of mis-adjustment, and may be corrected by calibration. Complete calibration instructions are given in Section 5.

5. **Check Voltages.** Often the defective component or stage can be located by checking for the correct voltage in the circuit. Typical voltages are given on the diagrams; however, these are not absolute and may vary slightly between instruments. To obtain operating conditions similar to those used to take these readings, see the instructions in the Diagram section.

6. **Check Individual Components.** The following methods are provided for checking the individual components. Components which are soldered in place are best checked by disconnecting one end to isolate the measurement from the effects of surrounding circuitry.

NOTE

To locate intermittent or temperature sensitive components mounted on the attenuator board, Quik Freeze (Miller Stephenson, MS-240, TEKTRONIX Part Number 006-0173-01) is recommended. Dry ice or dichloro-difluoromethane (Freon 12, Dupont or Can-O-Gas) may also be used. Other types of circuit coolant may damage the polyphenylene oxide boards.

A. **TRANSISTORS.** The best check of transistor operation is actual performance under operating conditions. If a transistor is suspected of being defective, it can best be checked by substituting a component known to be good; however, be sure that circuit conditions are not such that a replacement might also be damaged. If substitute transistors are not available, use a dynamic tester (such as TEKTRONIX Type 576). Static-type testers may be used, but since they do not check operation under simulated operating conditions, some defects may go unnoticed. Be sure the power is off before attempting to remove or replace any transistor.

B. **DIODES.** A diode can be checked for an open or for a short circuit by measuring the resistance between terminals with an ohmmeter set to the R X 1k scale. The diode resistance should be very high in one direction and very low when the meter leads are reversed. Do not check tunnel diodes or back diodes with an ohmmeter.



Do not use an ohmmeter scale that has a high internal current. High currents may damage the diodes.

C. RESISTORS. Check resistors with an ohmmeter. Resistor tolerance is given in the Electrical Parts List. Resistors normally do not need to be replaced unless the measured value varies widely from the specified value.

D. CAPACITORS. A leaky or shorted capacitor can be detected by checking resistance with an ohmmeter on the highest scale. Use an ohmmeter which will not exceed the voltage rating of the capacitor. The resistance reading should be high after initial charge of the capacitor. An open capacitor can best be detected with a capacitance meter, or by checking whether the capacitor passes AC signals.

7. **Repair and Readjust the Circuit.** Special techniques required to replace components in this unit are given under Component Replacement. Be sure to check the performance of any circuit that has been repaired or that has had any electrical components replaced. Recalibration of the affected circuit may be necessary.

CORRECTIVE MAINTENANCE

General

Corrective maintenance consists of component replacement and instrument repair. Special techniques required to replace components in this instrument are given here.

Obtaining Replacement Parts

Standard Parts. All electrical and mechanical part replacements for the 7A16A can be obtained through your local TEKTRONIX Field Office or representative. However, many of the electronic components can be obtained locally in less time than is required to order them from Tektronix, Inc. Before purchasing or ordering replacement parts, check the parts list for value, tolerance, rating and description.

NOTE

When selecting replacement parts, it is important to remember that the physical size and shape of a component may affect the performance of the instrument, particularly at high frequencies. All replacement parts should be direct replacements unless it is known that a different component will not adversely affect instrument performance.

Special Parts. In addition to the standard electronic components, some special parts are used in the 7A16A. These parts are manufactured or selected by Tektronix, Inc. in accordance with our specifications. These special parts are indicated in the parts list by an asterisk preceding the part number. Most of the mechanical parts used in this instrument have been manufactured by Tektronix, Inc.

Order all special parts directly from your local TEKTRONIX Field Office or representative.

Ordering Parts. When ordering replacement parts from Tektronix, Inc., include the following information:

1. Instrument Type.
2. Instrument Serial Number.
3. A description of the part (if electrical, include circuit number).
4. TEKTRONIX Part Number.

Soldering Techniques

WARNING

Disconnect the instrument from the power source before soldering.

Attenuator Circuit Board. The Attenuator Circuit Board is made from polyphenylene oxide because of its excellent electrical characteristics. Use more than normal care when cleaning or soldering this material. The following rules should be observed when removing or replacing parts:

1. Use a low-wattage soldering iron (not over 15 watts).
2. Do not apply more heat, or apply heat for a longer time, than is absolutely necessary.
3. Use some form of vacuum solder remover when removing multi-lead devices.
4. Do not apply any solvent containing ketones, esters or halogenated hydrocarbons.
5. To clean, use only water-soluble detergents, ethyl, methyl or isopropyl alcohol.

Circuit Boards (except Attenuator board). The components mounted on the circuit boards in the amplifier can be replaced using normal circuit board soldering techniques. Keep the following points in mind when soldering on the circuit boards:

1. Use a pencil-type soldering iron with a (wattage) rating from 15 to 50 watts.

Maintenance—7A16A

2. Apply heat from the soldering iron to the junction between the component and the circuit board.

3. Heat-shunt the lead to the component by means of a pair of long-nose pliers.

4. Avoid excessive heating of the junction with the circuit board, as this could separate the circuit board wiring from the base material.

5. Use electronic grade 60-40 tin lead solder.

6. Clip off any excess lead length extending beyond the circuit board. Clean off any residual flux with a flux-removing solvent.

Metal Terminals. When soldering metal terminals (potentiometers, etc.) use 60-40 tin-lead solder and a 15 to 50 watt soldering iron. Observe the following precautions when soldering metal terminals:

1. Apply only enough heat to make the solder flow freely.

2. Apply only enough solder to form a solid connection. Excess solder may impair the function of the part.

3. If a wire extends beyond the solder joint, clip off the excess.

4. Clean the flux from the solder joint with a flux-removing solvent.

Component Replacement

WARNING

Disconnect the equipment from the power source before replacing components.

Semiconductor Replacement. Transistors should not be replaced unless actually defective. If removed from their sockets during routine maintenance, return them to their original sockets. Unnecessary replacement of transistors may effect the calibration of this instrument. When transistors are replaced, check the performance of the part of the instrument which may be affected.

Replacement semiconductors should be of the original type or a direct replacement. The schematic diagram shows the lead configurations of the semiconductors used in this instrument. If the replacement semiconductor is not of the original type, check the manufacturer's basing diagram for proper basing.

Circuit Board Removal

In general, the circuit boards used in the 7A16A need never be removed unless they must be replaced. Electrical connections to the boards are made by soldered connections. If it is necessary to replace a circuit board assembly, use the following procedures.

A. READOUT CIRCUIT BOARD REMOVAL

1. Disconnect the wires connected to the outside of the board.

2. Remove the seven screws holding the board to the mounting surface.

3. Disconnect the wires connected to the inside of the board.

4. Remove the board from the unit.

5. To replace the board, reverse the order of removal.

B. ATTENUATOR CIRCUIT BOARD REMOVAL

1. Remove the readout board as outlined in the previous procedure.

2. Disconnect the inductor, capacitor, and two ground straps connected to the rear of the board.

3. Loosen the front set screw on the VARIABLE control shaft coupling (use a 0.050-inch hex-key wrench).

4. Remove the red VARIABLE control knob and glass rod from the control shaft.

5. Remove the remaining front-panel knobs using a 1/16-inch hex-key wrench.

6. Remove the front panel from the instrument by prying at center bottom with screwdriver.

7. Remove the attenuator shields.
8. Disconnect the wires and resistor from the INPUT BNC connector.
9. Remove the INPUT BNC connector.
10. Remove the attenuator board with cam switch from the instrument.
11. Replace by reversing the Removal Procedures.

C. AMPLIFIER CIRCUIT BOARD REMOVAL

1. Remove the plastic plug-in guide from the rear of the instrument.
2. Disconnect the wires connected to the board from the front-panel controls.
3. Loosen the hex-socket screw in the coupling of the VARIABLE control shaft using a 0.050-inch hex-key wrench. Pull the VARIABLE knob and glass shaft from the front of the instrument.
4. Disconnect the inductor, capacitor, and two ground straps from the front of the board.
5. Remove the screws and nuts securing the board to the chassis or other mounting surface.
6. Remove the board from the instrument.
7. To replace, reverse the order of removal.

Switch Replacement

Several types of switches are used in the 7A16A. The slide and micro switches should be replaced as a unit if damaged. The following special maintenance information is provided for the cam-type switches.



Repair of cam-type switches should be undertaken only by experienced maintenance personnel. Switch alignment and spring tension of the contacts must be carefully maintained for proper operation of the switch. For assistance in maintenance of cam-type switches, contact your local TEKTRONIX Field Office or representative.

A. CAM-TYPE SWITCHES

A cam-type switch consists of a rotating cam, which is turned by the front-panel knobs, and a set of contacts mounted on an adjacent circuit board. These switch contacts are actuated by lobes on the cam. The VOLTS/DIV and AC-GND-DC (coupling) cam-type switches can be disassembled for inspection, cleaning, repair, or replacement as follows:

1. Remove the Readout board and the Attenuator board/switch assembly as described previously. The front switch section on the Attenuator board is the AC-GND-DC switch and the rear switch section is the VOLTS/DIV switch. The switches are now open for inspection or cleaning.
2. To completely remove the switch from the board, remove the two screws and four hexagonal posts which hold the cam-type switch to the circuit board.
3. To remove the cam from the front support block, remove the retaining ring from the shaft on the front of the switch and slide the cam out of the support block. Be careful not to lose the small detent roller.
4. To replace defective switch contacts, follow the instructions given in the switch repair kit.
5. To re-install the switch assembly, reverse the above procedure.

Recalibration After Repair

After any electrical component has been replaced, the calibration of that particular circuit should be checked, as well as the calibration of other closely related circuits. Refer to Section 5 for these procedures.

CALIBRATION

Introduction

To assure instrument accuracy, check the calibration of the 7A16A every 1000 hours of operation or every six months if used infrequently. Before complete calibration, thoroughly clean and inspect this instrument as outlined in the Maintenance section.

TEKTRONIX Field Service

Tektronix, Inc., provides complete instrument repair and recalibration service at local Field Service Centers and the Factory Service Center. Contact your local field office or representative for further information.

Performance Check

The performance of this instrument can be checked by performing only the steps listed in this procedure. These steps check the instrument against the tolerances listed as a Performance Requirement (see Specification section in the Operators manual).

Limits and tolerances given in other check steps are calibration guides and should not be interpreted as instrument specifications. Operator front-panel adjustments are adjusted as part of the Performance Check procedure.

Calibration

To verify proper calibration of the 7A16A and to prevent unnecessary re-calibration of the entire instrument, perform the Adjust— portion of a step only if the tolerance given in the Check— part of the step is not met.

For best overall instrument performance when performing a complete calibration procedure, make each adjustment to the exact setting even if the Check— is within allowable tolerance.

TEST EQUIPMENT REQUIRED

General

The following test equipment and accessories, or its equivalent, is required for complete calibration of the 7A16A. Specifications given for the test equipment are the minimum necessary for accurate calibration. Therefore, the specifications of any test equipment used must meet or exceed the listed specifications. All test equipment is assumed to be correctly calibrated and operating within the listed specifications. Detailed operating instructions for the test equipment are not given in this procedure. Refer to the instruction manual for the test equipment if more information is needed.

Special Calibration Fixtures

Special TEKTRONIX calibration fixtures are used in this procedure only where they facilitate instrument calibration. These special calibration fixtures are available from Tektronix, Inc. Order by part number through your local TEKTRONIX Field Office or representative.

Calibration Equipment Alternatives

All of the listed test equipment is required to completely check and adjust this instrument. The Calibration procedure is based on the first item of equipment given as an example of applicable equipment. When other equipment is substituted, control settings or the calibration setup may need to be altered slightly to meet the requirements of the substitute equipment. If the exact item of test equipment given as an example in the Test Equipment list is not available, first check the Specifications column carefully to see if any other equipment is available which might suffice. Then check the Usage column to see what this item of test equipment is used for. If used for a check or adjustment which is of little or no importance to your measurement requirements, the item and corresponding step(s) can be deleted.

TEST EQUIPMENT

Description	Minimum Specifications	Usage	Examples of Applicable Test Equipment
Calibration oscilloscope	7000-Series oscilloscope mainframe. 7900-Series required to check 7A16A maximum bandwidth and risetime.	Used throughout procedure to provide display.	1. TEKTRONIX 7904 Oscilloscope. 2. Any TEKTRONIX 7000-Series oscilloscopes. Check Specifications for bandwidth and risetime.
Time Base Unit	7B-Series timebase unit. Sweep speed to 2 ns/div.	Used throughout procedure to provide horizontal sweep.	1. TEKTRONIX 7B70 Time Base or equivalent.
Standard Amplitude Calibrator	Amplitude accuracy, within 0.25%; signal amplitude, 20 mV to 20 V; frequency, 1 kHz square-wave.	Used for gain calibration only.	1. TEKTRONIX Calibration fixture 067-0502-01.
Square-wave Generator	Output Capabilities: 12 V into 50 Ω with a risetime of at least 12 ns and a frequency of approximately 1 kHz; 500 mV into 50 Ω with a risetime of at least 1 ns at 100 kHz.	Used for Input Compensation and Low Frequency Compensation only.	1. TEKTRONIX Type 106 Square-wave Generator.
Pulse Generator	Risetime of at least 70 ps, step amplitude of 200 mV into 50 Ω.	Used for High Frequency Compensation only.	1. TEKTRONIX Type 284 Pulse Generator.
Constant Amplitude Signal Generator	Upper frequency range, 225 MHz; reference frequency, approximately 3 MHz; constant amplitude accuracy, within 2% of reference frequency; amplitude range, 0.5 V to 4 V P-P.	Used for Bandwidth check only.	1. TEKTRONIX Calibration Fixture 067-0532-01.
Accessories			
BNC Cable	Connectors, BNC; length, 42 inches.	Used throughout procedure.	
GR Cable	Connectors, GR; Impedance, 50 Ω; length, approximately 20 inches.	Used for High Frequency Compensation and Risetime only.	TEKTRONIX Part Number 017-0515-00.
X10 Attenuator	Connectors, GR; Impedance, 50 Ω.	Used throughout the procedures.	TEKTRONIX Part Number 017-0078-00.
RC Normalizer	Time Constant, 1 MΩ X 20 pF; connectors, BNC; attenuation, 2X.	Used for Input Compensation.	TEKTRONIX Part Number 067-0538-00
Termination (thru line)	Impedance, 50 Ω; connectors, GR to BNC male.	Used throughout procedures.	TEKTRONIX Part Number 017-0064-00

PERFORMANCE CHECK PROCEDURE

Balance

1. Check DC Bal (R160) vertical deflection of 0.2 division or less while switching between +UP and INVERT.
2. Check 2X Bal (R453) for vertical deflection of 0.2 division or less while switching between 5 mV and 10 mV.
3. Check Var Bal (R553) for vertical deflection of 0.2 division or less while rotating the VARIABLE control throughout the range.

Gain

4. Check/Adjust GAIN control (R516) to obtain a display of exactly four vertical divisions when the VOLTS/DIV switch is set to 5 mV and the standard amplitude calibrator is set to 20 mV square-wave out.
5. Check 2X Gain control (R413) to obtain a display of exactly five vertical divisions when the VOLTS/DIV switch is set to 10 mV and the standard amplitude calibrator is set to 50 mV square-wave out.
6. Check all VOLTS/DIV switch settings: Within 2%.

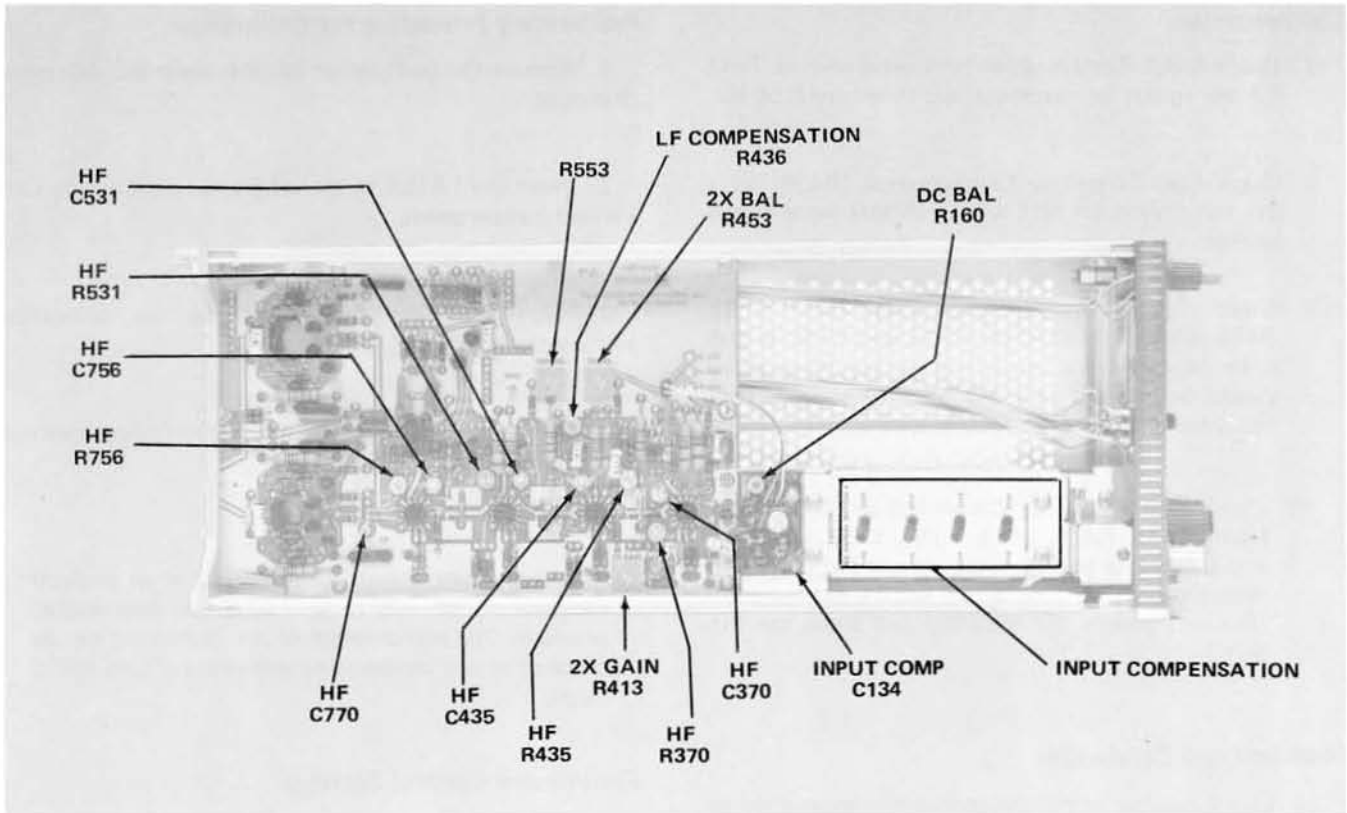

Fig. 5-1a. Location of adjustments, S/N B050000 & up.

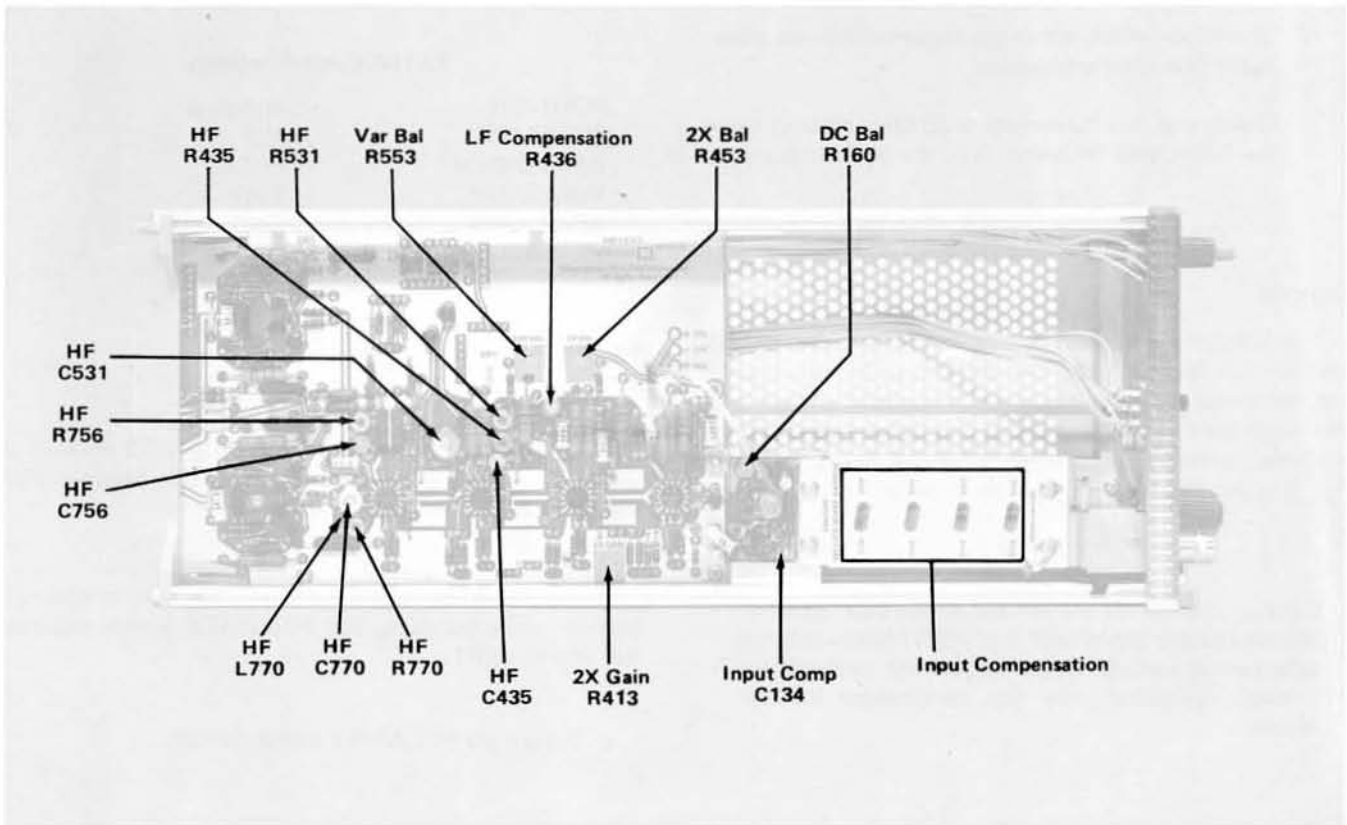

Fig. 5-1b. Location of adjustments, Below S/N B050000.

Calibration—7A16A

Compensation

7. Check Input Compensation controls shown in Table 5-2 for rolloff or overshoot not to exceed 0.06 div.
8. Check Low Frequency Compensation (R436) for a flat top (minimum tilt) with a 25 kHz square-wave applied.
9. Check High Frequency Compensation R531, C531, R435, C435, R756, C756, R770, and C770 in that order for best front corner and flat top. Aberrations should not exceed $\pm 4\%$ and 6% peak-to-peak. (For instruments below SN B050000 see Fig. 5-1b.)
10. Check High Frequency Compensation R370, C370, R531, C531, R435, C435, R756, C756, and C700 in that order for best front corner and flat top. Aberrations should not exceed $\pm 4\%$ and 6% peak-to-peak (For instruments SN B050000 and above see Fig. 5-1a.)

Risetime and Bandwidth

11. Check risetime within the system tolerances given in the Specifications section.
12. Check bandwidth within the system tolerances given in the Specifications section.

Check that the bandwidth is 20 MHz ± 3 MHz when the BANDWIDTH switch is in the 20 MHz position.

CALIBRATION PROCEDURE

General

The following procedure is arranged so that the 7A16A can be calibrated with the least interaction of adjustments and re-connection of equipment. The control settings and test equipment setup throughout this procedure continue from the preceding steps unless otherwise noted. Refer to Fig. 5-1a and Fig. 5-1b for location of adjustments.

NOTE

Control titles which are printed on the front panel of the 7A16A are capitalized (e.g. POSITION). Internal adjustments and associated equipment controls are initially capitalized only (e.g. oscilloscope Vertical Mode).

Preliminary Procedure for Calibration

1. Remove the oscilloscope left side cover and side panel of plug-in.
2. Insert the 7A16A in the calibration oscilloscope Left Vertical compartment.
3. Insert the time base unit into the calibration oscilloscope Horizontal compartment.
4. Turn oscilloscope on and allow 20 minutes warm-up before proceeding.

NOTE

This instrument should be calibrated at an ambient temperature of $+20^{\circ}\text{C}$ to $+30^{\circ}\text{C}$ for best overall accuracy. The performance of the instrument can be checked at any temperature within the 0°C to $+50^{\circ}\text{C}$ range.

Preliminary Control Settings

Set the calibration oscilloscope and time base unit for a sharp, well defined trace. Set the 7A16A control as follows:

7A16A Control Settings

POSITION	midrange
POLARITY	+UP
BANDWIDTH	FULL
VOLTS/DIV	5 mV
AC-DC-GND	GND
VARIABLE	CAL IN

BALANCE

1. Check/Adjust DC Bal

a. Check—that the vertical trace shift is 0.2 division or less while switching the POLARITY switch between +UP and INVERT.

b. Adjust—R160, DC Bal control, for min vertical deflection while switching the POLARITY switch between +UP and INVERT.

c. Return the POLARITY switch to +UP.

2. Check/Adjust 2X Bal

- a. Check—that the vertical trace shift is 0.2 division or less while switching the VOLTS/DIV switch between 10 mV and 5 mV.
- b. Adjust—R453, 2X Bal control, for min vertical deflection while switching the VOLTS/DIV switch between 10 mV and 5 mV.
- c. Return the VOLTS/DIV switch to 5 mV.

3. Check/Adjust Var Bal

- a. Check—that the vertical trace shift is 0.2 division or less while rotating the VARIABLE control throughout the range.
- b. Adjust—R553, Var Bal control, for min vertical deflection while rotating the VARIABLE control throughout the range.
- c. Return the VARIABLE control to the CAL IN position.

GAIN

4. Adjust GAIN

- a. Connect the Standard Amplitude Calibrator to the 7A16A INPUT connector with the 42-inch BNC cable.
- b. Set the AC-GND-DC switch to DC and adjust the Standard Amplitude Calibrator to obtain a 20 mV square-wave.
- c. Adjust—the front panel GAIN control to obtain a display of exactly 4 divisions.

5. Check/Adjust 2X Gain

- a. Set the VOLTS/DIV switch to 10 mV and adjust the Standard Amplitude Calibrator to obtain a 50 mV square-wave.
- b. Check—that the display amplitude is 5 divisions ± 0.1 division.
- c. Adjust—R413, 2X Gain control, to obtain a vertical display of exactly 5 division.

- d. Rotate VARIABLE control CCW and check for 2 div or less of display.
- e. Set VARIABLE control to the CAL IN position.

6. Check All VOLTS/DIV Gain Settings

- a. Check—that all VOLTS/DIV gain settings are within 2%. Refer to Table 5-1 for control settings and tolerances.
- b. Return the VOLTS/DIV switch to 10 mV and disconnect the Standard Amplitude Calibrator.

TABLE 5-1

Vertical Deflection Accuracy

VOLTS/DIV Switch Setting	Standard Amplitude Calibrator Output	Vertical Deflection in Divisions	Maximum Error for $\pm 2\%$ Accuracy (divisions)
5 mV	20 mV	4	± 0.08
10 mV	50 mV	5	± 0.1
20 mV	0.1 V	5	± 0.1
50 mV	0.2 V	4	± 0.08
.1 V	0.5 V	5	± 0.1
.2 V	1 V	5	± 0.1
.5 V	2 V	4	± 0.08
1 V	5 V	5	± 0.1
2 V	10 V	5	± 0.1
5 V	20 V	4	± 0.08

COMPENSATION

7. Adjust Low Frequency Compensation

- a. Connect the Square-wave Generator to the 7A16A INPUT through a X10 50 Ω attenuator and a 50 Ω terminator.
- b. Set the Square-wave Generator to obtain approximately six vertical divisions of a 1 kHz square-wave.

- c. Adjust—R436, LF compensation control, for best flat top (minimum tilt).

- d. Disconnect the Square-wave Generator.

8. Adjust Input Compensation

- a. Connect the Square-wave Generator to the 7A16A INPUT through a X10 50 Ω attenuator, 50 Ω termination, and a 20 pF RC Normalizer.

Calibration—7A16A

b. Set the Square-wave Generator to obtain a 1 kHz, six-division display. Maintain a six division display for all VOLTS/DIV switch positions, remove the X10 attenuator and the 50 Ω termination when necessary.

c. Adjust—and check compensation for best front corner and flat top as shown in Table 5-2. Rolloff or overshoot should not exceed .06 division.

d. Disconnect the Square-wave Generator from the 7A16A and return the VOLTS/DIV switch to 10 mV.

TABLE 5-2
Attenuator Compensation

VOLTS/DIV Switch Setting	Adjust for Optimum	
	Square Corner	Flat Top
5 mV	Check	Check
10 mV	C134	
20 mV	C106	C107
50 mV	C110	C111
.1 V	C114	C115
.2 V	Check	Check
.5 V	Check	Check
1 V	C118	C119
2 V	Check	Check
5 V	Check	Check

9. Adjust High Frequency Compensation

a. Connect the Pulse Generator to the 7A16A INPUT via a GR cable, X5 GR attenuator, and a 50 Ω Terminator.

b. Set the 7A16A VOLTS/DIV switch to 10 mV and set the Pulse generator for a vertical display of approximately 6 divisions.

c. Set the time base unit to obtain a triggered display at a rate of approximately .02 μ s per division.

d. Position the top of the waveform to 1 division above center screen.

e. Adjust—High Frequency controls: R531, C531, R435, C435, R756, C756, R770, and C770 in that order for best front corner and flat top. Aberrations should not exceed \pm 4% and 6% peak to peak.

f. Adjust—High Frequency controls: R370, C370, R531, C531, R435, C435, R756, C756, and C770 in that order for best front corner and flat top. Aberrations should not exceed \pm 4% and 6% peak to peak. (For instruments B050000 and up.)

NOTE

(For Instruments Below B050000)

If integrated circuit U750 or transistors Q820 or Q840 are replaced, it may become necessary to readjust coil L770. If satisfactory results are not achieved by adjusting all other high frequency controls, then adjust L770 in the following manner: Remove L770 from the plug-in socket and shorten the coil by clipping a small piece with a diagonal cutter. Replace the coil to the plug-in sockets. If aberrations decrease, continue to shorten the coil for optimum results. If the aberrations are increased, form a larger coil using AWG 26 gauge bare wire.

RISETIME AND BANDWIDTH

✓10. Check Risetime

a. Increase the sweep speed of the Time Base unit to approximately 2 ns (0.02 μ s and X10 Mag).

b. Check—that the risetime of the leading edge of the pulse is within the specifications given in Table 5-3.

c. Disconnect all Test equipment.

TABLE 5-3
System Risetime and Bandwidth

Mainframe	Bandwidth	Risetime
7900-Series	*225 MHz	1.6 ns
7700-Series	*150 MHz	2.4 ns
7500-Series	* 90 MHz	3.9 ns
7400-Series	* 60 MHz	5.9 ns

*Depending on the individual mainframe.

✓11. Check Bandwidth

a. Connect the Constant Amplitude Signal Generator to the 7A16A INPUT thru a 50 Ω termination.

b. Set the Constant Amplitude Signal Generator to the reference frequency of 3 MHz and adjust the output amplitude to obtain a 6 division display.

c. Change the frequency of the Constant Amplitude Signal Generator to the value given in Table 5-3.

d. Check—that the amplitude of the display is 4.2 div or greater.

This completes the calibration for the 7A16A.

REPLACEABLE ELECTRICAL PARTS

PARTS ORDERING INFORMATION

Replacement parts are available from or through your local Tektronix, Inc. Field Office or representative.

Changes to Tektronix instruments are sometimes made to accommodate improved components as they become available, and to give you the benefit of the latest circuit improvements developed in our engineering department. It is therefore important, when ordering parts, to include the following information in your order: Part number, instrument type or number, serial number, and modification number if applicable.

If a part you have ordered has been replaced with a new or improved part, your local Tektronix, Inc. Field Office or representative will contact you concerning any change in part number.

Change information, if any, is located at the rear of this manual.

SPECIAL NOTES AND SYMBOLS

X000 Part first added at this serial number

00X Part removed after this serial number

ITEM NAME

In the Parts List, an Item Name is separated from the description by a colon (:). Because of space limitations, an Item Name may sometimes appear as incomplete. For further Item Name identification, the U.S. Federal Cataloging Handbook H6-1 can be utilized where possible.

ABBREVIATIONS

ACTR	ACTUATOR	PLSTC	PLASTIC
ASSY	ASSEMBLY	QTZ	QUARTZ
CAP	CAPACITOR	RECP	RECEPTACLE
CER	CERAMIC	RES	RESISTOR
CKT	CIRCUIT	RF	RADIO FREQUENCY
COMP	COMPOSITION	SEL	SELECTED
CONN	CONNECTOR	SEMICOND	SEMICONDUCTOR
ELECTLT	ELECTROLYTIC	SENS	SENSITIVE
ELEC	ELECTRICAL	VAR	VARIABLE
INCAND	INCANDESCENT	WW	WIREWOUND
LED	LIGHT EMITTING DIODE	XFMR	TRANSFORMER
NONWIR	NON WIREWOUND	XTAL	CRYSTAL

CROSS INDEX MFR. CODE NUMBER TO MANUFACTURER

MFR.CODE	MANUFACTURER	ADDRESS	CITY,STATE,ZIP
00853	Sangamo Electric Co., S. Carolina Div.	P. O. Box 128	Pickens, SC 29671
01121	Allen-Bradley Co.	1201 2nd St. South	Milwaukee, WI 53204
01295	Texas Instruments, Inc., Semiconductor Group	P. O. Box 5012	Dallas, TX 75222
03508	General Electric Co., Semi-Conductor Products Dept.	Electronics Park	Syracuse, NY 13201
07263	Fairchild Semiconductor, A Div. of Fairchild Camera and Instrument Corp.	464 Ellis St.	Mountain View, CA 94042
07910	Teledyne Semiconductor	12515 Chadron Ave.	Hawthorne, CA 90250
17856	Siliconix, Inc.	2201 Laurelwood Rd.	Santa Clara, CA 95054
24931	Specialty Connector Co., Inc.	3560 Madison Ave.	Indianapolis, IN 46227
50157	N. L. Industries, Inc., Electronics Dept.	P. O. Box 787	Muskegon, MI 49443
56289	Sprague Electric Co.		North Adams, MA 01247
72982	Erie Technological Products, Inc.	644 W. 12th St.	Erie, PA 16512
73138	Beckman Instruments, Inc., Helipot Div.	2500 Harbor Blvd.	Fullerton, CA 92634
74970	Johnson, E. F., Co.	299 10th Ave. S. W.	Waseca, MN 56093
75042	TRW Electronic Components, IRC Fixed Resistors, Philadelphia Division	401 N. Broad St.	Philadelphia, PA 19108
79727	C-W Industries	550 Davisville Rd.	Warminster, PA 18974
80009	Tektronix, Inc.	P. O. Box 500	Beaverton, OR 97077
80294	Bourns, Inc., Instrument Div.	6135 Magnolia Ave.	Riverside, CA 92506
80740	Beckman Instruments, Inc.	2500 Harbor Blvd.	Fullerton, CA 92634
90201	Mallory Capacitor Co., Div. of P. R. Mallory Co., Inc.	3029 E. Washington St.	Indianapolis, IN 46206

Ckt No.	Tektronix Part No.	Serial/Model No.		Name & Description	Mfr Code	Mfr Part Number
		Eff	Dscont			
A1	670-2324-01	B010100	B059999	CKT BOARD ASSY:ATTENUATOR	80009	670-2324-01
A1	670-2324-00	B060000	B069999	CKT BOARD ASSY:ATTENUATOR	80009	670-2324-00
A1	670-2324-03	B070000		CKT BOARD ASSY:ATTENUATOR	80009	670-2324-03
A2	670-2323-00	B010100	B049999	CKT BOARD ASSY:AMPLIFIER	80009	670-2323-00
A2	670-2323-01	B050000	B089999	CKT BOARD ASSY:AMPLIFIER	80009	670-2323-01
A2	670-2323-02	B090000		CKT BOARD ASSY:AMPLIFIER	80009	670-2323-02
A3	670-2310-01	B010100	B059999	CKT BOARD ASSY:READOUT	80009	670-2310-01
A3	670-2310-00	B060000		CKT BOARD ASSY:READOUT	80009	670-2310-00
C10	285-0816-01			CAP.,FXD,PLSTC:0.19UF,10%,600V	80009	285-0816-01
C13	283-0000-00			CAP.,FXD,CER DI:0.001UF,+100-0%,500V	72982	831-516E102P
C15	283-0000-00			CAP.,FXD,CER DI:0.001UF,+100-0%,500V	72982	831-516E102P
C106 } C107 }	307-1010-01			ATTENUATOR,FXD:2X	80009	307-1010-01
C110 } C111 }	307-1012-00			ATTENUATOR,FXD:5X	80009	307-1012-00
C114 } C115 }	307-1013-01			ATTENUATOR,FXD:10X	80009	307-1013-01
C117	281-0626-00	B010100	B069999X	CAP.,FXD,CER DI:3.3PF,1%,500V	72982	301-000C0J0339B
C118 } C119 }	307-1013-01			ATTENUATOR,FXD:10X	80009	307-1013-01
C130	281-0670-00	B010100	B069999	CAP.,FXD,CER DI:1.8PF,+/-0.1PF,500V	72982	374-005C0K0189B
C130	281-0064-00	B070000		CAP.,VAR,PLSTC:0.25-1.5PF,600V	72982	530-002
C132	283-0000-00			CAP.,FXD,CER DI:0.001UF,+100-0%,500V	72982	831-516E102P
C134	281-0064-00			CAP.,VAR,PLSTC:0.25-1.5PF,600V	72982	530-002
C140	281-0615-00	B010100	B069999	CAP.,FXD,CER DI:3.9PF,+/-0.5PF,200V	72982	374-001C0J0399D
C140	290-0536-00	B070000		CAP.,FXD,ELCTLT:10UF,20%,25V	90201	TDC106M025FL
C142	283-0156-00	XB070000		CAP.,FXD,CER DI:1000PF,+100-0%,200V	72982	8111A208E102Z
C144 ¹	283-0156-00	XB062454		CAP.,FXD,CER DI:1000PF,+100-0%,200V	72982	8111A208E102Z
C150	281-0562-00	B010100	B069999X	CAP.,FXD,CER DI:39PF,10%,500V	72982	301-000U2J0390K
C154	283-0000-00	B010100	B069999X	CAP.,FXD,CER DI:0.001UF,+100-0%,500V	72982	831-516E102P
C156	283-0156-00	XB070000		CAP.,FXD,CER DI:1000PF,+100-0%,200V	72982	8111A208E102Z
C158	290-0536-00			CAP.,FXD,ELCTLT:10UF,20%,25V	90201	TDC106M025FL
C190	281-0600-00	B010100	B079999X	CAP.,FXD,CER DI:35PF,10%,500V	72982	308-000C0G0350K
C334	281-0628-00			CAP.,FXD,CER DI:15PF,5%,600V	72982	301-000C0G0150G
C329	283-0000-00	B010100	B049999X	CAP.,FXD,CER DI:0.001UF,+100-0%,500V	72982	831-516E102P
C331	283-0041-00	B010100	B089999	CAP.,FXD,CER DI:0.0033UF,5%,500V	72982	841-541B332J
C331	283-0083-00	B090000		CAP.,FXD,CER DI:0.0047UF,(NOM VALUE),SEL	72982	811-565C472J
C332	283-0026-00			CAP.,FXD,CER DI:0.2UF,+80-20%,25V	56289	274C3
C350	283-0000-00			CAP.,FXD,CER DI:0.001UF,+100-0%,500V	72982	831-516E102P
C370	281-0186-00	XB050000	B089999X	CAP.,VAR,PLSTC:1.1-3.5PF,100V		
C431	281-0546-00			CAP.,FXD,CER DI:330PF,10%,500V	72982	301-000X5P0331K
C434	281-0540-00			CAP.,FXD,CER DI:51PF,5%,500V	72982	301-000U2J0510J
C435	281-0123-00			CAP.,VAR,CER DI:5-25PF,100V	72982	518-000A5-25
C436	283-0010-00			CAP.,FXD,CER DI:0.05UF,+100-20%,50V	56289	273C20
C530	281-0628-00	B010100	B049999X	CAP.,FXD,CER DI:15PF,5%,600V	72982	301-000C0G0150G
C531	281-0167-00	B010100	B049999	CAP.,VAR,CER DI:9-45PF,200V	72982	538-011-D 9-45
C531	281-0158-00	B050000		CAP.,VAR,CER DI:7-45PF,50V	72982	518-000G7-45
C534	283-0003-00			CAP.,FXD,CER DI:0.01UF,+80-20%,150V	72982	855-547E103Z
C538	283-0238-00	B010100	B029999	CAP.,FXD,CER DI:0.01UF,10%,50V	72982	8121N071WR5103K
C538	283-0191-00	B030000	B089999X	CAP.,FXD,CER DI:0.022UF,20%,50V	72982	8121N063651223M
C621	283-0000-00			CAP.,FXD,CER DI:0.001UF,+100-0%,500V	72982	831-516E102P
C630	283-0000-00			CAP.,FXD,CER DI:0.001UF,+100-0%,500V	72982	831-516E102P
C634	283-0000-00			CAP.,FXD,CER DI:0.001UF,+100-0%,500V	72982	831-516E102P
C635	283-0000-00			CAP.,FXD,CER DI:0.001UF,+100-0%,500V	72982	831-516E102P

¹Added if necessary.

Electrical Parts List—7A16A

Ckt No.	Tektronix		Serial/Model No.		Name & Description	Mfr	
	Part No.	Eff	Dscont	Code		Mfr Part Number	
C638	283-0000-00				CAP.,FXD,CER DI:0.001UF,+100-0%,500V	72982	831-516E102P
C643	283-0000-00				CAP.,FXD,CER DI:0.001UF,+100-0%,500V	72982	831-516E102P
C647	283-0000-00				CAP.,FXD,CER DI:0.001UF,+100-0%,500V	72982	831-516E102P
C648	283-0003-00				CAP.,FXD,CER DI:0.01UF,+80-20%,150V	72982	855-547E103Z
C649	283-0000-00				CAP.,FXD,CER DI:0.001UF,+100-0%,500V	72982	831-516E102P
C721	281-0534-00				CAP.,FXD,CER DI:3.3PF,+/-0.25PF,500V	72982	301-000C0J0339C
C754	283-0067-00	B010100	B089999		CAP.,FXD,CER DI:0.001UF,10%,200V	72982	835-515B102K
C754	283-0238-00	B090000			CAP.,FXD,CER DI:0.01UF,(NOM VALUE),SEL	72982	8121N071WR5103K
C756	281-0161-00				CAP.,VAR,CER DI:5-15PF,350V	72982	518-000A5-15
C770	281-0168-00	B010100	B049999		CAP.,VAR,AIR DI:1.3-5.4PF,250V	74970	187-0103-035
C770	281-0064-00	B050000			CAP.,VAR,PLSTC:0.25-1.5PF,600V	72982	530-002
C820	283-0010-00				CAP.,FXD,CER DI:0.05UF,+100-20%,50V	56289	273C20
C840	283-0010-00				CAP.,FXD,CER DI:0.05UF,+100-20%,50V	56289	273C20
C860	283-0644-00	B010100	B069999		CAP.,FXD,MICA D:150PF,1%,500V	00853	D155E151F0
C860	283-0640-00	B070000			CAP.,FXD,MICA D:160PF,1%,100V	00853	D151E161F0
C880	281-0603-00				CAP.,FXD,CER DI:39PF,5%,500V	72982	308-000C0G0390J
C903	281-0557-00	B010100	B049999X		CAP.,FXD,CER DI:1.8PF,10%,500V	72982	301-000C0K0189B
C920	283-0010-00				CAP.,FXD,CER DI:0.05UF,+100-20%,50V	56289	273C20
C940	283-0010-00				CAP.,FXD,CER DI:0.05UF,+100-20%,50V	56289	273C20
C960	283-0644-00				CAP.,FXD,MICA D:150PF,1%,500V	00853	D155E151F0
C980	281-0603-00				CAP.,FXD,CER DI:39PF,5%,500V	72982	308-000C0G0390J
C1010	283-0002-00				CAP.,FXD,CER DI:0.01UF,+80-20%,500V	72982	811-546E103Z
C1012	283-0002-00				CAP.,FXD,CER DI:0.01UF,+80-20%,500V	72982	811-546E103Z
C1020	283-0002-00				CAP.,FXD,CER DI:0.01UF,+80-20%,500V	72982	811-546E103Z
C1022	283-0002-00				CAP.,FXD,CER DI:0.01UF,+80-20%,500V	72982	811-546E103Z
CR130	152-0321-00				SEMICONV DEVICE:SILICON,35V,100MA	07263	FSA1480
CR507	152-0141-02				SEMICONV DEVICE:SILICON,30V,150MA	07910	1N4152
CR621	152-0141-02				SEMICONV DEVICE:SILICON,30V,150MA	07910	1N4152
CR631	152-0141-02				SEMICONV DEVICE:SILICON,30V,150MA	07910	1N4152
CR647	152-0141-02				SEMICONV DEVICE:SILICON,30V,150MA	07910	1N4152
CR720	152-0141-02				SEMICONV DEVICE:SILICON,30V,150MA	07910	1N4152
CR860	152-0141-02				SEMICONV DEVICE:SILICON,30V,150MA	07910	1N4152
CR880	152-0141-02				SEMICONV DEVICE:SILICON,30V,150MA	07910	1N4152
CR960	152-0141-02				SEMICONV DEVICE:SILICON,30V,150MA	07910	1N4152
CR980	152-0141-02				SEMICONV DEVICE:SILICON,30V,150MA	07910	1N4152
J10	131-0679-00	B010100	B079999		CONNECTOR,RCPT,:BNC W/HARDWARE	24931	28JR168-1
J10	131-0679-02	B080000			CONNECTOR,RCPT,:BNC W/HARDWARE		
L118	108-0557-00	B010100	B069999X		COIL,RF:35NH	80009	108-0557-00
L370	108-0420-00	XB050000	B089999X		COIL,RF:60NH	80009	108-0420-00
L770 ¹	XXX-XXXX-XX	B010100	B049999X				
L860	108-0311-00				COIL,RF:0.18UH		
L880	108-0311-00				COIL,RF:0.18UH		
L960	108-0311-00				COIL,RF:0.18UH		
L980	108-0311-00				COIL,RF:0.18UH		
LR107	108-0744-00	B010100	B069999X		COIL,RF:81NH(WOUND ON A 75 OHM RESISTOR)		
LR111	108-0745-00	B010100	B069999X		COIL,RF:110NH(WOUND ON A 130 OHM RESISTOR)		
LR701	108-0407-00	XB062454			COIL,RF:37NH		
LR703	108-0407-00	XB062454			COIL,RF:37NH		
LR1010	108-0184-00				COIL,RF:3.2UH(WOUND ON A 100 OHM RESISTOR)		
LR1020	108-0184-00				COIL,RF:3.2UH(WOUND ON A 100 OHM RESISTOR)		
Q140	151-0367-00	B010100	B069999X		TRANSISTOR:SILICON,NPN,SEL FROM 3571TP	80009	151-0367-00
Q150A,B	151-1032-00				TRANSISTOR:SILICON,FET,DUAL	17856	DN399
Q620	151-0254-00				TRANSISTOR:SILICON,NPN	03508	2N5308

¹ Test selected length of wire.

Electrical Parts List—7A16A

Ckt No.	Tektronix Part No.	Serial/Model No. Eff	Dscont	Name & Description	Mfr Code	Mfr Part Number
Q720	151-0341-00			TRANSISTOR:SILICON,NPN	07263	2N3565
Q730	151-0341-00			TRANSISTOR:SILICON,NPN	07263	2N3565
Q820						
Q840						
Q860	153-0606-00			TRANSISTOR:SILICON,NPN,SELECTED QUAD		
Q880						
Q920	151-0271-00			TRANSISTOR:SILICON,PNP	01295	SKA4504
Q940	151-0271-00			TRANSISTOR:SILICON,PNP	01295	SKA4504
Q960	151-0221-00			TRANSISTOR:SILICON,PNP	80009	151-0221-00
Q980	151-0221-00			TRANSISTOR:SILICON,PNP	80009	151-0221-00
R10	315-0560-00			RES.,FXD,COMP:56 OHM,5%,0.25W	01121	CB5605
R13	316-0101-00			RES.,FXD,COMP:100 OHM,10%,0.25W	01121	CB1011
R102	316-0105-00			RES.,FXD,COMP:1M OHM,10%,0.25W	01121	CB1051
R104	315-0560-00			RES.,FXD,COMP:56 OHM,5%,0.25W	01121	CB5605
R106	317-0330-00	XB070000		RES.,FXD,COMP:33 OHM,(NOM VALUE),SEL	01121	BB3305
R110	317-0470-00	XB070000		RES.,FXD,COMP:47 OHM,(NOM VALUE),SEL	01121	BB4705
R114	317-0220-00	XB070000		RES.,FXD,COMP:22 OHM,(NOM VALUE),SEL	01121	BB2205
R115	315-0430-00	B010100	B069999	RES.,FXD,COMP:43 OHM,5%,0.25W	01121	CB4305
R115	315-0560-00	B070000		RES.,FXD,COMP:56 OHM,(NOM VALUE),SEL	01121	CB5605
R118	315-0330-00	B010100	B039999	RES.,FXD,COMP:33 OHM,5%,0.25W	01121	CB3305
R118	315-0360-00	B040000	B069999	RES.,FXD,COMP:36 OHM,(NOM VALUE),SEL	01121	CB3605
R118	315-0750-00	B070000		RES.,FXD,COMP:75 OHM,(NOM VALUE),SEL	01121	CB7505
R119	317-0360-00	XB070000		RES.,FXD,COMP:36 OHM,(NOM VALUE),SEL	01121	BB3605
R130	321-0481-01			RES.,FXD,FILM:1M OHM,0.5%,0.125W	75042	CEAT0-1004D
R132	316-0474-00			RES.,FXD,COMP:470K OHM,10%,0.25W	01121	CB4741
R133 ¹						
R134	315-0751-00	B010100	B069999	RES.,FXD,COMP:750 OHM,5%,0.25W	01121	CB7515
R134	315-0471-00	B070000		RES.,FXD,COMP:470 OHM,5%,0.25W	01121	CB4715
R140	315-0621-00	B010100	B069999	RES.,FXD,COMP:620 OHM,5%,0.25W	01121	CB6215
R140	315-0201-00	B070000		RES.,FXD,COMP:200 OHM,5%,0.25W	01121	CB2015
R142	315-0132-00	B010100	B069999	RES.,FXD,COMP:1.3K OHM,5%,0.25W	01121	CB1325
R142	315-0621-00	B070000		RES.,FXD,COMP:620 OHM,5%,0.25W	01121	CB6215
R144	315-0221-00	B010000	B069999X	RES.,FXD,COMP:220 OHM,5%,0.25W	01121	CB2215
R145	315-0560-00	B010100	B069999X	RES.,FXD,COMP:56 OHM,5%,0.25W	01121	CB5605
R150	315-0200-00			RES.,FXD,COMP:20 OHM,5%,0.25W	01121	CB2005
R151	315-0560-00	B010100	B069999X	RES.,FXD,COMP:56 OHM,5%,0.25W	01121	CB5605
R152	315-0200-00			RES.,FXD,COMP:20 OHM,5%,0.25W	01121	CB2005
R154	316-0105-00	B010100	B069999X	RES.,FXD,COMP:1M OHM,10%,0.25W	01121	CB1051
R156	315-0201-00			RES.,FXD,COMP:200 OHM,5%,0.25W	01121	CB2015
R158	315-0621-00			RES.,FXD,COMP:620 OHM,5%,0.25W	01121	CB6215
R160	311-1268-00			RES.,VAR,NONWIR:10K OHM,10%,0.50W	73138	62PT-351-0
R162	315-0200-00			RES.,FXD,COMP:20 OHM,5%,0.25W	01121	CB2005
R164	315-0562-00			RES.,FXD,COMP:5.6K OHM,5%,0.25W	01121	CB5625
R301	316-0271-00			RES.,FXD,COMP:270 OHM,10%,0.25W	01121	CB2711
R303	316-0271-00			RES.,FXD,COMP:270 OHM,10%,0.25W	01121	CB2711
R305	315-0391-00			RES.,FXD,COMP:390 OHM,5%,0.25W	01121	CB3915
R307	315-0391-00			RES.,FXD,COMP:390 OHM,5%,0.25W	01121	CB3915
R311	315-0272-00			RES.,FXD,COMP:2.7K OHM,5%,0.25W	01121	CB2725
R313	315-0272-00			RES.,FXD,COMP:2.7K OHM,5%,0.25W	01121	CB2725
R320	323-0179-00			RES.,FXD,FILM:715 OHM,1%,0.50W		
R323	323-0179-00			RES.,FXD,FILM:715 OHM,1%,0.50W		
R327	316-0822-00			RES.,FXD,COMP:8.2K OHM,10%,0.25W	01121	CB8221
R329	316-0822-00			RES.,FXD,COMP:8.2K OHM,10%,0.25W	01121	CB8221
R331	315-0242-00	B010100	B029999	RES.,FXD,COMP:2.4K OHM,5%,0.25W	01121	CB2425
R331	315-0182-00	B030000	B089999	RES.,FXD,COMP:1.8K OHM,5%,0.25W	01121	CB1825

¹ Selected and added if necessary.

Electrical Parts List—7A16A

Ckt No.	Tektronix Part No.	Serial/Model No. Eff	Dscont	Name & Description	Mfr Code	Mfr Part Number
R331	315-0122-00	B090000		RES.,FXD,COMP:1.2K OHM,(NOM VALUE),SEL	01121	CB1225
R332	315-0362-00	B010100	B029999	RES.,FXD,COMP:3.6K OHM,5%,0.25W	01121	CB3625
R332	315-0682-00	B030000		RES.,FXD,COMP:6.8K OHM,5%,0.25W	01121	CB6825
R350	316-0330-00	XB040000		RES.,FXD,COMP:33 OHM,10%,0.25W	01121	CB3301
R352	316-0330-00	XB040000		RES.,FXD,COMP:33 OHM,10%,0.25W	01121	CB3301
R370	311-1260-00	XB050000	B089999X	RES.,VAR,NONWIR:250 OHM,10%,0.50W	73138	62PT-345-0
R401	321-0069-00			RES.,FXD,FILM:51.1 OHM,1%,0.125W	75042	CEATO-51R10F
R403	321-0069-00			RES.,FXD,FILM:51.1 OHM,1%,0.125W	75042	CEATO-51R10F
R405	323-0139-00			RES.,FXD,FILM:274 OHM,1%,0.50W	75042	CECTO-2740F
R411	315-0202-00			RES.,FXD,COMP:2K OHM,5%,0.25W	01121	CB2025
R413	311-1226-00			RES.,VAR,NONWIR:2.5K OHM,20%,0.50W	80294	3389F-P31-252
R414	316-0271-00			RES.,FXD,COMP:270 OHM,10%,0.25W	01121	CB2711
R415	315-0302-00			RES.,FXD,COMP:3K OHM,5%,0.25W	01121	CB3025
R417	315-0302-00			RES.,FXD,COMP:3K OHM,5%,0.25W	01121	CB3025
R419	316-0681-00			RES.,FXD,COMP:680 OHM,10%,0.25W	01121	CB6811
R420	323-0198-00			RES.,FXD,FILM:1.13K OHM,1%,0.50W		
R423	323-0198-00			RES.,FXD,FILM:1.13K OHM,1%,0.50W		
R431	315-0512-00	B010100	B029999	RES.,FXD,COMP:5.1K OHM,5%,0.25W	01121	CB5125
R431	315-0202-00	B030000	B089999	RES.,FXD,COMP:2K OHM,5%,0.25W	01121	CB2025
R431	315-0182-00	B090000		RES.,FXD,COMP:1.8K OHM,(NOM VALUE),SEL	01121	CB1825
R432	316-0330-00	XB040000	B089999	RES.,FXD,COMP:33 OHM,10%,0.25W	01121	CB3301
R432	315-0101-00	B090000		RES.,FXD,COMP:100 OHM,5%,0.25W	01121	CB1015
R433	316-0330-00	XB040000	B089999	RES.,FXD,COMP:33 OHM,10%,0.25W	01121	CB3301
R433	315-0101-00	B090000		RES.,FXD,COMP:100 OHM,5%,0.25W	01121	CB1015
R434	315-0162-00	B010100	B029999	RES.,FXD,COMP:1.6K OHM,5%,0.25W	01121	CB1625
R434	315-0911-00	B030000	B089999	RES.,FXD,COMP:910 OHM,5%,0.25W	01121	CB9115
R434	315-0511-00	B090000		RES.,FXD,COMP:510 OHM,5%,0.25W	01121	CB5115
R435	311-1259-00			RES.,VAR,NONWIR:100 OHM,10%,0.50W	80294	3329P-L58-101
R436	311-1269-00			RES.,VAR,NONWIR:20K OHM,10%,0.50W	73138	62PT-352-0
R440	321-0069-00			RES.,FXD,FILM:51.1 OHM,1%,0.125W	75042	CEATO-51R10F
R442	321-0069-00			RES.,FXD,FILM:51.1 OHM,1%,0.125W	75042	CEATO-51R10F
R451	316-0822-00			RES.,FXD,COMP:8.2K OHM,10%,0.25W	01121	CB8221
R453	311-1228-00			RES.,VAR,NONWIR:10K OHM,20%,0.50W	80294	3389F-P31-103
R501	321-0069-00			RES.,FXD,FILM:51.1 OHM,1%,0.125W	75042	CEATO-51R10F
R503	321-0069-00			RES.,FXD,FILM:51.1 OHM,1%,0.125W	75042	CEATO-51R10F
R505	323-0139-00			RES.,FXD,FILM:274 OHM,1%,0.50W	75042	CECTO-2740F
R507	315-0562-00			RES.,FXD,COMP:5.6K OHM,5%,0.25W	01121	CB5625
R511	315-0242-00	B010100	B039999	RES.,FXD,COMP:2.4K OHM,5%,0.25W	01121	CB2425
R511	315-0222-00	B040000		RES.,FXD,COMP:2.2K OHM,5%,0.25W	01121	CB2225
R513	315-0201-00			RES.,FXD,COMP:200 OHM,5%,0.25W	01121	CB2015
R515 ¹	311-1421-01			RES.,VAR,NONWIR:2.5K OHM,10%,0.50W		
R516	311-0091-00			RES.,VAR,NONWIR:1K OHM,10%,0.50W	01121	W-3083E
R519	315-0202-00			RES.,FXD,COMP:2K OHM,5%,0.25W	01121	CB2025
R520	323-0213-00	B010100	B069999	RES.,FXD,FILM:1.61K OHM,1%,0.50W	75042	CEATO-1611F
R520	323-0203-00	B070000		RES.,FXD,FILM:1.27K OHM,1%,0.50W	75042	CECTO-1271F
R523	323-0213-00	B010100	B069999	RES.,FXD,FILM:1.61K OHM,1%,0.50W	75042	CECTO-1611F
R523	323-0203-00	B070000		RES.,FXD,FILM:1.27K OHM,1%,0.50W	75042	CECTO-1271F
R531	311-1260-00			RES.,VAR,NONWIR:250 OHM,10%,0.50W	73138	62PT-345-0
R534	315-0562-00			RES.,FXD,COMP:5.6K OHM,5%,0.25W	01121	CB5625
R537	315-0151-00	B010100	B089999X	RES.,FXD,COMP:150 OHM,5%,0.25W	01121	CB1515
R538	315-0562-00	B010100	B029999	RES.,FXD,COMP:5.6K OHM,5%,0.25W	01121	CB5625
R538	315-0202-00	B030000	B089999X	RES.,FXD,COMP:2K OHM,5%,0.25W	01121	CB2025
R540	315-0431-00			RES.,FXD,COMP:430 OHM,5%,0.25W	01121	CB4315
R542	315-0511-00			RES.,FXD,COMP:510 OHM,5%,0.25W	01121	CB5115
R550	316-0270-00	B010100	B049999	RES.,FXD,COMP:27 OHM,10%,0.25W	01121	CB2701

¹Furnished as a unit with S515.

Electrical Parts List—7A16A

Ckt No.	Tektronix Part No.	Serial/Model No.		Name & Description	Mfr	
		Eff	Dscont		Code	Mfr Part Number
R550	316-0330-00	B050000	B089999	RES.,FXD,COMP:33 OHM,10%,0.25W	01121	CB3301
R550	315-0111-00	B090000		RES.,FXD,COMP:110 OHM,5%,0.25W	01121	CB1115
R551	316-0822-00			RES.,FXD,COMP:8.2K OHM,10%,0.25W	01121	CB8221
R552	315-0270-00	B010100	B049999	RES.,FXD,COMP:27 OHM,5%,0.25W	01121	CB2705
R552	316-0330-00	B050000	B089999	RES.,FXD,COMP:33 OHM,10%,0.25W	01121	CB3301
R552	315-0111-00	B090000		RES.,FXD,COMP:110 OHM,5%,0.25W	01121	CB1115
R553	311-1228-00			RES.,VAR,NONWIR:10K OHM,20%,0.50W	80294	3389F-P31-103
R578	315-0152-00			RES.,FXD,COMP:1.5K OHM,5%,0.25W	01121	CB1525
R621	321-0223-00			RES.,FXD,FILM:2.05K OHM,1%,0.125W	75042	CEAT0-2051F
R622	321-0299-00			RES.,FXD,FILM:12.7K OHM,1%,0.125W	75042	CEAT0-1272F
R630	315-0154-00			RES.,FXD,COMP:150K OHM,5%,0.25W	01121	CB1545
R631	315-0753-00			RES.,FXD,COMP:75K OHM,5%,0.25W	01121	CB7535
R633	315-0753-00			RES.,FXD,COMP:75K OHM,5%,0.25W	01121	CB7535
R634	315-0154-00			RES.,FXD,COMP:150K OHM,5%,0.25W	01121	CB1545
R635	321-0344-00			RES.,FXD,FILM:37.4K OHM,1%,0.125W	75042	CEAT0-3742F
R638	315-0154-00			RES.,FXD,COMP:150K OHM,5%,0.25W	01121	CB1545
R639	315-0753-00			RES.,FXD,COMP:75K OHM,5%,0.25W	01121	CB7535
R640	315-0753-00			RES.,FXD,COMP:75K OHM,5%,0.25W	01121	CB7535
R642	315-0513-00			RES.,FXD,COMP:51K OHM,5%,0.25W	01121	CB5135
R643	321-0344-00			RES.,FXD,FILM:37.4K OHM,1%,0.125W	75042	CEAT0-3742F
R645	315-0154-00			RES.,FXD,COMP:150K OHM,5%,0.25W	01121	CB1545
R646	315-0154-00			RES.,FXD,COMP:150K OHM,5%,0.25W	01121	CB1545
R647	315-0133-00			RES.,FXD,COMP:13K OHM,5%,0.25W	01121	CB1335
R648	315-0154-00			RES.,FXD,COMP:150K OHM,5%,0.25W	01121	CB1545
R701	321-0069-00			RES.,FXD,FILM:51.1 OHM,1%,0.125W	75042	CEAT0-51R10F
R703	321-0069-00			RES.,FXD,FILM:51.1 OHM,1%,0.125W	75042	CEAT0-51R10F
R705	321-0093-00	B010100	B069999	RES.,FXD,FILM:90.9 OHM,1%,0.125W	75042	CEAT0-90R90F
R705	321-0088-00	B070000		RES.,FXD,FILM:80.6 OHM,1%,0.125W	75042	CEAT0-80R60F
R710	315-0151-00			RES.,FXD,COMP:150 OHM,5%,0.25W	01121	CB1515
R712	315-0151-00			RES.,FXD,COMP:150 OHM,5%,0.25W	01121	CB1515
R714	315-0301-00			RES.,FXD,COMP:300 OHM,5%,0.25W	01121	CB3015
R716	315-0301-00			RES.,FXD,COMP:300 OHM,5%,0.25W	01121	CB3015
R718	316-0333-00			RES.,FXD,COMP:33K OHM,10%,0.25W	01121	CB3331
R720	316-0472-00			RES.,FXD,COMP:4.7K OHM,10%,0.25W	01121	CB4721
R721	315-0152-00			RES.,FXD,COMP:1.5K OHM,5%,0.25W	01121	CB1525
R730	315-0103-00	B010100	B049999	RES.,FXD,COMP:10K OHM,5%,0.25W	01121	CB1035
R730	315-0153-00	B050000		RES.,FXD,COMP:15K OHM,5%,0.25W	01121	CB1535
R732	315-0103-00	B010100	B049999	RES.,FXD,COMP:10K OHM,5%,0.25W	01121	CB1035
R732	315-0153-00	B050000		RES.,FXD,COMP:15K OHM,5%,0.25W	01121	CB1535
R734	315-0431-00	B010100	B049999	RES.,FXD,COMP:430 OHM,5%,0.25W	01121	CB4315
R734	315-0132-00	B050000		RES.,FXD,COMP:1.3K OHM,5%,0.25W	01121	CB1325
R736 ¹	311-1320-00			RES.,VAR,NONWIR:5K OHM,10%,1W		
R740	316-0330-00	XB040000	B062453	RES.,FXD,COMP:33 OHM,10%,0.25W	01121	CB3301
R740	315-0562-00	B062454	B089999	RES.,FXD,COMP:5.6K OHM,5%,0.25W	01121	CB5625
R740	315-0182-00	B090000		RES.,FXD,COMP:1.8K OHM,(NOM VALUE),SEL	01121	CB1825
R742	316-0330-00	XB040000	B089999	RES.,FXD,COMP:33 OHM,10%,0.25W	01121	CB3301
R742	315-0182-00	B090000		RES.,FXD,COMP:1.8K OHM,(NOM VALUE),SEL	01121	CB1825
R750	308-0552-00			RES.,FXD,WW:750 OHM,1%,3W		
R752	308-0552-00			RES.,FXD,WW:750 OHM,1%,3W		
R754	315-0392-00	B010100	B029999	RES.,FXD,COMP:3.9K OHM,5%,0.25W	01121	CB3925
R754	315-0562-00	B030000	B062453	RES.,FXD,COMP:5.6K OHM,5%,0.25W	01121	CB5625
R754	316-0330-00	B062454	B089999X	RES.,FXD,COMP:33 OHM,10%,0.25W	01121	CB3301
R756	311-1259-00			RES.,VAR,NONWIR:100 OHM,10%,0.50W	80294	3329P-L58-101
R757	315-0751-00	B010100	B029999	RES.,FXD,COMP:750 OHM,5%,0.25W	01121	CB7515
R757	321-0181-00	B030000		RES.,FXD,FILM:750 OHM,1%,0.125W	75042	CEAT0-7500F

¹Furnished as a unit with S736.

Electrical Parts List—7A16A

Ckt No.	Tektronix Part No.	Serial/Model No. Eff	Dscont	Name & Description	Mfr Code	Mfr Part Number
R758	315-0751-00	B010100	B029999	RES.,FXD,COMP:750 OHM,5%,0.25W	01121	CB7515
R758	321-0181-00	B030000		RES.,FXD,FILM:750 OHM,1%,0.125W	75042	CEATO-7500F
R760	315-0122-00			RES.,FXD,COMP:1.2K OHM,5%,0.25W	01121	CB1225
R770	311-0622-00	B010100	B049999X	RES.,VAR,NONWIR:100 OHM,10%,0.50W	80740	62-53-5
R802	315-0560-00			RES.,FXD,COMP:56 OHM,5%,0.25W	01121	CB5605
R804	315-0560-00			RES.,FXD,COMP:56 OHM,5%,0.25W	01121	CB5605
R806	308-0406-00			RES.,FXD,WW:1.2K OHM,1%,3W		
R808	308-0406-00			RES.,FXD,WW:1.2K OHM,1%,3W		
R820	315-0431-00			RES.,FXD,COMP:430 OHM,5%,0.25W	01121	CB4315
R822	321-0230-00			RES.,FXD,FILM:2.43K OHM,1%,0.125W	75042	CEATO-2431F
R824	321-0097-00			RES.,FXD,FILM:100 OHM,1%,0.125W	75042	CEATO-1000F
R828	316-0271-00			RES.,FXD,COMP:270 OHM,10%,0.25W	01121	CB2711
R829	321-0148-00			RES.,FXD,FILM:340 OHM,1%,0.125W	75042	CEATO-3400F
R830	316-0271-00			RES.,FXD,COMP:270 OHM,10%,0.25W	01121	CB2711
R832	321-0230-00			RES.,FXD,FILM:2.43K OHM,1%,0.125W	75042	CEATO-2431F
R834	321-0097-00			RES.,FXD,FILM:100 OHM,1%,0.125W	75042	CEATO-1000F
R840	315-0431-00			RES.,FXD,COMP:430 OHM,5%,0.25W	01121	CB4315
R846	315-0111-00			RES.,FXD,COMP:110 OHM,5%,0.25W	01121	CB1115
R860	316-0470-00			RES.,FXD,COMP:47 OHM,10%,0.25W	01121	CB4701
R880	316-0470-00			RES.,FXD,COMP:47 OHM,10%,0.25W	01121	CB4701
R890	323-0193-00			RES.,FXD,FILM:1K OHM,1%,0.5W	75042	CECTO-1001F
R892	323-0193-00			RES.,FXD,FILM:1K OHM,1%,0.5W	75042	CECTO-1001F
R902	315-0560-00			RES.,FXD,COMP:56 OHM,5%,0.25W	01121	CB5605
R904	315-0560-00			RES.,FXD,COMP:56 OHM,5%,0.25W	01121	CB5605
R906	308-0304-00			RES.,FXD,WW:1.5K OHM,1%,3W		
R908	308-0304-00			RES.,FXD,WW:1.5K OHM,1%,3W		
R920	315-0431-00			RES.,FXD,COMP:430 OHM,5%,0.25W	01121	CB4315
R928	316-0271-00			RES.,FXD,COMP:270 OHM,10%,0.25W	01121	CB2711
R930	316-0271-00			RES.,FXD,COMP:270 OHM,10%,0.25W	01121	CB2711
R940	315-0431-00			RES.,FXD,COMP:430 OHM,5%,0.25W	01121	CB4315
R946	315-0111-00			RES.,FXD,COMP:110 OHM,5%,0.25W	01121	CB1115
R960	316-0470-00			RES.,FXD,COMP:47 OHM,10%,0.25W	01121	CB4701
R980	316-0470-00			RES.,FXD,COMP:47 OHM,10%,0.25W	01121	CB4701
R990	323-0212-00			RES.,FXD,FILM:1.58 OHM,1%,0.50W	75042	CECTO-1581F
R992	323-0212-00			RES.,FXD,FILM:1.58 OHM,1%,0.50W	75042	CECTO-1581F
RL010	316-0470-00			RES.,FXD,COMP:47 OHM,10%,0.25W	01121	CB4701
RL012	316-0470-00			RES.,FXD,COMP:47 OHM,10%,0.25W	01121	CB4701
RT334	307-0127-00			RES.,THERMAL:1K OHM,1%	50157	2D1596
RT539	307-0125-00			RES.,THERMAL:500 OHM,10%,25 DEG C	50157	2D1595
S22A,B	260-0816-00			SWITCH,SLIDE:DPDT,0.5A,125VAC	79727	GF-126-0012A
S32	260-0816-00			SWITCH,SLIDE:DPDT,0.5A,125VAC	79727	GF-126-0012A
S100A ¹				AC/GND/DC		
S100B ¹				VOLTS/DIV		
S515 ²				VARIABLE		
S736 ³				INDENTIFY		
T13	120-0304-00			XFMR,TOROID:3 TURNS SINGLE	80009	120-0304-00
T301	120-0286-00			XFMR,TOROID:2 TURNS,BIFILAR	80009	120-0286-00
U350 ⁴	155-0078-05	B010100	B029999	MICROCIRCUIT,LI:ML,VERT AMPL,SEL	80009	155-0078-05
U350	155-0078-01	B030000		MICROCIRCUIT,LI:ML,VERT AMPL,SEL	80009	155-0078-01
U450	155-0078-07	B010100	B029999	MICROCIRCUIT,LI:ML,VERT AMPL,SEL	80009	155-0078-07
U450 ⁵	155-0078-03	B030000		MICROCIRCUIT,LI:ML,VERT AMPL,SEL	80009	155-0078-03
U550	155-0078-07	B010100	B029999	MICROCIRCUIT,LI:ML,VERT AMPL,SEL	80009	155-0078-07
U550 ⁵	155-0078-03	B030000		MICROCIRCUIT,LI:ML,VERT AMPL,SEL	80009	155-0078-03
U750	155-0078-07	B010100	B029999	MICROCIRCUIT,LI:ML,VERT AMPL,SEL	80009	155-0078-07
U750 ⁵	155-0078-03	B030000		MICROCIRCUIT,LI:ML,VERT AMPL,SEL	80009	155-0078-03

¹See Mechanical Parts List for replacment parts.

⁴155-0078-01, -03, -04, -05 or -07 may be used.

²Furnished as a unit with R515.

⁵155-0078-00, -03, -04 or -07 may be used.

³Furnished as a unit with R736.

SECTION 7

DIAGRAMS AND CIRCUIT BOARD ILLUSTRATIONS

Symbols and Reference Designators

Electrical components shown on the diagrams are in the following units unless noted otherwise:

Capacitors =	Values one or greater are in picofarads (pF). Values less than one are in microfarads (μ F).
Resistors =	Ohms (Ω)

Symbols used on the diagrams are based on USA Standard Y32.2-1967.

Logic symbology is based on MIL-STD-806B in terms of positive logic. Logic symbols depict the logic function performed and may differ from the manufacturer's data.

The following special symbols are used on the diagrams:

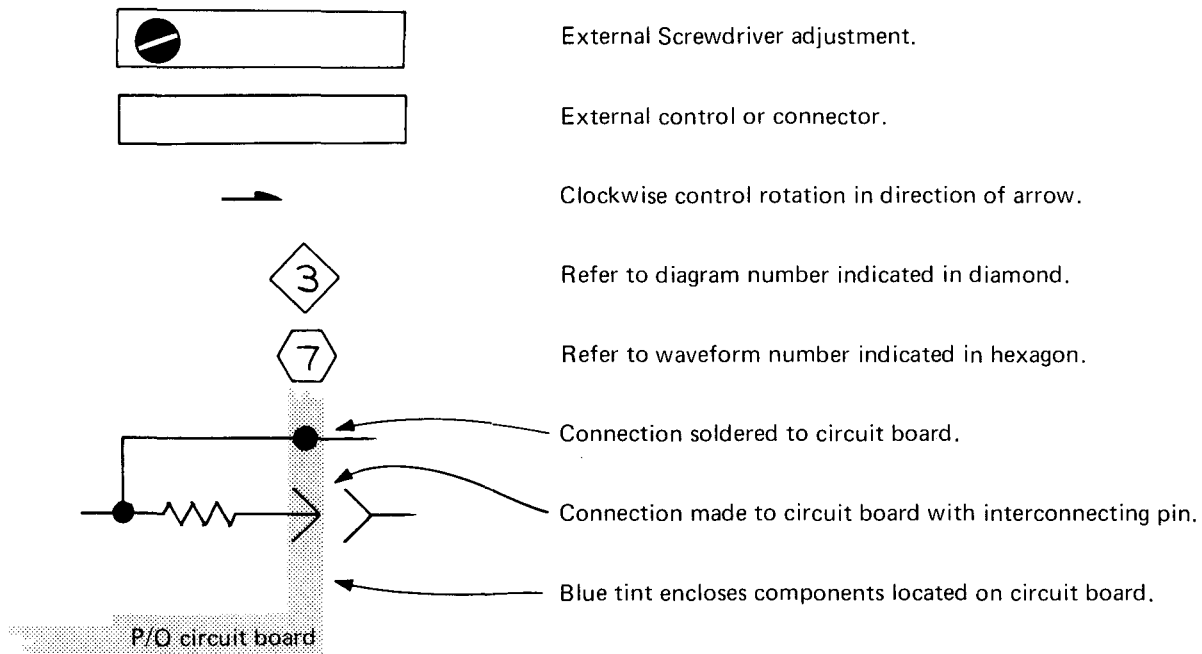

The following prefix letters are used as reference designators to identify components or assemblies on the diagrams.

A	Assembly, separable or repairable (circuit board, etc.)	LR	Inductor/resistor combination
AT	Attenuator, fixed or variable	M	Meter
B	Motor	Q	Transistor or silicon-controlled rectifier
BT	Battery	P	Connector, movable portion
C	Capacitor, fixed or variable	R	Resistor, fixed or variable
CR	Diode, signal or rectifier	RT	Thermistor
DL	Delay line	S	Switch
DS	Indicating device (lamp)	T	Transformer
F	Fuse	TP	Test point
FL	Filter	U	Assembly, inseparable or non-repairable (integrated circuit, etc.)
H	Heat dissipating device (heat sink, heat radiator, etc.)	V	Electron tube
HR	Heater	VR	Voltage regulator (zener diode, etc.)
J	Connector, stationary portion	Y	Crystal
K	Relay		
L	Inductor, fixed or variable		

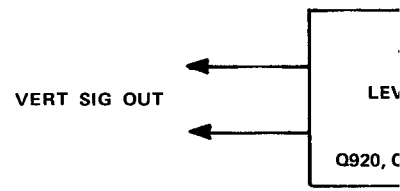
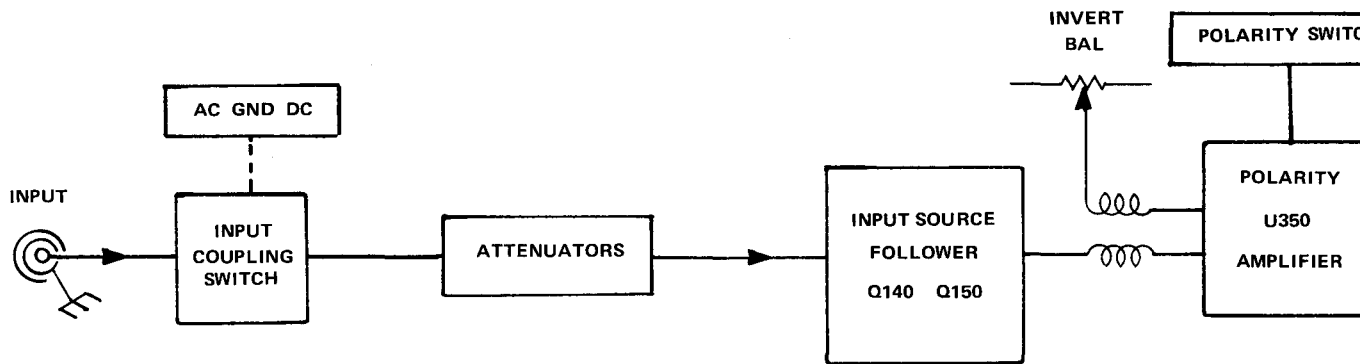

7A16A

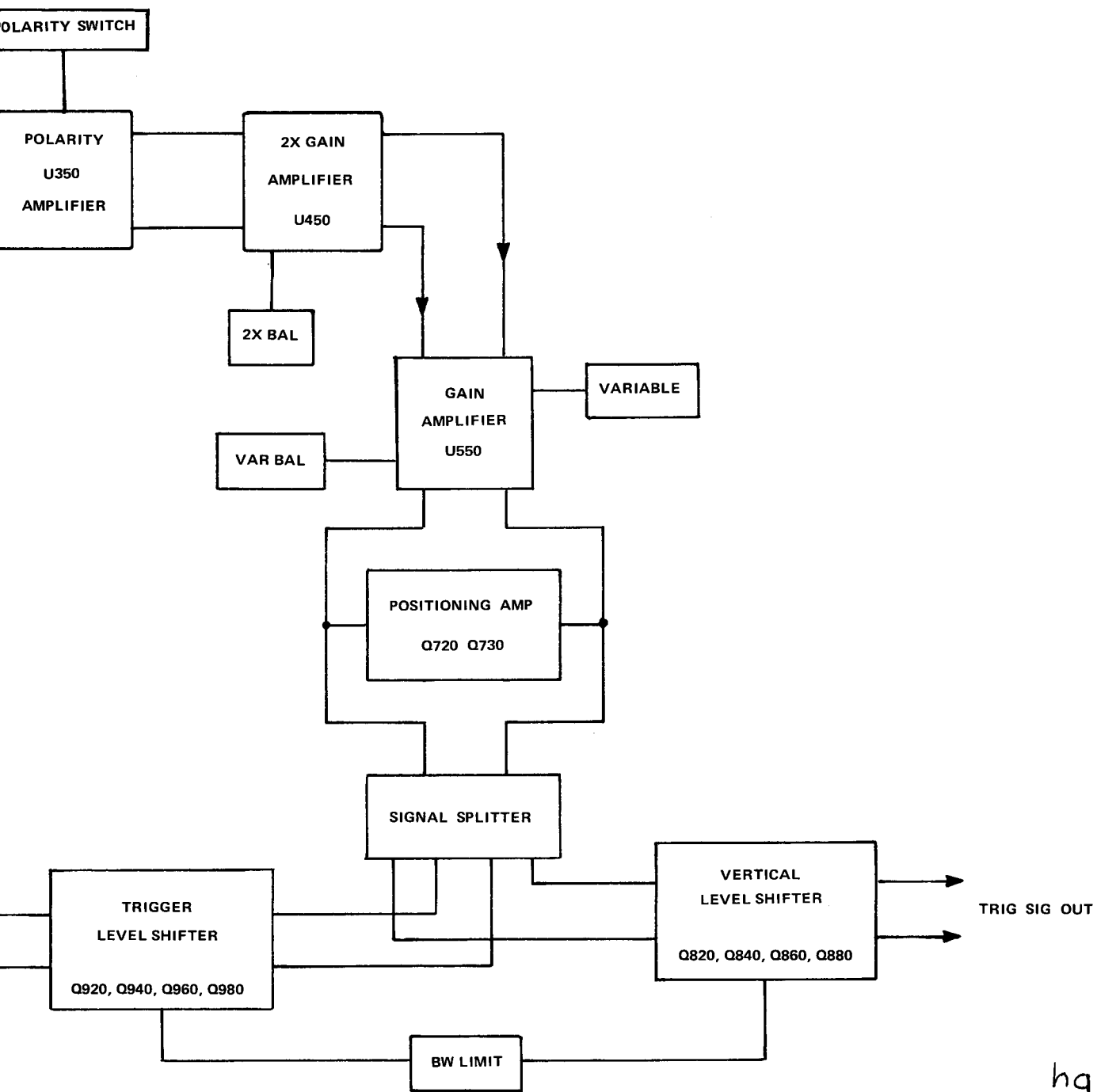

hq
375

BLOCK DIAGRAM

@

Sym
Elec

Sym
Logi
and
The

The
A
AT
B
BT
C
CR
DL
DS
F
FL
H
HR
J
K
L

Ⓐ

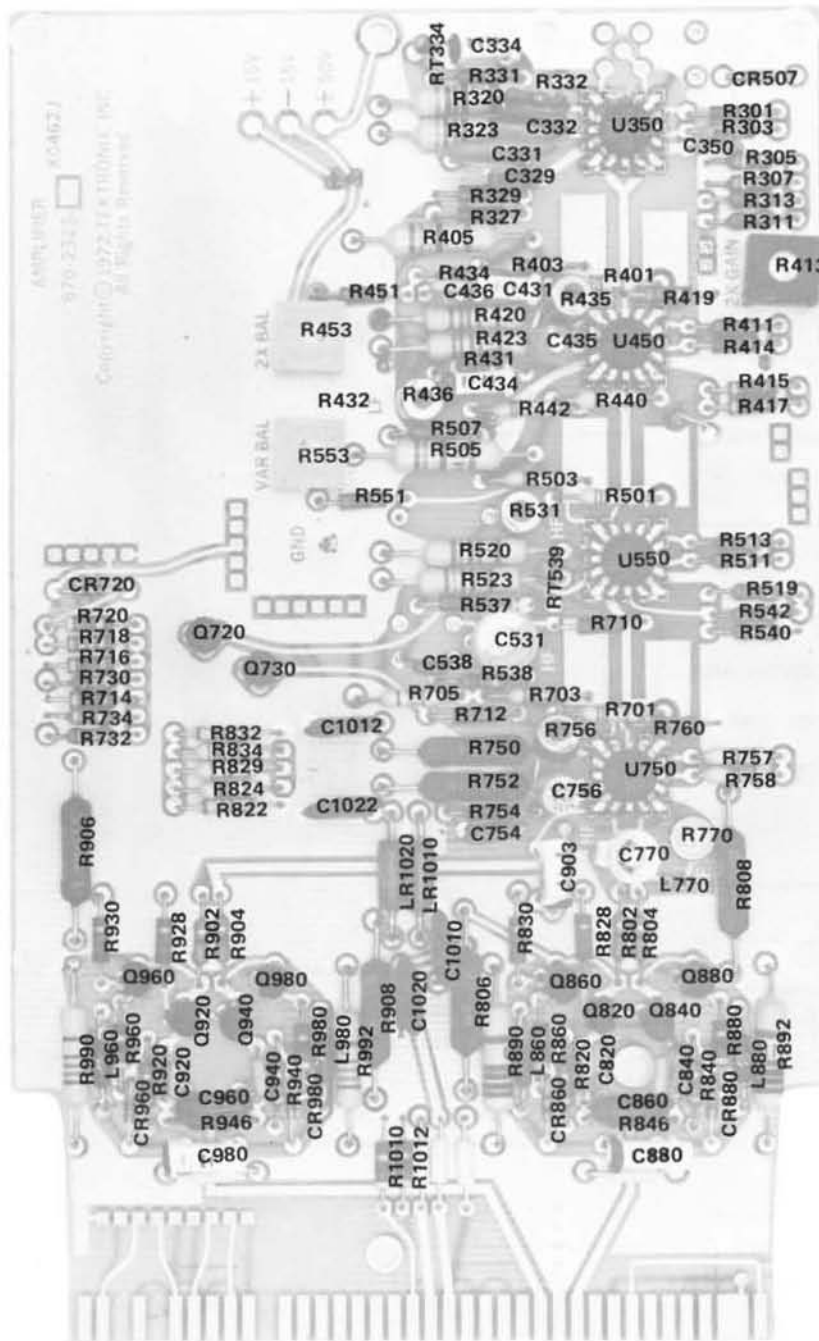

Located on back of board.

- R350
- R352
- R432
- R433
- R740
- R742

7A16A Amplifier Board, Below SN B050000.

*See Parts List for serial number ranges.

REV. JAN 1974

ⓑ

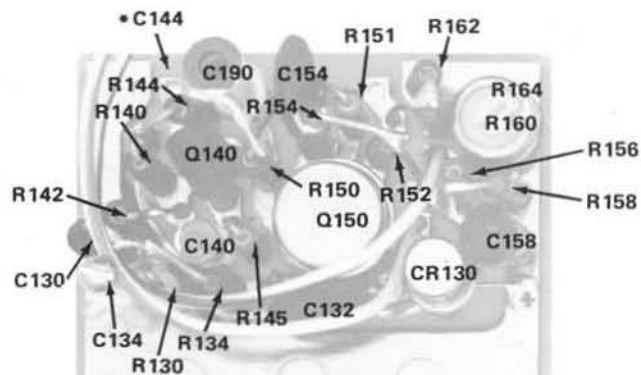
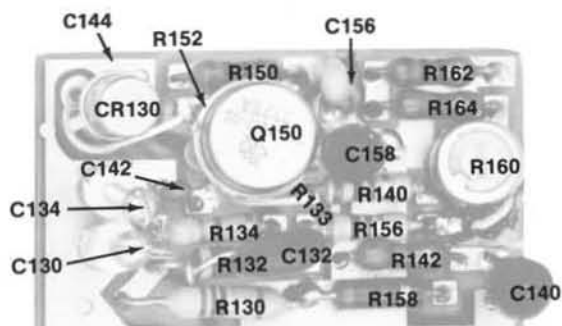

*See Parts List for serial number ranges.

R118 } Located on other side of board
R115 }

Copyright © 1972, TEKTRONIX, INC. All Rights Reserved

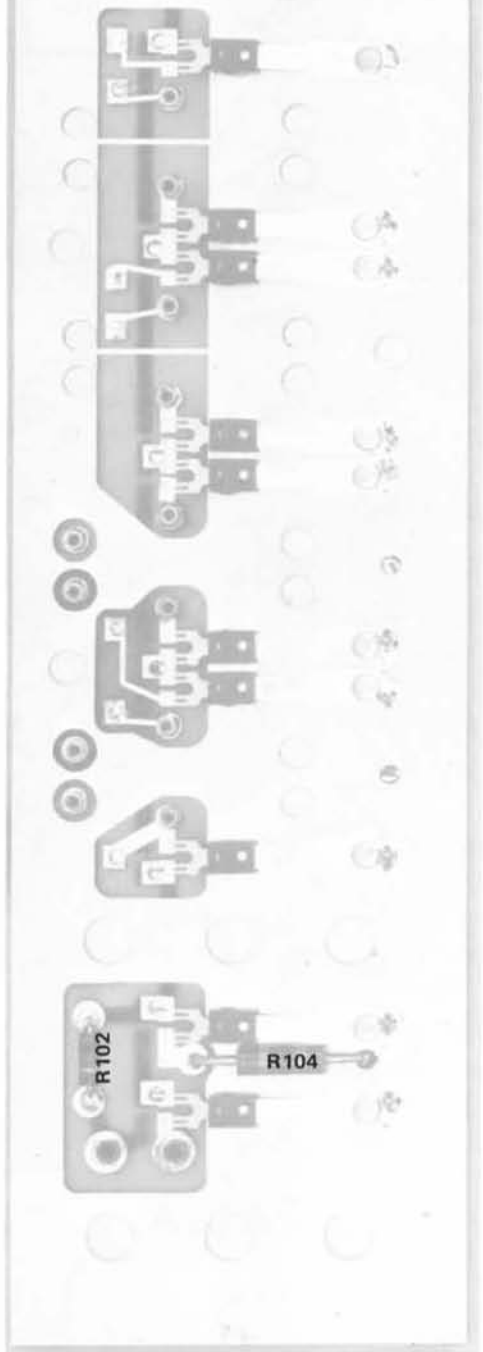

REV. C, SEPT 1974

7A16A Attenuator Board, SN B080000-up.

7A16A Attenuator Board, below SN B080000.

Scans by Outsource-Options =>

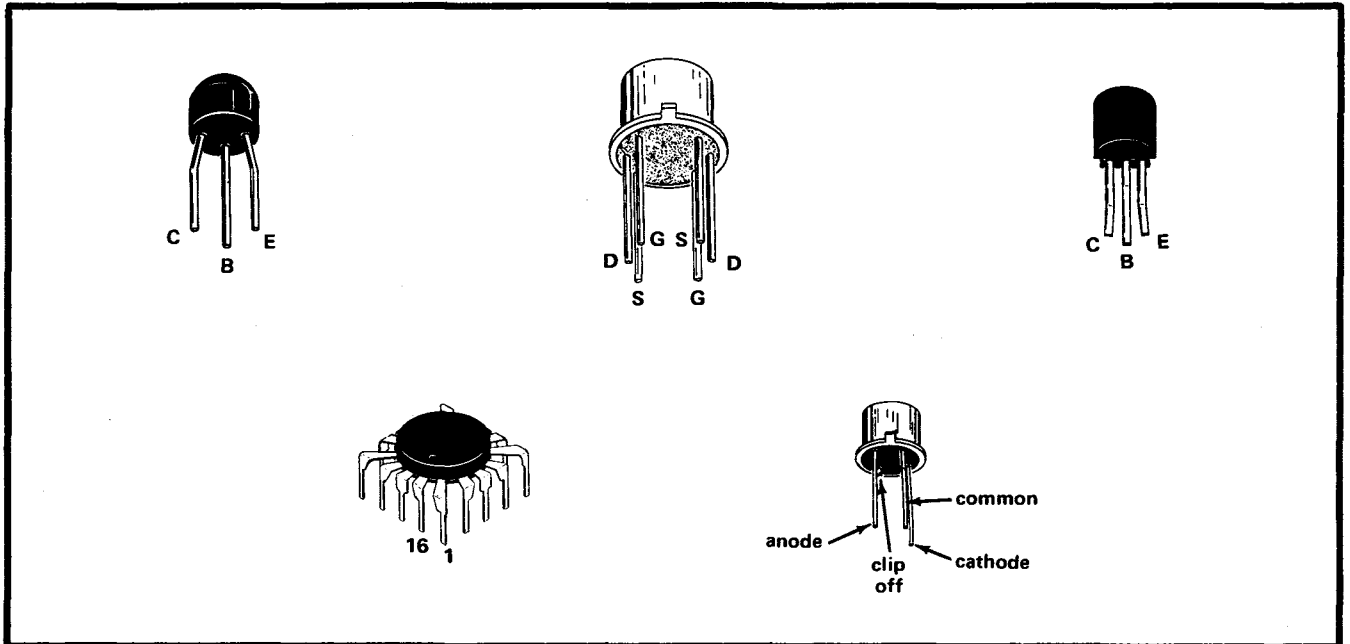

REV. C, SEPT 1974

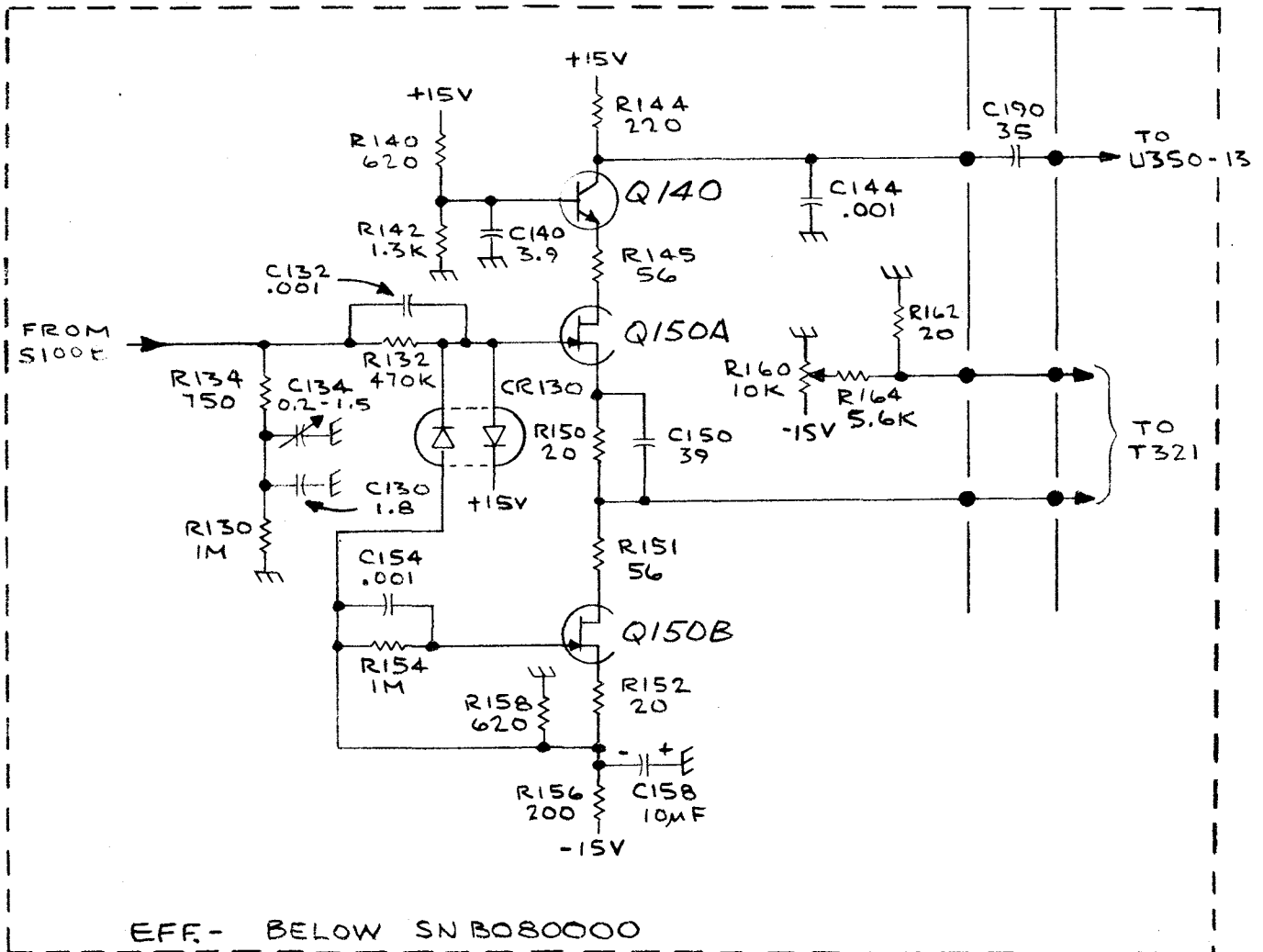

EFF. - BELOW SN B080000

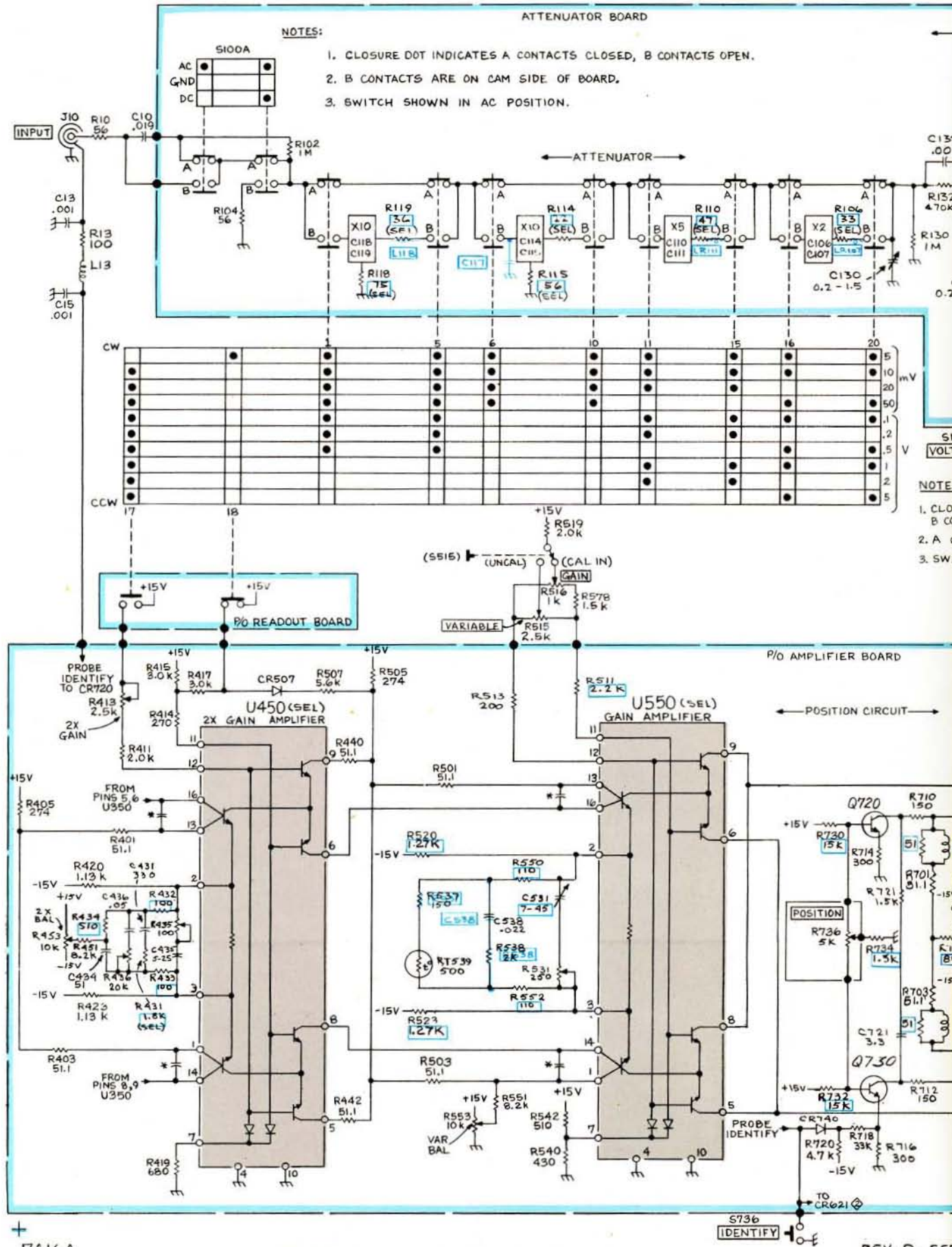

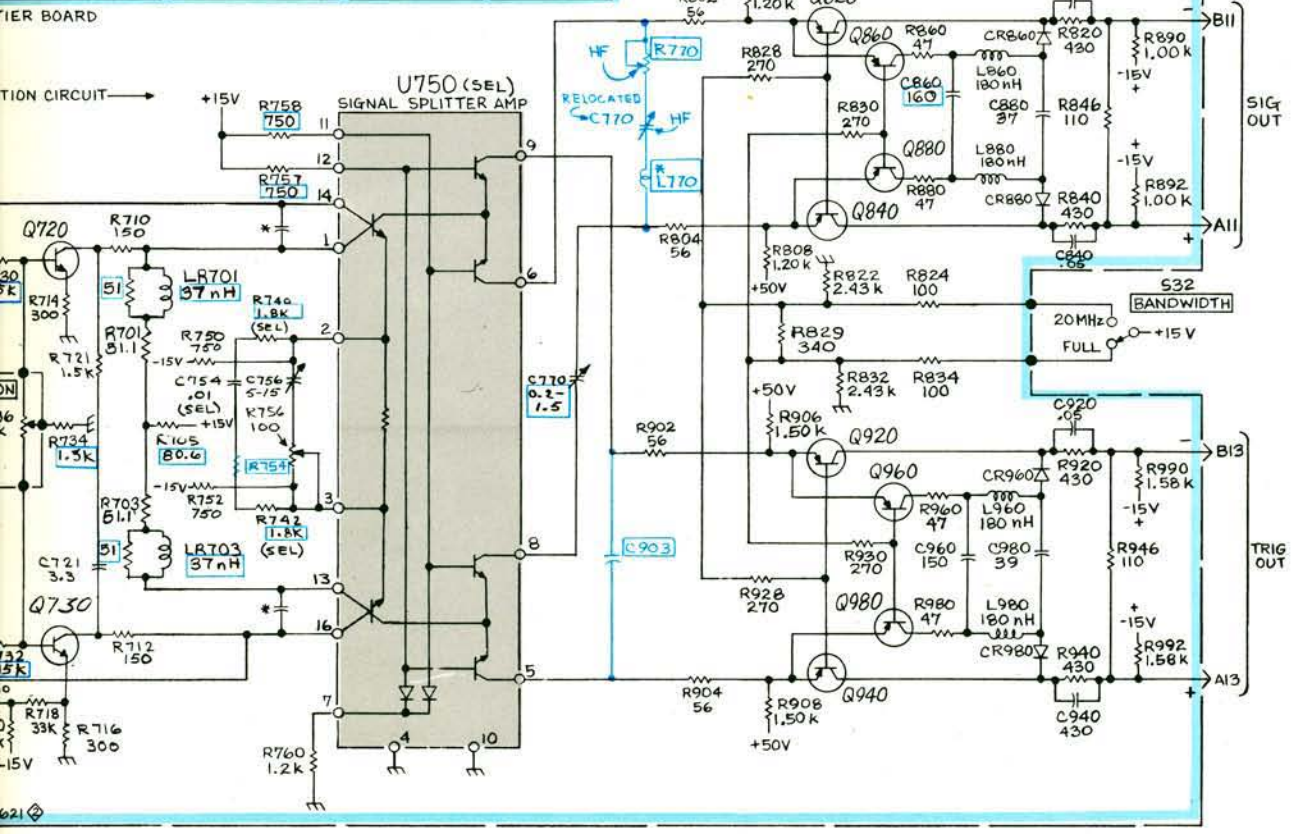
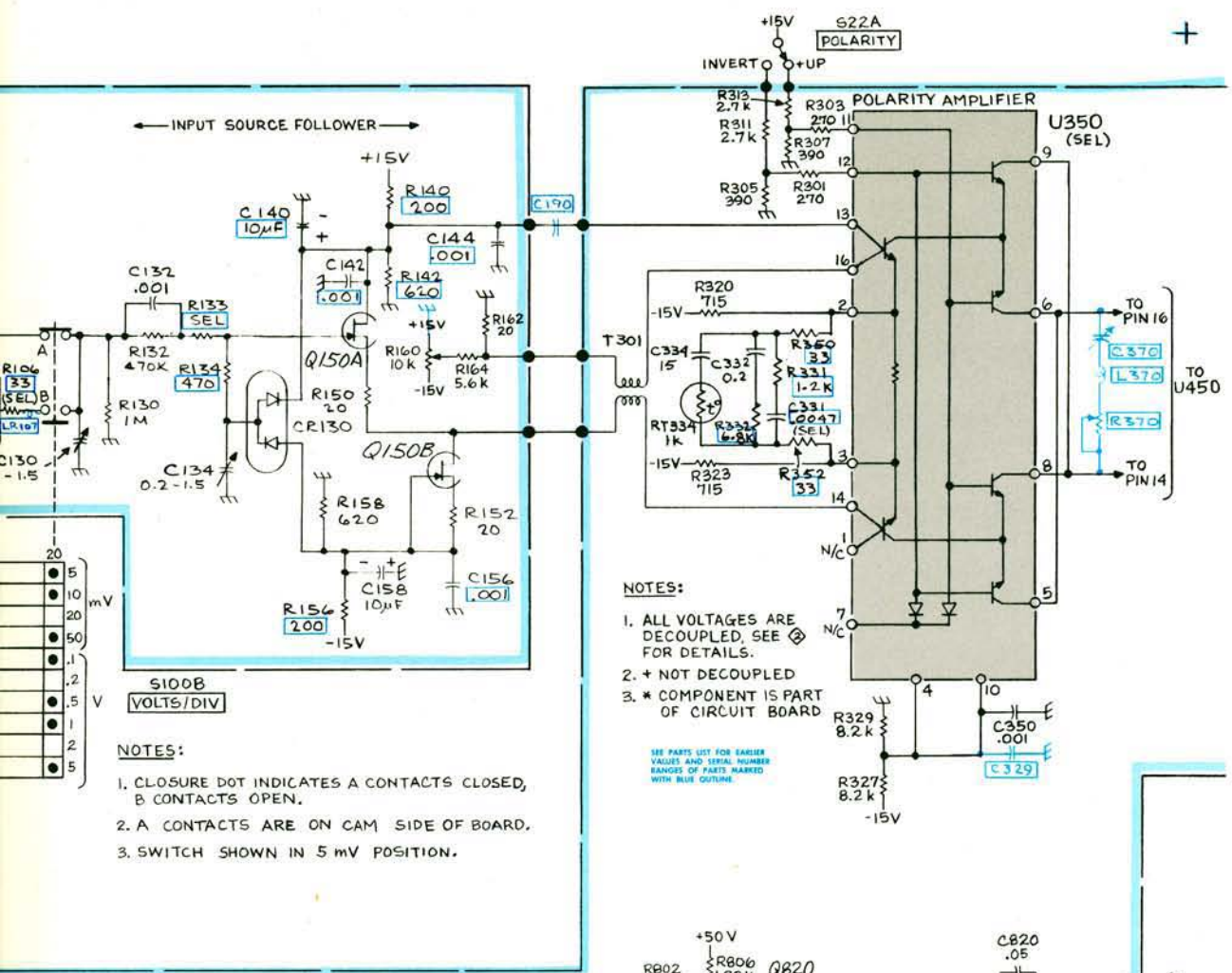

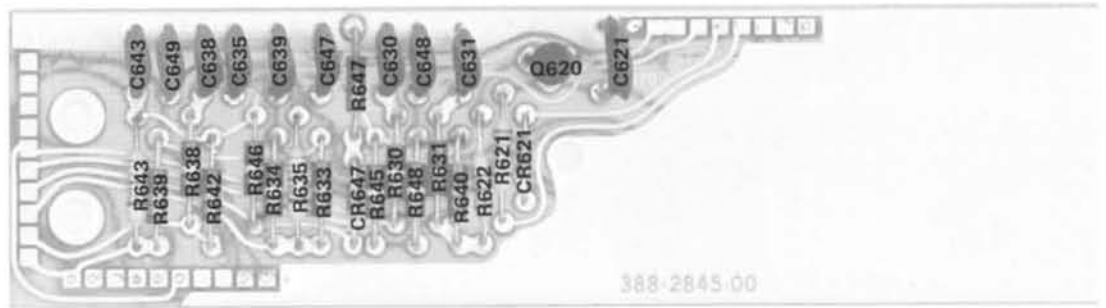

7A16A Readout Board.

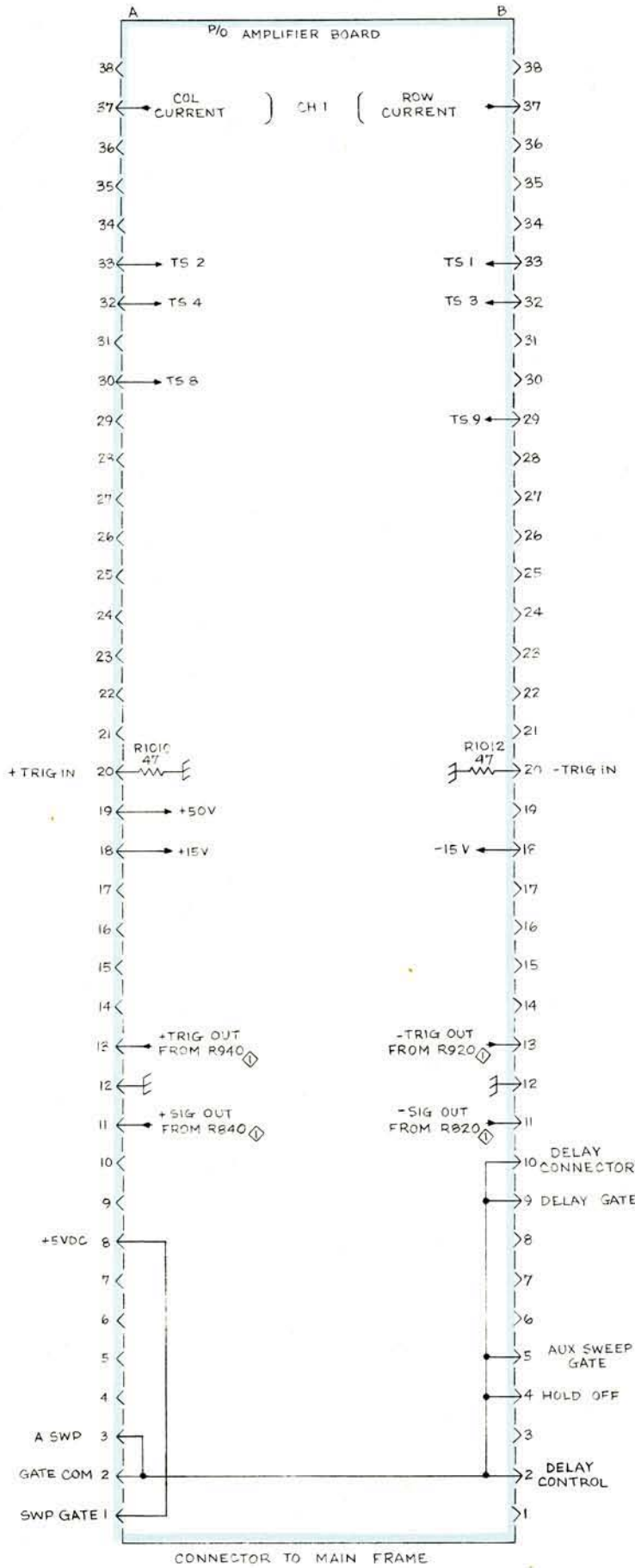

+
7A16A

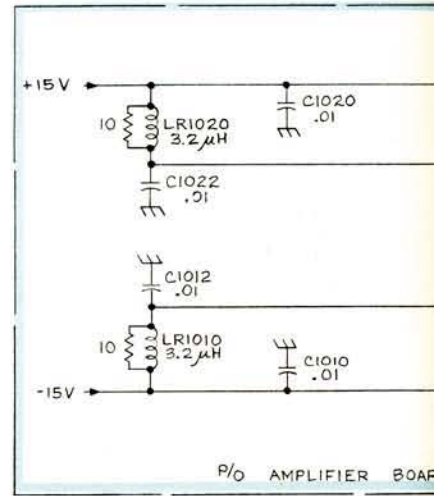
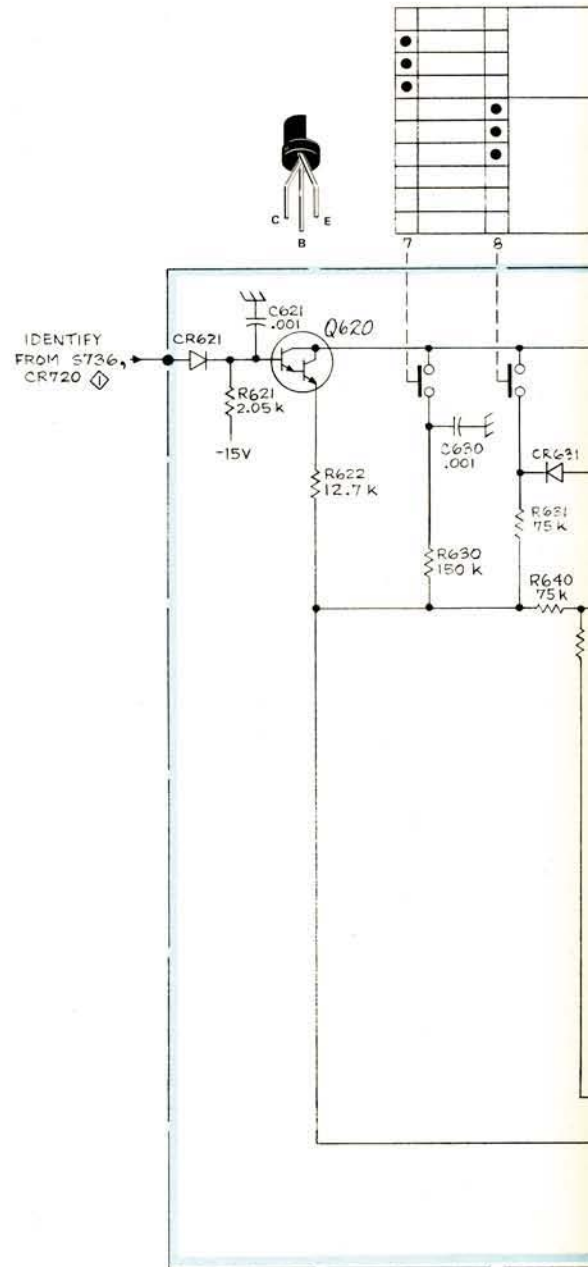

(A)

+

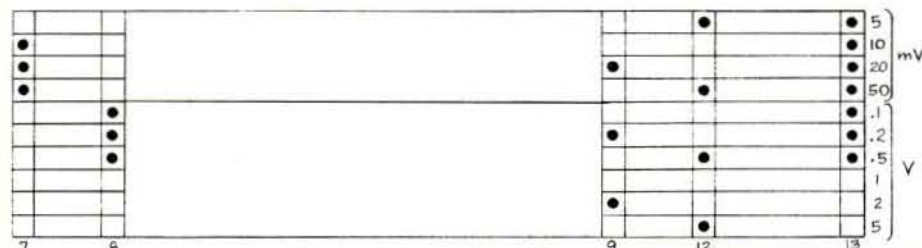

SWITCH SHOWN IN 5 mV POSITION

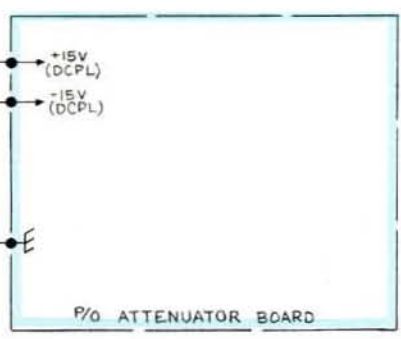
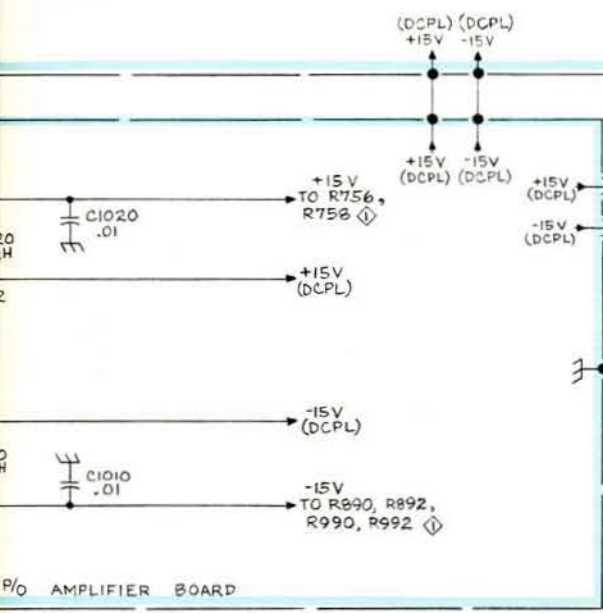
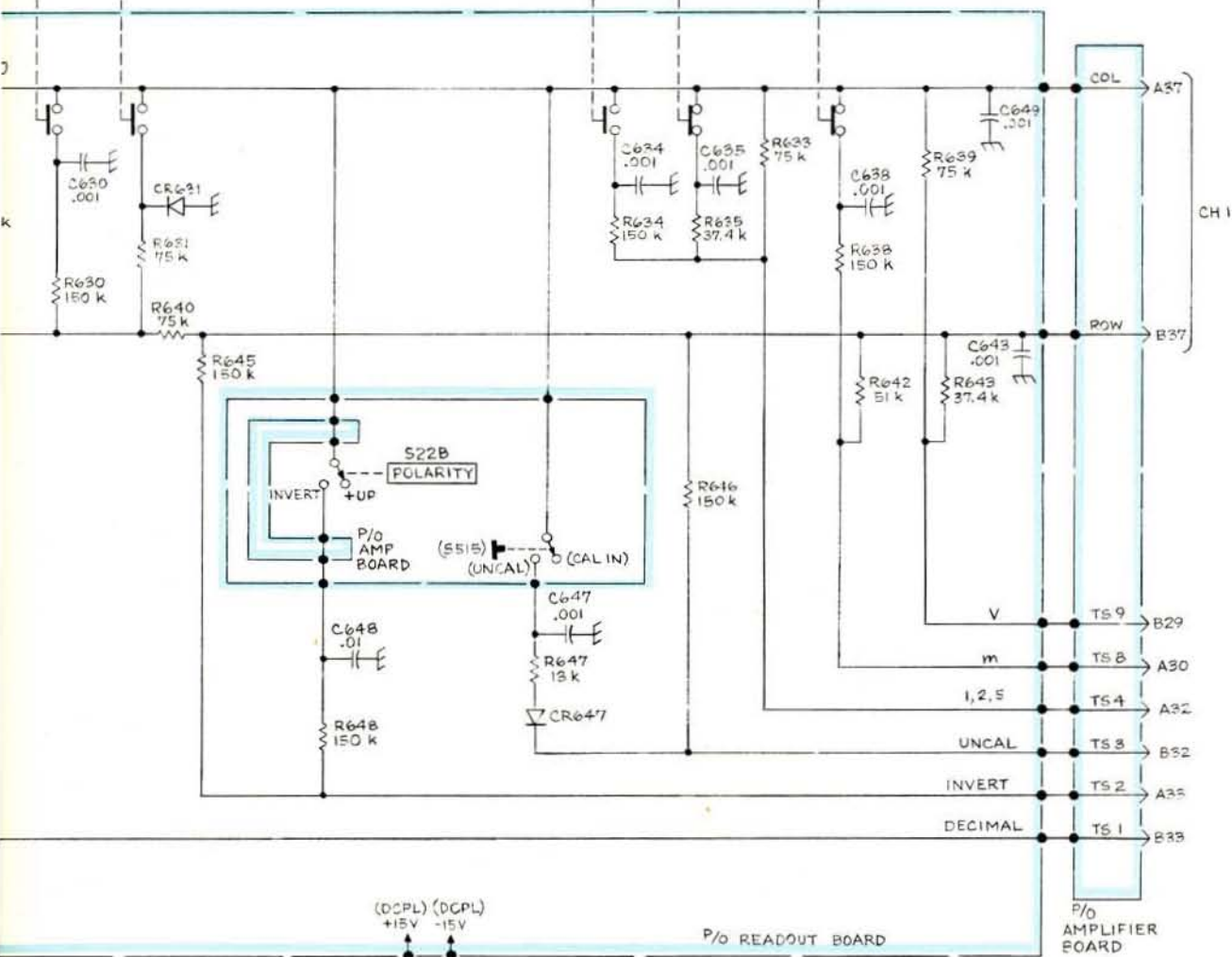

READOUT & MAINFRAME CONNECTOR



READOUT & MAINFRAME CONNECTOR



KIF

REPLACEABLE MECHANICAL PARTS

PARTS ORDERING INFORMATION

Replacement parts are available from or through your local Tektronix, Inc. Field Office or representative.

Changes to Tektronix instruments are sometimes made to accommodate improved components as they become available, and to give you the benefit of the latest circuit improvements developed in our engineering department. It is therefore important, when ordering parts, to include the following information in your order: Part number, instrument type or number, serial number, and modification number if applicable.

If a part you have ordered has been replaced with a new or improved part, your local Tektronix, Inc. Field Office or representative will contact you concerning any change in part number.

Change information, if any, is located at the rear of this manual.

SPECIAL NOTES AND SYMBOLS

X000 Part first added at this serial number
00X Part removed after this serial number

FIGURE AND INDEX NUMBERS

Items in this section are referenced by figure and index numbers to the illustrations.

INDENTATION SYSTEM

This mechanical parts list is indented to indicate item relationships. Following is an example of the indentation system used in the description column.

```

1 2 3 4 5           Name & Description
Assembly and/or Component
Attaching parts for Assembly and/or Component
    --- * ---
Detail Part of Assembly and/or Component
Attaching parts for Detail Part
    --- * ---
Parts of Detail Part
Attaching parts for Parts of Detail Part
    --- * ---
  
```

Attaching Parts always appear in the same indentation as the item it mounts, while the detail parts are indented to the right. Indented items are part of, and included with, the next higher indentation. The separation symbol --- * --- indicates the end of attaching parts.

Attaching parts must be purchased separately, unless otherwise specified.

ITEM NAME

In the Parts List, an Item Name is separated from the description by a colon (:). Because of space limitations, an Item Name may sometimes appear as incomplete. For further Item Name identification, the U.S. Federal Cataloging Handbook H6-1 can be utilized where possible.

ABBREVIATIONS

#	INCH	ELECTRN	ELECTRON	IN	INCH	SE	SINGLE END
ACTR	NUMBER SIZE	ELEC	ELECTRICAL	INCAND	INCANDESCENT	SECT	SECTION
ADPTR	ACTUATOR	ELECTLT	ELECTROLYTIC	INSUL	INSULATOR	SEMICOND	SEMICONDUCTOR
ALIGN	ADAPTER	ELEM	ELEMENT	INTL	INTERNAL	SHLD	SHIELD
AL	ALIGNMENT	EPL	ELECTRICAL PARTS LIST	LPHLDR	LAMPHOLDER	SHLDR	SHOULDERED
AL	ALUMINUM	EQPT	EQUIPMENT	MACH	MACHINE	SKT	SOCKET
ASSEM	ASSEMBLED	EXT	EXTERNAL	MECH	MECHANICAL	SL	SLIDE
ASSY	ASSEMBLY	FIL	FILLISTER HEAD	MTG	MOUNTING	SLFLKG	SELF-LOCKING
ATTEN	ATTENUATOR	FLEX	FLEXIBLE	NIP	NIPPLE	SLVG	SLEEVING
AWG	AMERICAN WIRE GAGE	FLH	FLAT HEAD	NON WIRE	NOT WIRE WOUND	SPR	SPRING
BD	BOARD	FLTR	FILTER	OBD	ORDER BY DESCRIPTION	SQ	SQUARE
BRKT	BRACKET	FR	FRAME or FRONT	OD	OUTSIDE DIAMETER	SST	STAINLESS STEEL
BRS	BRASS	FSTNR	FASTENER	OVH	OVAL HEAD	STL	STEEL
BRZ	BRONZE	FT	FOOT	PH BRZ	PHOSPHOR BRONZE	SW	SWITCH
BSHG	BUSHING	FXD	FIXED	PL	PLAIN or PLATE	T	TUBE
CAB	CABINET	GSKT	GASKET	PLSTC	PLASTIC	TERM	TERMINAL
CAP	CAPACITOR	HDL	HANDLE	PN	PART NUMBER	THD	THREAD
CER	CERAMIC	HEX	HEXAGON	PNH	PAN HEAD	THK	THICK
CHAS	CHASSIS	HEX HD	HEXAGONAL HEAD	PWR	POWER	TNSN	TENSION
CKT	CIRCUIT	HEX SOC	HEXAGONAL SOCKET	RCPT	RECEPTACLE	TPG	TAPPING
COMP	COMPOSITION	HLCP	HELICAL COMPRESSION	RES	RESISTOR	TRH	TRUSS HEAD
CONN	CONNECTOR	HLEXT	HELICAL EXTENSION	RGD	RIGID	V	VOLTAGE
COV	COVER	HV	HIGH VOLTAGE	RLF	RELIEF	VAR	VARIABLE
CPLG	COUPLING	IC	INTEGRATED CIRCUIT	RTNR	RETAINER	W/	WITH
CRT	CATHODE RAY TUBE	ID	INSIDE DIAMETER	SCH	SOCKET HEAD	WSHR	WASHER
DEG	DEGREE	IDENT	IDENTIFICATION	SCOPE	OSCILLOSCOPE	XFMR	TRANSFORMER
DWR	DRAWER	IMPLR	IMPELLER	SCR	SCREW	XSTR	TRANSISTOR

CROSS INDEX MFR. CODE NUMBER TO MANUFACTURER

MFR.CODE	MANUFACTURER	ADDRESS	CITY,STATE,ZIP
0000C	Gettig Engineering and Manufacturing Co.		Springmill, PA 16875
00779	AMP, Inc.	P. O. Box 3608	Harrisburg, PA 17105
08261	Spectra-Strip Corp.	7100 Lampson Ave.	Garden Grove, CA 92642
12360	Albany Products Co., Div. of Pneumo Dynamics Corp.	351 Connecticut Ave.	South Norwalk, CT 06856
13257	Amerace Ltd.	10 Esna Park Dr.	Markham, Ontario, Canada
22526	Berg Electronics, Inc.	Youk Expressway	New Cumberland, PA 17070
23499	Gavitt Wire and Cable, Division of RSC Industries, Inc.	455 N. Quince St.	Escondido, CA 92025
24931	Specialty Connector Co., Inc.	3560 Madison Ave.	Indianapolis, IN 46227
42838	National Rivet and Mfg. Co.	1-21 East Jefferson St.	Waupun, WI 53963
70276	Allen Mfg. Co.	P. O. Drawer 570	Hartford, CT 06101
70278	Allied Steel and Conveyors, Div. of Sparton Corp.	17333 Healy	Detroit, MI 48212
73743	Fischer Special Mfg. Co.	446 Morgan St.	Cincinnati, OH 45206
74445	Holo-Krome Co.	31 Brook St. West	Hartford, CT 06110
78189	Illinois Tool Works, Inc. Shakeproof Division	St. Charles Road	Elgin, IL 60120
79727	C-W Industries	550 Davisville Rd.	Warminster, PA 18974
80009	Tektronix, Inc.	P. O. Box 500	Beaverton, OR 97077
83385	Central Screw Co.	2530 Crescent Dr.	Broadview, IL 60153
87308	N. L. Industries, Inc., Southern Screw Div.	P. O. Box 1360	Statesville, NC 28677
97464	Industrial Retaining Ring Co.	57 Cordier St.	Irvington, NJ 07111

FIGURE 1 EXPLODED

Fig. & Index No.	Tektronix Part No.	Serial/Model No. Eff	Dscnt	Qty						Name & Description	Mfr Code	Mfr Part Number	
					1	2	3	4	5				
1-1	366-1059-00			1						PUSH BUTTON:GRAY	80009	366-1059-00	
-2	366-1077-00			1						KNOB:GRAY	80009	366-1077-00	
	213-0153-00			1						. SETSCREW:5-40 X 0.125 INCH,HEX SOC STL	74445	OBD	
-3	366-1166-00			1						KNOB:RED	80009	366-1166-00	
	213-0153-00			1						. SETSCREW:5-40 X 0.125 INCH,HEX SOC STL	74445	OBD	
-4	366-1299-00			1						KNOB:GRAY	80009	366-1299-00	
	213-0153-00			1						. SETSCREW:5-40 X 0.125 INCH,HEX SOC STL	74445	OBD	
-5	366-0215-02			1						KNOB:LEVER SWITCH	80009	366-0215-02	
-6	366-1058-42			1						KNOB,LATCH:	80009	366-1058-42	
										(ATTACHING PARTS)			
-7	214-1095-00			1						PIN,SPG,SPLIT:0.094 OD X 0.187 INCH LONG	13257	52-022-094-0187	
										- - - * - - -			
-8	105-0076-00			1						REL BAR,LATCH:PLUG-IN UNIT	80009	105-0076-00	
-9	214-1280-00			1						SPRING,HLCPS:0.14 OD X 1.126"L,0.16"DIA W	80009	214-1280-00	
-10	348-0235-00			2						SHLD GSKT,ELEC:4.734 INCH LONG	80009	348-0235-00	
-11	358-0378-00			1						BUSHING,SLEEVE:PRESS MOUNT	80009	358-0378-00	
-12	333-1591-00			1						PANEL,FRONT:	80009	333-1591-00	
-13	131-0679-00	B010100	B079999	1						CONNECTOR,RCPT,:BNC W/HARDWARE	24931	28JR168-1	
	131-0679-02	B080000		1						CONNECTOR,RCPT,:BNC W/HARDWARE	24931	28JR270-1	
										(ATTACHING PARTS)			
	210-1039-00	XB080000		1						WASHER,LOCK:INTL,0.521 ID X 0.625 OD,STL			
	220-0497-00	XB080000		1						NUT,PLAIN,HEX:0.500-28 X 0.562 INCH,BRS			
-14	-----			1						RESISTOR,VAR:(SEE R736/S736 EPL)			
										(ATTACHING PARTS)			
-15	210-0583-00			1						NUT,PLAIN,HEX.:0.25-32 X 0.312 INCH,BRS	73743	2X20319-402	
-16	210-0046-00			1						WASHER,LOCK:INTL,0.26 ID X 0.40" OD,STL	78189	1214-05-00-0541C	
										- - - * - - -			
-17	260-0816-00			2						SWITCH,SLIDE:DPDT,0.5A,125VAC	79727	GF-126-0012A	
										(ATTACHING PARTS FOR EACH)			
-18	211-0030-00			2						SCREW,MACHINE:2-56 X 0.25"82 DEG,FLH STL	83385	OBD	
-19	210-0405-00			2						NUT,PLAIN,HEX.:2-56 X 0.188 INCH,BRS	73743	2X12157-402	
										- - - * - - -			
-20	386-1447-54			1						SUBPANEL,FRONT:	80009	386-1447-54	
										(ATTACHING PARTS)			
-21	213-0192-00			4						SCR,TPG,THD FOR:6-32 X 0.50 INCH,PNH STL	87308	OBD	
										- - - * - - -			
-22	384-1165-00			1						EXTENSION SHAFT:7.80 L X 0.124 OD	80009	384-1165-00	
-23	200-1442-00			1						COVER,ATTEN CHAS:	80009	200-1442-00	
										(ATTACHING PARTS)			
-24	211-0007-00			4						SCREW,MACHINE:4-40 X 0.188 INCH,PNH STL	83385	OBD	
-25	210-0994-00			4						WASHER,FLAT:0.125 ID X 0.25" OD,STL	83385	OBD	
										- - - * - - -			
-26	337-1716-00			1						SHIELD,ELEC:	80009	337-1716-00	
										(ATTACHING PARTS)			
-27	213-0055-00			1						SCR,TPG,THD FOR:2-32 X 0.188 INCH,PNH STL	83385	OBD	
										- - - * - - -			
-28	407-1172-00			1						BRKT,CKT BOARD:	80009	407-1172-00	
										(ATTACHING PARTS)			
-29	211-0008-00			2						SCREW,MACHINE:4-40 X 0.25 INCH,PNH STL	83385	OBD	
-30	210-0586-00			1						NUT,PLAIN,EXT W:4-40 X 0.25 INCH,STL	78189	OBD	
										- - - * - - -			
	672-0051-00	B010100	B059999	1						CKT BOARD ASSY:ATTENUATOR/READOUT	80009	672-0051-00	
	672-0051-01	B060000	B079999	1						CKT BOARD ASSY:ATTENUATOR/READOUT	80009	672-0051-01	
	672-0051-02	B080000		1						CKT BOARD ASSY:ATTENUATOR/READOUT	80009	672-0051-02	
	-----			-						. EACH CKT BOARD ASSY INCLUDES:			
-31	-----			1						. CKT BOARD ASSY:ATTENUATOR(SEE A1 EPL)			
-32	129-0299-00			4						. . POST,ELEC-MECH:HEX,0.333 INCH LONG	80009	129-0299-00	
										(ATTACHING PARTS FOR EACH)			
-33	210-0004-00			1						. . WASHER,LOCK:INTL,0.12 ID X 0.26"OD,STL	78189	1204-00-00-0541C	
	210-0406-00			1						. . NUT,PLAIN,HEX.:4-40 X 0.188 INCH,BRS	73743	2X12161-402	
										- - - * - - -			
-34	131-1030-00			10						. . CONTACT ASSY,EL:CAM SWITCH,BOTTOM	80009	131-1030-00	
-35	131-1031-00			10						. . CONTACT ASSY,EL:CAM SWITCH,TOP	80009	131-1031-00	
-36	210-0799-00			10						. . EYELET,MET:0.183 X 0.362 W			

Mechanical Parts List—7A16A

FIGURE 1 EXPLODED (CONT)

Fig. & Index No.	Tektronix Part No.	Serial/Model No. Eff	Dscnt	Qty	Name & Description					Mfr Code	Mfr Part Number
					1	2	3	4	5		
1-37	136-0252-01			14	00779	1-332095-2
	136-0333-00			2	00779	1-331677-4
-38	337-1406-00			1	80009	337-1406-00
-39	131-0707-00			2	22526	47439
-40	352-0169-00			1	80009	352-0169-00
-41	175-0825-00			FT	23499	TEK-175-0825-00
					(ATTACHING PARTS FOR CKT BD)						
-42	211-0001-00			3	83385	OB
-43	210-0053-00			3	83385	OB
-44	210-0405-00			3	73743	2X12157-402
					- - - * - - -						
-45	441-1097-00			1	80009	441-1097-00
					(ATTACHING PARTS)						
-46	211-0097-00			2	83385	OB
-47	210-0004-00			2	78189	1204-00-00-0541C
	210-0406-00			2	73743	2X12161-402
					- - - * - - -						
-48	131-0907-00			2	80009	131-0907-00
-49	105-0243-00			1	80009	105-0243-00
					(ATTACHING PARTS)						
-50	213-0214-00			1	70278	OB
					- - - * - - -						
	263-1018-00	XB060000	B079999	1	80009	263-1018-00
	263-1018-01	B080000		1	80009	263-1018-01
-51	354-0391-00	B010100	B059999	2	97464	3100-43-CD
	354-0390-00	B060000		1		
	354-0443-00	B060000		1		
-52	131-0963-00			2	80009	131-0963-00
-53	401-0081-02	B010100	B059999	2	80009	401-0081-02
	401-0180-00	B060000	B079999	2	80009	401-0180-00
	401-0180-02	B080000		1	80009	401-0180-02
	401-0180-01	B080000		1	80009	401-0180-01
					(ATTACHING PARTS)						
-54	211-0116-00			2	83385	OB
-55	210-0406-00			2	73743	2X12161-402
					- - - * - - -						
-56	214-1139-00			-	80009	214-1139-00
	214-1139-02			-	80009	214-1139-02
	214-1139-03			-	80009	214-1139-03
-57	214-1127-00	B010100	B059999	4	80009	214-1127-00
	214-1752-00	B060000		4	80009	214-1752-00
-58	105-0397-00	B010100	B059999	1	80009	105-0397-00
	105-0397-01	B060000		1	80009	105-0397-01
-59	401-0115-00	B010100	B059999	1	80009	401-0115-00
	401-0178-00	B060000		1	80009	105-0178-00
					(ATTACHING PARTS)						
	211-0116-00			2	83385	OB
	210-0406-00			2	73743	2X12161-402
					- - - * - - -						
-60	105-0398-00	B010100	B059999	1	80009	105-0398-00
	105-0398-01	B060000		1	80009	105-0398-01
	384-0880-00	XB060000		1	80009	384-0880-00
	384-0878-01	XB060000		1	80009	384-0878-01
-61	337-1754-00			1	80009	337-1754-00
					(ATTACHING PARTS)						
-62	213-0120-00			3	83385	OB
-63	210-0053-00			3	83385	OB
-64	210-1008-00			3	12360	OB
					- - - * - - -						
-65	-----			1		
-66	131-1031-00			7	80009	131-1031-00
	210-0779-00			7	42838	RA-29952715
					22526	75060
-67	136-0252-04	B010100	B061916	3	80009	136-0350-00
	136-0350-00	B061917		1		
					(ATTACHING PARTS FOR CKT BD)						
-68	211-0008-00			1	83385	OB
					- - - * - - -						

Mechanical Parts List—7A16A

FIGURE 1 EXPLODED (CONT)

Fig. & Index No.	Tektronix Part No.	Serial/Model No. Eff	Model No. Dscont	Qty	1 2 3 4 5	Name & Description	Mfr Code	Mfr Part Number
1-69	337-1418-01			1	.	SHIELD,ELEC:CAM SWITCH (ATTACHING PARTS)	80009	337-1418-01
-70	213-0277-00			3	.	SCR,TPG,THD FOR:2-56 X 0.312 INCH,PNH STL	83385	NOTE
-71	210-0053-00			3	.	WASHER,LOCK:INTL,0.092 ID X 0.175"OD,STL	83385	OBD
-72	210-1008-00			3	.	WASHER,FLAT:0.09 ID X 0.188" OD,BRS - - - * - - -	12360	OBD
-73	-----			1		CKT BOARD ASSY:AMPLIFIER(SEE A2 EPL)		
-74	131-0566-00			5	.	LINK,TERM.CONNE:0.086 DIA X 2.375 INCH L	0000C	L-2007-1
-75	136-0252-04	B010100	B041100	110	.	CONTACT,ELEC:0.188 INCH LONG	22526	75060
	136-0254-04	B041101		80	.	CONTACT,ELEC:0.188 INCH LONG	22526	75060
	136-0350-00	B041101		10	.	SKT,PL-IN ELEC:3 PIN,LOW PROFILE	80009	136-0350-00
-76	214-0579-00			1	.	TERM.,TEST PT:0.40 INCH LONG	80009	214-0579-00
-77	131-0608-00			2	.	CONTACT,ELEC:0.365 INCH LONG	22526	47357
-78	-----			1	.	RESISTOR,VAR:(SEE R516 EPL) (ATTACHING PARTS)		
-79	210-0583-00			1	.	NUT,PLAIN,HEX.:0.25-32 X 0.312 INCH,BRS	73743	2X20319-402
-80	210-0046-00			1	.	WASHER,LOCK:INTL,0.26 ID X 0.40" OD,STL - - - * - - -	78189	1214-05-00-0541C
-81	-----			1	.	RESISTOR,VAR:(SEE R515/S515 EPL) (ATTACHING PARTS)		
-82	210-0583-00			1	.	NUT,PLAIN,HEX.:0.25-32 X 0.312 INCH,BRS	73743	2X20319-402
-83	210-0046-00			1	.	WASHER,LOCK:INTL,0.26 ID X 0.40" OD,STL - - - * - - -	78189	1214-05-00-0541C
-84	211-0008-00			2		SCREW,MACHINE:4-40 X 0.25 INCH,PNH STL (ATTACHING PARTS FOR CKT BD) - - - * - - -	83385	OBD
-85	376-0029-00			2		CPLG,SHAFT,RGD:0.128 ID X 0.312 OD X 0.5"L	80009	376-0029-00
	213-0075-00			2	.	SETSCREW:4-40 X 0.094 INCH,HEX SOC STL	70276	OBD
-86	384-1111-00			1		EXTENSION SHAFT:7.04 L X 0.123 INCH OD	80009	384-1111-00
-87	384-1112-00			1	.	EXTENSION SHAFT:0.126ID X 0.125OD X 0.50L	80009	384-1112-00
-88	129-0080-00			1		POST,ELEC-MECH: (ATTACHING PARTS)	80009	129-0080-00
	211-0008-00			1		SCREW,MACHINE:4-40 X 0.25 INCH,PNH STL - - - * - - -	83385	OBD
-89	105-0075-00			1		PAWL:0.475 X 0.21 X 0.184 INCH,PLSTC	80009	105-0075-00
-90	214-1054-00			1		SPRING,DETENT:LATCH	80009	214-1054-00
-91	210-0288-00			1		TERMINAL,LUG: (ATTACHING PARTS)	80009	210-0288-00
-92	211-0105-00			1		SCREW,MACHINE:4-40 X 0.188"100 DEG,FLH STL	83385	OBD
-93	210-0586-00			1		NUT,PLAIN,EXT W:4-40 X 0.25 INCH,STL - - - * - - -	78189	OBD
-94	220-0547-01			4		NUT,BLOCK:0.38 X 0.25 X 0.282"OA (ATTACHING PARTS FOR EACH)	80009	220-0547-01
-95	211-0105-00			1		SCREW,MACHINE:4-40 X 0.188"100 DEG,FLH STL - - - * - - -	83385	OBD
-96	386-1402-00			1		PANEL,REAR: (ATTACHING PARTS)	80009	386-1402-00
-97	213-0192-00			4		SCR,TPG,THD FOR:6-32 X 0.50 INCH,PNH STL	87308	OBD
-98	361-0326-00			1		SPACER,SLEEVE:0.18 ID X 0.25 OD X 0.10"L - - - * - - -	80009	361-0326-00
-99	426-0737-00			1		FR SECT,PLUG-IN:BOTTOM	80009	426-0737-00
-100	214-1061-00			1		SPRING,GROUND:FLAT	80009	214-1061-00
-101	426-0736-00			1		FR SECT,PLUG-IN:TOP	80009	426-0736-00
-102	337-1064-04			2		SHIELD,ELEC:SIDE	80009	337-1064-00
-103	175-0825-00			FT		WIRE,ELECTRICAL:2 WIRE RIBBON	23499	TEK-175-0825-00
-104	175-0831-00			FT		WIRE,ELECTRICAL:8 WIRE RIBBON	08261	TEK-175-0831-00
-105	175-0832-00			FT		WIRE,ELECTRICAL:9 WIRE RIBBON	23499	TEK-175-0832-00
	210-0203-00	XB040000		1		TERMINAL,LUG: (ATTACHING PARTS)	78189	2103-06-00-2520N
	211-0105-00	XB040000		1		SCREW,MACHINE:4-40 X 0.188"100 DEG,FLH STL	83385	OBD
	210-0406-00	XB040000		1		NUT,PLAIN,HEX.:4-40 X 0.188 INCH,BRS - - - * - - -	73743	2X12161-402

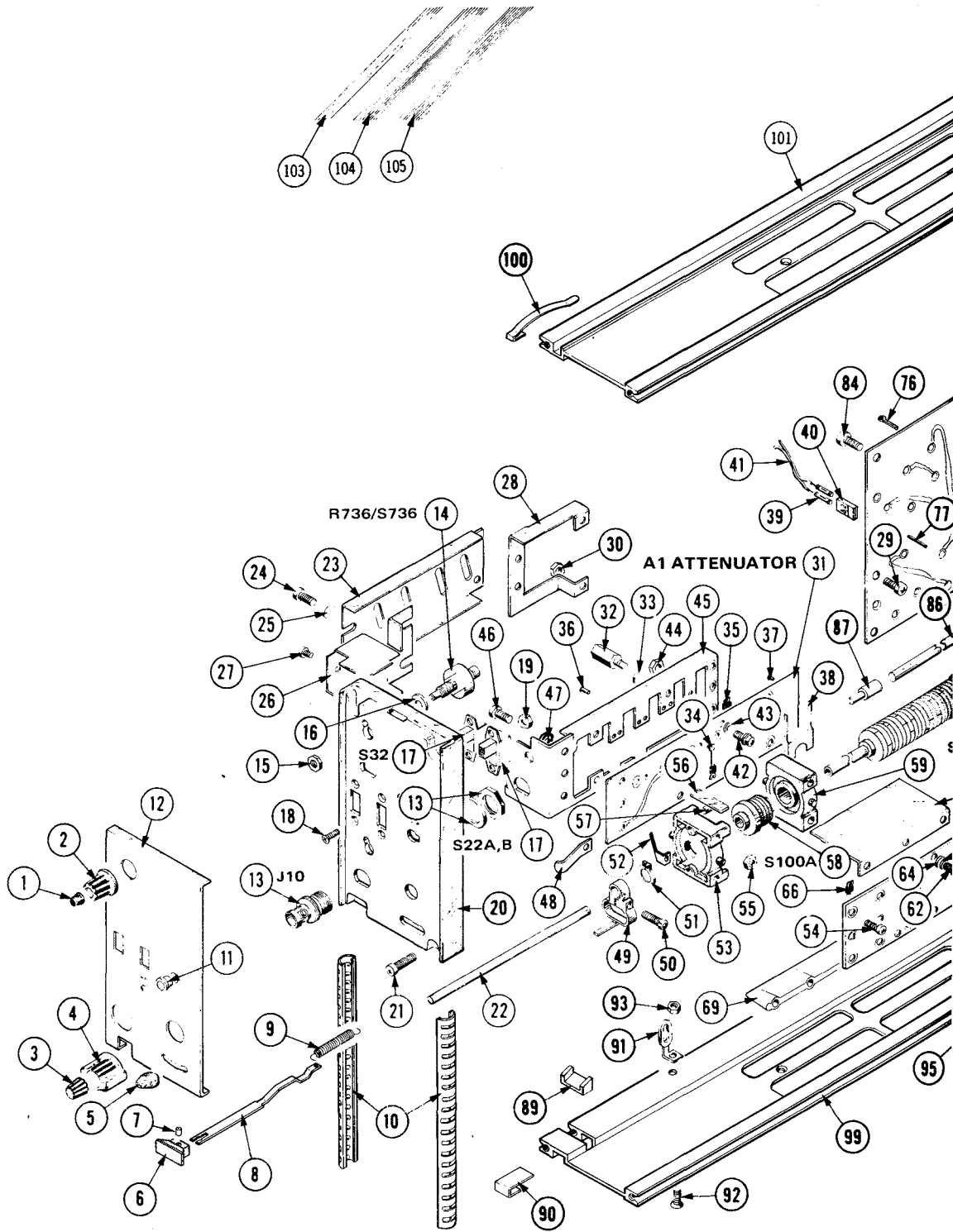

+

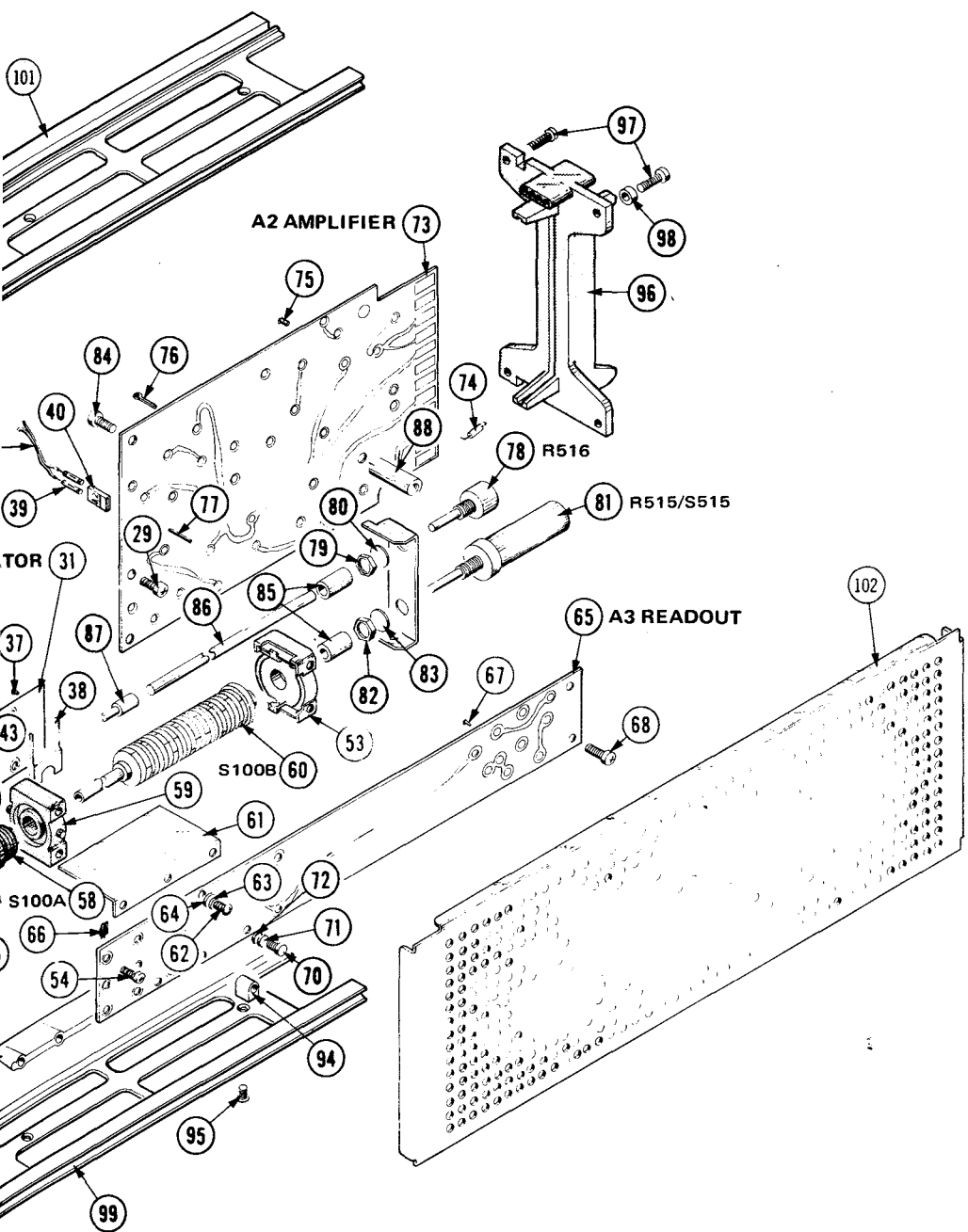

7A16A AMPLIFIER

+

ACCESSORIES

Fig. & Index No.	Tektronix Part No.	Serial/Model No.		Q t y						Description
		Eff	Disc		1	2	3	4	5	
2-	070-1378-00			1						MANUAL, instruction (not shown)

7A16A AMPLIFIER

REPACKAGING

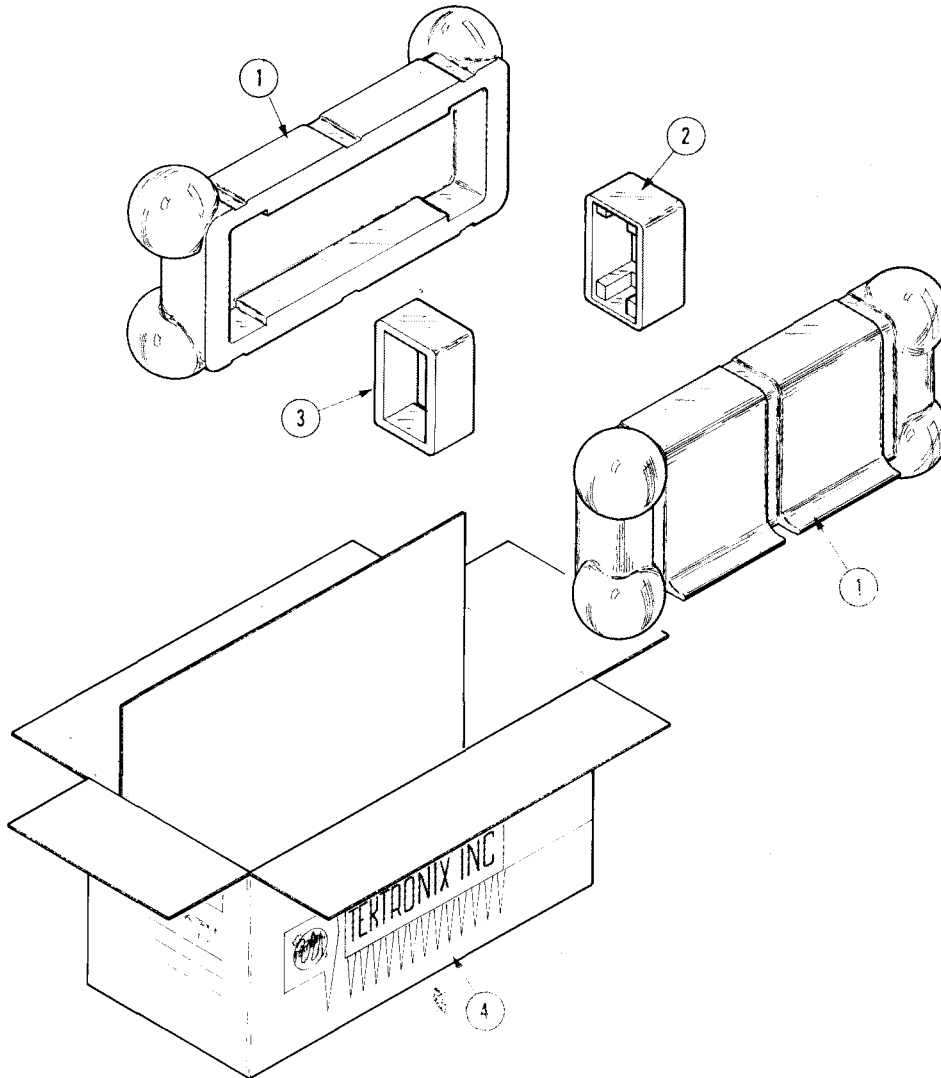

**Fig. &
Index
No.**

**Tektronix
Part No.**

**Serial/Model No.
Eff Disc**

**Q
t
y**

1 2 3 4 5

Description

2-	065-0125-00			1	CARTON ASSEMBLY
	-----			-	Carton assembly includes:
-1	004-0241-00			2	CASE HALF
-2	004-0242-00			1	END CAP, rear
-3	004-0243-00			1	END CAP, front
-4	004-0748-00			1	CARTON

MANUAL CHANGE INFORMATION

At Tektronix, we continually strive to keep up with latest electronic developments by adding circuit and component improvements to our instruments as soon as they are developed and tested.

Sometimes, due to printing and shipping requirements, we can't get these changes immediately into printed manuals. Hence, your manual may contain new change information on following pages.

A single change may affect several sections. Sections of the manual are often printed at different times, so some of the information on the change pages may already be in your manual. Since the change information sheets are carried in the manual until ALL changes are permanently entered, some duplication may occur. If no such change pages appear in this section, your manual is correct as printed.

Scans By *Artek Media*

Artek Media
1042 Plummer Cir. SW
Rochester, MN 55902

Manuals@artekmedia.com

"High resolution scans of obsolete technical manuals"

If you purchased this manual from us (typically through our Ebay name of NR1DX) thank you very much. If you received this from a well-meaning "friend" for free we would appreciate your treating this much like you would "share ware". By that we mean a donation of at least \$5-10 per manual is appreciated in recognition of the time, energy and quality of effort that went into preserving this manual. Donations via PayPal go to: manuals@artekmedia.com or can be mailed to us the address above. This is not a hobby for us but a semi-retirement business used to augment our diminished income in the face of the current degraded world economy.

Typically the scans in our manuals are done as follows;

- 1) Typed text pages are typically scanned in black and white at 300 dpi.
- 2) Photo pages are typically scanned in gray scale mode at 600 dpi
- 3) Schematic diagram pages are typically scanned in black and white at 600 dpi unless the original manual had colored high lighting (as is the case for some 70's vintage Tektronix manuals).

Original pages, which exceed the 8.5 x 11 format, are scanned with enough overlap so that they can be printed and pieced. This is done for primarily for two reasons, the time involved in post processing these to their original size is not trivial and most people do not have the ability to print 11 X 17 pages anyway.

If your looking for a quality scanned technical manual in PDF format please drop us a line at manuals@artekmedia.com and we will be happy to email you a current list of the manuals we have available. If you don't see the manual you need on the list drop us a line anyway we may still be able to point you to other sources. If you have an existing manual you would like scanned please write for details, This can often be done very reasonably in consideration for adding your manual to our library.

Thanks

Dave & Lynn Henderson
Artek Media