



**PLEASE CHECK FOR CHANGE INFORMATION
AT THE REAR OF THIS MANUAL.**

7A17

AMPLIFIER

INSTRUCTION MANUAL

Tektronix, Inc.
P.O. Box 500
Beaverton, Oregon 97077

070-1263-00
Product Group 42

Scans by ARTEK MEDIA =>

Serial Number _____

First Printing OCT 1971
Revised APR 1984

Scans By *Artek Media*

Artek Media
1042 Plummer Cir. SW
Rochester, MN 55902

www.artekmedia.com

"High resolution scans of obsolete technical manuals"

If your looking for a quality scanned technical manual in PDF format please visit our WEB site at www.artekmedia.com or drop us an email at manuals@artekmedia.com and we will be happy to email you a current list of the manuals we have available.

If you don't see the manual you need on the list drop us a line anyway we may still be able to point you to other sources. If you have an existing manual you would like scanned please write for details, This can often be done very reasonably in consideration for adding your manual to our library.

Typically the scans in our manuals are done as follows;

- 1) Typed text pages are typically scanned in black and white at 300 dpi.
- 2) Photo pages are typically scanned in gray scale mode at 600 dpi
- 3) Schematic diagram pages are typically scanned in black and white at 600 dpi unless the original manual had colored high lighting (as is the case for some 70's vintage Tektronix manuals).

If you purchased this manual from us (typically through our Ebay name of ArtekMedia) thank you very much. If you received this from a well-meaning "friend" for free we would appreciate your treating this much like you would "share ware". By that we mean a donation of at least \$5-10 per manual is appreciated in recognition of the time (a manual can take as much as 40 hours to reproduce, book, link etc.), energy and quality of effort that went into preserving this manual. Donations via PayPal go to: manuals@artekmedia.com or can be mailed to us the address above.

Thanks

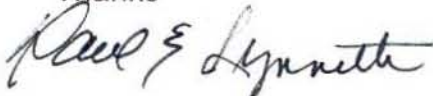

Dave & Lynn Henderson
Artek Media

Copyright © 1971 Tektronix, Inc. All rights reserved.
Contents of this publication may not be reproduced in any
form without the written permission of Tektronix, Inc.

Products of Tektronix, Inc. and its subsidiaries are covered
by U.S. and foreign patents and/or pending patents.

TEKTRONIX, TEK, SCOPE-MOBILE, and  are
registered trademarks of Tektronix, Inc. TELEQUIPMENT
is a registered trademark of Tektronix U.K. Limited.

Printed in U.S.A. Specification and price change privileges
are reserved.

INSTRUMENT SERIAL NUMBERS

Each instrument has a serial number on a panel insert, tag,
or stamped on the chassis. The first number or letter
designates the country of manufacture. The last five digits
of the serial number are assigned sequentially and are
unique to each instrument. Those manufactured in the
United States have six unique digits. The country of
manufacture is identified as follows:

B000000	Tektronix, Inc., Beaverton, Oregon, USA
100000	Tektronix Guernsey, Ltd., Channel Islands
200000	Tektronix United Kingdom, Ltd., London
300000	Sony/Tektronix, Japan
700000	Tektronix Holland, NV, Heerenveen, The Netherlands

TABLE OF CONTENTS

	Page
SPECIFICATION	1
OPERATING INSTRUCTIONS	1
CIRCUIT OPERATION	1
MAINTENANCE	2
CALIBRATION	2
APPLICATIONS	3
ELECTRICAL PARTS LIST	
DIAGRAMS AND CIRCUIT BOARD ILLUSTRATIONS	
MECHANICAL PARTS LIST	

7A17



ADD OCT 1983

7A17 INSTRUCTION MANUAL

SPECIFICATION

General

The 7A17 is a utility plug-in designed for use with Tektronix 7000-series oscilloscopes. This plug-in provides 50-ohm, 50-millivolt/division access to either the vertical or horizontal deflection system in the mainframe. It also provides interfacing to the mainframe power supplies, readout encoding circuits, and other functions that allow custom circuit design to meet specific needs.

Electrical Characteristics

Deflection Factor:

50 millivolts/division with Gain adjusted internally.

Frequency Response (Mainframe dependent):

7400 - 50 megahertz; 7500 - 75 megahertz; 7700 - 150 megahertz; 7900 - greater than 150 megahertz.

Input Impedance:

50 ohms plus or minus 10%.

POSITION Range:

At least +10 divisions to at least -10 divisions from graticule center.

Maximum Input Voltage:

5 volts RMS

Environmental Characteristics

Refer to the 7000-series oscilloscope mainframe manual.

OPERATING INSTRUCTIONS

General

The 7A17 operates with any 7000-series oscilloscope and is ready for use as it is received. It can be installed in any compartment of the 7000-series oscilloscope. To

install, align the upper and lower rails of the 7A17 with the plug-in compartment tracks and fully insert it (the plug-in panel must be flush with the oscilloscope panel). To remove, pull the release latch to disengage the 7A17 from the oscilloscope.

Controls and Connectors

POSITION	Positions the display.
INPUT	BNC connector provides a means for connecting a signal.

Input Coupling

The 7A17 INPUT is directly coupled into a 50-ohm impedance. However, the input may be designed to accept any type of signal. Refer to the Applications section for suggestions.

Deflection Factor

This plug-in has a basic deflection factor of 50 mV/div when the internal Gain control is properly adjusted. Greater than 10 mV/div at reduced bandwidth may be achieved by adjusting the Gain control. Other deflection factors may be achieved by using the solder pads provided in the plug-in, and custom-designing the circuit. Refer to the Applications section for suggestions.

Readout Encoding

The 7A17 is not factory equipped with readout. However, access is provided so that readout encoding resistors can be connected. Refer to the Applications section for suggestions.

Polarity

The polarity of the displayed signal may be inverted by moving the straps from +UP (as marked on the circuit board) to the solder pads marked INV.

CIRCUIT OPERATION

The signal applied to the INPUT connector is direct coupled to paraphase amplifier Q110, Q210. Positioning is achieved by varying the DC level at the base of Q210. Gain of the paraphase amplifier (Q110, Q210) is

7A17

set to approximately one by R211. Polarity of the displayed signal may be inverted by moving the shorting straps to the INV position. The output of the paraphase amplifier is connected to common emitter differential amplifier Q125, Q225 and common base differential amplifier Q120, Q220. These amplifiers provide trigger output and signal outputs to the oscilloscope mainframe via the interface connectors.

MAINTENANCE

General

This portion of the manual contains information concerning preventive maintenance, corrective maintenance, and troubleshooting the 7A17. Further information relating to general maintenance can be found in the 7000-series instruction manual.

Cleaning

To improve reliability and to avoid possible thermal and electrical problems, it is recommended that the 7A17 be cleaned at periodic intervals, as well as before calibration.

Loose dust may be removed with a soft cloth or a dry brush. Hardened dirt may be removed with a cotton-tipped swab or cloth, dampened with a mild detergent and water solution, then carefully rinsed and dried.

Troubleshooting

Several troubleshooting aids for the 7A17 are given on one foldout page located at the rear of the manual. This page includes: Schematic diagrams, showing important voltages, component values, and circuit numbers; board pictures showing physical locations of the components; and semiconductor basing diagrams. For best results, use these aids in conjunction with the Circuit Operation and Calibration procedure.

Refer to the 7000-series mainframe manual for general troubleshooting information. (i.e. semiconductor care, color coding, etc.).

Corrective Maintenance

Standard Replacement Parts. All electrical and mechanical replacement parts for the 7A17 can be obtained through your local field office or representative. However, many of the electronic parts can be obtained locally in less time than is required to order them from Tektronix, Inc. Before purchasing or ordering replacement parts, check the parts list for value, rating, tolerance, and description.

Special Parts. In addition to the standard electronic components, some special parts are used in the 7A17. These parts are manufactured or selected by Tektronix, Inc. in accordance with our specifications. These special parts are indicated in the parts list by an asterisk preceding the part number. Order all special parts directly from your local Tektronix Field Office or representative.

Ordering Parts. When ordering replacement parts from Tektronix, Inc., include the instrument Type, instrument Serial Number, a description of the part (if electrical, include circuit number), and the Tektronix Part Number.

Soldering Techniques. Care should be taken when soldering to prevent damage due to excess heat. A small wattage soldering iron (15 to 50 watts) should be used. Apply heat directly to the junction to be soldered. Use only enough heat to form a good bond. Heat sink components when necessary.

Repackaging for Shipment

If the Tektronix instrument is to be shipped to a Tektronix Service Center for service or repair, attach a tag showing: owner (with address) and the name of an individual at your firm that can be contacted, complete instrument serial number and a description of the service required.

Save and re-use the package in which your instrument was shipped. If the original packaging is unfit for use or not available, repackage the instrument as follows:

Surround the instrument with polyethylene sheeting to protect the finish of the instrument. Obtain a carton of corrugated cardboard of the correct carton strength and having inside dimensions of no less than six inches more than the instrument dimensions. Cushion the instrument by tightly packing three inches of dunnage or urethane foam between carton and instrument, on all sides. Seal carton with shipping tape or industrial stapler.

The carton test strength for your instrument is 200 pounds.

CALIBRATION

Gain

Install the 7A17 in any 7000-series oscilloscope mainframe. Apply a 1 kHz, 0.4 volt square-wave from the oscilloscope CALIBRATOR. Center the display and adjust the Gain potentiometer (located on the circuit board) for a display of eight divisions.

NOTE

Observe proper termination of CALIBRATOR output when applying voltage to the 7A17 50 Ω input.

APPLICATIONS

General

This section provides suggestions for possible modifications to the 7A17. The 7A17 may be modified to suit a particular need by using the areas provided for circuit construction. Power supply and readout connections are readily available; see Fig. 2 for their locations. The front sub-panel of the 7A17 is pre-punched with various size and shape holes to allow easy mounting of switches, indicators, etc.

Power supply limitations are given in Table 1. It is recommended that circuitry added to the 7A17 not exceed these limitations.

TABLE 1

POWER SUPPLY LOAD LIMITS

Supply Volts	*Maximum Limit
+5 V	500 mA
+15 V	500 mA
-15 V	500 mA
+50 V	100 mA
-50 V	100 mA

*These maximums cannot occur simultaneously! The total power dissipation must not exceed 16.5 watts.

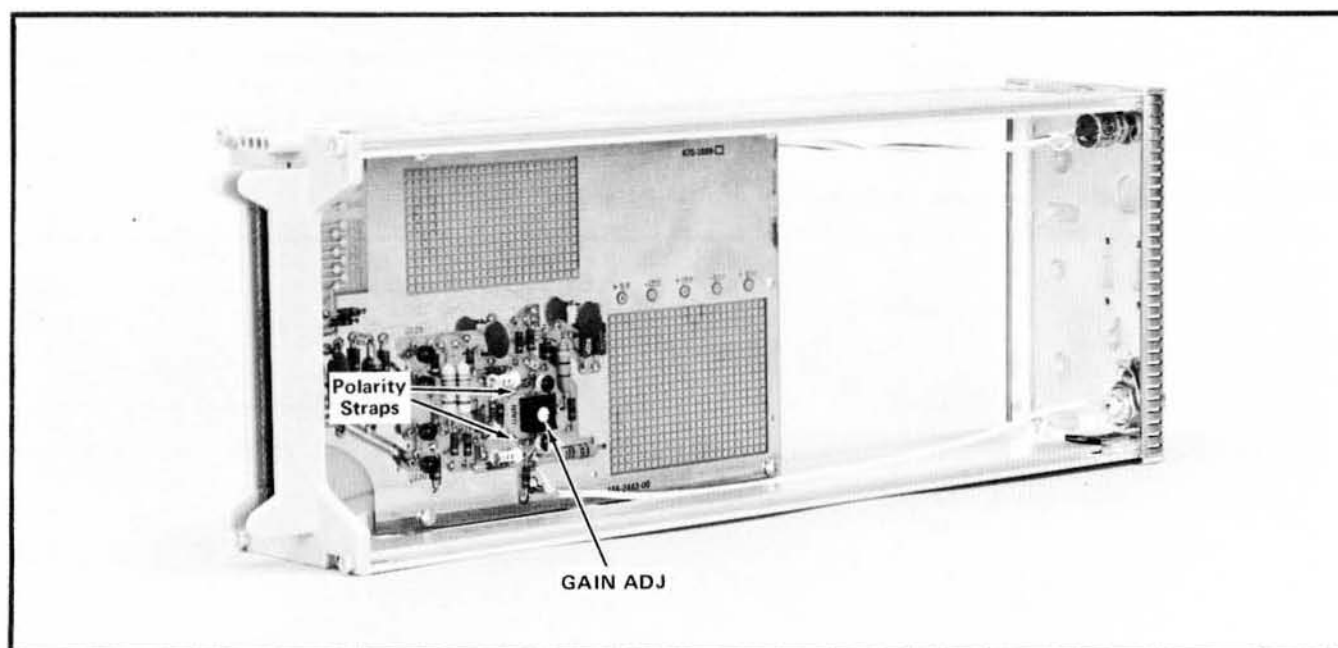

Fig. 2. 7A17 showing areas for circuit construction and pre-punched front sub-panel.

HIGH IMPEDANCE AMPLIFIER

This field effect transistor (FET) amplifier can be connected to the input of the 7A17 to increase the stability and raise the input impedance from 50 ohms to over one megohm depending on the value of R1. (It is not recommended that R1 exceed five or ten megohms due to potential leakage problems.)

The optional limiter circuit, consisting of CR1a and CR1b, should be used when there is a possibility of exceeding ± 15 volts at the input of the FET amplifier. This circuit will avoid possible damage to the FET.

Attenuators may be added to this amplifier circuit for the purpose of obtaining a desired deflection factor, refer to the application for "attenuators".

Parts List:

*R1	1 M Ω	1/4 W	1/2%
R2	470 K Ω	1/4 W	10%
R3	560 Ω	1/4 W	5%
R4	47 Ω	1/4 W	10%

*May be selected to suit input impedance requirements.

R5	390 Ω	1/4 W	5%
R6	910 Ω	1/4 W	5%
R7	21 Ω	1/8 W	1%
R8	1 M Ω	1/4 W	10%
R9	21 Ω	1/8 W	1%
R10	910 Ω	1/4 W	5%
R11	390 Ω	1/4 W	5%

C1	.005 μ F	cer	20%	500 V
C2	1.8 pF	cer	20%	500 V
C3	22 μ F	elect	20%	15 V
C4	.001 μ F	cer	20%	500 V
C5	22 μ F	elect	20%	15 V

Q1_a - Q1_b

N channel Dual FET 2N4416 available from Tektronix, Inc., order part number 151-1031-00.

**D1_a - D1_b

Dual diode FSA1480 available from Tektronix, Inc., order part number 152-0321-00.

**Optional

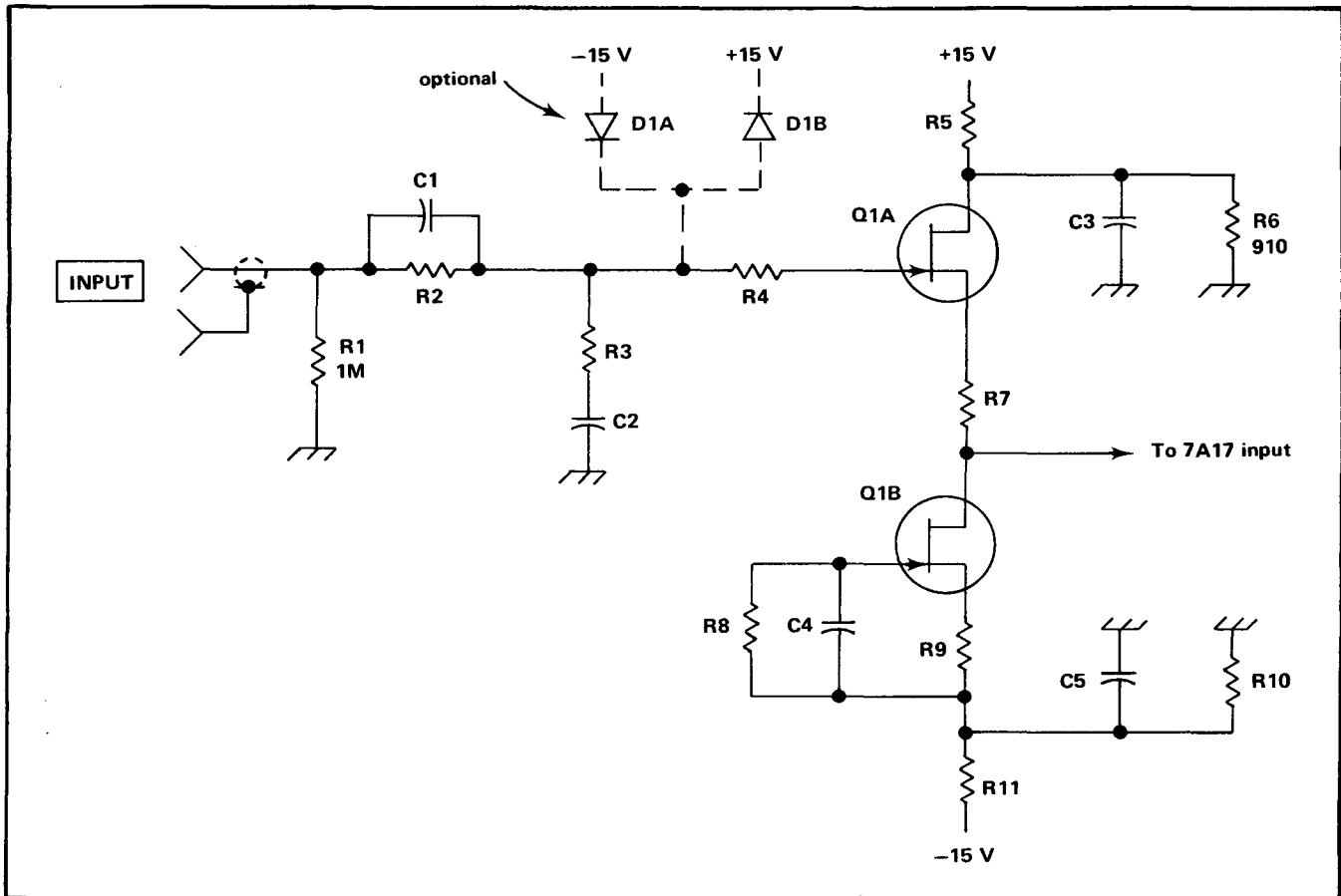

Fig. 3. FET Amplifier.

ATTENUATORS (Use with FET Amplifier)

In some cases where the sensitivity of the 7A17 is too great, attenuators of the type shown in Fig. 4 may be added. These are high impedance attenuators and should be used with a high input impedance amplifier, refer to the FET Amplifier in this section.

C2 is a variable capacitor used to normalize the Input to approximately 10 pF. For these calculations, C2 is assumed to be 10 pF.

Formulas:

$$\text{Attenuation Ratio } V_r = V_o/V_i$$

R_{fet} = input resistance of the amplifier.

R_{in} = desired input resistance at the INPUT connector.

$$R_2' = R_{in} \times V_r \quad R_2 \text{ paralleled with } R_{fet}$$

$$R_1 = R_{in} - R_2'$$

$$R_2 = \frac{R_2' R_{fet}}{R_{fet} - R_2'}$$

$$C_1 = \frac{R_2' C_2}{R_1}$$

Example: A deflection factor of 200 mV/div with $R_{in} = 1$ megohm is desired. The FET amplifier has an input resistance = 1 megohm = R_{fet}

$$V_r = V_o/V_i = \frac{50 \text{ mV/div}}{200 \text{ mV/Div}} = 0.25$$

$$R_2' = 1 \text{ megohm} \times 0.25 = 250 \text{ kilohm}$$

$$R_1 = 1 \text{ megohm} - 250 \text{ kilohm} = 750 \text{ kilohm}$$

$$R_2 = \frac{250 \text{ kilohm} \times 1 \text{ megohm}}{1 \text{ megohm} - 250 \text{ kilohm}} = 333 \text{ kilohm}$$

$$C_1 = \frac{250 \text{ kilohm} \times 10 \text{ picofarads}}{750 \text{ kilohm}} = 3.3 \text{ picofarads}$$

Normalizing

Connect a 1 kHz square wave from the oscilloscope CALIBRATOR. Adjust the output of the CALIBRATOR for a display of four to six vertical divisions. Adjust C2 for square leading edge and flat top.

Gain

Readjust, if necessary, the 7A17 Gain control for proper sensitivity.

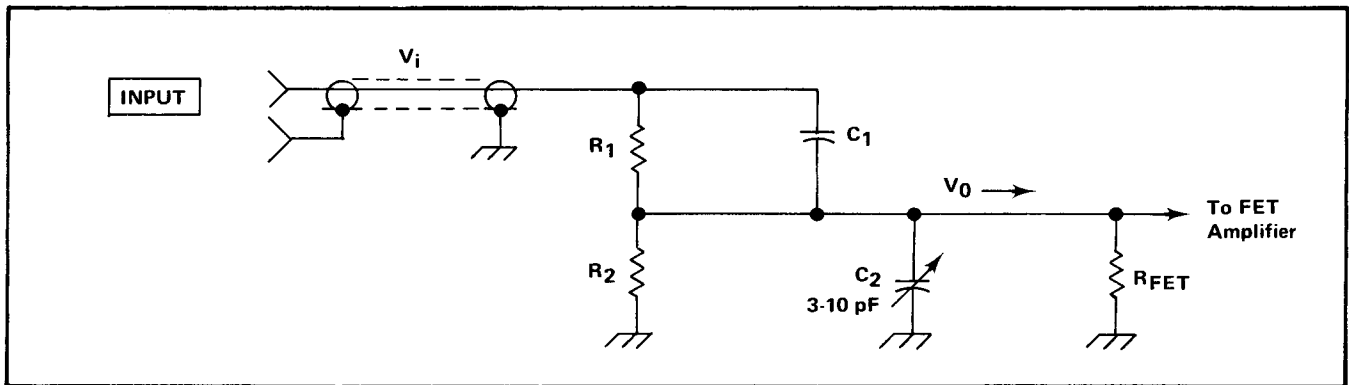

Fig. 4. High Frequency Attenuators.

READOUT

Each of the oscilloscopes four plug-in compartments are allotted two word locations located at the top and bottom of the CRT screen (see Fig. 5). Each word location can be encoded to write up to ten characters. For each of the ten spaces available in a word location there is a corresponding timeslot (TS) pulse. The timeslot pulses interrogate the readout encoding resistors in the plug-ins. The resulting information is returned to the oscilloscope readout system as various row and column currents. These row and column currents select the characters or operations from the matrix shown in Fig. 7. For example: to obtain the letter "A" there must be 0.4 mA of row current and 0.3 mA of column current.

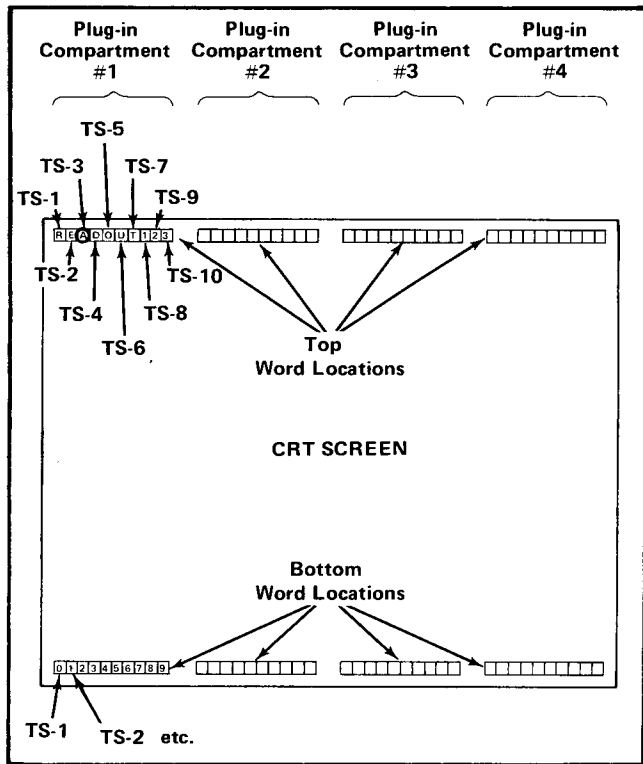

Fig. 5. Readout Word Locations and Timeslot Locations.

Each word location has its own row and column return lines. The top word locations have a row return line located at B37 of the plug-in interface connector and a column return line located at A37. The bottom word locations have a row return line at B38 and a column return line at A38.

The timeslot pulses are always -15 volts in amplitude. Therefore the current flowing from the timeslot lines through the plug-in encoding resistors into the row and column return lines is a direct result of the value of the encoding resistors as given by Ohm's law. For example: In order to place the letter "A" at timeslot location 3 of the top word location (circled in Fig. 5), a 37.4 kilohm resistor (-15 volts/0.4 mA) must be placed between TS-3 and the row return line B37 and a 50 kilohm resistor (-15 volts/0.3 mA) between TS-3 and column return line A37. Refer to Table 2 for interface pin connections.

The diagram for the above example is shown in Fig. 6.

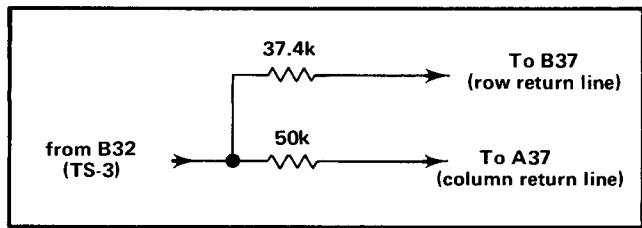

Fig. 6. Encoding configuration for letter "A".

To assure that encoding errors cannot occur when the encoding load is heavy, a diode should be placed in series with those encoding resistors that allow 0.6 mA or more current to flow into the row or column return lines. This means that when calculating the values for the encoding resistors the forward voltage drop (V_f) of the diode must be taken into account; i.e., to obtain 0.9 mA using a silicon diode, the typical value of the encoding resistor would be $-15 \text{ volts } V_f / 0.9 \text{ mA} = 15 \text{ volts} - 0.6 \text{ volts} / 0.9 \text{ mA} \approx 16.2 \text{ kilohms}$.

TABLE 2

Timeslot Number	Interface Pin Number	
- TS-1	B33	} Encoding Resistors {
- TS-2	A33	
- TS-3	B32	
- TS-4	A32	
- TS-5	B31	
- TS-6	A31	
- TS-7	B30	
- TS-8	A30	
- TS-9	B29	
- TS-10	A29	

Row Return Line B37	} for top word locations
Column Return Line A37	
Row Return Line B38	} for bottom word locations
Column Return Line A38	

Column	0	1	2	3	4	5	6	7	8	9	10
Current (Milli-amperes)	0	0.1	0.2	0.3	0.4	0.5	0.6	0.7	0.8	0.9	≥1.0
Row	0	0.1	0.2	0.3	0.4	0.5	0.6	0.7	0.8	0.9	≥1.0
1	0	0	1	2	3	4	5	6	7	8	9
2	0.1	/	<	I	/	+	-	+	C	Δ	>
3	0.2	Add* one zero	Add* two zeros	Reduce* prefix	Reduce* prefix and add one zero						IDENTIFY*
4	0.3	<i>m</i>	<i>μ</i>	<i>n</i>	<i>p</i>	<i>X</i>	<i>K</i>	<i>M</i>	<i>G</i>	<i>T</i>	<i>R</i>
5	0.4	<i>S</i>	<i>V</i>	<i>A</i>	<i>W</i>	<i>H</i>	<i>d</i>	<i>B</i>	<i>c</i>	<i>Ω</i>	<i>E</i>
6	0.5	<i>U</i>	<i>N</i>	<i>L</i>	<i>Z</i>	<i>Y</i>	<i>P</i>	<i>F</i>	<i>J</i>	<i>Q</i>	<i>D</i>
7	0.6			Decimal* point location #3	Decimal* point location #4	Decimal* point location #5	Decimal* point location #6	Decimal* point location #7			
8	0.7										
9	0.8										
10	0.9	Add Space In Display*									

* Operational address

Fig. 7. Readout Matrix.

The following table indicates the typical resistor values required to encode specific currents. Resistors may be rated as low as 1/8 watt.

Required Current	Resistor Value	Tolerance
0.1 mA	150 kΩ	5%
0.2 mA	75 kΩ	5%
0.3 mA	50 kΩ	5%
0.4 mA	37.4 kΩ	1%
0.5 mA	30.1 kΩ	1%
0.6 mA	24.3 kΩ	1%
*0.7 mA	20.5 kΩ	1%
*0.8 mA	18.2 kΩ	1%
*0.9 mA	16.2 kΩ	1%
*≥1.0 mA	12 kΩ	5%

*Using a 1N4152 silicon diode

Example: "TEST 1" is to be written on the CRT screen. This word is six characters long (including a

space). The following figure shows a possible timeslot assignment.

Timeslot	1	2	3	4	5	6	7	8	9	10
Character			T	E	S	T	space	1		

Timeslots 1, 2, 9 and 10 do not require encoding resistors. Typical resistor values for encoding are given in the following chart.

The circuit for "TEST 1" is shown in Fig. 8.

Timeslot Location	Character	Row Encoding Resistor	Column Encoding Resistor
3	T	50 kΩ	16.2 kΩ
4	E	37.4 kΩ	12 kΩ
5	S	37.4 kΩ	150 kΩ
6	T	50 kΩ	16.2 kΩ
7	SPACE	16.2 kΩ	—
8	1	—	75 kΩ

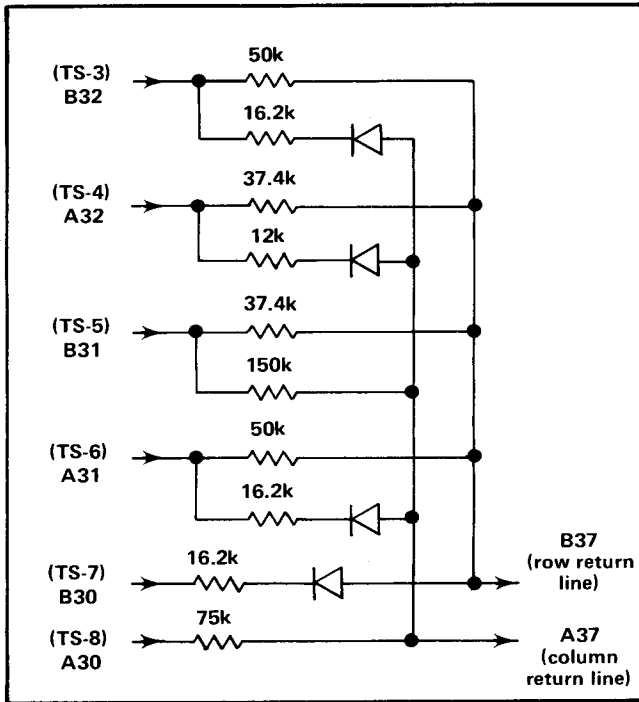

Fig. 8. Encoding information for "TEST 1".

The readout matrix (Fig. 7) contains both characters and operations. The operations are marked with an asterisk (*) and are always encoded during timeslot 1. Encoding these operations causes pre-determined characters or decimals to appear in or between pre-determined timeslot locations. For example: encoding "ADD TWO ZEROS" during timeslot 1 will cause zeros to be displayed in timeslot locations 5 and 6; by encoding "REDUCE PREFIX" during timeslot 1, the prefix that was previously encoded for timeslot 7 will be changed; (i.e., milli (m) to micro (μ)).

Decimals encoded during timeslot 1 appear between timeslot locations therefore do not require the use of another timeslot location. Example: Encoding "DECIMAL POINT LOCATION #4" during timeslot 1 would cause a decimal to appear between timeslot 4 and timeslot 5.

Encoding the "IDENTIFY" operation during timeslot 1 will cause the entire readout to change to the word IDENTIFY.

For further information concerning the readout refer to the manual of any 7000 series mainframe that contains a readout.

BANDWIDTH LIMITER

For low frequency applications, high frequency noise problems can be reduced by restricting the bandwidth of the 7A17. For example, when displaying a low-frequency signal, limiting the high frequency response in many cases will considerably reduce high frequency noise without distorting the desired signal.

The filter shown in Fig. 9 is to be connected in series with the Signal output lines (A-11 and B-11 on the connector). Small notches on the conductive "runs" leading to A-11 and B-11 are provided as points where the Signal output lines may be cut to insert the filter.

This filter may be designed using the following formula where F_c is the -3 dB frequency in Hertz (when working into an impedance of 50 ohms each side to ground). L is given in Henrys; C is given in Farads; and R is given in Ohms.

$$L = \frac{50}{\pi F_c} \quad C = \frac{L}{\pi F_c \times 200} \quad R = \frac{2\pi F_c L}{0.5}$$

EXAMPLE: When F_c equals 5 megahertz. $L = 3.20 \mu\text{H}$, $C = 320 \text{ pF}$, and $R = 200 \text{ ohms}$.

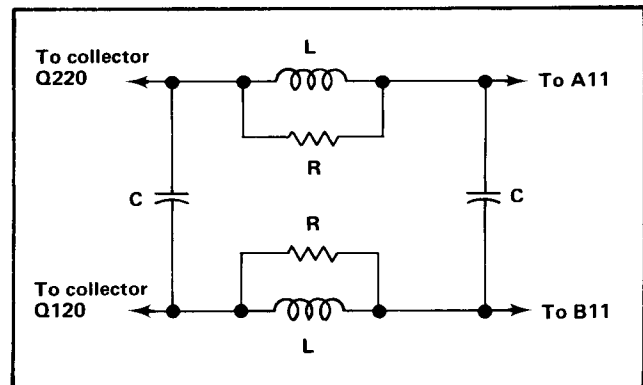

Fig. 9. Bandwidth Limiter.

REPLACEABLE ELECTRICAL PARTS

PARTS ORDERING INFORMATION

Replacement parts are available from or through your local Tektronix, Inc. Field Office or representative.

Changes to Tektronix instruments are sometimes made to accommodate improved components as they become available, and to give you the benefit of the latest circuit improvements developed in our engineering department. It is therefore important, when ordering parts, to include the following information in your order: Part number, instrument type or number, serial number, and modification number if applicable.

If a part you have ordered has been replaced with a new or improved part, your local Tektronix, Inc. Field Office or representative will contact you concerning any change in part number.

Change information, if any, is located at the rear of this manual.

ITEM NAME

In the Parts List, an Item Name is separated from the description by a colon (:). Because of space limitations, an Item Name may sometimes appear as incomplete. For further Item Name identification, the U.S. Federal Cataloging Handbook H6-1 can be utilized where possible.

ABBREVIATIONS

ACTR	ACTUATOR	PLSTC	PLASTIC
ASSY	ASSEMBLY	QTZ	QUARTZ
CAP	CAPACITOR	RECP	RECEPTACLE
CER	CERAMIC	RES	RESISTOR
CKT	CIRCUIT	RF	RADIO FREQUENCY
COMP	COMPOSITION	SEL	SELECTED
CONN	CONNECTOR	SEMICOND	SEMICONDUCTOR
ELCTLT	ELECTROLYTIC	SENS	SENSITIVE
ELEC	ELECTRICAL	VAR	VARIABLE
INCAND	INCANDESCENT	WW	WIREWOUND
LED	LIGHT EMITTING DIODE	XFMR	TRANSFORMER
NONWIR	NON WIREWOUND	XTAL	CRYSTAL

Replaceable Electrical Parts—7A17**CROSS INDEX—MFR. CODE NUMBER TO MANUFACTURER**

Mfr. Code	Manufacturer	Address	City, State, Zip
01121	ALLEN-BRADLEY COMPANY	1201 2ND STREET SOUTH	MILWAUKEE, WI 53204
04222	AVX CERAMICS, DIVISION OF AVX CORP.	P O BOX 867	MYRTLE BEACH, SC 29577
04713	MOTOROLA, INC., SEMICONDUCTOR PROD. DIV.	5005 E MCDOWELL RD, PO BOX 20923	PHOENIX, AZ 85036
07263	FAIRCHILD SEMICONDUCTOR, A DIV. OF FAIRCHILD CAMERA AND INSTRUMENT CORP.	464 ELLIS STREET	MOUNTAIN VIEW, CA 94042
24546	CORNING GLASS WORKS, ELECTRONIC COMPONENTS DIVISION	550 HIGH STREET	BRADFORD, PA 16701
32997	BOURNS, INC., TRIMPOT PRODUCTS DIV.	1200 COLUMBIA AVE.	RIVERSIDE, CA 92507
59660	TUSONIX INC.	2155 N FORBES BLVD	TUCSON, AZ 85705
59821	CENTRALAB INC SUB NORTH AMERICAN PHILIPS CORP	7158 MERCHANT AVE	EL PASO, TX 79915
77820	BENDIX CORP., THE, ELECTRICAL COMPONENTS DIVISION	SHERMAN AVE.	SIDNEY, NY 13838
80009	TEKTRONIX, INC.	P O BOX 500	BEAVERTON, OR 97077
91637	DALE ELECTRONICS, INC.	P. O. BOX 609	COLUMBUS, NE 68601

Replaceable Electrical Parts—7A17

Ckt No.	Tektronix Part No.	Serial/Model No. Eff	Dscont	Name & Description	Mfr Code	Mfr Part Number
A1	670-1899-00			CKT BOARD ASSY:AMPLIFIER	80009	670-1899-00
C112	281-0528-00			CAP.,FXD,CER DI:82PF,+/-8.2PF,500V	59660	301-000U2M0820K
C121	283-0002-00			CAP.,FXD,CER DI:0.01UF,+80-20%,500V	59821	SDDH69L103Z
C128	283-0002-00			CAP.,FXD,CER DI:0.01UF,+80-20%,500V	59821	SDDH69L103Z
C129	283-0078-00			CAP.,FXD,CER DI:0.001UF,20%,500V	59660	0801 547X5F0102M
C200	283-0032-00	B040000		CAP.,FXD,CER DI:470PF,5%,500V	59660	0831085Z5E00471J
C207	283-0002-00			CAP.,FXD,CER DI:0.01UF,+80-20%,500V	59821	SDDH69L103Z
C211	281-0593-00	B030000	B039999	CAP.,FXD,CER DI:3.9PF,10%,500V	04222	7001-C0J-3R9C
C212	281-0528-00			CAP.,FXD,CER DI:82PF,+/-8.2PF,500V	59660	301-000U2M0820K
J100	131-0126-00			CONNECTOR,RCPT,:BNC,FEMALE	77820	9663-1 NT-34
LR300	108-0184-00			COIL,RF:3.2UH(WOUND ON A 10 OHM RES	80009	108-0184-00
LR301	108-0184-00			COIL,RF:3.2UH(WOUND ON A 10 OHM RES	80009	108-0184-00
Q110	151-0259-00			TRANSISTOR:SILICON,NPN	07263	S39288
Q120	151-0221-00			TRANSISTOR:SILICON,PNP	04713	SPS246
Q125	151-0221-00			TRANSISTOR:SILICON,PNP	04713	SPS246
Q210	151-0259-00			TRANSISTOR:SILICON,NPN	07263	S39288
Q220	151-0221-00			TRANSISTOR:SILICON,PNP	04713	SPS246
Q225	151-0221-00			TRANSISTOR:SILICON,PNP	04713	SPS246
R100	323-0069-00			RES.,FXD,FILM:51.1 OHM,1%,0.50W	91637	MFF1226G51R10F
R105	315-0510-00			RES.,FXD,CMPSN:51 OHM,5%,0.25W	01121	CB5105
R110	315-0101-00			RES.,FXD,CMPSN:100 OHM,5%,0.25W	01121	CB1015
R111	323-0178-00			RES.,FXD,FILM:698 OHM,1%,0.50W	91637	MFF1226G698R0F
R112	315-0221-00			RES.,FXD,CMPSN:220 OHM,5%,0.25W	01121	CB2215
R113	315-0271-00			RES.,FXD,CMPSN:270 OHM,5%,0.25W	01121	CB2715
R120	323-0150-00			RES.,FXD,FILM:357 OHM,1%,0.50W	91637	MFF1226G357R0F
R121	315-0150-00			RES.,FXD,CMPSN:15 OHM,5%,0.25W	01121	CB1505
R122	315-0821-00			RES.,FXD,CMPSN:820 OHM,5%,0.25W	01121	CB8215
R123	323-0196-00			RES.,FXD,FILM:1.07K OHM,1%,0.50W	91637	CMF1418G10700F
R125	323-0101-00			RES.,FXD,FILM:110 OHM,1%,0.50W	24546	NA65D1100F
R126	315-0911-00			RES.,FXD,CMPSN:910 OHM,5%,0.25W	01121	CB9115
R127	315-0220-00			RES.,FXD,CMPSN:22 OHM,5%,0.25W	01121	CB2205
R128	315-0152-00			RES.,FXD,CMPSN:1.5K OHM,5%,0.25W	01121	CB1525
R129	315-0220-00			RES.,FXD,CMPSN:22 OHM,5%,0.25W	01121	CB2205
R200	315-0680-00			RES.,FXD,CMPSN:68 OHM,5%,0.25W	01121	CB6805
R205	315-0102-00			RES.,FXD,CMPSN:1K OHM,5%,0.25W	01121	CB1025
R206	311-0310-00			RES.,VAR,NONWIR:5K OHM,20%,0.50W	01121	W-7350A
R210	315-0101-00			RES.,FXD,CMPSN:100 OHM,5%,0.25W	01121	CB1015
R211	311-1224-00			RES.,VAR,NONWIR:500 OHM,20%,0.50W	32997	3386F-T04-501
R212	315-0221-00			RES.,FXD,CMPSN:220 OHM,5%,0.25W	01121	CB2215
R213	315-0271-00			RES.,FXD,CMPSN:270 OHM,5%,0.25W	01121	CB2715
R220	323-0150-00			RES.,FXD,FILM:357 OHM,1%,0.50W	91637	MFF1226G357R0F
R221	315-0150-00			RES.,FXD,CMPSN:15 OHM,5%,0.25W	01121	CB1505
R222	315-0152-00			RES.,FXD,CMPSN:1.5K OHM,5%,0.25W	01121	CB1525
R223	323-0196-00			RES.,FXD,FILM:1.07K OHM,1%,0.50W	91637	CMF1418G10700F
R225	315-0101-00			RES.,FXD,CMPSN:100 OHM,5%,0.25W	01121	CB1015
R226	315-0911-00			RES.,FXD,CMPSN:910 OHM,5%,0.25W	01121	CB9115
R228	315-0152-00			RES.,FXD,CMPSN:1.5K OHM,5%,0.25W	01121	CB1525
R300	315-0510-00			RES.,FXD,CMPSN:51 OHM,5%,0.25W	01121	CB5105
R301	315-0510-00			RES.,FXD,CMPSN:51 OHM,5%,0.25W	01121	CB5105

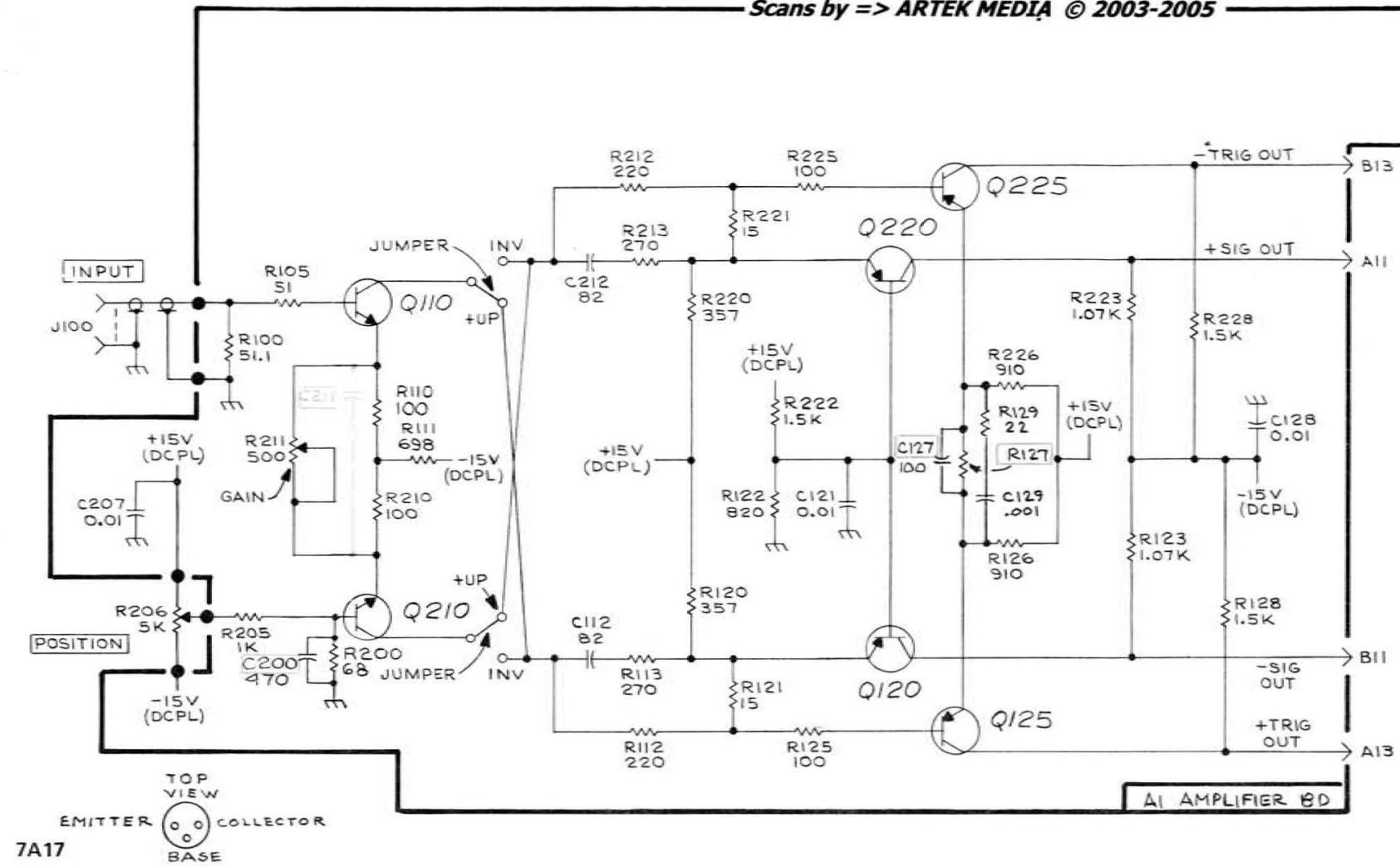

7A17

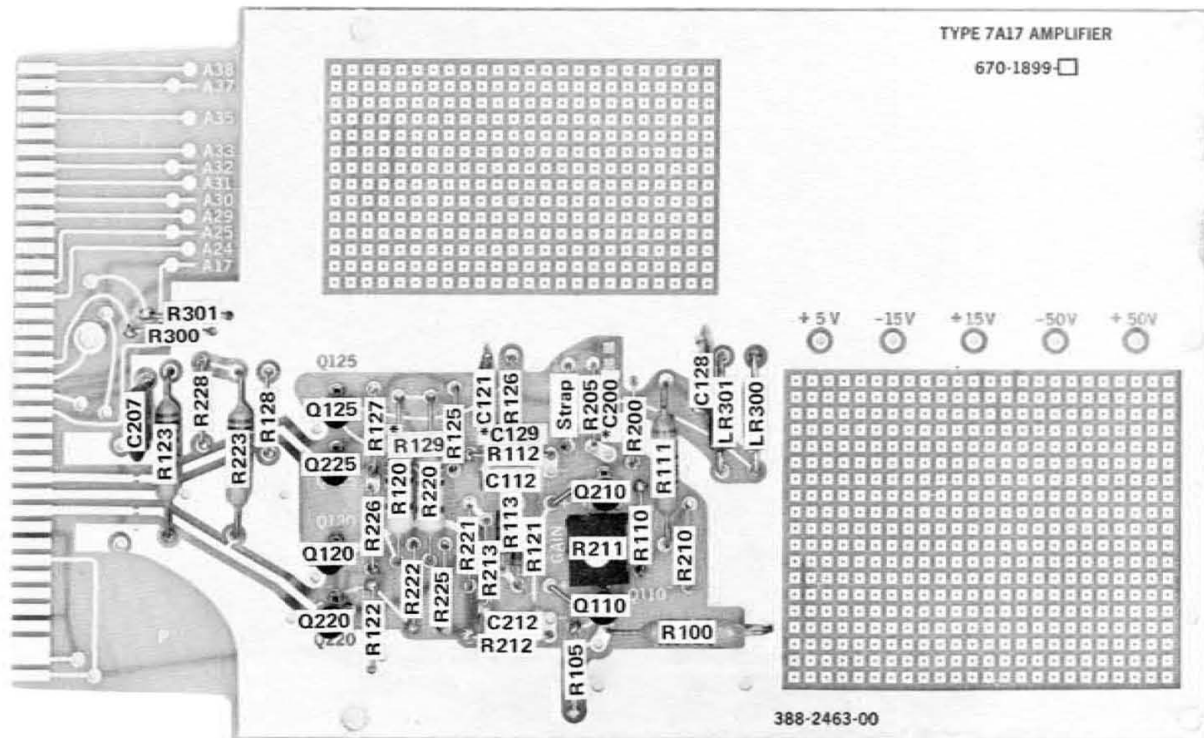

*C211 LOCATED ON BACK OF BOARD
7A17 Component Location

*See Parts List for serial number ranges.

REV APR 1984

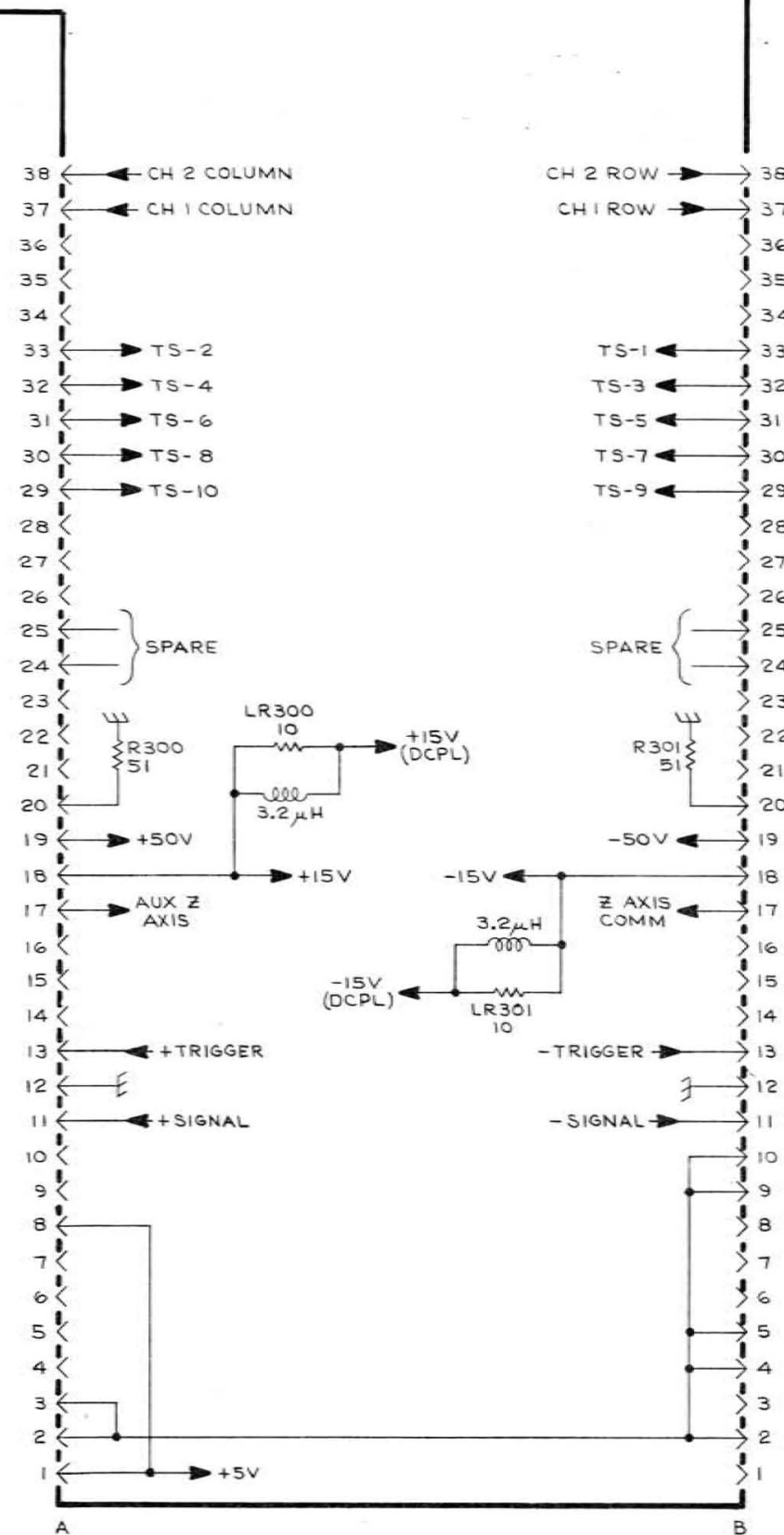

AMPLIFIER & CONNECTORS

GR5

REPLACEABLE MECHANICAL PARTS

PARTS ORDERING INFORMATION

Replacement parts are available from or through your local Tektronix, Inc. Field Office or representative.

Changes to Tektronix instruments are sometimes made to accommodate improved components as they become available, and to give you the benefit of the latest circuit improvements developed in our engineering department. It is therefore important, when ordering parts, to include the following information in your order: Part number, instrument type or number, serial number, and modification number if applicable.

If a part you have ordered has been replaced with a new or improved part, your local Tektronix, Inc. Field Office or representative will contact you concerning any change in part number.

Change information, if any, is located at the rear of this manual.

ITEM NAME

In the Parts List, an Item Name is separated from the description by a colon (:). Because of space limitations, an Item Name may sometimes appear as incomplete. For further Item Name identification, the U.S. Federal Cataloging Handbook H6-1 can be utilized where possible.

FIGURE AND INDEX NUMBERS

Items in this section are referenced by figure and index numbers to the illustrations.

INDENTATION SYSTEM

This mechanical parts list is indented to indicate item relationships. Following is an example of the indentation system used in the description column.

```

1 2 3 4 5           Name & Description
Assembly and/or Component
Attaching parts for Assembly and/or Component
    - - - * - - -
Detail Part of Assembly and/or Component
Attaching parts for Detail Part
    - - - * - - -
Parts of Detail Part
Attaching parts for Parts of Detail Part
    - - - * - - -
  
```

Attaching Parts always appear in the same indentation as the item it mounts, while the detail parts are indented to the right. Indented items are part of, and included with, the next higher indentation. The separation symbol - - - * - - - indicates the end of attaching parts.

Attaching parts must be purchased separately, unless otherwise specified.

ABBREVIATIONS

#	INCH NUMBER SIZE	ELECTRN	ELECTRON	IN	INCH	SE	SINGLE END
ACTR	ACTUATOR	ELEC	ELECTRICAL	INCAND	INCANDESCENT	SECT	SECTION
ADPTR	ADAPTER	ELCTLT	ELECTROLYTIC	INSUL	INSULATOR	SEMICOND	SEMICONDUCTOR
ALIGN	ALIGNMENT	ELEM	ELEMENT	INTL	INTERNAL	SHLD	SHIELD
AL	ALUMINUM	EPL	ELECTRICAL PARTS LIST	LPHLDR	LAMPHOLDER	SHLDR	SHOULDERED
ASSEM	ASSEMBLED	EQPT	EQUIPMENT	MACH	MACHINE	SKT	SOCKET
ASSY	ASSEMBLY	EXT	EXTERNAL	MECH	MECHANICAL	SL	SLIDE
ATTEN	ATTENUATOR	FIL	FILLISTER HEAD	MTG	MOUNTING	SLFLKG	SELF-LOCKING
AWG	AMERICAN WIRE GAGE	FLEX	FLEXIBLE	NIP	NIPPLE	SLVG	SLEEVING
BD	BOARD	FLH	FLAT HEAD	NON WIRE	NOT WIRE WOUND	SPR	SPRING
BRKT	BRACKET	FLTR	FILTER	OB	ORDER BY DESCRIPTION	SQ	SQUARE
BRS	BRASS	FR	FRAME or FRONT	OD	OUTSIDE DIAMETER	SST	STAINLESS STEEL
BRZ	BRONZE	FSTNR	FASTENER	OVH	OVAL HEAD	STL	STEEL
BSHG	BUSHING	FT	FOOT	PH BRZ	PHOSPHOR BRONZE	SW	SWITCH
CAB	CABINET	FXD	FIXED	PL	PLAIN or PLATE	T	TUBE
CAP	CAPACITOR	GSKT	GASKET	PLSTC	PLASTIC	TERM	TERMINAL
CER	CERAMIC	HDL	HANDLE	PN	PART NUMBER	THD	THREAD
CHAS	CHASSIS	HEX	HEXAGON	PNH	PAN HEAD	THK	THICK
CKT	CIRCUIT	HEX HD	HEXAGONAL HEAD	PWR	POWER	TNSN	TENSION
COMP	COMPOSITION	HEX SOC	HEXAGONAL SOCKET	RCPT	RECEPTACLE	TPG	TAPPING
CONN	CONNECTOR	HLCPS	HELICAL COMPRESSION	RES	RESISTOR	TRH	TRUSS HEAD
COV	COVER	HLEXT	HELICAL EXTENSION	RGD	RIGID	V	VOLTAGE
CPLG	COUPLING	HV	HIGH VOLTAGE	RLF	RELIEF	VAR	VARIABLE
CRT	CATHODE RAY TUBE	IC	INTEGRATED CIRCUIT	RTNR	RETAINER	W/	WITH
DEG	DEGREE	ID	INSIDE DIAMETER	SCH	SOCKET HEAD	WSHR	WASHER
DWR	DRAWER	IDENT	IDENTIFICATION	SCOPE	OSCILLOSCOPE	XFMR	TRANSFORMER
		IMPLR	IMPELLER	SCR	SCREW	XSTR	TRANSISTOR

Replaceable Mechanical Parts—7A17

CROSS INDEX—MFR. CODE NUMBER TO MANUFACTURER

Mfr. Code	Manufacturer	Address	City, State, Zip
000CY	NORTHWEST FASTENER SALES, INC.	7923 SW CIRRUS DRIVE	BEAVERTON, OR 97005
000FW	WESTERN SINTERING CO INC.	2620 STEVENS DRIVE	RICHLAND, WA 99352
22526	BERG ELECTRONICS, INC.	YOUK EXPRESSWAY	NEW CUMBERLAND, PA 17070
22599	ESNA, DIV. OF AMERACE CORPORATION	16150 STAGG STREET	VAN NUYS, CA 91409
73743	FISCHER SPECIAL MFG. CO.	446 MORGAN ST.	CINCINNATI, OH 45206
77820	BENDIX CORP., THE, ELECTRICAL COMPONENTS DIVISION	SHERMAN AVE.	SIDNEY, NY 13838
78189	ILLINOIS TOOL WORKS, INC. SHAKEPROOF DIVISION	ST. CHARLES ROAD	ELGIN, IL 60120
80009	TEKTRONIX, INC.	P O BOX 500	BEAVERTON, OR 97077
83385	CENTRAL SCREW CO.	2530 CRESCENT DR.	BROADVIEW, IL 60153
87308	N. L. INDUSTRIES, INC., SOUTHERN SCREW DIV.	P. O. BOX 1360	STATESVILLE, NC 28677
92101	SCHULZE MFG, 50 INGOLD RD BURLINGAME, CA 94010		

Fig. & Index No.	Tektronix Part No.	Serial/Model No.		Qty	1 2 3 4 5	Name & Description	Mfr Code	Mfr Part Number
		Eff	Dscont					
-1	366-0494-00			1		KNOB:GRAY WITH SETSCREW	80009	366-0494-00
	213-0153-00			1		.SETSCREW:5-40 X 0.125,STL BK OXD,HEX	000CY	OBD
-2	-----			1		RESISTOR,VAR:(SEE R206 EPL) *****ATTACHING PARTS)*****		
-3	210-0583-00			2		NUT,PLAIN,HEX:0.25-32 X 0.312 INCH,BRS	73743	2X20317-402
-4	210-0046-00			1		WASHER,LOCK:0.261 ID,INTL,0.018 THK,BRS *****END ATTACHING PARTS)*****	78189	1214-05-00-0541C
-5	366-1058-36			1		KNOB:LATCH *****ATTACHING PARTS)*****	80009	366-1058-36
-6	214-1095-00			1		PIN,SPG,SPLIT:0.094 OD X 0.187 INCH LONG *****END ATTACHING PARTS)*****	22599	52-022-094-0187
-7	105-0076-04			1		RELEASE BAR,LCH:PLUG-IN UNIT	80009	105-0076-04
-8	214-1280-00			1		SPRING,HLCPS:0.14 OD X 1.126"L,0.16"DIA	80009	214-1280-00
-9	333-1537-00			1		PANEL,FRONT:	80009	333-1537-00
-10	386-1447-54			1		SUBPANEL,FRONT: *****ATTACHING PARTS)*****	80009	386-1447-54
-11	213-0192-00			4		SCR,TPG,THD FOR:6-32 X 0.50 INCH,PNH STL *****END ATTACHING PARTS)*****	87308	OBD
-12	131-0126-00			1		CONNECTOR,RCPT,,:BNC,FEMALE *****ATTACHING PARTS)*****	77820	9663-1 NT-34
-13	210-0241-00			1		TERMINAL,LUG:0.515 ID X 0.625 INCH OD SE *****END ATTACHING PARTS)*****	80009	210-0241-00
-14	386-1402-00			1		PANEL,REAR: *****ATTACHING PARTS)*****	80009	386-1402-00
-15	213-0192-00			4		SCR,TPG,THD FOR:6-32 X 0.50 INCH,PNH STL	87308	OBD
-16	361-0326-00			1		SPACER,SLEEVE:0.18 ID X 0.25 OD X 0.10"L *****END ATTACHING PARTS)*****	80009	361-0326-00
-17	426-0736-00			1		FR SECT,PLUG-IN:TOP	80009	426-0736-00
-18	214-1061-00			1		SPRING,GROUND:FLAT	80009	214-1061-00
-19	220-0547-01			4		NUT,BLOCK:0.38 X 0.26 X 0.282 (2)4-40 *****ATTACHING PARTS)*****	000FW	OBD
-20	211-0105-00			4		SCREW,MACHINE:4-40 X 0.188,100 DEG,FLH ST *****END ATTACHING PARTS)*****	83385	OBD
-21	426-0737-00			1		FR SECT,PLUG-IN:BOTTOM	80009	426-0737-00
-22	214-1054-00			1		SPRING,FLAT:0.825 X 0.322,SST	80009	214-1054-00
-23	105-0075-00			1		BOLT,LATCH:7A & 7B SER PL-IN	80009	105-0075-00
-24	348-0235-00			2		SHLD GSKT,ELEC:4.734 INCH LONG	92101	OBD
-25	337-1064-04	B010100	B041765	2		SHIELD,ELEC:SIDE PLUG-IN UNITS	80009	337-1064-00
	337-1064-12	B041766		2		SHIELD,ELEC:SIDE FOR PLUG-IN UNIT	80009	337-1064-12
-26	175-0826-00			AR		WIRE,ELECTRICAL:3 WIRE RIBBON	80009	175-0826-00
-27	-----			1		CKT BOARD ASSY:AMPLIFIER(SEE A1 EPL)		
-28	352-0228-00			1		.HOLDER,CABLE:FOR 0.125"DIA CABLE,PLASTI	80009	352-0228-00
-29	136-0252-07			18		.SOCKET,PIN CONN:W/O DIMPLE *****ATTACHING PARTS FOR A1)*****	22526	75060-012
-30	211-0008-00			4		SCREW,MACHINE:4-40 X 0.250,PNH,STL,POZ	83385	OBD

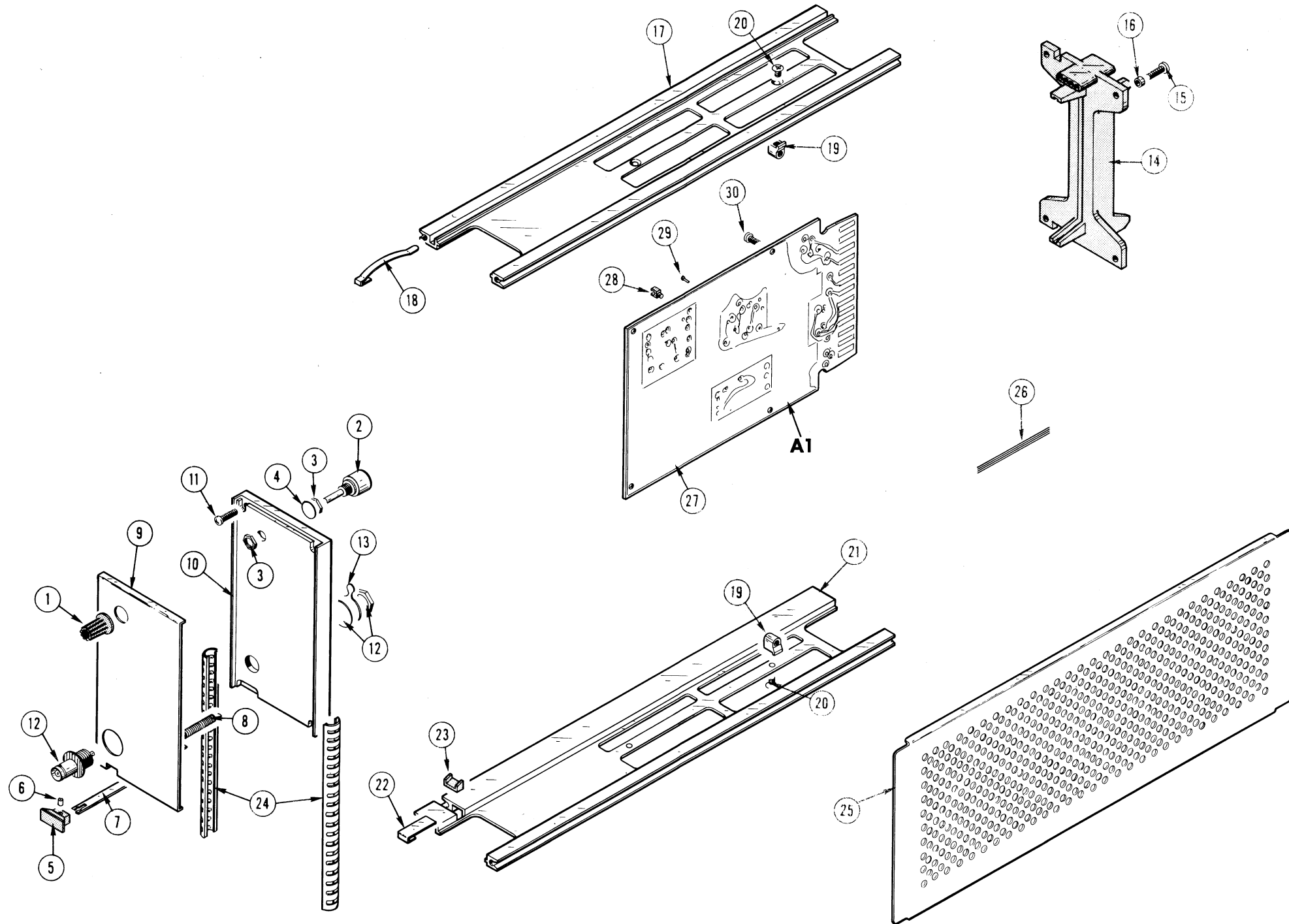

Fig. & Index No.	Tektronix Part No.	Serial/Model No.		Q t y						Description
		Eff	Disc		1	2	3	4	5	
	070-1263-00			1						MANUAL, instruction (not shown)

MANUAL CHANGE INFORMATION

At Tektronix, we continually strive to keep up with latest electronic developments by adding circuit and component improvements to our instruments as soon as they are developed and tested.

Sometimes, due to printing and shipping requirements, we can't get these changes immediately into printed manuals. Hence, your manual may contain new change information on following pages.

A single change may affect several sections. Since the change information sheets are carried in the manual until all changes are permanently entered, some duplication may occur. If no such change pages appear following this page, your manual is correct as printed.

DESCRIPTION

EFF SN B041562

REPLACEABLE ELECTRICAL PARTS AND SCHEMATIC CHANGES

CHANGE TO:

A1	670-1899-01	CKT BOARD ASSY:AMPLIFIER
Q110	151-0441-00	TRANSISTOR:SILICON,NPN
Q210	151-0441-00	TRANSISTOR:SILICON,NPN
R127	315-0270-00	RES.,FXD,CMPSN:27 OHM,5%,0.25W
ADD:		
C127	281-0523-00	CAP.,FXD,CER DI:100PF,20%,350V

DIAGRAM AMPLIFIER & CONNECTORS - Partial

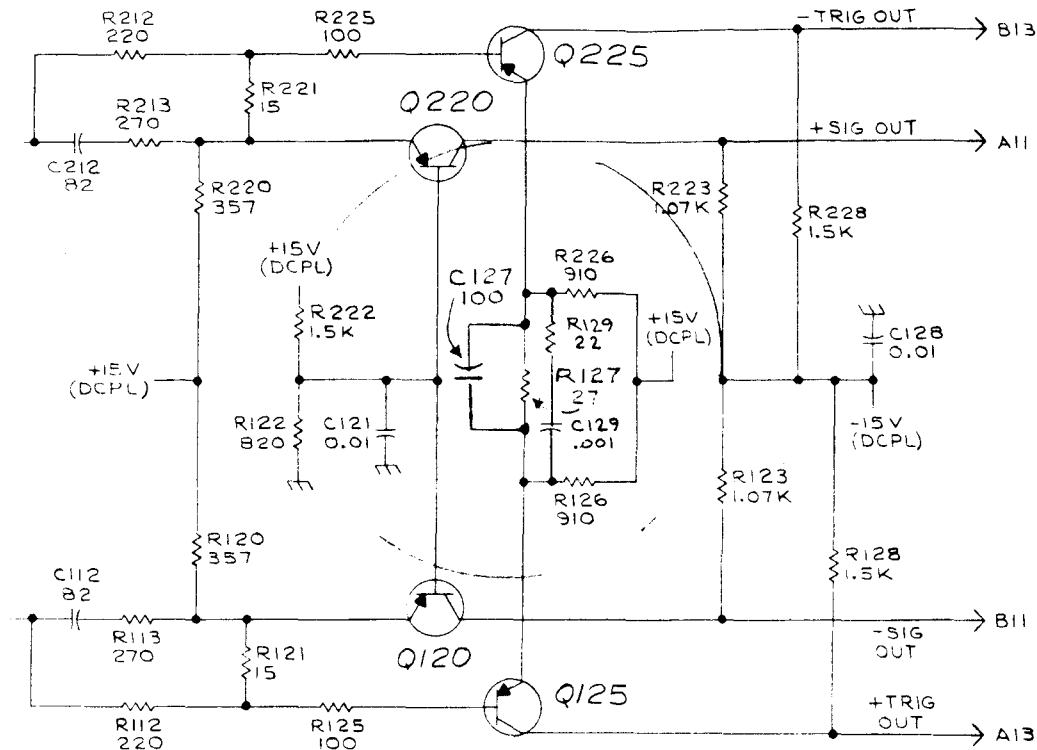

Scans By *Artek Media*

Artek Media
1042 Plummer Cir. SW
Rochester, MN 55902

www.artekmedia.com

"High resolution scans of obsolete technical manuals"

If your looking for a quality scanned technical manual in PDF format please visit our WEB site at www.artekmedia.com or drop us an email at manuals@artekmedia.com and we will be happy to email you a current list of the manuals we have available.

If you don't see the manual you need on the list drop us a line anyway we may still be able to point you to other sources. If you have an existing manual you would like scanned please write for details, This can often be done very reasonably in consideration for adding your manual to our library.

Typically the scans in our manuals are done as follows;

- 1) Typed text pages are typically scanned in black and white at 300 dpi.
- 2) Photo pages are typically scanned in gray scale mode at 600 dpi
- 3) Schematic diagram pages are typically scanned in black and white at 600 dpi unless the original manual had colored high lighting (as is the case for some 70's vintage Tektronix manuals).

If you purchased this manual from us (typically through our Ebay name of ArtekMedia) thank you very much. If you received this from a well-meaning "friend" for free we would appreciate your treating this much like you would "share ware". By that we mean a donation of at least \$5-10 per manual is appreciated in recognition of the time (a manual can take as much as 40 hours to reproduce, book, link etc.), energy and quality of effort that went into preserving this manual. Donations via PayPal go to: manuals@artekmedia.com or can be mailed to us the address above.

Thanks



Dave & Lynn Henderson
Artek Media