

TEKTRONIX®

7A21N

DIRECT ACCESS

INSTRUCTION MANUAL

Tektronix, Inc.
P.O. Box 500
Beaverton, Oregon 97005

Serial Number _____

070-1367-00

Scans by ArtekMedia © 2007

Scans by Outsource-Options =>

Scans By *Artek Media*

Artek Media
1042 Plummer Cir. SW
Rochester, MN 55902

www.artekmedia.com

"High resolution scans of obsolete technical manuals"

If you're looking for a quality scanned technical manual in PDF format please visit our WEB site at www.artekmedia.com or drop us an email at manuals@artekmedia.com and we will be happy to email you a current list of the manuals we have available.

If you don't see the manual you need on the list drop us a line anyway we may still be able to point you to other sources. If you have an existing manual you would like scanned please write for details, This can often be done very reasonably in consideration for adding your manual to our library.

Typically the scans in our manuals are done as follows;

- 1) Typed text pages are typically scanned in black and white at 300 dpi.
- 2) Photo pages are typically scanned in gray scale mode at 600 dpi
- 3) Schematic diagram pages are typically scanned in black and white at 600 dpi unless the original manual had colored high lighting (as is the case for some 70's vintage Tektronix manuals).

If you purchased this manual from us (typically through our Ebay name of ArtekMedia) thank you very much. If you received this from a well-meaning "friend" for free we would appreciate your treating this much like you would "share ware". By that we mean a donation of at least \$5-10 per manual is appreciated in recognition of the time (a manual can take as much as 40 hours to reproduce, book, link etc.), energy and quality of effort that went into preserving this manual. Donations via PayPal go to: manuals@artekmedia.com or can be mailed to us the address above.

Thanks



Dave & Lynn Henderson
Artek Media

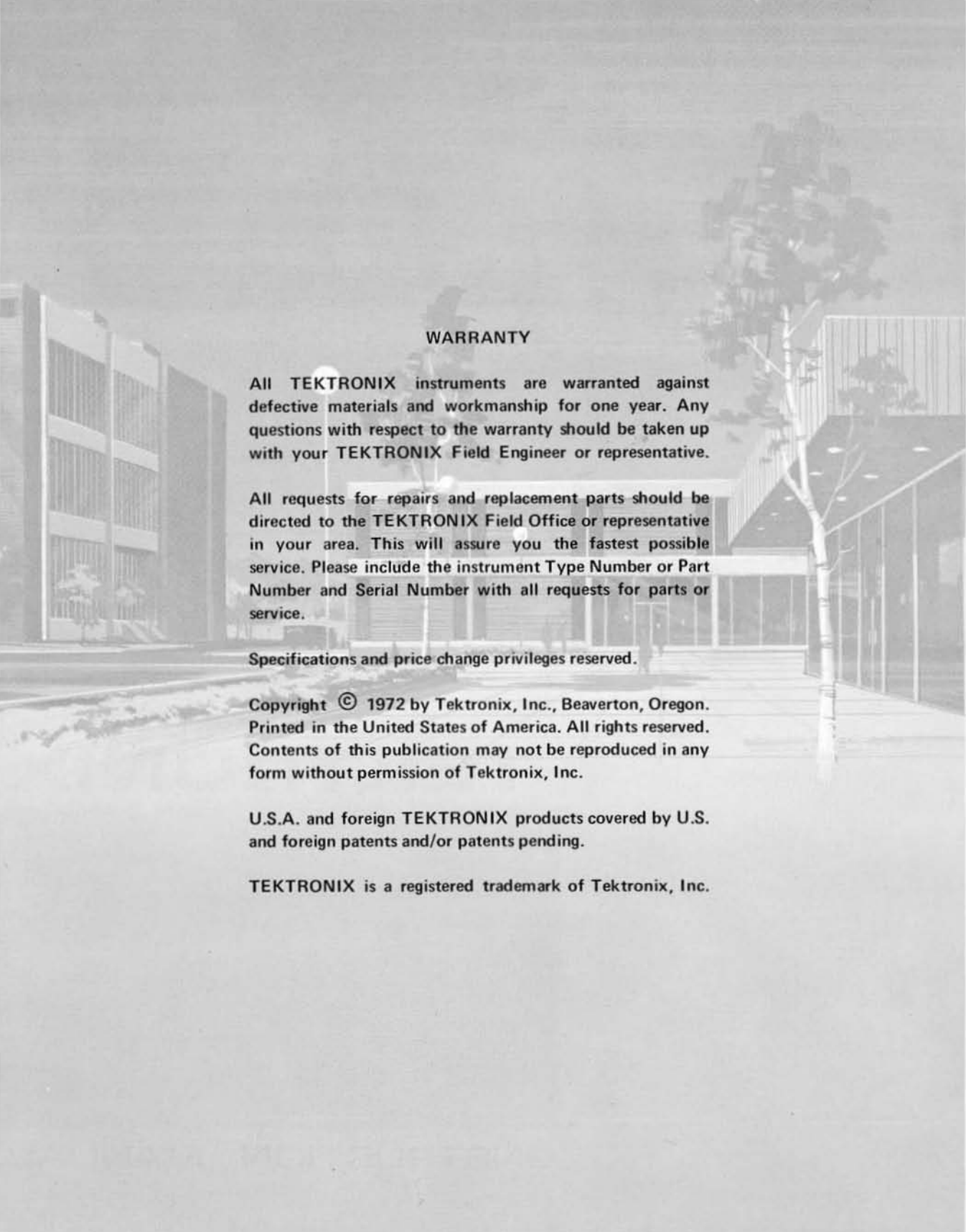

WARRANTY

All TEKTRONIX instruments are warranted against defective materials and workmanship for one year. Any questions with respect to the warranty should be taken up with your TEKTRONIX Field Engineer or representative.

All requests for repairs and replacement parts should be directed to the TEKTRONIX Field Office or representative in your area. This will assure you the fastest possible service. Please include the instrument Type Number or Part Number and Serial Number with all requests for parts or service.

Specifications and price change privileges reserved.

Copyright © 1972 by Tektronix, Inc., Beaverton, Oregon. Printed in the United States of America. All rights reserved. Contents of this publication may not be reproduced in any form without permission of Tektronix, Inc.

U.S.A. and foreign TEKTRONIX products covered by U.S. and foreign patents and/or patents pending.

TEKTRONIX is a registered trademark of Tektronix, Inc.

TABLE OF CONTENTS

	Page
Operating Instructions	1
Installation	1
General Operating Instructions	4
Specifications	5
Circuit Description	5
Maintenance	6
Calibration	7
Performance Check	7
Electrical Parts List	11
7A21N Diagram	1
Mechanical Parts List	13

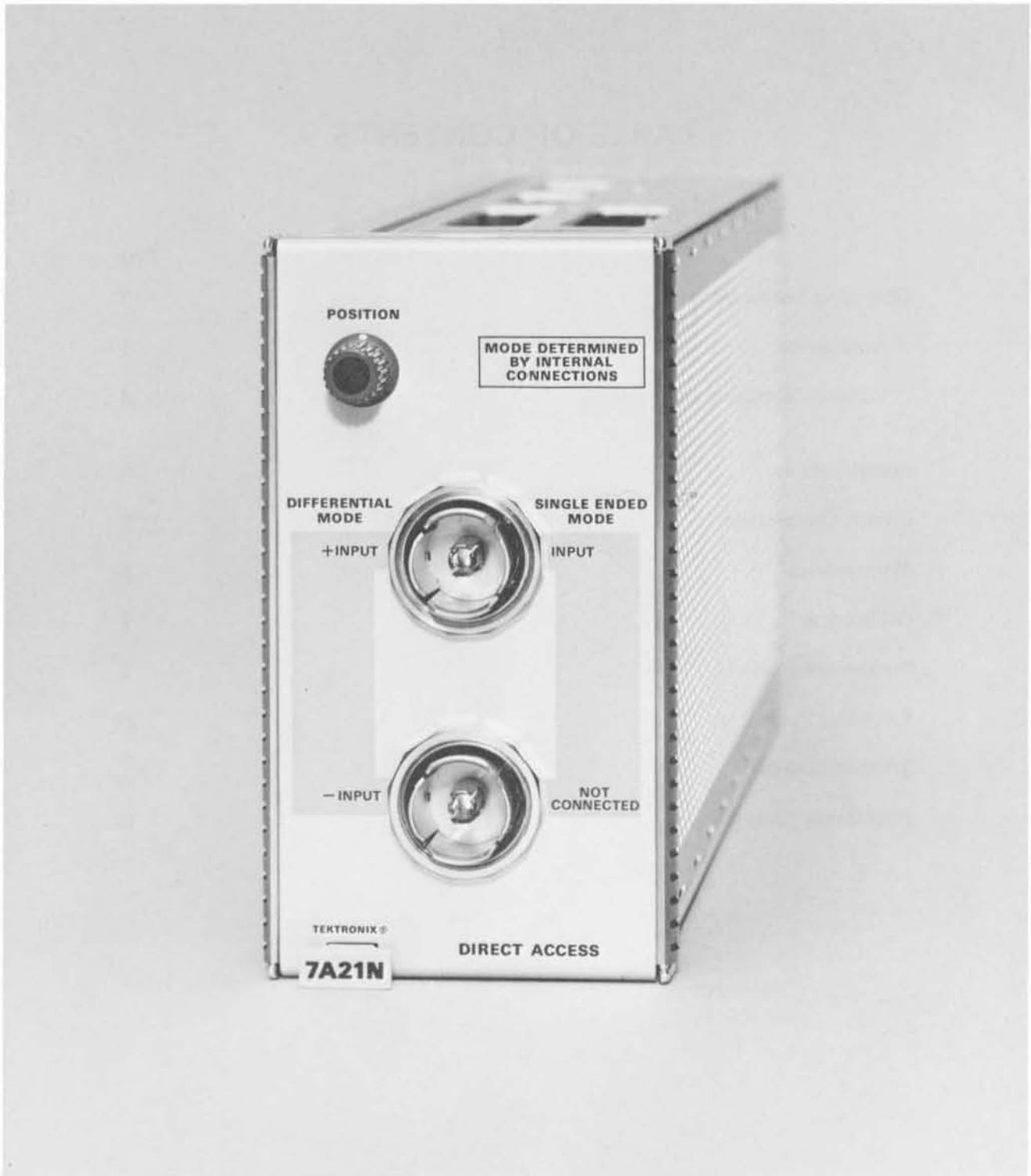

7A21N Features

The 7A21N Direct Access plug-in is designed for use with TEKTRONIX 7900-Series oscilloscopes. This unit provides AC coupling of high-frequency or fast-risetime signals directly to the CRT vertical deflection plates. Two front-panel input connectors permit either single ended or differential operation (internally selected). Trace positioning is accomplished with a front-panel control.

OPERATING INSTRUCTIONS

General

To effectively use the 7A21N, the operation and capabilities of the instrument must be known. This section gives installation procedures, describes front panel controls, and gives general information on operation and signal connections.

INSTALLATION

The 7A21N is designed to operate in the Left Vertical plug-in compartment of TEKTRONIX 7900-Series oscilloscope mainframes. When shipped from the factory, this instrument has been calibrated to meet the tolerances listed in the Performance Requirement column in the Specification section.

Installation includes replacing the mainframe Vertical Amplifier board with the 7A21N CRT Input Network and

the 7A21N CRT Termination assembly. The CRT Input Network and 7A21N CRT Termination assembly are provided as standard accessories and are stored on the left side of the 7A21N, see Fig. 1. Cable and wire assemblies are provided to connect the signal and the position control voltages to the CRT deflection plates. The parts of the mainframe affected by this installation and their relative locations are shown in the before and after illustrations in Fig. 2.

Installation Procedure

Preliminary

1. Disconnect the mainframe from the power source.
2. Remove all plug-in units from the vertical compartments.
3. Remove the left side panel from the mainframe.

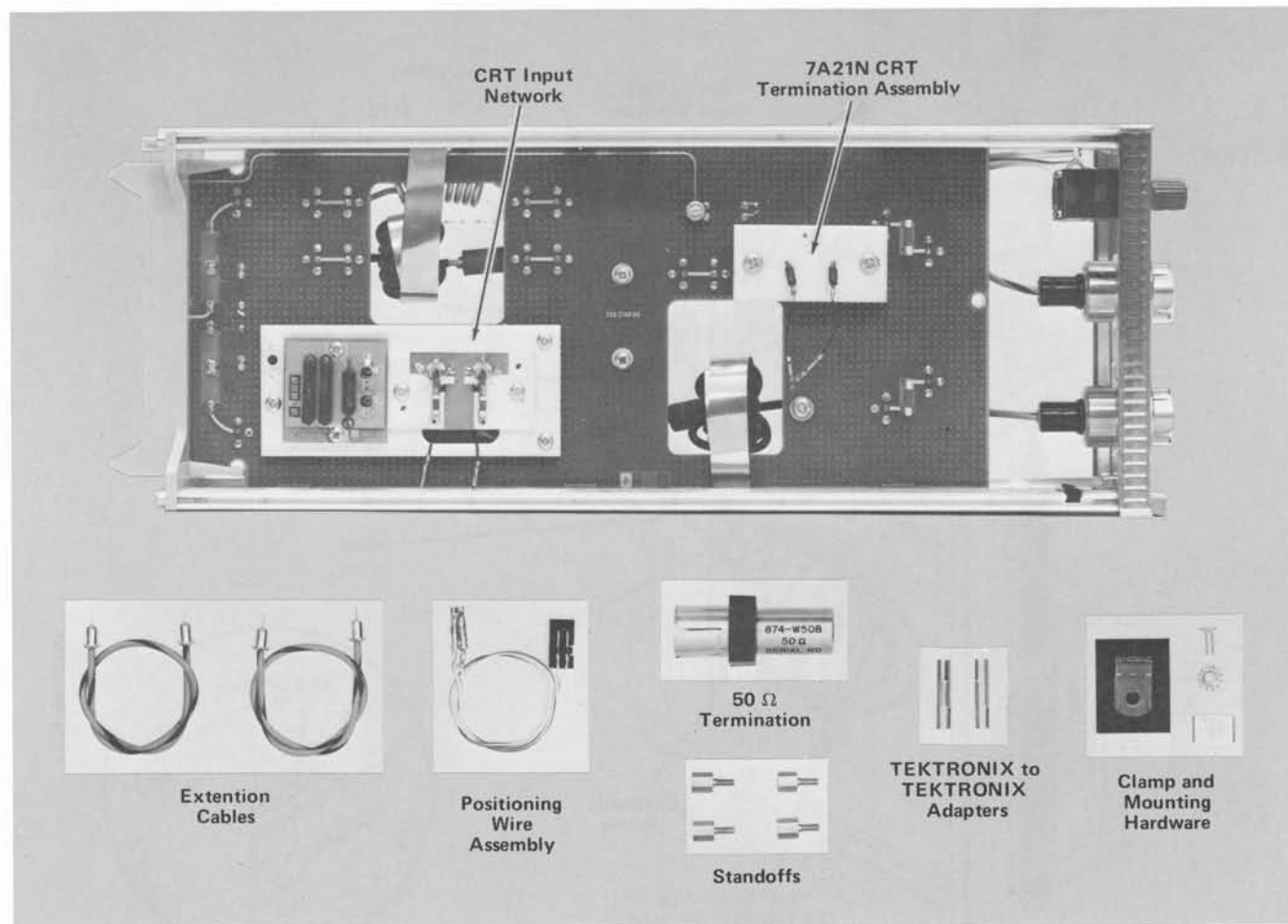
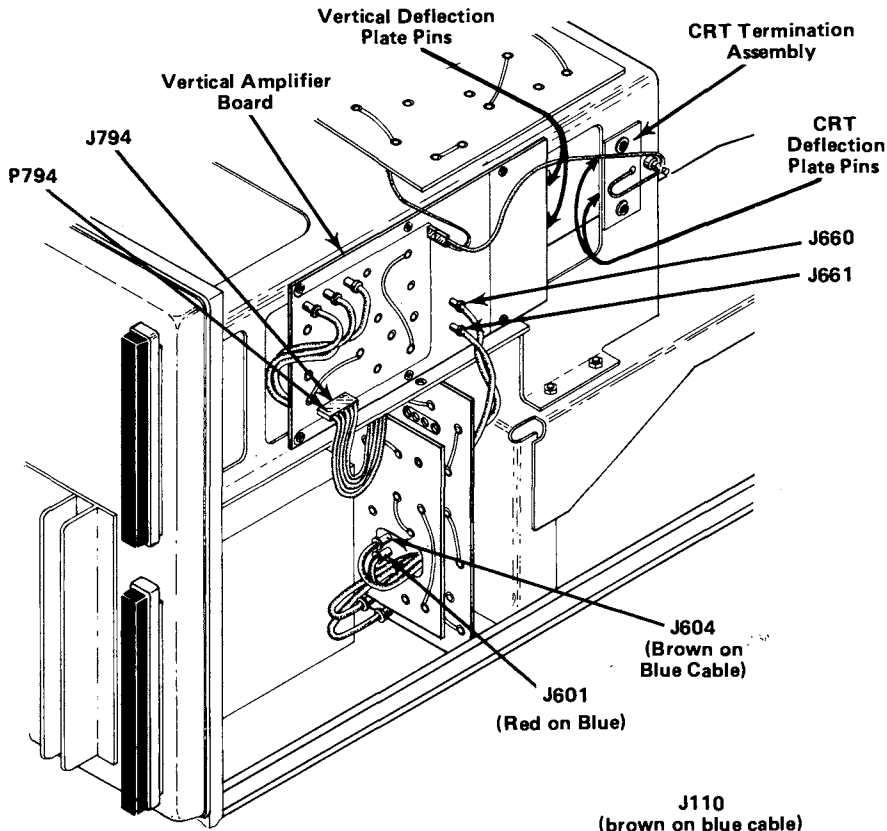

Fig. 1. Standard accessories supplied with 7A21N.

Before



After

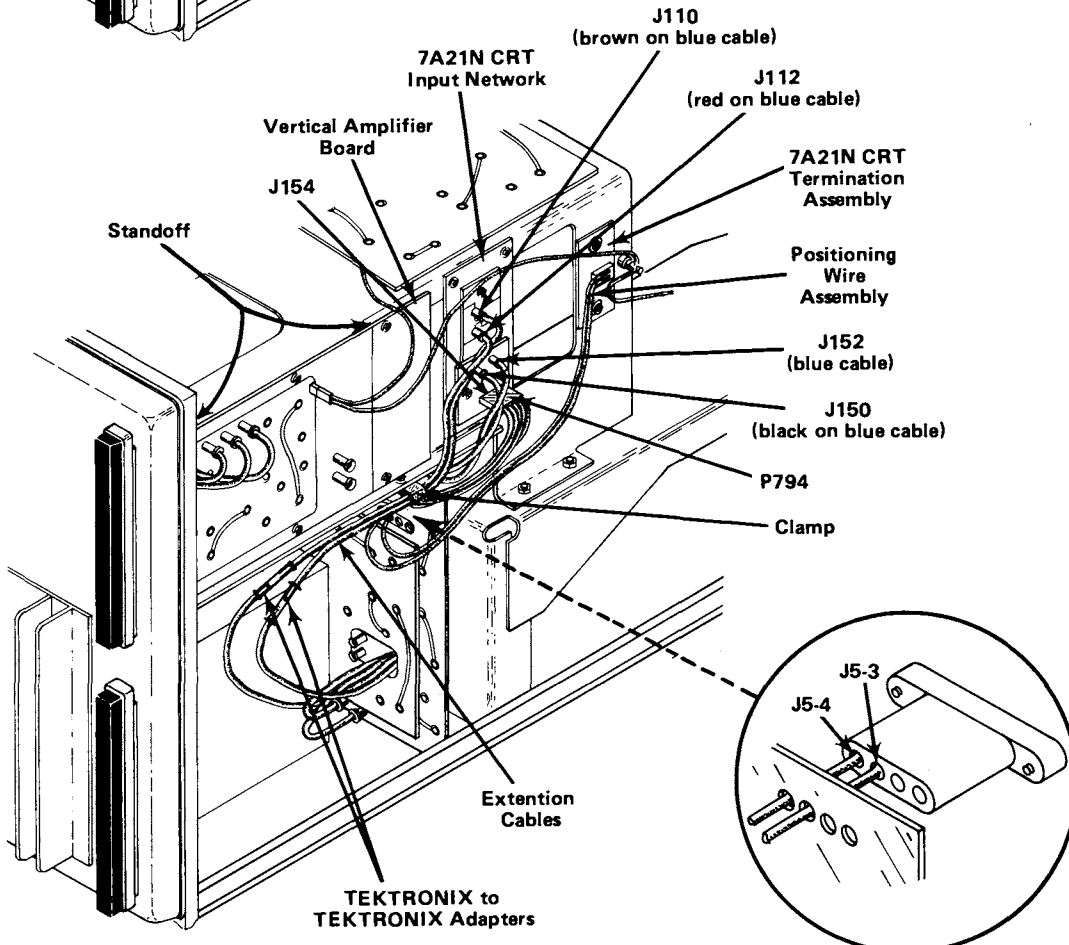

Fig. 2. Shows board positions and cable connections before and after installation of 7A21N.

Fig. 3. Installation of positioning wire assembly.

Move Vertical Amplifier Board

4. Remove the nine screws securing the Vertical Amplifier board to the mainframe. Disconnect the vertical deflection plate leads from the CRT. Disconnect all cables and connectors from the Vertical Amplifier board except the cables connected to J660 and J661.

5. Install the four standoffs (shown in Fig. 1) in the holes on the chassis. These standoffs are used to mount the Vertical Amplifier board to the rear of the board's original position. The three cables to be connected to the top left corner of the Vertical Amplifier board will have to be re-routed to accommodate the new board location. Secure the board to the standoffs using four of the nine screws removed in step 4. Reconnect the 3 cables connected to the top left of the board and the 2 pin connector.

NOTE

If the red on white wire of the 2-pin connector is too short to allow the connector to seat, replace it with one supplied with the 7A21N.

Install CRT Input Network

6. Remove the CRT Input Network assembly from the storage space in the 7A21N (see Fig. 1). Mount the CRT Input Network assembly to the chassis, using four of the nine screws removed in step 4. Refer to Fig. 2 for exact board locations.

7. Connect the leads located on the underside of the CRT Input Network to the vertical deflection plate pins. After these leads are connected, lightly pull on each lead to be sure it will remain connected. These leads should be dressed close to each other to obtain optimum high frequency characteristics.



Use care when handling the CRT pin connectors. The CRT pins may break if the pins are bent.

Replace CRT Termination Assembly

8. Remove the two screws securing the CRT Termination assembly to the oscilloscope chassis, refer to Fig. 2 for location. Disconnect the pin connectors from the CRT Termination assembly and the CRT. Remove the CRT Termination assembly.

9. Remove the 7A21N CRT Termination assembly from the storage space in the 7A21N, see Fig. 1. Mount the

7A21N CRT Termination assembly to the oscilloscope chassis, using the hardware removed in step 8.

10. Connect the leads located on the underside of the 7A21N CRT Termination assembly to the CRT deflection plates. Lightly pull on each lead to be sure it will remain connected.

Connect Cables and Connectors

11. Move the cable connected to J660 (blue) to J152 on the CRT Input Network, see Fig. 2.

12. Move the cable connected to J661 (black on blue) to J150 on the CRT Input Network, see Fig. 2.

13. Move the multi-pin connector, P794, (previously connected to J794 on the Vertical Amplifier board) to J154 on the CRT Input Network. The connector index (end with brown lead) should be toward the rear of the oscilloscope.

14. Remove the cable connected to J604 (brown on blue) and connect it to J110 on the CRT Input Network by using the TEKTRONIX to TEKTRONIX adapter¹ and the brown on blue extension cable. See Fig. 2.

15. Remove the cable connected to J601 (red on blue) and connect it to J112 on the CRT Input Network by using the TEKTRONIX to TEKTRONIX adapter¹ and the red on blue extension cable. See Fig. 2.

16. Clamp the two cables installed in steps 14 and 15 to the chassis, using the clamp and hardware supplied with the 7A21N. See Fig. 2.

17. Insert the connectors of the Positioning Wire assembly into sockets J5-3 and J5-4, located on the oscilloscope interface connector. Refer to Fig. 2 and close-up in Fig. 3. Push the connectors into the sockets until they snap into place. It may be necessary to use a pair of long-nose pliers or tweezers to push the sockets until they extend beyond the plastic housing. These connectors are now permanently installed and cannot be removed.

18. Connect the multi-pin connector end of the Positioning Wire assembly to J120 of the CRT Termination

¹In some earlier oscilloscope models, SEAELECTRO connectors are used. In these cases, the 7A21N can be equipped with special SEAELECTRO cable assemblies. Consult your TEKTRONIX Field Engineer or Representative for details.

7A21N

assembly. The connector index (end with brown on white lead) should be toward the bottom of the oscilloscope.

19. Fully insert the 7A21N into the oscilloscope Left Vertical compartment. This completes the installation procedures for the 7A21N.

Removal

To use other plug-in units in the Vertical compartments of the mainframe, it is necessary to remove the parts added for direct-access operation with the exception of the Positioning Wire assembly. The connector ends of this assembly are permanently installed and should not be removed. The multi-pin connector end of this assembly,

however, should be disconnected and placed where it will not interfere with operation of this mainframe.

GENERAL OPERATING INSTRUCTIONS

Modes of Operation

The 7A21N can be connected (internally) for single-ended operation of differential operation. The illustrations shown in Fig. 4 show the internal cable connections used for the single ended and differential modes of operation.

When used in the differential mode and if only one input is used, the other input should be terminated into 50Ω . It is always good practice to terminate the unused input. Use the 50Ω Terminator supplied with the 7A21N.

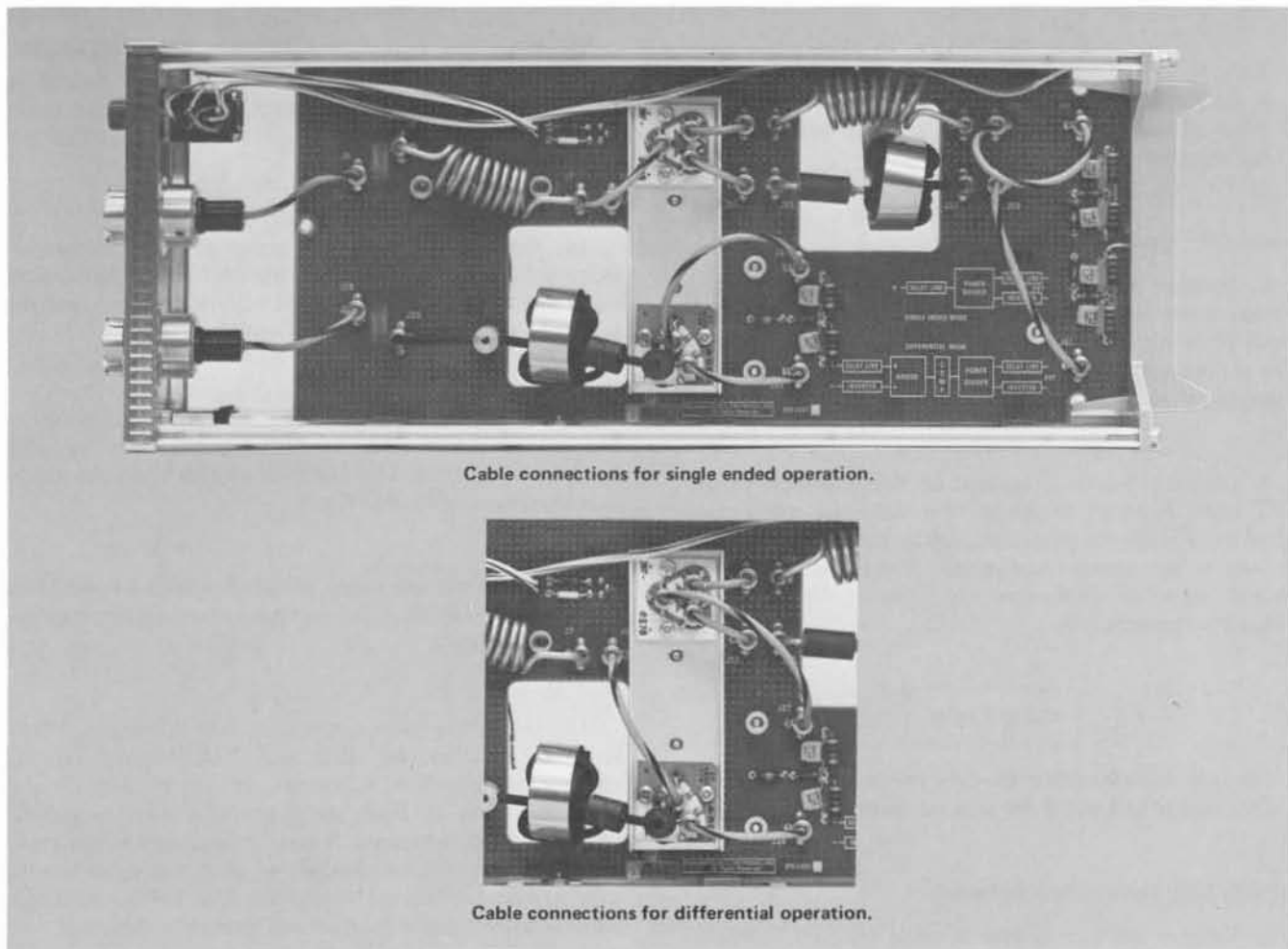

Fig. 4. Cable connections for single-ended and differential operation.

SPECIFICATION

The following electrical characteristics are valid for instruments calibrated at an ambient temperature between +20°C and +30°C after a 20 minute warmup period.

TABLE 1-1
ELECTRICAL CHARACTERISTICS

Characteristic	Performance Requirement	Supplemental Information
Deflection Factor		
Single Ended Mode	Less than four volts/division	
Differential Mode	Less than ten volts/division	
Bandwidth	20 kilohertz to one gigahertz	
Maximum Input Power (Each Input)	Six watts average; 200 volts DC	
Input Impedance (Each Input)	50 ohms, AC coupled	
Reflection Coefficient	0.1 peak-to-peak	Using a reflectometer with a system risetime of 75 ps.

CIRCUIT DESCRIPTION

The 7A21N circuitry is explained first as internally connected for the differential mode of operation, then as internally connected for the single-ended mode of operation. It should be noted that the entire signal line is designed to maintain a constant impedance of 50 Ω .

The signal connected to the -INPUT is AC coupled through C18 and inverted in L21. The signal is inverted to provide proper phasing with the +INPUT signal. After inversion, the signal is algebraically added to the +INPUT signal in the 50 Ω Bridge, U12. The characteristics of this bridge are such that each input is terminated into 50 Ω and the output of the bridge has a source impedance of 50 Ω .

The signal connected to the +INPUT is AC coupled through C5, then connected to U12 through the delay line, L6. The delay time of L6 is calculated so that the transit time from the +INPUT connector to U12 is the same as the transit time from the -INPUT connector to U12.

The output of the 50 Ω Bridge assembly, U12, is connected to the compensating network composed of R24, C24, R25, C25, R26, and L26. This network compensates

for the skin effect losses and line losses in U12 and the cables.

Power divider U30 splits the signal into two directions. The characteristics of the Power Divider are such that, when properly terminated, the impedance looking into any leg is 50 Ω .

The output of U30 at J31 is inverted at L56. Components R61, C61, R62, C62, R63, and L63 compensate for skin effect losses and line losses of the cables, the Inverter, and the Power Divider. The signal is then capacitively coupled to the CRT deflection plate. The output of U30 at J30 is connected to the delay line L36. Delay time for L36 is calculated so that the transit times of the inverted and non-inverted signals are equal. R41, C41, R42, C42, R43, and L43 compensate for the skin effect losses and line losses of the cables, delay line and Power Divider. The non-inverted signal is connected to the CRT Input Network where it is capacitively coupled to the CRT vertical deflection plate. The 69 Ω resistors on the CRT Input Network parallel the 182.5 Ω impedance of the deflection plates to form 50 Ω termination for the inverted and non-inverted signals.

7A21N

Single ended circuitry is similar to differential circuitry except that the $-INPUT$ is not used and the signal at the $+INPUT$ bypasses $50\ \Omega$ Bridge U12 and the compensation network R24, C24, R25, C25, R26, and L26.

The vertical deflection plates are terminated into their characteristic impedance by the CRT Termination Assembly, U120. Positioning voltage is supplied from R96.

R98 sets the nominal position voltage. This control also has an effect on the CRT trace focus.

The Load Board (located on U110) provides a storage space for the power line that was removed from the Oscilloscope Vertical Amplifier board. The $+50\text{ V}$ and -15 V supplies in the power line are loaded so that the supplies stay in regulation during direct access operation. Proper bias is supplied from the Load Board to protect the oscilloscope Channel Switch.

MAINTENANCE

General

This portion of the manual contains information concerning preventive maintenance, corrective maintenance and troubleshooting the 7A21N.

Cleaning

To improve reliability and to avoid possible electrical problems, it is recommended that the 7A21N be cleaned at periodic intervals.

Loose dust may be removed with a soft cloth or a dry brush. Hardened dirt can be removed with a cotton-tipped swab or cloth, dampened with a mild detergent and water solution, then carefully rinsed and dried.

NOTE

Calibration of the 7A21N can be effected if the physical position of the components are moved.

Troubleshooting

If trouble is suspected, before moving or replacing any components, check that all cables and interconnections are properly made. Refer to the Operating Instructions portion of this manual for complete information. If trouble is still evident and if calibration does not correct the problem, then a component malfunction is the likely cause.

Since the 7A21N contains no active components, all that is usually required to locate the defective part is an ohmmeter. A reflectometer (such as the TEKTRONIX 7L12 or 1501) can be used to pinpoint the problem area by checking for discontinuities in the $50\ \Omega$ signal path.

Before replacing any component first note the physical position of the component. Install the replacement part in the same position.

Corrective Maintenance

Standard Replacement Parts. All electrical and mechanical replacement parts for the 7A21N can be obtained through your local field office or representative. However, many of the electronic parts can be obtained locally in less time than is required to order them from Tektronix, Inc. Before purchasing or ordering replacement parts, check the parts list for value, rating, tolerance, and description.

Special Parts. In addition to the standard electronic components, some special parts are used in the 7A21N. These parts are manufactured or selected by Tektronix, Inc. in accordance with our specifications. These special parts are indicated in the parts list by an asterisk preceding the part number. Order all special parts directly from your local TEKTRONIX Field Office or representative.

Ordering Parts. When ordering replacement parts from Tektronix, Inc., include the instrument type, instrument serial number, a description of the part (if electrical include circuit number), and the TEKTRONIX part number.

Soldering Techniques. Care should be taken when soldering to prevent damage due to excess heat. A small wattage soldering iron (15 to 50 watts) should be used. Apply heat directly to the junction to be soldered. Use only enough heat to form a good bond. Heat sink components when necessary.

CALIBRATION

Adjustment Procedure

Two methods of setting the 7A21N Vertical Voltage adjustment follow. If a focused trace was obtained prior to the installation procedure, use Method A. An alternative adjustment procedure is given as Method B.

Method A:

1. Position the trace to the center of the CRT graticule area with the 7A21N POSITION control.
2. Adjust Vertical Voltage adjustment, R98 (located on left side of 7A21N) for a well-defined trace.

Method B:

1. Position the trace to the center of the CRT graticule area with the 7A21N POSITION control.
2. Measure and record the DC voltage between pin 10 of the cathode ray tube and ground. Use a VOM set to the 50 V range, or higher, for this purpose.

NOTE

Pin 10 of the CRT connects to the shield surrounding the Vertical Deflection plates. The easiest place to measure the voltage of this shield is on the multi-pin connector connecting pin 10 of the CRT to the Z Axis Amplifier board. Refer to the oscilloscope mainframe manual for the exact location.

3. Measure the DC voltage between each of the two Vertical deflection plates and ground. Average these two answers by the formula:

$$V_{\text{average}} = \frac{V_1 + V_2}{2}$$

4. Adjust the Vertical Voltage adjustment, R98 so that the voltage measured at pin 10 of the CRT (step 2) and the V_{average} (calculated from step 3) are within 0.5 volt.

This completes the adjustment for the 7A21N.

PERFORMANCE CHECK

General

The performance of this instrument can be checked without making any internal adjustments by using the following procedure. This procedure checks the instrument against tolerances listed in the Specification section of this manual. If the instrument does not meet any or all of these specifications it is due to a malfunction. Refer to the Troubleshooting portion of this manual for possible causes and corrective techniques.

Test Equipment Required

General. The following test equipment and accessories, or its equivalent, is required for a complete check of the 7A21N. Specifications given for the test equipment are the minimum necessary for an accurate check. Therefore, the specifications of any test equipment used must meet or exceed the listed specifications. All test equipment is assumed to be correctly calibrated and operating within the listed specifications. Detailed operating instructions for the test equipment are not given in this procedure. Refer to the instruction manual for the test equipment if more information is needed.

Special Calibration Fixtures. Special TEKTRONIX test fixtures are used in this procedure only where they facilitate the Performance Check. These special test fixtures are available from Tektronix, Inc. Order by part number through your local TEKTRONIX Field Office or representative.

Test Equipment Alternatives. All of the listed test equipment is required to completely check this instrument. The Performance Check procedure is based on the first item of equipment given as an example of applicable equipment. When other equipment is substituted, control settings or test setup may need to be altered slightly to meet the requirements of the substitute equipment. If the exact item of test equipment given as an example in the Test Equipment list is not available, first check the Specifications column carefully to see if any other equipment is available which might suffice. Then check the Usage column to see what this item of test equipment is used for. If used for a check which is of little or no importance to your measurement requirements, the item and corresponding step(s) can be deleted.

TEST EQUIPMENT

Description	Minimum Specifications	Usage	Examples of Applicable Test Equipment
1. Calibration Oscilloscope	TEKTRONIX 7900-Series 7A21N system bandwidth to 1 GHz.	Used throughout procedure to provide display.	a. TEKTRONIX 7904 oscilloscope with 7A21N installed.
2. Time Base Plug-in Unit	TEKTRONIX 7B-Series time base unit. 0.5 ns sweep rate required.	Used throughout procedure to provide sweep.	a. TEKTRONIX 7B92 Time Base Unit.
3. Test Oscilloscope	Complete with time base unit and vertical unit. Must have vertical deflection factor of 5 V/div.	Used for deflection factor check.	a. TEKTRONIX 7603 Oscilloscope with TEKTRONIX 7A16A Vertical Unit and 7B50 Time Base Unit or equivalent.
4. Time Domain Reflectometer	System risetime, 75 ps; pulse amplitude, 200 mV; input, single ended; sensitivity, to 100 mV.	Used to check input reflections and transit time.	a. TEKTRONIX 7S12 TDR/SAMPLER plug-in unit with S-52 Pulse Generator head and S-2 Sampling head. (This system to be used with the Test oscilloscope.)
5. Square-wave Generator	Frequency, to 75 kHz; output amplitude, 10 volts P-P into 50 Ω .	Used to check Deflection Factor.	a. TEKTRONIX 106 Square Wave Generator.
6. Pulse Generator	Pulse risetime, 250 ps or less; pulse amplitude to 50 volts or greater.	Used to check risetime and aberrations.	a. TEKTRONIX 109 Pulse Generator.
7. Delay Line and Trigger Pickoff	Delay time, approximately 75 ns; risetime, 175 ps or less.	Used to check risetime and aberrations.	a. TEKTRONIX 7M11 Delay Line plug-in unit.

Cables and Accessories

8. TEKTRONIX to GR adapter	TEKTRONIX female to GR adapter.	Used for transit time check.	a. TEKTRONIX Part Number 017-0093-00.
9. 20 ns Cable	Connectors, GR; impedance, 50 Ω ; time delay, 20 ns.	Used for risetime and aberration checks and other signal connections.	a. TEKTRONIX Part Number 017-0504-00.
10. GR Cable (2 each)	Connectors, GR; impedance, 50 Ω ; length, 20-inch.	Used throughout procedures for signal connections.	a. TEKTRONIX Part Number 017-0515-00.
11. BNC Cable	Connectors, BNC; impedance, 50 Ω ; length, 42-inch.	Used for external trigger in the risetime and aberration check.	a. TEKTRONIX Part Number 012-0057-01.
12. SMA Male to GR Adapter	SMA (3 mm) to GR adapter.	Used for connections to Time-Domain Reflectometer pulse generator.	a. TEKTRONIX Part Number 015-1007-00.

Preliminary Set Up

1. Connect the 7A21N internal connections for single-ended operation.

2. Install the 7A21N into the Calibration Oscilloscope and turn power on.

Check Reflection Coefficient

1. Connect the Time-Domain Reflectometer to the 7A21N +INPUT. Check that the reflections are 0.1 peak-to-peak or less (100 m μ peak-to-peak or less).

2. Change the 7A21N internal connections for differential operation.

3. Connect the Time-Domain Reflectometer to the 7A21N +INPUT. Check that the reflections are 0.1 peak-to-peak or less (100 m μ peak-to-peak or less).

4. Connect the Time-Domain Reflectometer to the 7A21N -INPUT. Check that the reflections are 0.1 peak-to-peak or less (100 m μ peak-to-peak).

Check +INPUT/-INPUT Transit Time

1. Remove the right side cover of the 7A21N. It is not necessary to plug the 7A21N into the Calibration Oscilloscope for this check.

2. Remove the cable connected to J29 (on U30). Connect the end of this cable to the Time-Domain Reflectometer sampling head by using the TEKTRONIX to GR adapter and GR Cable.

3. Connect the Time-Domain Reflectometer pulse generator to the 7A21N +INPUT. Set the Reflectometer Time/Div to 50 ps.

4. Use the Time-Domain Reflectometer controls to obtain a full graticule display of the rising portion of the pulse. Adjust the controls so that the pulse starts at the lower left side of the graticule and intersects the graticule center lines, see Fig. 5.

5. Without moving any controls, move the pulse generator to the -INPUT.

6. Vertically position the trace so that the pulse (now negative going) starts at the graticule upper left side. Check that the trace intersects the horizontal graticule centerline within ± 25 ps of the vertical line, see Fig. 6.

7. Disconnect Time-Domain Reflectometer. Reconnect the cable to J29.

Alternate Procedure

Some reflectometers do not have a separate pulse generator output and sampling input. If this is the case, disconnect the cable connected to J29 and measure that the reflected pulses at the +INPUT and -INPUT is within 50 ps of one another.

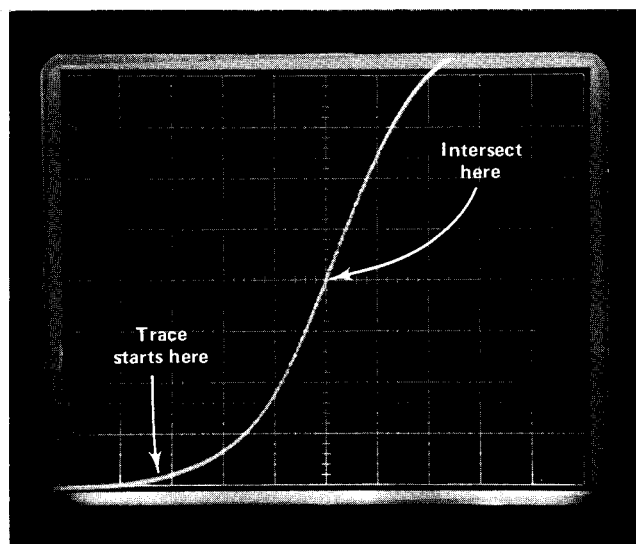

Fig. 5. +INPUT signal.

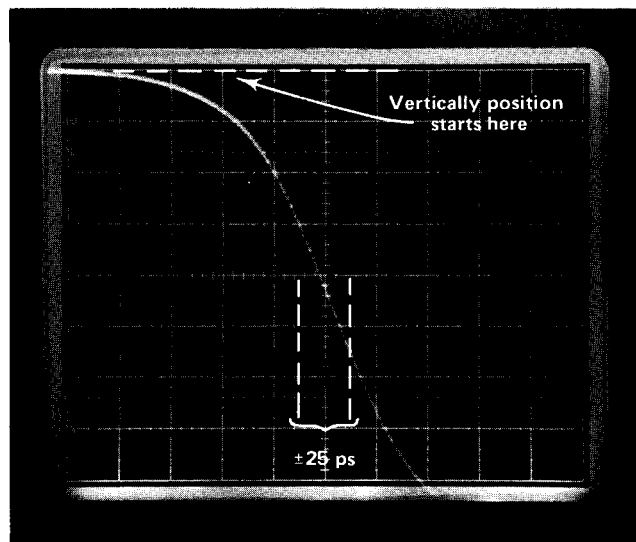

Fig. 6. -INPUT signal.

7A21N

Check Deflection Factor

1. Install the 7A21N into the Calibration Oscilloscope.
2. Set the Square Wave Generator frequency control to approximately 75 kHz. Use the test Oscilloscope to adjust the Square Wave Generator for an output of 10 volts peak-to-peak into 50 Ω .
3. Connect the Square Wave Generator to the 7A21N +INPUT. Terminate the -INPUT into 50 Ω . Check for a CRT display of at least 1 division.
4. Connect the Square Wave Generator to the 7A21N -INPUT. Terminate the +INPUT into 50 Ω . Check for a CRT display of at least 1 division.
5. Change the 7A21N internal connections for single-ended operation.
6. Connect the Square Wave Generator to the 7A21N +INPUT. Terminate the -INPUT into 50 Ω . Check for a CRT display of at least 2.5 cm.

Check Risetime and Aberration

1. Connect the Pulse Generator to obtain a pulse duration of approximately 40 ns by connecting the 20 ns GR cable between the two charge line outputs.
2. Connect the Pulse Generator output to the Delay Line and Trigger Pickoff. Connect the Delay Line output to the 7A21N +INPUT. Connect the Trigger Pickoff to the external trigger input of the Time Base unit.
3. Adjust the Pulse Generator to obtain a six-division display. Set the triggering controls for a stable display.

4. Check that the risetime of the display is less than 465 ps².
5. Check that the aberrations are +4%, -6%, 8% peak-to-peak or less.
6. Change the 7A21N internal connections to obtain differential operation. Terminate the -INPUT into 50 Ω .
7. Connect the Pulse Generator to the 7A21N +INPUT and adjust for a 6 division display.
8. Check that the risetime of the display is less than 465 ps².
9. Check that the aberrations are 10% peak-to-peak or less.
10. Connect the Pulse Generator to the 7A21N -INPUT. Terminate the +INPUT into 50 Ω .
11. Check that the risetime of the display is less than 465 ps².

12. Check that the aberrations are 10% peak-to-peak or less.

²This value was calculated from the formula where: Tr_{PG} is the risetime of the pulse generator; Tr_{DL} is the risetime of the delay line; and Tr_{system} is the risetime of the 7A21N/7904 system.

$$Tr = \sqrt{(Tr_{PG})^2 + (Tr_{DL})^2 + (Tr_{system})^2}$$

OR

$$Tr = \sqrt{250^2 + 175^2 + 350^2}$$

ELECTRICAL PARTS LIST

Replacement parts should be ordered from the Tektronix Field Office or Representative in your area. Changes to Tektronix products give you the benefit of improved circuits and components. Please include the instrument type number and serial number with each order for parts or service.

ABBREVIATIONS AND REFERENCE DESIGNATORS

A	Assembly, separable or repairable	FL	Filter	PTM	paper or plastic, tubular molded
AT	Attenuator, fixed or variable	H	Heat dissipating device (heat sink, etc.)	R	Resistor, fixed or variable
B	Motor	HR	Heater	RT	Thermistor
BT	Battery	J	Connector, stationary portion	S	Switch
C	Capacitor, fixed or variable	K	Relay	T	Transformer
Cer	Ceramic	L	Inductor, fixed or variable	TP	Test point
CR	Diode, signal or rectifier	LR	Inductor/resistor combination	U	Assembly, inseparable or non-repairable
CRT	cathode-ray tube	M	Meter	V	Electron tube
DL	Delay line	Q	Transistor or silicon-controlled rectifier	Var	Variable
DS	Indicating device (lamp)	P	Connector, movable portion	VR	Voltage regulator (zener diode, etc.)
Elect.	Electrolytic	PMC	Paper, metal cased	WW	wire-wound
EMC	electrolytic, metal cased	PT	paper, tubular	Y	Crystal
EMT	electrolytic, metal tubular				
F	Fuse				

Ckt. No.	Tektronix Part No.	Serial/Model No. Eff	Disc	Description
ASSEMBLY	670-2207-00			MAIN Circuit Board Assembly
CAPACITORS				
C5	283-0278-00			2.2 μ F, Cer, 100 V, 20%
C18	283-0278-00			2.2 μ F, Cer, 100 V, 20%
C24	283-0047-00			270 pF, Cer, 500 V, 5%
C25	283-0047-00			270 pF, Cer, 500 V, 5%
C41	283-0047-00			270 pF, Cer, 500 V, 5%
C42	283-0047-00			270 pF, Cer, 500 V, 5%
C61	283-0047-00			270 pF, Cer, 500 V, 5%
C62	283-0047-00			270 pF, Cer, 500 V, 5%
CONNECTORS				
J1, J3	017-0093-01			Adapter, GR to Tek connector
J5	131-1003-00			Receptacle, coaxial cable
J6	131-1003-00			Receptacle, coaxial cable
J7	131-1003-00			Receptacle, coaxial cable
J8	131-1003-00			Receptacle, coaxial cable
J10 ¹				
J11 ¹				
J12 ¹				
J14, J16	017-0093-01			Adapter, GR to Tek connector
J18	131-1003-00			Receptacle, coaxial cable
J20	131-1003-00			Receptacle, coaxial cable
J24	131-1003-00			Receptacle, coaxial cable
J27	131-1003-00			Receptacle, coaxial cable

¹Furnished as a unit with U30

ELECTRICAL PARTS LIST (cont)

Ckt. No.	Tektronix Part No.	Serial/Model No. Eff	Disc	Description
CONNECTORS (cont)				
J29 ¹				
J30 ¹				
J31 ¹				
J33	131-1003-00			Receptacle, coaxial cable
J35	131-1003-00			Receptacle, coaxial cable
J37	131-1003-00			Receptacle, coaxial cable
J39	131-1003-00			Receptacle, coaxial cable
J41	131-1003-00			Receptacle, coaxial cable
J53	131-1003-00			Receptacle, coaxial cable
J55	131-1003-00			Receptacle, coaxial cable
J57	131-1003-00			Receptacle, coaxial cable
J59	131-1003-00			Receptacle, coaxial cable
J61	131-1003-00			Receptacle, coaxial cable
INDUCTORS				
L6	119-0370-00			Balun, 50 Ω , normalizer
L21	119-0397-00			Balun, 50 Ω , inverter (input)
L26	108-0182-00			0.3 μ H
L36	119-0370-00			Balun, 50 Ω , normalizer
L43	108-0182-00			0.3 μ H
L56	119-0369-00			Balun, 50 Ω , inverter
L63	108-0182-00			0.3 μ H
RESISTORS				
U12 ²	307-0397-00			Resistor, thick film, 50 Ω , bridge
R24	307-0023-00			4.7 Ω , 1/2 W, 10%
R25	307-0023-00			4.7 Ω , 1/2 W, 10%
R26	315-0431-00	B010100	B010160	430 Ω , 1/4 W, 5%
R26 ₃	315-0271-00	B010161		270 Ω , 1/4 W, 5%
U30 ³	307-0378-00			Resistor, thick film, power divider
R41	307-0059-00	B010100	B010160	6.2 Ω , 1/2 W, 5%
R41	307-0056-00	B010161		4.3 Ω , 1/2 W, 5%
R42	307-0059-00	B010100	B010160	6.2 Ω , 1/2 W, 5%
R42	307-0056-00	B010161		4.3 Ω , 1/2 W, 5%
R43	315-0431-00	B010100	B010160	430 Ω , 1/4 W, 5%
R43	315-0301-00	B010161		300 Ω , 1/4 W, 5%
R61	307-0059-00	B010100	B010160	6.2 Ω , 1/2 W, 5%
R61	307-0056-00	B010161		4.3 Ω , 1/2 W, 5%
R62	307-0059-00	B010100	B010160	6.2 Ω , 1/2 W, 5%
R62	307-0056-00	B010161		4.3 Ω , 1/2 W, 5%
R63	315-0431-00	B010100	B010161	430 Ω , 1/4 W, 5%
R63	315-0301-00	B010161		300 Ω , 1/4 W, 5%
R95	315-0222-00			2.2 k Ω , 1/4 W, 5%
R96	311-1473-00			2 x 5 k Ω , Var
R99	311-0978-00			250 Ω , Var

¹Furnished as a unit with U30

²Furnished as a unit with J10, J11, & J12.

³Furnished as a unit with J29, J30, & J31.

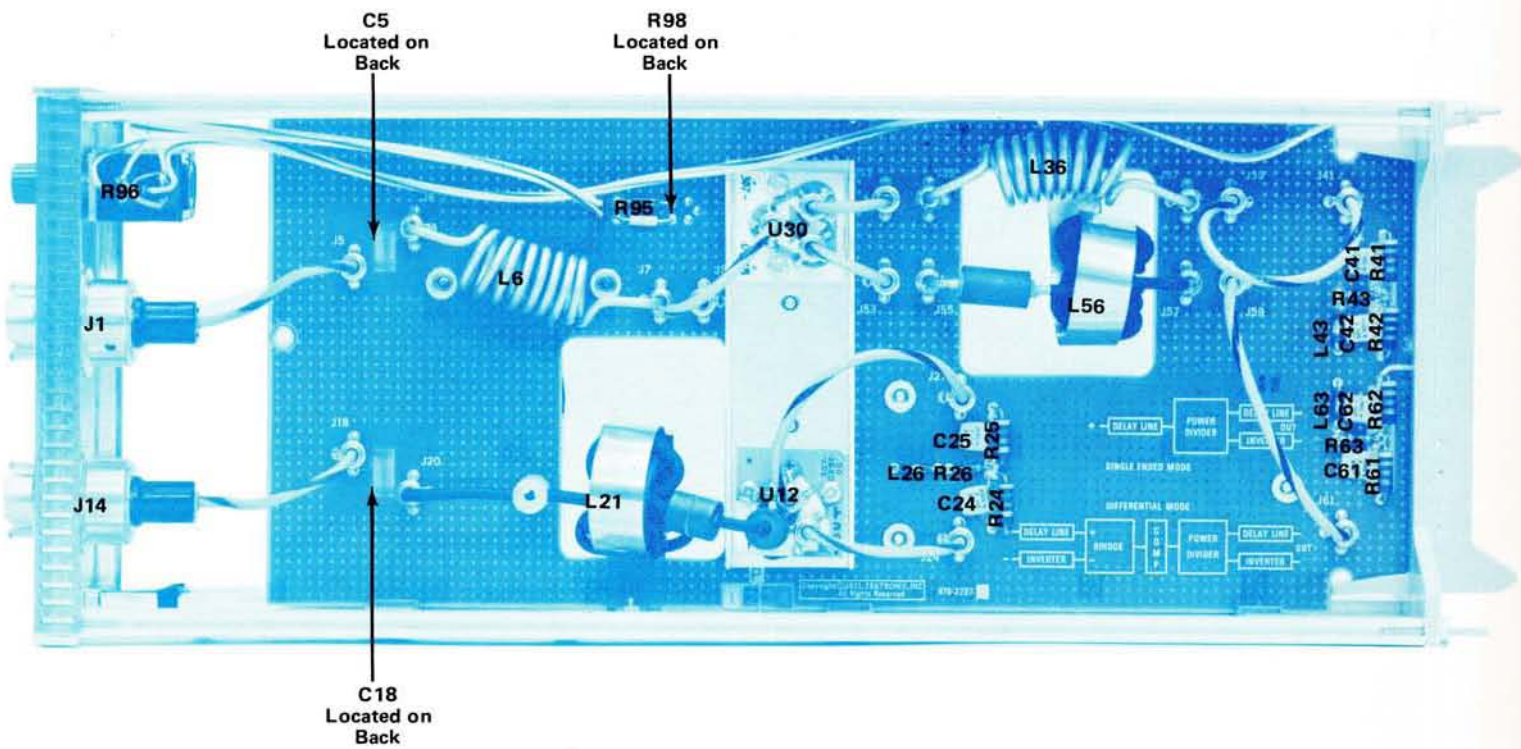

7A21N component location.

Ⓐ

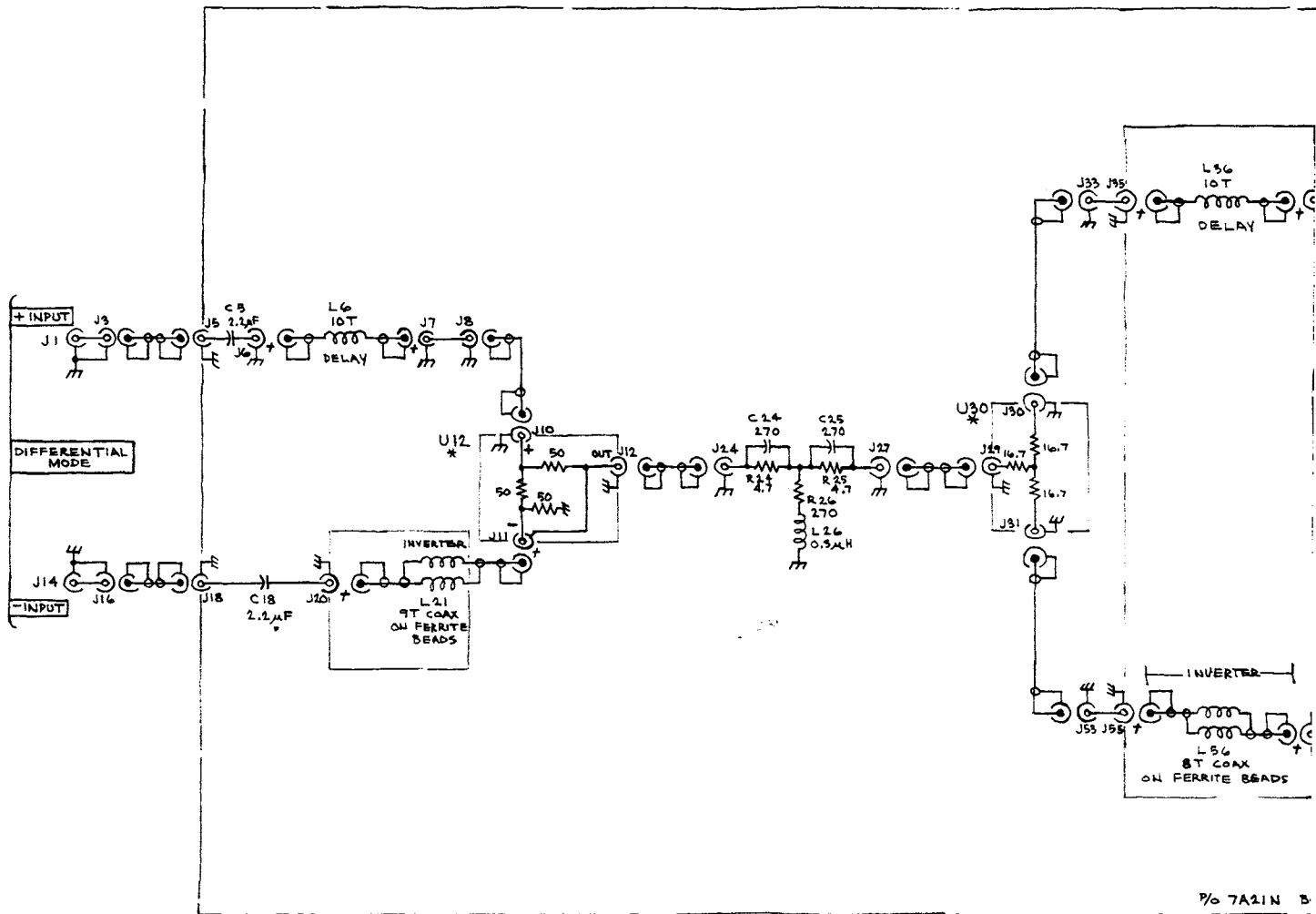

7A21N B

* HYBRID CIRCUIT ON HEAT SINK

† CONN SOLDERED TO PCB

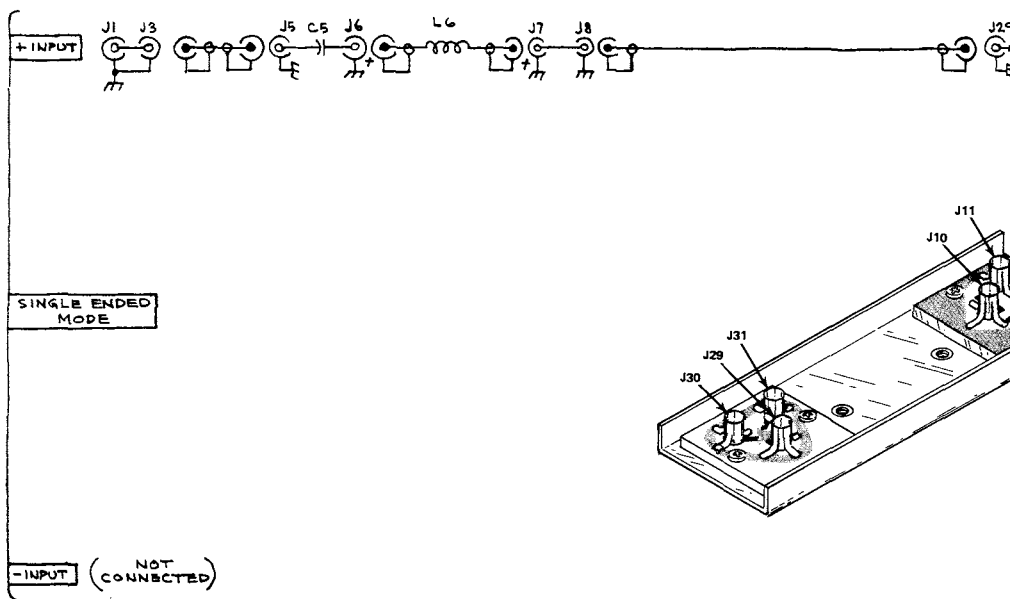

7A21N

(A)

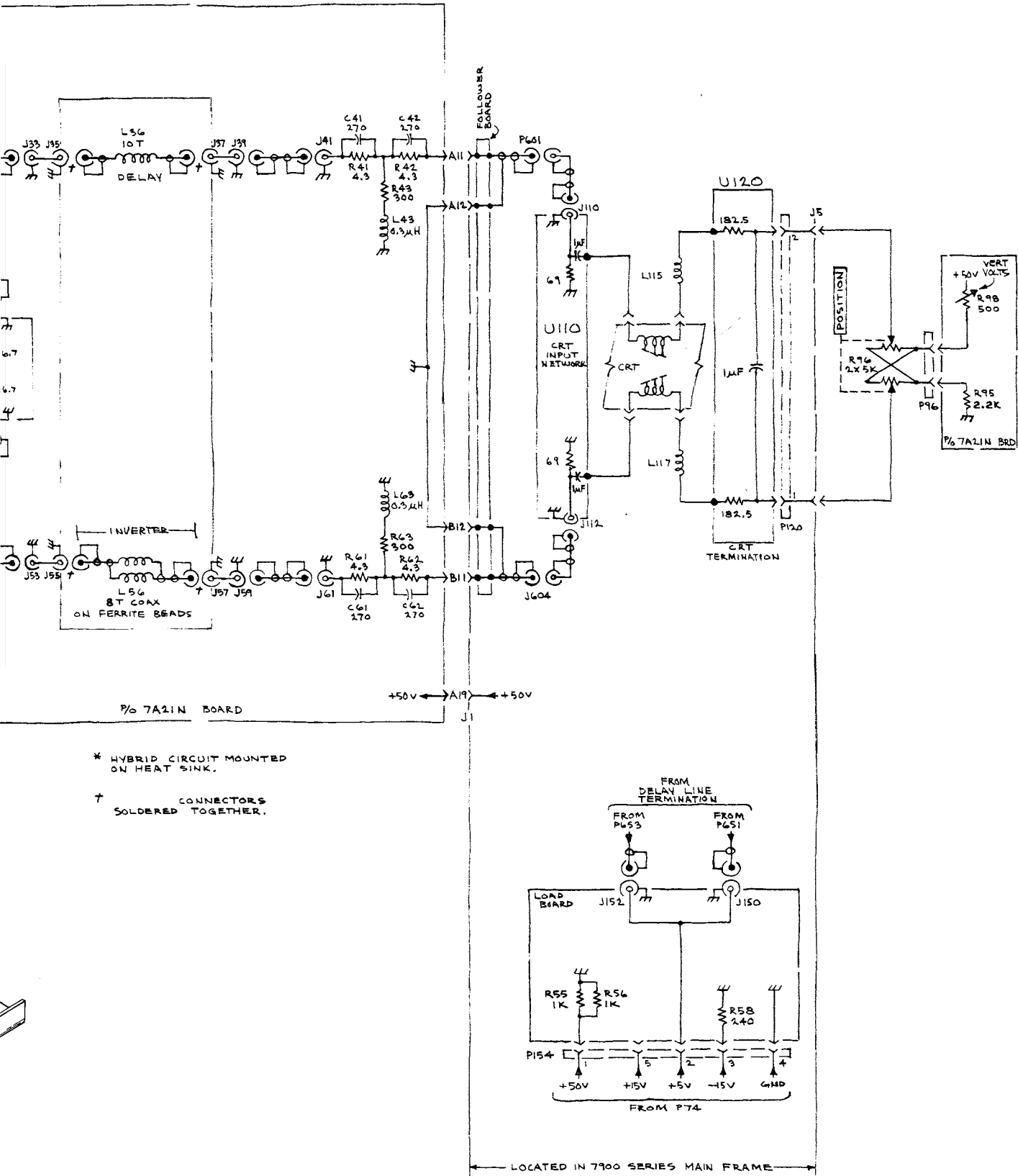

MECHANICAL PARTS LIST

Replacement parts should be ordered from the Tektronix Field Office or Representative in your area. Changes to Tektronix products give you the benefit of improved circuits and components. Please include the instrument type number and serial number with each order for parts or service.

ABBREVIATIONS

BHB	binding head brass	h	height or high	OHB	oval head brass
BHS	binding head steel	hex.	hexagonal	OHS	oval head steel
CRT	cathode-ray tube	HHB	hex head brass	PHB	pan head brass
csk	countersunk	HHS	hex head steel	PHS	pan head steel
DE	double end	HSB	hex socket brass	RHS	round head steel
FHB	flat head brass	HSS	hex socket steel	SE	single end
FHS	flat head steel	ID	inside diameter	THB	truss head brass
Fil HB	fillister head brass	lg	length or long	THS	truss head steel
Fil HS	fillister head steel	OD	outside diameter	w	wide or width

FIGURE 1 EXPLODED

Fig. & Index No.	Tektronix Part No.	Serial/Model No.		Q t y	Description
		Eff	Disc		
1-1	366-0494-00			1	KNOB--POSITION
	- - - - -			-	knob includes:
	213-0153-00			1	SETSCREW, 5-40 x 0.125 inch, HSS
-2	333-1213-04			1	PANEL, front
-3	- - - - -			1	RESISTOR, variable (see R96 electrical list)
	- - - - -			-	mounting hardware: (not included w/resistor)
-4	210-0583-00			1	NUT, hex., 0.25-32 x 0.312
-5	017-0093-01			2	ADAPTER, GR to Tek connector
	- - - - -			-	mounting hardware for each: (not included w/adapter)
-6	220-0459-00			1	NUT, dodecagon, 0.875-32 x 1.00 inch
-7	210-0047-00			1	WASHER, lock, 0.88 ID x 1.11 inch OD
-8	386-1447-60			1	SUBPANEL, front
	- - - - -			-	mounting hardware: (not included w/subpanel)
-9	213-0192-00			4	SCREW, thread forming, 6-32 x 0.50 inch, Fil HS
-10	366-1058-37			1	KNOB, latch
	- - - - -			-	mounting hardware: (not included w/knob)
-11	214-1095-00			1	PIN, spring
-12	105-0076-00			1	RELEASE BAR, latch
-13	214-1280-00			1	SPRING, helical, extension
-14	214-1061-00			1	SPRING, flat, plug-in
-15	105-0075-00			1	BOLT, latch
-16	348-0235-00			2	SHIELDING GASKET, electronic
-17	344-0211-00			3	CLIP, spring tension
-18	- - - - -			1	RESISTOR, fixed (see U30 electrical list)
	- - - - -			-	mounting hardware: (not included w/resistor)
-19	211-0008-00			2	SCREW, 4-40 x 0.25 inch, PHS

FIGURE 1 EXPLODED (cont)

Fig. & Index No.	Tektronix Part No.	Serial/Model No.		Q t y	Description
		Eff	Disc		
1-20	- - - - -			-	RESISTOR, fixed (see U12 electrical list)
	- - - - -			-	mounting hardware: (not included w/resistor)
-21	211-0008-00			2	SCREW, 4-40 x 0.25 inch, PHS
-22	407-1131-00			1	BRACKET, power divider
	- - - - -			-	mounting hardware: (not included w/bracket)
-23	211-0008-00			2	SCREW, 4-40 x 0.25 inch, PHS
-24	337-1720-00			2	SHIELD, electrical
	- - - - -			-	mounting hardware for each: (not included w/shield)
-25	211-0101-00			1	SCREW, 4-40 x 0.25 inch, 100° csk, FHS
-26	210-0586-00			1	NUT, keps, 4-40 x 0.25 inch
-27	343-0144-00			1	CLAMP, loop, 0.125 diameter
-28	119-0397-00			1	BALUN, 50Ω inverter (L21)
	- - - - -			-	mounting hardware: (not included w/balun)
-29	210-0097-00			1	SCREW, 4-40 x 0.312 inch, PHS
-30	119-0370-00			2	BALUN, 50Ω normalizer (L6,L36)
-31	119-0369-00			1	BALUN, 50Ω inverter (L56)
-32	- - - - -			1	CIRCUIT BOARD ASSEMBLY--DIRECT ACCESS (see electrical list)
	- - - - -			-	list)
	- - - - -			-	circuit board assembly includes:
-33	131-0608-00			2	TERMINAL, pin, 0.365 inch long
-34	131-1003-00			18	CONNECTOR, receptacle, coaxial cable
-35	136-0252-00			18	SOCKET, pin connector
-36	129-0124-00			3	POST, 0.187 OD x 0.148 inch long
-37	129-0204-00	B010100	B010141	2	POST, 0.25 OD x 0.16 inch long
	129-0209-00	B010142		2	POST, 0.25 OD x 0.375 inch long
-38	131-0566-00			1	LINK, terminal connecting
-39	337-1064-04			2	SHIELD, electrical, side
-40	386-1402-00			1	SUBPANEL, rear
	- - - - -			-	mounting hardware: (not included w/subpanel)
-41	213-0192-00			4	SCREW, thread forming, 6-32 x 0.50 inch, Fil HS
-42	361-0326-00			1	SPACER, 0.181D x 0.250D x 0.10 inch long
-43	131-0958-00			2	CONTACT, electrical, male
-44	426-0505-05			1	FRAME SECTION, bottom
-45	344-0210-00			3	CLIP, spring tension
-46	214-1061-00			1	SPRING, flat, sliding ground
-47	426-0499-05			1	FRAME SECTION, top
-48	352-0169-00			1	HOLDER, terminal connector, 2 wire (black)
-49	131-0707-00			2	CONNECTOR, terminal
-50	175-0863-00			ft	WIRE, electrical, 2 wire ribbon, 19 inches
-51	210-0774-00			16	EYELET, 0.152 OD x 0.245 inch long
-52	210-0775-00			16	EYELET, 0.126 OD x 0.23 inch long

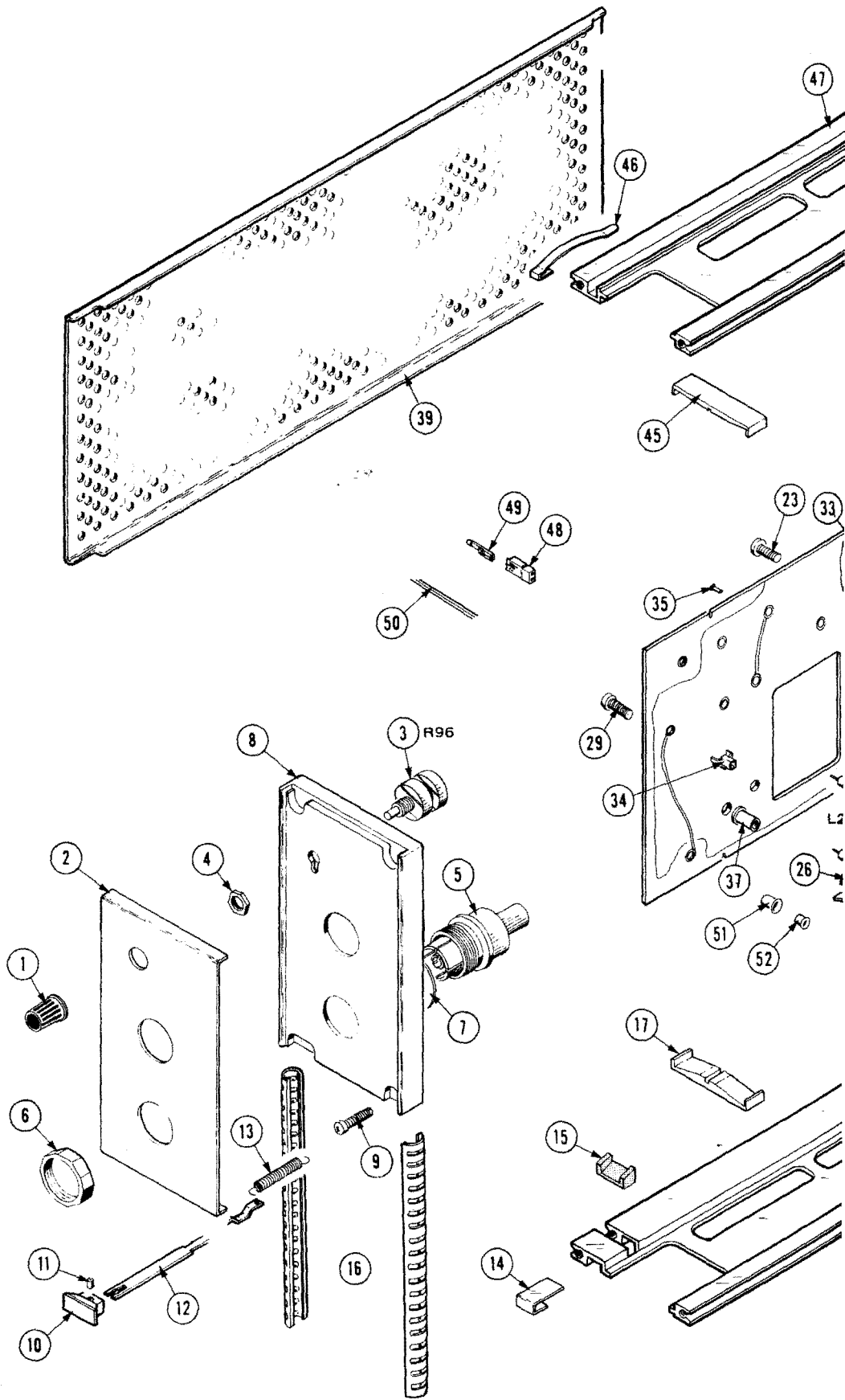

+

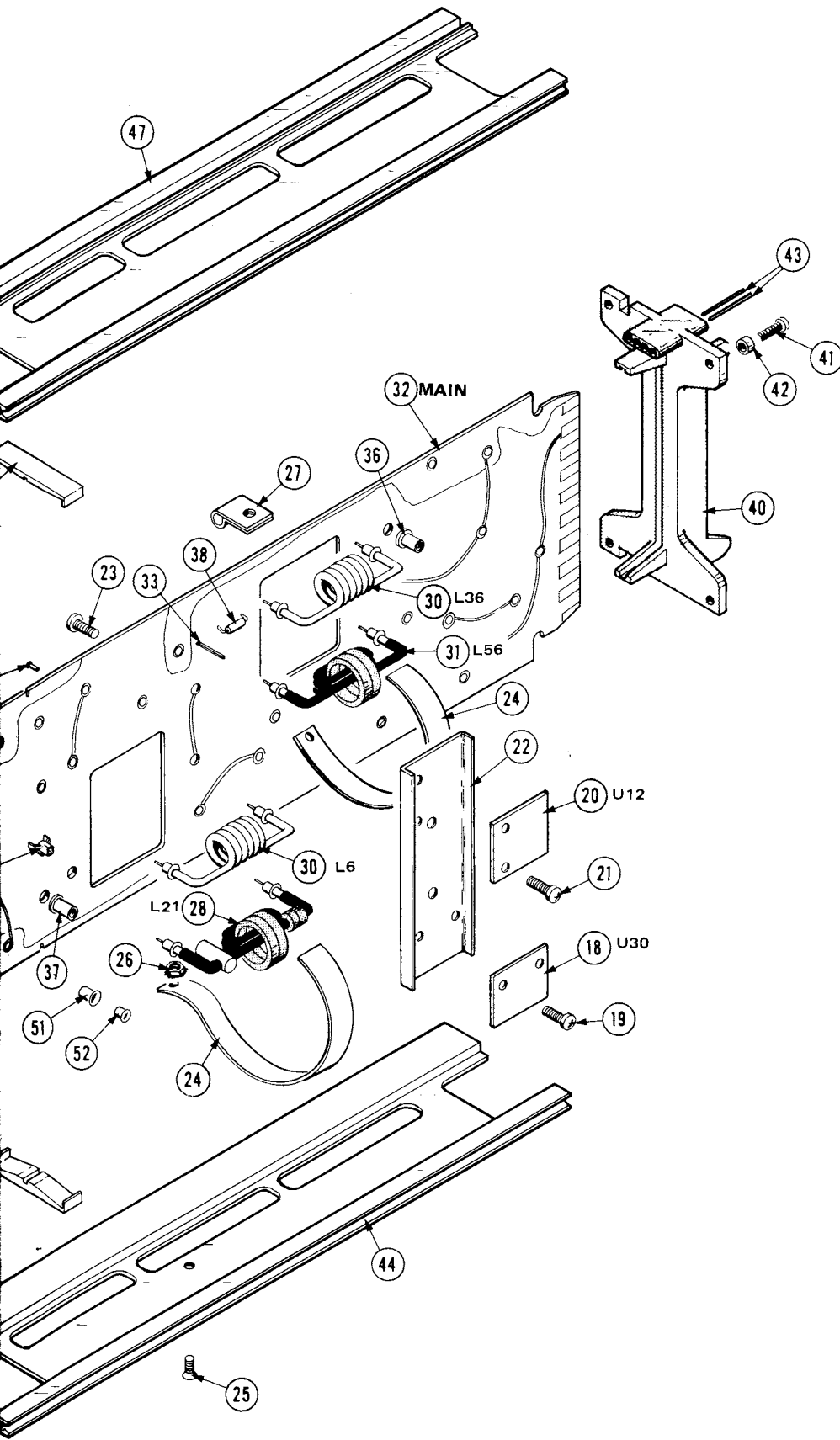

7A21N DIRECT ACCESS

FIG. 2 ACCESSORIES

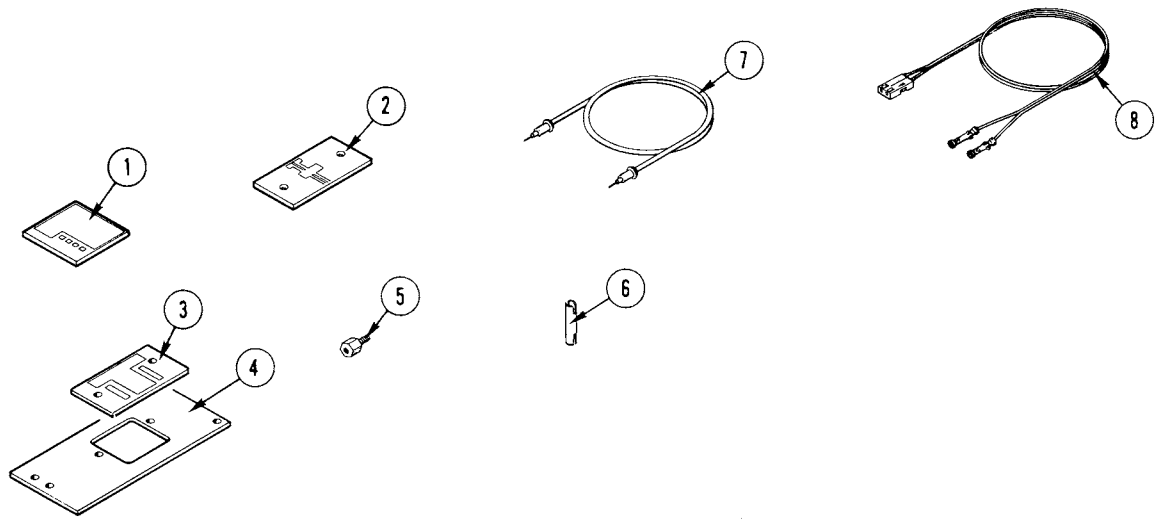

Fig. & Index No.	Tektronix Part No.	Serial/Model No.		Qty	Description
		Eff	Disc		
2-1	670-2287-00			1	COAXIAL TERMINATION
-2	307-0376-00			1	RESISTOR, fixed, thick film
-3	307-0377-00			1	RESISTOR, fixed, thick film
-4	386-2358-00			1	PLATE, mounting
-5	129-0339-00			4	POST, hex, 0.25 x 0.27 inch long
-6	103-0164-00			1	ADAPTER, connector
-7	175-1401-00			1	CABLE ASSEMBLY, special purpose electrical, blue wire, brown stripe
	175-1402-00			1	CABLE ASSEMBLY, special purpose electrical, blue wire, red stripe
-8	175-1403-00			1	CABLE ASSEMBLY, special purpose electrical
	343-0002-00			1	CLAMP, cable, 0.188 inch
	210-0863-00			1	WASHER, loop clamp
	211-0008-00			4	SCREW, 4-40 x 0.312 inch, PHS
	211-0559-00			1	SCREW, 6-32 x 0.375 inch, 100° csk, FHS
	210-0457-00			1	NUT, keps, 6-32 x 0.312 inch

Fig. & Index No.
 3-
 -1
 -2
 -3
 -4

7A21N DIRECT ACCESS

FIG. 3 REPACKAGING

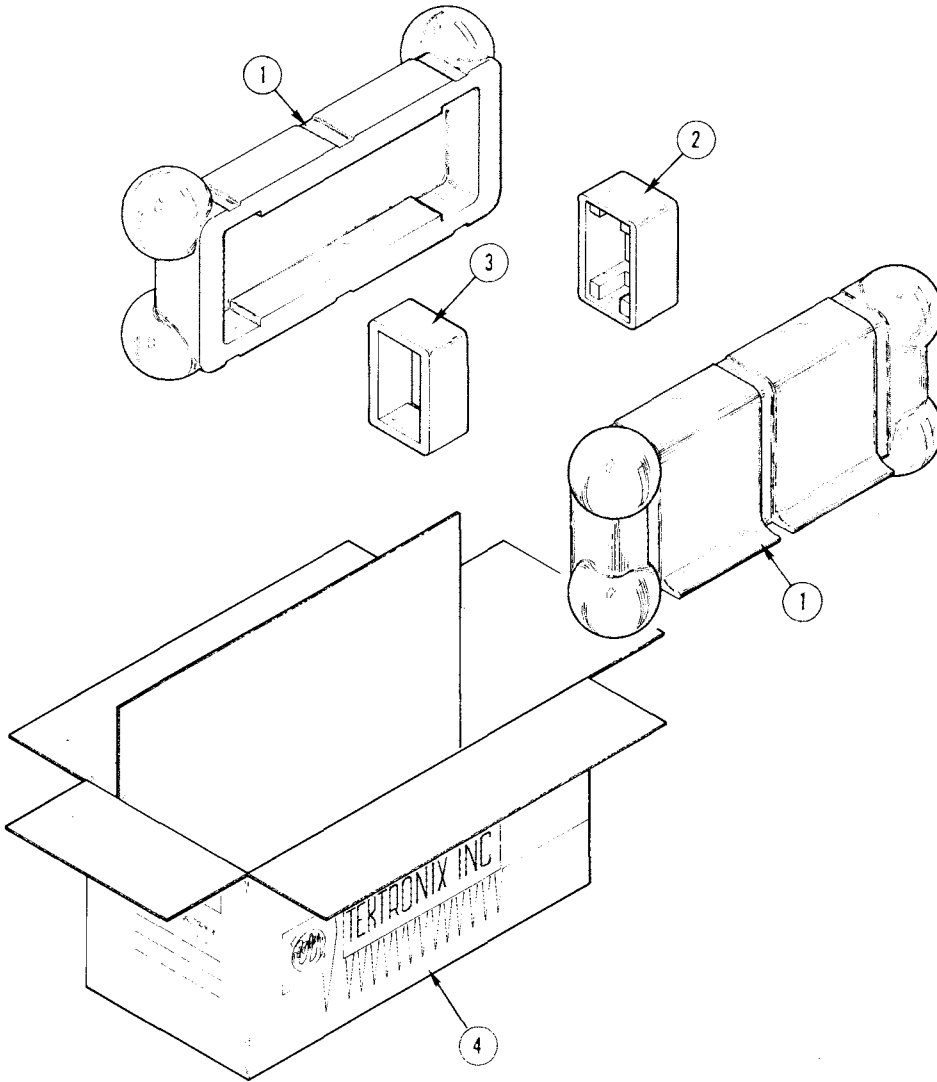

Fig. & Index No.	Tektronix Part No.	Serial/Model No.		Q	y						Description	
		Eff	Disc			1	2	3	4	5		
3-	065-0125-00			1								CARTON ASSEMBLY
	-----			-								Carton assembly includes:
-1	004-0241-00			2								CASE HALF
-2	004-0242-00			1								END CAP, rear
-3	004-0243-00			1								END CAP, front
-4	004-0748-00			1								CARTON

Ⓐ

MANUAL CHANGE INFORMATION

At Tektronix, we continually strive to keep up with latest electronic developments by adding circuit and component improvements to our instruments as soon as they are developed and tested.

Sometimes, due to printing and shipping requirements, we can't get these changes immediately into printed manuals. Hence, your manual may contain new change information on following pages.

A single change may affect several sections. Sections of the manual are often printed at different times, so some of the information on the change pages may already be in your manual. Since the change information sheets are carried in the manual until ALL changes are permanently entered, some duplication may occur. If no such change pages appear in this section, your manual is correct as printed.

Scans By *Artek Media*

Artek Media
1042 Plummer Cir. SW
Rochester, MN 55902

www.artekmedia.com

"High resolution scans of obsolete technical manuals"

If you're looking for a quality scanned technical manual in PDF format please visit our WEB site at www.artekmedia.com or drop us an email at manuals@artekmedia.com and we will be happy to email you a current list of the manuals we have available.

If you don't see the manual you need on the list drop us a line anyway we may still be able to point you to other sources. If you have an existing manual you would like scanned please write for details, This can often be done very reasonably in consideration for adding your manual to our library.

Typically the scans in our manuals are done as follows;

- 1) Typed text pages are typically scanned in black and white at 300 dpi.
- 2) Photo pages are typically scanned in gray scale mode at 600 dpi
- 3) Schematic diagram pages are typically scanned in black and white at 600 dpi unless the original manual had colored high lighting (as is the case for some 70's vintage Tektronix manuals).

If you purchased this manual from us (typically through our Ebay name of ArtekMedia) thank you very much. If you received this from a well-meaning "friend" for free we would appreciate your treating this much like you would "share ware". By that we mean a donation of at least \$5-10 per manual is appreciated in recognition of the time (a manual can take as much as 40 hours to reproduce, book, link etc.), energy and quality of effort that went into preserving this manual. Donations via PayPal go to: manuals@artekmedia.com or can be mailed to us the address above.

Thanks



Dave & Lynn Henderson
Artek Media