

INSTRUCTION MANUAL

7B71

**DELAYING
TIME BASE**



MANUFACTURERS OF CATHODE-RAY OSCILLOSCOPES

Scans By *Artek Media*

Artek Media
1042 Plummer Cir. SW
Rochester, MN 55902

www.artekmedia.com

"High resolution scans of obsolete technical manuals"

If your looking for a quality scanned technical manual in PDF format please visit our WEB site at www.artekmedia.com or drop us an email at manuals@artekmedia.com and we will be happy to email you a current list of the manuals we have available.

If you don't see the manual you need on the list drop us a line anyway we may still be able to point you to other sources. If you have an existing manual you would like scanned please write for details, This can often be done very reasonably in consideration for adding your manual to our library.

Typically the scans in our manuals are done as follows;

- 1) Typed text pages are typically scanned in black and white at 300 dpi.
- 2) Photo pages are typically scanned in gray scale mode at 600 dpi
- 3) Schematic diagram pages are typically scanned in black and white at 600 dpi unless the original manual had colored high lighting (as is the case for some 70's vintage Tektronix manuals).

If you purchased this manual from us (typically through our Ebay name of ArtekMedia) thank you very much. If you received this from a well-meaning "friend" for free we would appreciate your treating this much like you would "share ware". By that we mean a donation of at least \$5-10 per manual is appreciated in recognition of the time (a manual can take as much as 40 hours to reproduce, book, link etc.), energy and quality of effort that went into preserving this manual. Donations via PayPal go to: manuals@artekmedia.com or can be mailed to us the address above.

Thanks



Dave & Lynn Henderson
Artek Media



WARRANTY

All Tektronix instruments are warranted against defective materials and workmanship for one year. Tektronix transformers, manufactured in our plant, are warranted for the life of the instrument.

Any questions with respect to the warranty mentioned above should be taken up with your Tektronix Field Engineer.

Tektronix repair and replacement-part service is geared directly to the field, therefore all requests for repairs and replacement parts should be directed to the Tektronix Field Office or representative in your area. This procedure will assure you the fastest possible service. Please include the instrument Type and Serial or Model Number with all requests for parts or service.

Specifications and price change privileges reserved.

Copyright© 1970 by Tektronix, Inc., Beaverton, Oregon. Printed in the United States of America. All rights reserved. Contents of this publication may not be reproduced in any form without permission of the copyright owner.

TABLE OF CONTENTS

	Page
SECTION 1	SPECIFICATIONS
	Introduction 1-1
	Electrical Characteristics 1-1
	Sweep Rate 1-1
	Sweep Accuracy 1-1
	Sweep Length 1-1
	Sweep Hold-Off Time 1-1
	Variable Time Delay 1-1
	Delay Time Accuracy 1-1
	Multiplier Incremental Linearity 1-1
	Jitter 1-1
	Differential Time Measurement Accuracy 1-2
	Trigger Sensitivity 1-2
	Internal Trigger Jitter 1-2
	External Trigger Input 1-2
	Level Range 1-2
	P-P Auto Sensitivity 1-2
	Environmental Characteristics
	Altitude 1-2
	Physical Characteristics
	Finish 1-2
	Dimensions 1-2
	Weight 1-2
SECTION 2	OPERATING INSTRUCTIONS
	General 2-1
	Installation 2-1
	Front Panel Controls 2-1
	Test Setup Chart 2-4
	General Operating Information 2-4
	Sweep Calibration Check 2-4
	Simplified Operating Instructions 2-6
	Normal Sweep 2-6
	Magnified Sweep 2-6
	Delayed Sweep 2-6
	Pushbutton Switch Logic 2-6
	Triggered Light 2-7
	Trigger Mode 2-7
	Trigger Coupling 2-9
	Trigger Source 2-10
	Trigger Slope 2-10
	Trigger Level 2-10
	Horizontal Sweep Rate 2-12
	Sweep Magnifier 2-12
	Horizontal Position Control 2-13

TABLE OF CONTENTS (cont)

		Page
SECTION 2	OPERATING INSTRUCTIONS (cont)	
	Applications	2-13
	General	2-13
	Measurement Techniques	2-13
	Time Duration Measurements	2-14
	Determining Frequency	2-15
	Risetime Measurements	2-15
	Delay Sweep Time Measurements	2-16
	Delayed Sweep Magnification	2-17
	Displaying Complex Signals Using Delayed Sweep	2-18
	Pulse Jitter Measurements	2-18
SECTION 3	CIRCUIT DESCRIPTION	
	Introduction	3-1
	Block Diagram Description	3-1
	Detailed Circuit Description	3-1
	Trigger Input	3-1
	Input Source	3-1
	Trigger Amplifier	3-2
	General	3-2
	External Input Amplifier	3-2
	Input Stage	3-2
	Peak Detector	3-3
	Slope Comparator	3-3
	Output Stage	3-4
	Trigger Generator	3-4
	Trigger Pulse Generator	3-4
	Sweep Gate Stage	3-4
	Triggered Hold-Off Stage	3-4
	Bright Line Auto	3-5
	Time-Base Generator	3-5
	General	3-5
	Normal Trigger Mode Operation	3-5
	Single Sweep Operation	3-8
	Alternate Operation	3-8
	Delayed Sweep Operation	3-8
	Delay Pickoff	3-9
	Horizontal Preamp	3-9
	Readout Block	3-9
SECTION 4	MAINTENANCE	
	Preventive Maintenance	4-1
	General	4-1
	Cleaning	4-1
	Visual Inspection	4-1
	Transistor and Integrated Circuit Checks	4-1
	Recalibration	4-1

TABLE OF CONTENTS (cont)

SECTION 4	MAINTENANCE (cont)	Page
	Troubleshooting	4-2
	Troubleshooting Aids	4-2
	Troubleshooting Equipment	4-2
	Troubleshooting Techniques	4-2
	Corrective Maintenance	4-6
	General	4-6
	Obtaining Replacement Parts	4-6
	Soldering Techniques	4-7
	Component Replacement	4-7
	Instrument Repackaging	4-10
SECTION 5	PERFORMANCE CHECK/CALIBRATION	
	Introduction	5-1
	Test Equipment Required	5-1
	Short-Form Procedure and Index	5-2
	Performance Check/Calibration Procedure	5-4
	General	5-4
	Preliminary Control Settings	5-5
	Check/Adjust Steps (refer to Short-Form Procedure for index to steps)	5-6
SECTION 6	ELECTRICAL PARTS LIST	
	Abbreviations and Symbols	
	Parts Ordering Information	
	Index of Electrical Parts List	
SECTION 7	DIAGRAMS AND MECHANICAL PARTS ILLUSTRATIONS	
	Diagrams	
	Mechanical Parts Illustrations	
SECTION 8	MECHANICAL PARTS LIST	
	Mechanical Parts List Information	
	Index of Mechanical Parts Illustrations	
	Mechanical Parts List	
	Accessories	

CHANGE INFORMATION

Abbreviations and symbols used in this manual are based on or taken directly from IEEE Standard 260 "Standard Symbols for Units", MIL STD-12B and other standards of the electronics industry. Change information, if any, is located at the rear of this manual.

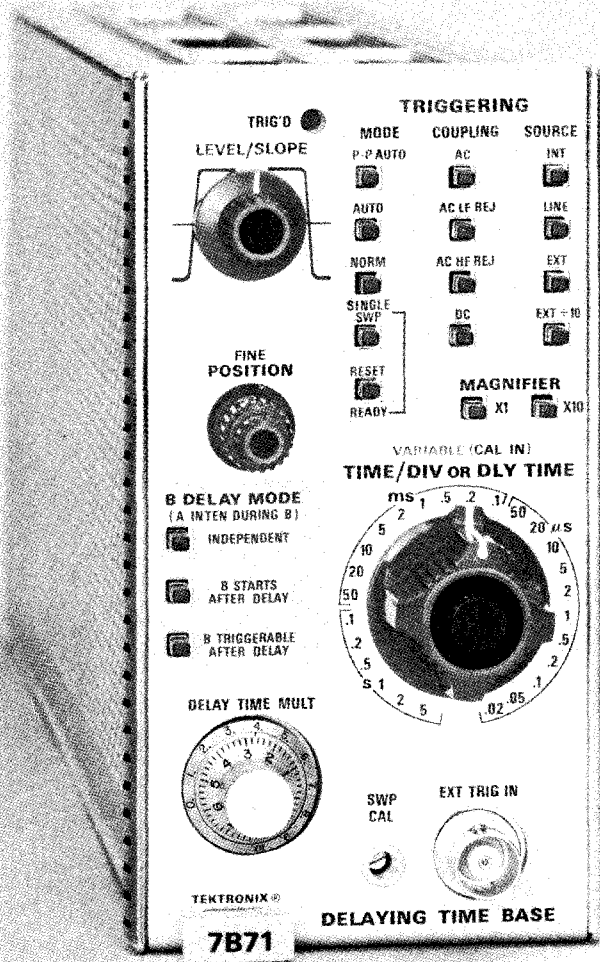

Fig. 1-1. 7B71 Delaying Time Base.

SECTION 1

7B71 SPECIFICATION

Change information, if any, affecting this section will be found at the rear of the manual.

Introduction

The 7B71 Time Base Unit is designed specifically for use with Tektronix 7700-Series Oscilloscopes. However, it is compatible with all 7000-Series Oscilloscopes. The 7B71 provides calibrated sweeps from 5 seconds/division to 0.02 microseconds/division (2 nanoseconds/division with X10 MAGNIFIER). Sweep rates may be varied continuously (uncalibrated) between calibrated steps. Sweep triggering is to 200 megahertz or vertical amplifier bandwidth, whichever is less. The delaying sweep feature of the 7B71, in delayed sweep operation, gives continuous sweep delay from 0 to 10 times the setting of the TIME/DIV OR DLY

TIME selector. The sweep free-runs providing a bright baseline in the absence of adequate triggering signal in P-P AUTO and AUTO triggering modes.

The Performance Check procedure given in Section 5 of this manual provides a convenient method of checking performance of this instrument. The following electrical characteristics apply at an ambient temperature of 0°C to +50°C, unless otherwise noted. Warmup time for given accuracy is 20 minutes.

TABLE 1-1
Electrical Characteristics

Characteristic	Performance			
Sweep Rate Calibrated Range	5 seconds/division to 0.02 microseconds/division in a 1-2-5 sequence. X10 magnifier extends sweep rate to 2 nanoseconds/division.			
VARIABLE Range (uncalibrated)	Continuously variable between calibrated sweep rates. Extends uncalibrated sweep rate to at least 12.5 seconds/division.			
Sweep Accuracy Time Interval	Measured in 7700 series mainframe			
	+15°C to +35°C		0°C to +50°C	
Over Center 8 div	Unmag	Mag	Unmag	Mag
5 s/div to 0.1 s/div and 0.2 μs/div to 0.02 μs/div	3%	3.5%	4%	5%
50 ms/div to 0.5 μs/div	2%	2.5%	3%	4%
Over any 2 div interval within center 8 div	5%		7%	

Characteristic	Performance
Exclude Following Portions of Magnified Sweep	Start of Sweep; 50 ns End of Sweep; beyond 100 divisions
Sweep Length	10 divisions to 13 divisions. s.
Sweep Hold-Off Time	1.5 times the TIME/DIVISION setting or less.
5 s/div to 5 μs/div	
2 μs/div to 0.02 μs/div	3.5 microseconds or less.
Variable Time Delay Delay Time Accuracy	Within 2%
5 s/div to 1 s/div	
0.5 s/div to 1 μs/div	Within 1%
Multiplier Incremental Linearity	Within 0.2%
Jitter	1 part or less in 50,000 of 10 times the TIME/DIV setting

TABLE 1-1 (cont)

Characteristic	Performance		
Differential Time Measurement Accuracy	Within 1% and 2 minor divisions		
Delay Time 1 μ s to 0.5 s			
1 s to 5 s	Within 2% and 2 minor divisions		
Trigger Sensitivity	Triggering Frequency Range ¹	Minimum Triggering Signal Required	
Coupling		INT	EXT
AC	30 Hz to 20 MHz	0.3 div	75 mV
	20 MHz to 200 MHz	1.5 div	375 mV
AC LF REJ ²	30 kHz to 20 MHz	0.3 div	75 mV
	20 MHz to 200 MHz	1.5 div	375 mV
AC HF REJ	30 Hz to 50 kHz	0.3 div	75 mV
DC	DC to 20 MHz	0.3 div	75 mV
	20 MHz to 200 MHz	1.5 div	375 mV
Single Sweep	Triggering requirements same as normal sweep. When triggered, sweep generator produces one sweep only.		
Internal Trigger Jitter	1 nanosecond or less at 150 megahertz.		
External Trigger Input Maximum Input Voltage	500 volts (DC + Peak AC). 500 volts (P-P AC) at 1 kilohertz or less.		

¹ On Internal Triggering Only; the specified upper –3 dB frequency of the Vertical System replaces upper limit frequencies in the above table when the number in the table is greater than the –3 dB frequency of the Vertical System.

² Will not trigger on sine waves of 3 divisions or less internal or 1.5 volts external below 120 Hz.

TABLE 1-1 (cont)

Characteristic	Performance
Input R and C	1 megohm within 2%, 20 picofarads within 2 picofarads.
Level Range (Excluding P-P AUTO) EXT EXT \div 10	At least +1.5 volts to –1.5 volts. At least +15 volts to –15 volts.
P-P AUTO operation Sensitivity	0.5 div Internal, 125 millivolts External 200 Hz to 20 MHz. Upper frequency and amplitude limits same as NORMAL Trigger Sensitivity.
Low Frequency Response	Must Trigger on 50 hertz, 2 division signal.

TABLE 1-2

Environmental Characteristics

This instrument will meet the electrical characteristics given in Table 1-1 over the following environmental limits.

Characteristic	Performance
Altitude Non-operating	To 50,000 feet and –55°C.

TABLE 1-3

Physical Characteristics

Finish Dimensions	Front panel is anodized aluminum. Fits single plug-in compartment of 7000-series oscilloscope.
Weight	Approximately 2.88 pounds.

SECTION 2

OPERATING INSTRUCTIONS

Change information, if any, affecting this section will be found at the rear of the manual.

General

The 7B71 delaying sweep plug-in unit operates with a Tektronix 7000-series indicator oscilloscope and a 7A-series vertical plug-in unit to form a complete oscilloscope system. To use the 7B71 effectively, its operation and capabilities should be known. This section describes the operation of the front-panel controls, gives first-time and general operating information and lists some basic applications for this instrument.

Installation

The 7B71 is designed to operate in the horizontal plug-in compartments of Tektronix 7000-series oscilloscopes. The 7B71 can also be installed in a vertical plug-in compartment to provide a sweep that runs vertically on the CRT. However, when used in this manner, there is no retrace blanking or internal triggering provision and the unit may not meet the specifications given in Section 1. The instructions in this manual are written for use of the 7B71 in a horizontal plug-in compartment of the oscilloscope.

When the 7B71 is used with an oscilloscope which has two horizontal plug-in compartments, install this unit in the A (DELAYING TIME BASE) compartment. Then, if a delayed-sweep unit is installed in the B (right) compartment, delayed-sweep operation is available. The 7B71 will operate properly in the B compartment for all horizontal modes of operation except delaying sweep.

To install the 7B71 into a plug-in compartment, push it in until it fits firmly into the indicator plug-in compartment. To remove, pull the release latch (see Fig. 2-1) to disengage the unit from the indicator and pull it out of the plug-in compartment. Even though the horizontal gain of the indicator oscilloscope is standardized to minimize adjustment when inserting plug-in units, the sweep calibration of the 7B71 should be checked when it is inserted into the indicator to verify measurement accuracy. The procedure for checking the unit is given under Sweep Calibration Check in this section.

FRONT-PANEL CONTROLS

General

All controls required for the operation of the 7B71 are located on the front panel of the unit (see Fig. 2-2). To

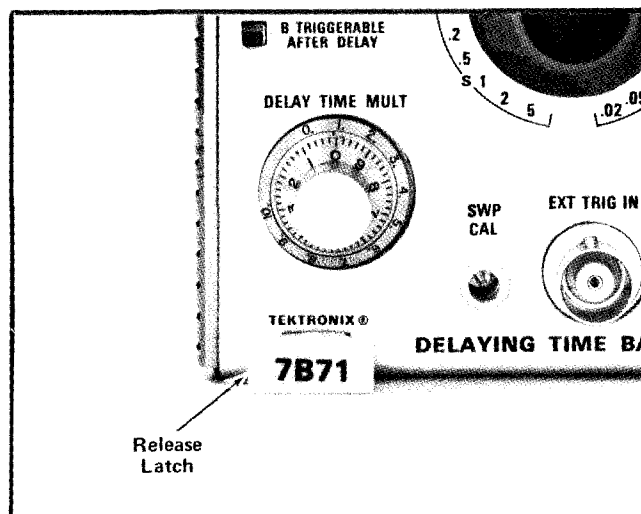

Fig. 2-1. Location of release latch.

make full use of the capabilities of this instrument, the operator should be familiar with the function and use of each of these controls. A brief description of the front-panel controls and connector is given here. More detailed information is given under General Operating Information.

Triggering Controls

LEVEL/SLOPE

Selects the amplitude point and slope of trigger signal on which the sweep is triggered. When the indicator line on the outer ring is to the left of center, the sweep is triggered on the positive-going slope of the trigger signal, as shown by the positive-going waveform. To the right of center, the sweep is triggered on the negative-going slope of the trigger signal as shown by the negative-going waveform.

TRIG'D

Light indicates that the sweep is triggered and will produce a display with correct setting of the POSITION control and the controls on the associated vertical unit and indicator oscilloscope.

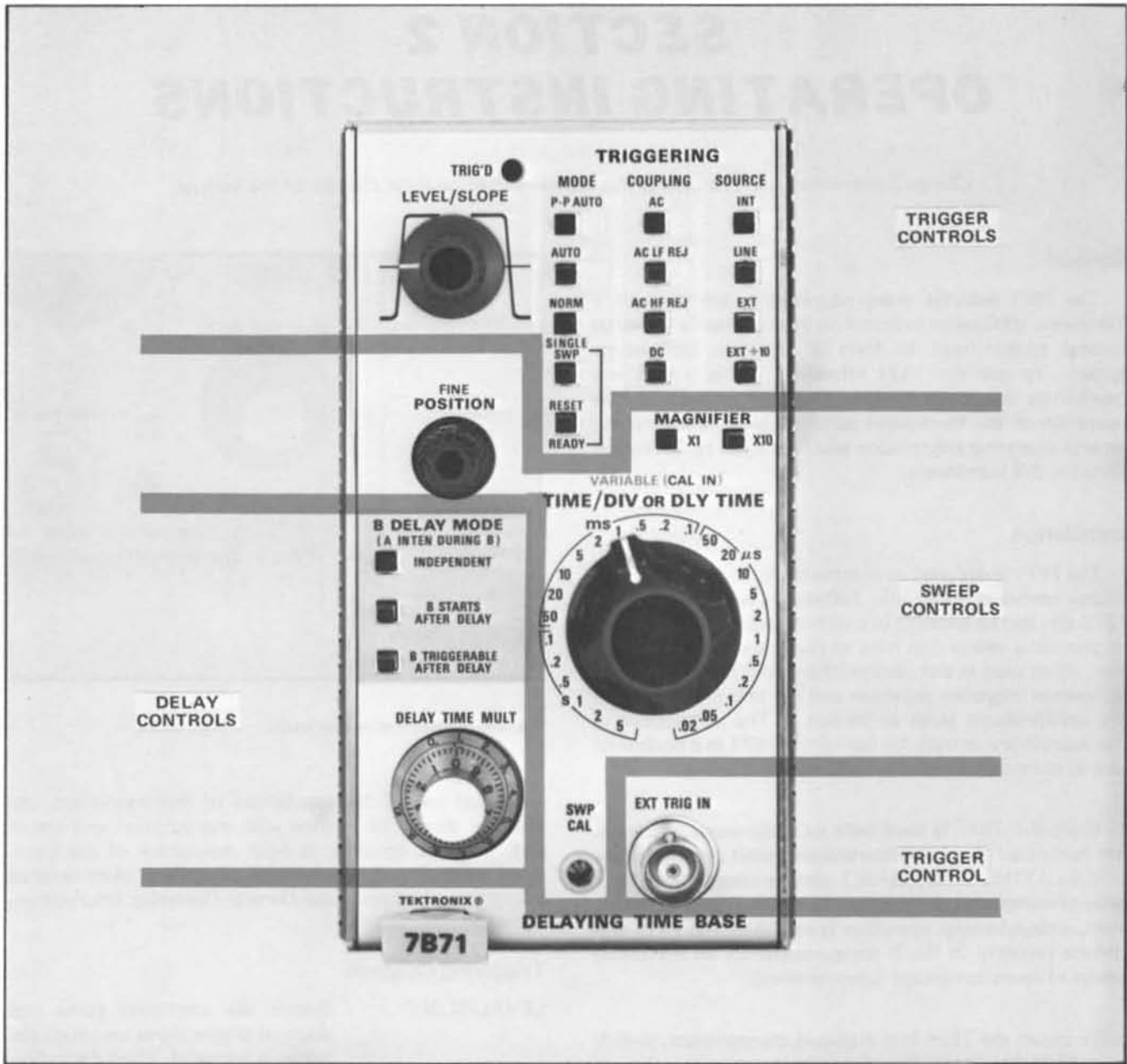

Fig. 2-2. Front-Panel controls and connectors.

MODE

Series of push-button switches to select the trigger mode. Selected mode is indicated by lighted button.

P-P AUTO: Sweep automatically triggered at point selected by the LEVEL/SLOPE control when the trigger signal repetition rate is above about 200 hertz and within the frequency range

selected by the COUPLING switch. Triggered sweep can be obtained throughout the range of the LEVEL/SLOPE control. When the trigger repetition rate is below the lower frequency limit (or above upper limit for AC HF REJ) or when the trigger signal is inadequate, the sweep free runs at the sweep rate selected by the TIME/DIV switch to produce a reference trace.

AUTO: Sweep initiated by the applied trigger signal at point selected by the LEVEL/SLOPE control when the trigger signal repetition rate is above about 30 hertz and within the frequency range selected by the COUPLING switch. Triggered sweep can be obtained only over the amplitude range of the applied trigger signal. When the LEVEL/SLOPE control is outside the amplitude range, the trigger repetition rate is below the lower frequency limit (or above upper limit for AC HF REJ) or the trigger signal is inadequate, the sweep free runs at the sweep rate selected by the TIME/DIV switch to produce a reference trace.

NORM: Sweep initiated by the applied trigger signal at any point selected by the LEVEL/SLOPE control over the frequency range selected by the COUPLING switch. Triggered sweep can be obtained only over the amplitude range of the applied trigger signal. When the LEVEL/SLOPE control is outside the amplitude range, the trigger repetition rate is outside the frequency range selected by the COUPLING switch or the trigger signal is inadequate, there is no trace.

SINGLE SWP: Sweep initiated by the applied trigger signal at any point selected by the LEVEL/SLOPE control over the frequency range selected by the COUPLING switch. Triggered sweep can be obtained only over the amplitude range of applied trigger signal. After the first sweep is displayed, further sweeps cannot be presented until the RESET-READY push-button is pressed. When the LEVEL/SLOPE control is outside the amplitude range, the trigger repetition rate is outside the frequency range selected by the COUPLING switch, the trigger signal is inadequate or when the RESET-READY light is off, there is no trace.

RESET-READY: Push-button to reset the Sweep Generator for the next sweep in the single-sweep mode. The RESET-READY button remains lighted to indicate that the unit is ready to be triggered. After the unit is triggered and a sweep is completed, the RESET-READY light goes out until the button is pressed again.

COUPLING

Series of push-button switches to select the trigger coupling. Selected coupling is indicated by lighted button.

AC: Rejects DC and attenuates AC signals below about 30 hertz. Accepts signals between 30 hertz and 200 megahertz.

AC LF REJ: Rejects DC and attenuates signals below about 30 kilohertz. Accepts signals between 30 kilohertz and 200 megahertz.

AC HF REJ: Accepts signals between about 30 hertz and 50 kilohertz. Rejects DC and attenuates signals outside this frequency range.

DC: Accepts all trigger signals from DC to 200 megahertz.

SOURCE

Series of push-button switches to select the trigger source. Selected source is indicated by lighted button.

INT: Trigger signal obtained internally from a vertical unit.

LINE: Trigger signal obtained internally from a sample of the line voltage applied to this instrument.

EXT: Trigger signal obtained from an external signal applied to the EXT TRIG IN connector.

EXT ÷ 10: Trigger signal obtained from an external signal applied to the EXT TRIG IN connector as in the EXT position. In this

position the external signal is attenuated 10 times before it is applied to the trigger circuit.

EXT TRIG IN Input connector for external trigger signal.

Sweep Controls

POSITION Controls horizontal position of display.

FINE Provides more precise control of horizontal positions.

TIME/DIV OR DLY TIME Selects the basic sweep rate of the output sawtooth and selects basic delay time (to be multiplied by the DELAY TIME MULT dial setting). The VARIABLE control must be in calibrated position and MAGNIFIED switch set to X1 for indicated sweep rate.

VARIABLE Two-position switch actuated by the VARIABLE knob to select calibrated or uncalibrated sweep rates. At the in position, the VARIABLE control is inoperative and the sweep rate is calibrated. When pressed and released, the knob moves out to activate the VARIABLE control for uncalibrated sweep rates. The sweep rate in each TIME/DIV switch position can be reduced to at least the sweep rate of the next adjacent position, to provide continuously variable sweep rates from 2 nanoseconds/division (X10-MAGNIFIER on) to about 12.5 seconds/division, with MAGNIFIER at X1.

MAGNIFIER Push-button switches to select the horizontal magnification. The Selected magnification is indicated by a lighted button.

X1: Magnified sweep at the basic sweep rate indicated by TIME/DIV switch.

X10: Magnified sweep at a sweep rate 10 times faster than the basic sweep rate indicated by the TIME/DIV switch. The portion of the normal sweep within the center division of the graticule is the portion shown in magnified form.

SWP CAL Screwdriver adjustment to set amplitude of the output sawtooth.

Delay Controls

B DELAY MODE (A INTEN DURING B) Series of push-button switches to select the delay logic to the companion delayed-sweep unit (B). Selected delay mode is indicated by a lighted button.

INDEPENDENT: The 7B71 and the companion delayed-sweep unit (B) operate independently as normal time-base units.

B STARTS AFTER DELAY: The companion delayed-sweep unit (B) produces a sweep immediately following the delay time selected by the TIME/DIV OR DLY TIME switch and the DELAY TIME MULT dial.

B TRIGGERABLE AFTER DELAY: The companion delayed-sweep unit (B) produces a sweep after the first trigger pulse is received following the delay time selected by the TIME/DIV OR DLY TIME switch and the DELAY TIME MULT DIAL.

DELAY TIME MULT Provides variable delay for the delay pulse to the companion delayed-sweep unit (B) from 0 to 10 times the basic delay time selected by the TIME/DIV OR DELAY TIME switch.

TEST SETUP CHART

General

Fig. 2-3 shows the front panel of the 7B71. This chart can be reproduced and used as a test-setup record for special measurements, applications or procedures, or it may be used as a training aid for familiarization with this instrument.

GENERAL OPERATING INFORMATION

Sweep Calibration Check

Whenever the 7B71 is inserted into a plug-in compartment other than the one in which it was calibrated, the sweep calibration should be checked and readjusted if

7B71 TEST SET-UP CHART

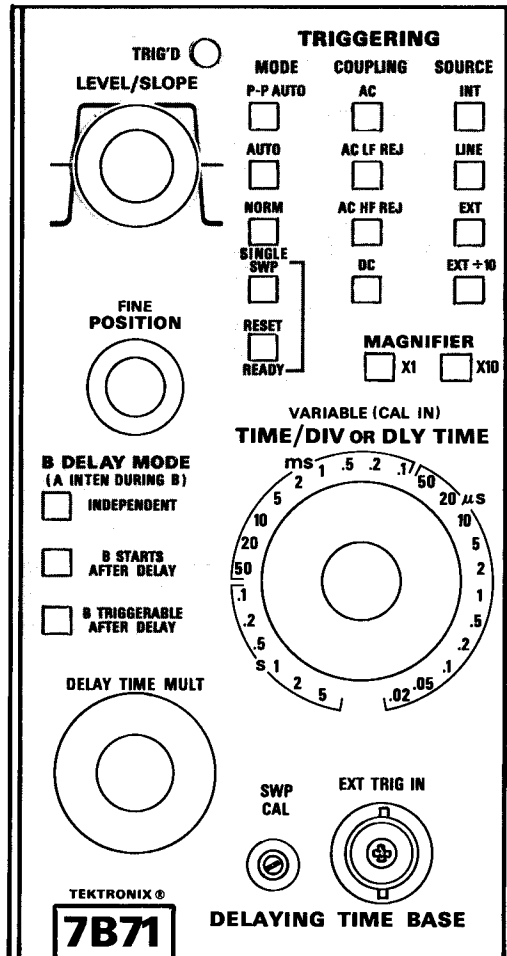

NOTES:

Fig. 2-3. 7B71 Test Setup Chart.

Operating Instructions—7B71

necessary. Allow five minutes warmup before performing this procedure.

1. Connect a one-kilohertz calibrator signal from the Indicator Oscilloscope Calibrator to the Vertical unit input connector.
2. Set the TIME/DIV switch to 1 ms and press the top TRIGGERING and B DELAY MODE pushbuttons.
3. Set the Vertical unit to display at least two divisions of the signal vertically.
4. Check the CRT display for one complete cycle per division.
5. If necessary, adjust the SWP CAL adjustment for one complete cycle per division.

Simplified Operating Instructions

The following information is provided to aid in quickly obtaining the correct settings for the 7B71 to present a display. The operator should be familiar with the complete function and operation of the unit as described in this section before using this procedure.

Normal Sweep. The following procedure will provide a stable display for most normal-sweep applications.

1. Select the TRIGGERING MODE, COUPLING and SOURCE which fit the requirements of the signal to be displayed.
2. Turn the LEVEL/SLOPE control to the desired slope.
3. If the green TRIG'D light is not on, adjust the LEVEL/SLOPE control throughout the range of the selected slope until the TRIG'D light comes on. If the light does not come on at any setting of the LEVEL/SLOPE control, the trigger signal is inadequate or the COUPLING and SOURCE switches are set incorrectly.
4. Set the TIME/DIV switch and POSITION control for a display which remains on the display area horizontally (VARIABLE control should be in CAL position for calibrated sweep rates).
5. If the display does not start at the correct point on the waveform, readjust the LEVEL/SLOPE control for the desired triggering.

Magnified Sweep. A magnified-sweep display can be obtained as follows after a normal-sweep display is obtained as given in steps 1-5 above.

1. Adjust the POSITION control to move the area to be magnified within the center division of the CRT.
2. If necessary, change the TIME/DIV switch setting so the complete area to be magnified is within the center division.
3. Press the X10-MAGNIFIER push-button.
4. Use the fine range of the POSITION control to establish precise positioning of the magnified display.

Delayed Sweep. The following procedure can be used to obtain a delayed-sweep display when the 7B71 is used in an oscilloscope that has dual time base capabilities and when used with a companion delayed-sweep unit (B). Obtain a display as given in steps 1-5 under Normal Sweep. Then proceed as follows:

1. Press the B STARTS AFTER DELAY push-button.
2. Set the indicator oscilloscope horizontal mode to display the A time base (7B71).
3. Set the time/division switch of the companion delayed-sweep unit (B) so the intensified zone on the display is the desired length (intensified zone will be displayed in delayed form). If the intensified zone is not visible, adjust the indicator intensity controls.
4. Adjust the DELAY TIME MULT dial to position the intensified zone to the portion of the display to be delayed.
5. Set the indicator oscilloscope horizontal mode to display the B time base (delayed sweep unit).
6. If a delayed sweep with less jitter is desired, press the 7B71 B TRIGGERABLE AFTER DELAY push-button. The triggering controls of the companion delayed-sweep unit (B) must be set to obtain a stable display. See the instruction manual for that unit for further information.

Pushbutton Switch Logic

The TRIGGERING MODE, COUPLING and SOURCE switches and the B DELAY MODE switch are arranged in a

sequence which places the most often-used position at the top of each series of pushbuttons. With this arrangement, a stable display can usually be obtained by pressing the top push-buttons; P-P AUTO, AC, INT and INDEPENDENT. When an adequate trigger signal is applied, the unit is triggered as indicated by the illuminated TRIG'D light at any setting of the LEVEL/SLOPE control. If the TRIG'D light is not on, either the trigger signal applied to this unit from the vertical unit is inadequate or it is below the lower frequency limit of the AC COUPLING switch position. If the desired display is not obtained with the pushbuttons pushed in, other selections must be made. Refer to the following discussions or the instruction manuals for the associated indicator oscilloscope and vertical unit for more information.

Triggered Light

The TRIG'D light provides a convenient indication of the condition of the triggering circuits. If the TRIGGERING controls are correctly set and an adequate trigger signal is applied, the TRIG'D light is on. Under certain conditions, the TRIG'D light may be off, indicating that the sweep is not triggered. The cause might be a misadjusted LEVEL/SLOPE control, incorrectly set COUPLING or SOURCE switches, low trigger signal amplitude, or a trigger signal repetition rate outside the acceptable frequency range. This feature can be used as a general indication of correct triggering. It is particularly useful when setting up the trigger circuits when a trigger signal is available without a display on the CRT. It also indicates that this unit is correctly triggered when operating as a delaying-sweep unit (A).

Trigger Mode

The pushbuttons located under the MODE title (see Fig. 2-4) select the mode in which the sweep is triggered. The selected mode is indicated by a lighted pushbutton.

~~The P-P AUTO pushbutton is illuminated when the trigger signal amplitude is above the peak-to-peak amplitude of the signal. The LEVEL/SLOPE control can be set so the displayed waveform starts at any point within this range on either slope. In the P-P AUTO mode, the trigger circuit automatically compensates for changes in trigger signal amplitude for signals above the minimum amplitude requirement. Therefore, if the LEVEL/SLOPE control is set so the displayed waveform starts at a certain percentage-point on the leading edge of a low-amplitude signal, it triggers at the same percentage-point on the leading edge of a high-amplitude signal if the LEVEL/SLOPE control is not changed. This operation is illustrated in Fig. 2-5.~~

good large or for signal

When the trigger repetition rate is below about 200 hertz (or outside the frequency range selected by the COUPLING switch), or when the trigger signal is inadequate, the sweep free runs at the sweep rate indicated by the TIME/DIV switch to produce a reference trace (TRIG'D light off). When an adequate trigger signal is again applied, the free-running condition ends and a triggered display is presented.

The ~~P-P AUTO~~ mode is particularly useful when observing a series of waveforms, since it is not necessary to reset the LEVEL/SLOPE control for each observation. Also, because of the ease of obtaining a triggered display in this mode, the P-P AUTO trigger mode can be used for most applications and the remaining modes used only for special applications or when stable triggering is not obtainable in this mode.

Automatic Stability

When the AUTO push-button is illuminated, a triggered display is presented with the correct setting of the LEVEL/SLOPE control (see Trigger Level discussion) whenever an adequate trigger signal is applied. The range of the LEVEL/SLOPE control in this mode is ± 8 vertical divisions. The TRIG'D light indicates when the display is triggered.

Bright Line Automatic

When the trigger repetition rate is below about 30 hertz (or outside the frequency range selected by the COUPLING switch) or ~~when the trigger signal is inadequate~~

~~the sweep free runs at the sweep rate indicated by the TIME/DIV switch to produce a reference trace (TRIG'D light off).~~ When an adequate trigger signal is again applied, the free-running condition ends and a triggered display is presented.

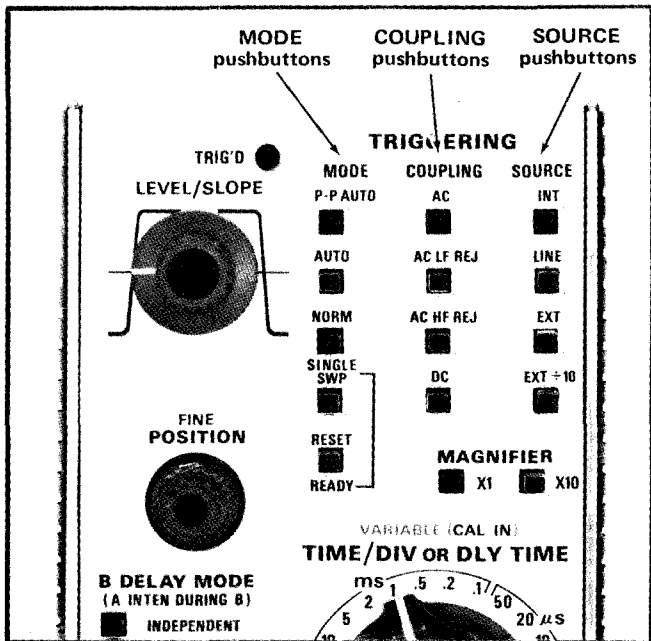

Fig. 2-4. View of front panel showing push-buttons associated with the MODE, COUPLING and SOURCE switches.

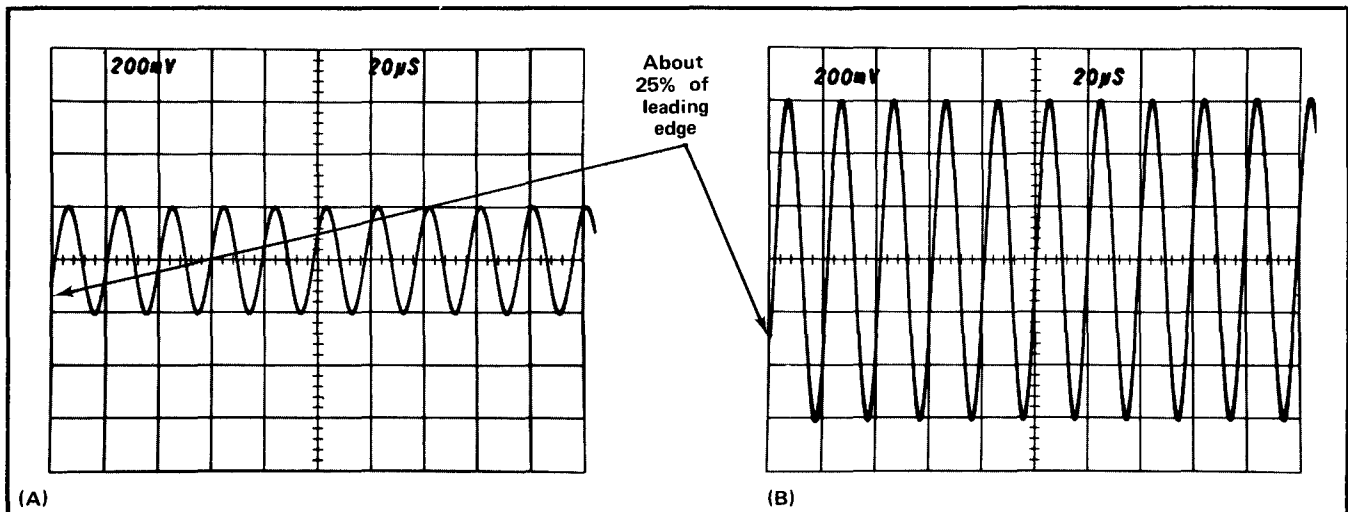

Fig. 2-5. LEVEL/SLOPE control operation for (P-P) AUTO mode triggering. (A) LEVEL/SLOPE control set so displayed waveform starts at about 25% point of a two-division waveform. (B) displayed waveform still triggered at about 25% of leading edge, when signal amplitude increases to produce a six-division display (LEVEL/SLOPE control at same setting for both waveforms).

When the LEVEL/SLOPE control is at a setting outside the amplitude range of the trigger signal, the sweep also free runs at the sweep rate indicated by the TIME/DIV switch. This type of free-running display can be useful when it is desired to measure only the maximum peak-to-peak amplitude of a signal without observing the waveshape (such as in bandwidth measurements).

NORM When the NORM push-button is pressed, a triggered display is produced with the same setting of the LEVEL/SLOPE control whenever an adequate trigger signal is applied. The range of the LEVEL/SLOPE control in this mode is ± 8 vertical divisions. The TRIG'D light indicates when the display is triggered.

The NORM trigger mode must be used to produce triggered displays with trigger repetition rates below about 30 hertz. When the LEVEL/SLOPE control is at a setting outside the amplitude range of the trigger signal, when the trigger repetition rate is outside the frequency range selected by the COUPLING switch or ~~the trigger signal is inadequate, there is no trace (TRIG'D light off).~~

SINGLE SWP. When the signal to be displayed is not repetitive or varies in amplitude, waveshape or repetition rate, a conventional repetitive type display may produce an unstable presentation. A stable display can often be obtained under these circumstances by using the single-sweep feature of this unit. The SINGLE SWP MODE is also useful to photograph non-repetitive or unstable displays.

To obtain a single-sweep display of a repetitive signal, first obtain the best possible display in the NORM MODE.

Then without changing the other TRIGGERING controls, press the SINGLE SWP pushbutton. When ready to view the single-sweep display, press the RESET-READY pushbutton. A single trace is presented each time the RESET-READY pushbutton is pressed (as long as the repetitive signal remains connected to the system and TRIGGERING controls are correctly set) and further sweeps cannot be presented until the RESET-READY pushbutton is pressed again. If the displayed signal is a complex waveform composed of pulses of varying amplitude, successive single-sweep displays may not start at the same point of the waveform. To avoid confusion due to the CRT persistence, allow the display to decay before pressing the RESET-READY pushbutton again. At fast sweep rates, it may be difficult to view the single-sweep display. The apparent trace intensity can be increased by reducing the ambient light level or using a viewing hood as recommended in the indicator instruction manual.

Non-repetitive, random signals can be displayed in the single-sweep mode by first obtaining the best possible display in the NORM MODE with a signal which is about the same amplitude and frequency as the random signal. Then without changing the other TRIGGERING controls, press the SINGLE SWP pushbutton. When ready for the random signal, press the RESET-READY pushbutton. The RESET-READY pushbutton remains lighted to indicate that the unit has been reset and is ready to produce a sweep. The light goes out after the random signal triggers the unit. To prepare the unit for another single-sweep display, press the RESET-READY pushbutton again.

When using the single-sweep mode to photograph waveforms, the graticule must be photographed separately in the normal manner to prevent over-exposing the film. Be sure

the camera system is well protected against stray light, or operate the system in a darkened room. For repetitive waveforms, press the RESET-READY pushbutton only once for each waveform unless the signal is completely symmetrical. Otherwise, multiple waveforms may appear on the film. For random signals, the camera lens can be left open until the random signal triggers the unit (RESET-READY pushbutton lighted). Further information on photographic techniques is given in the camera instruction manual.

The pushbuttons located below the COUPLING title (see Fig. 2-4) select the method in which the trigger signal is connected to the trigger circuits. The selected coupling is indicated by a lighted pushbutton. Each position permits selection or rejection of the frequency components of the trigger signal which trigger the sweep. Fig. 2-6 graphically illustrates the band of frequencies covered by each position of the COUPLING switch.

AC. In the AC position of the COUPLING switch, the DC component of the trigger signal is blocked. Signals with low-frequency components below about 30 hertz are attenuated. In general, AC COUPLING can be used for most applications. However, if the signal contains unwanted frequency components or if the sweep is to be triggered at a

low repetition rate or DC level, one of the remaining COUPLING switch positions will provide a better display.

The triggering point in the AC position depends upon the average voltage level of the trigger signal. If the trigger signal occurs randomly, the average voltage level will vary, causing the triggering point to vary also. This shift of the triggering point may be enough so it is impossible to maintain a stable display. In such cases, use DC coupling.

AC LF REJ. In the AC LF REJ position, DC is rejected and low-frequency trigger signals below about 30 kilohertz are attenuated. Therefore, the sweep is triggered only by the higher-frequency components of the trigger signal. This position is particularly useful for providing stable triggering if the trigger signal contains line-frequency components. Also, the AC LF REJ position provides the best alternate-mode vertical displays at fast sweep rates when comparing two or more unrelated signals (with dual-trace vertical or slaved triggering operation for dual-vertical unit operation).

AC HF REJ. The AC HF REJ position passes all low-frequency signals between about 30 hertz and 50 kilohertz. DC is rejected and signals outside the above range are attenuated. When triggering from complex waveforms, this position is useful for providing stable display of the low-frequency components.

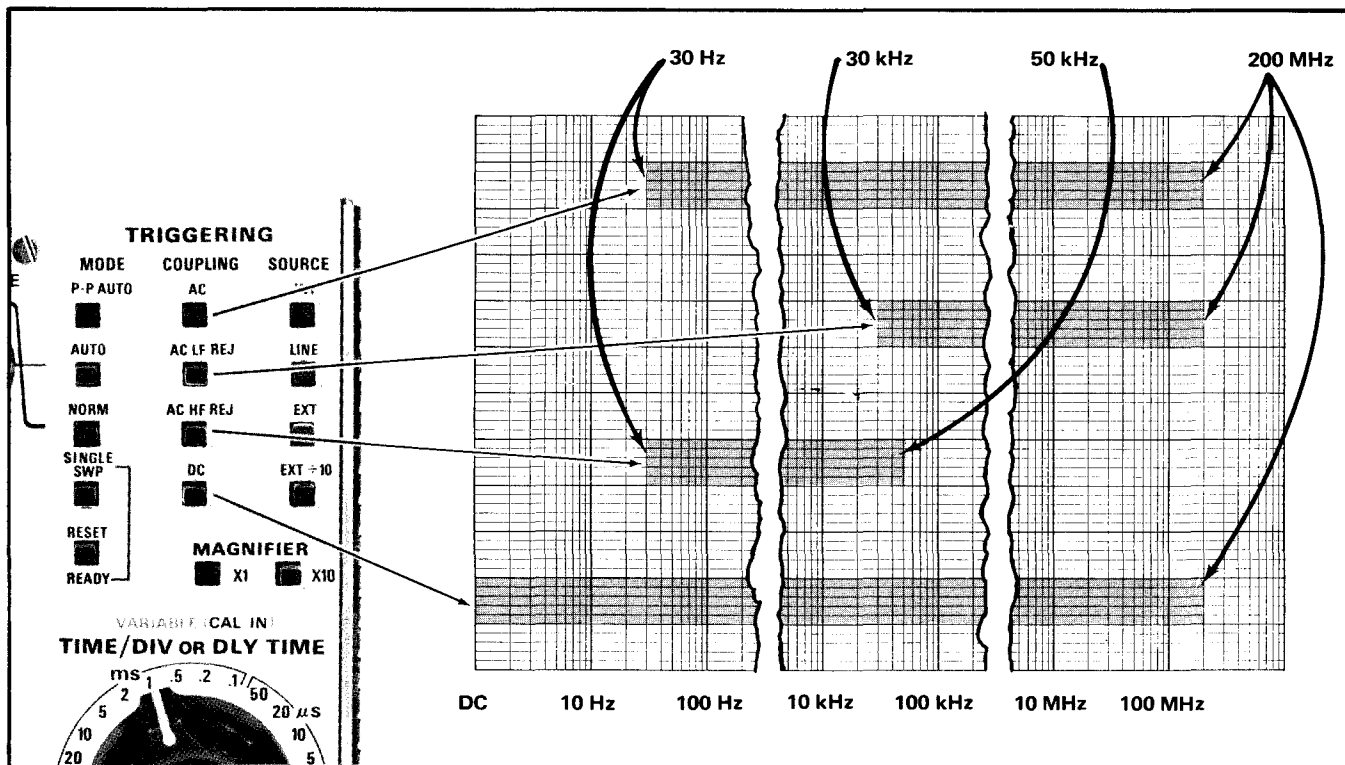

Fig. 2-6. Frequency range of each COUPLING switch position.

DC. DC COUPLING can be used to provide stable triggering with low-frequency signals which would be attenuated in the other modes, or with low-repetition rate signals. It can also be used to trigger the sweep when the trigger signal reaches a DC level selected by the setting of the LEVEL/SLOPE control. When using internal triggering, the setting of the vertical unit position controls affects the DC triggering point.

Trigger Source

The pushbuttons located below the SOURCE title (see Fig. 2-4) select the source of the trigger signal which is connected to the trigger circuits. The selected source is indicated by a lighted pushbutton.

INT. In the INT position of the SOURCE switch, the trigger signal is derived from the associated vertical unit. Further selection of the internal trigger signal may be provided by the associated vertical unit or indicator oscilloscope; see the instruction manuals for these instruments for information. For most applications, the INT-SOURCE position can be used. However, some applications require special triggering which cannot be obtained in the INT-SOURCE position. In such cases LINE- or EXT-SOURCE must be used.

LINE. The LINE position of the SOURCE switch connects a sample of the power-line voltage, to which the indicator oscilloscope is connected, to the trigger circuit. Line triggering is useful when the input signal is time-related (multiple or sub-multiple) to the line frequency. It is also useful for providing a stable display of a line-frequency component in a complex waveform.

EXT. An external signal connected to the EXT TRIG IN connector can be used to trigger the sweep in the EXT-SOURCE position. The external signal must be time-related to the displayed waveform for a stable display. An external trigger signal can be used to provide a triggered display when the internal signal is too low in amplitude for correct triggering or contains signal components on which it is not desired to trigger. It is also useful when signal tracing in amplifiers, phase-shift networks, wave-shaping circuits, etc. The signal from a single point in the circuit under test can be connected to the EXT TRIG IN connector through a probe or cable. The sweep is then triggered by the same signal at all times and allows amplitude, time relationship or waveshape changes of signals at various points in the circuit to be examined without resetting the TRIGGERING controls.

EXT ÷ 10. Operation in the EXT ÷ 10 position is the same as described for EXT except that the external signal is attenuated 10 times. Attenuation of high-amplitude exter-

nal trigger signals is desirable to broaden the range of the LEVEL/SLOPE control.

Trigger Slope

The LEVEL/SLOPE control determines whether the trigger circuit responds on the positive-going or negative-going portion of the trigger signal. When the indicator line on the outer ring of the LEVEL/SLOPE control is to the left of center, the display starts on the positive-going portion of the waveform (notice positive-going waveform to left of control). To the right of center, the display starts on the negative-going portion of the waveform (notice negative-going waveform). The effect of the LEVEL/SLOPE control on the displayed waveform is shown in Fig. 2-7. When several cycles of a signal appear in the display, the selection of the trigger slope is often unimportant. However, if only a certain portion of a cycle is to be displayed, correct setting of the LEVEL/SLOPE control is important to provide a display which starts on the desired slope of the input signal.

Trigger Level

The LEVEL/SLOPE control determines the voltage level on the trigger signal at which the display is triggered, as well as selecting the trigger slope. The center knob of the LEVEL/SLOPE control provides about a 3:1 reduction in relation to the outer indicator ring, to allow precise level selection. This control can also be turned throughout the complete 360° rotation to allow continuous triggering over the selected slope. This is particularly useful in the P-P AUTO MODE. When the LEVEL/SLOPE control is set to the "O" on either the positive-going or negative-going waveform, the sweep is triggered near the zero-volt level of the trigger signal. As the LEVEL/SLOPE control is rotated away from the "O", the displayed waveform starts at a point corresponding to the position of the indicator line on the associated slope waveform (within amplitude range of trigger signal except in P-P AUTO MODE which provides triggered display throughout entire slope). For example if the LEVEL/SLOPE control is turned clockwise from the "O" on the positive-going slope, the displayed waveform starts at a more positive level. Fig. 2-7 illustrates the operation of the LEVEL/SLOPE control at different levels and slopes of a displayed waveform.

Before setting the triggering level, select the TRIGGERING SLOPE, MODE, COUPLING and SOURCE. Then adjust the LEVEL/SLOPE control so the displayed waveform starts at the desired point. The triggering slope can be changed at any time by rotating the LEVEL/SLOPE control to the corresponding point on the other slope waveform.

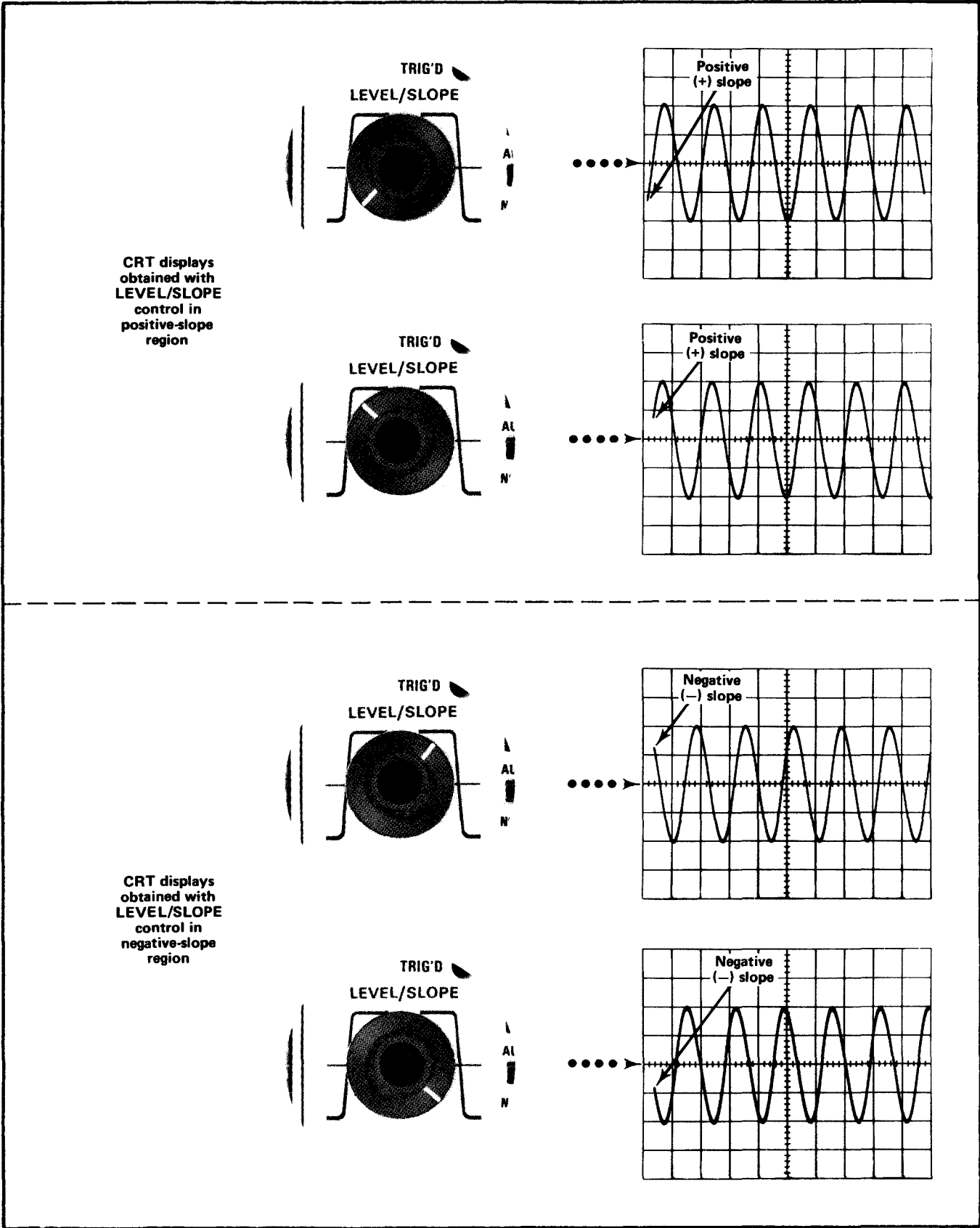

FIG. 2-7. Effect of LEVEL/SLOPE control on CRT display (AUTO P-P MOD).

Horizontal Sweep Rate

The TIME/DIV switch provides 26 calibrated sweep rates ranging from 0.02 microsecond/division to five seconds/division. The VARIABLE TIME/DIV control must be in the calibrated position and the MAGNIFIER at X1 for the indicated sweep rate. The VARIABLE TIME/DIV control incorporates a two-position switch to determine if the sweep rate is calibrated or uncalibrated. When the VARIABLE knob is in the inward position, the VARIABLE TIME/DIV control is inoperative and the sweep rate is calibrated. When pressed and released, the VARIABLE knob moves outward to activate the VARIABLE TIME/DIV control for uncalibrated sweep rates. A calibrated sweep rate can be obtained at any position of the VARIABLE TIME/DIV control by pressing in the VARIABLE knob. This feature is useful when a specific uncalibrated sweep rate has been obtained and it is desired to switch between this uncalibrated sweep rate and a calibrated sweep rate. Switching from uncalibrated to calibrated operation or vice versa does not affect the setting of the VARIABLE TIME/DIV control. The VARIABLE TIME/DIV control allows the sweep rate in each TIME/DIV switch position to be reduced to at least the sweep rate of the next adjacent switch position. This provides an overall uncalibrated variable sweep rate range from 20 nanoseconds/division (from 2 nanoseconds/division with MAGNIFIER at X10) to about 12.5 seconds/division.

When making time measurements from the graticule, the area between the second-division and tenth-division vertical lines of the graticule provides the most linear time measurement (see Fig. 2-8). Therefore, the first and last division of the display area should not be used when making accurate time measurements. Position the start of the timing area to the second-division vertical line (second line from the left) and adjust the TIME/DIV switch so the end of the timing area falls between the second-division and tenth-division vertical lines.

Sweep Magnifier

Center division of the magnified display is the portion visible on the screen in magnified form (see Fig. 2-9). Equivalent length of the magnified sweep is more than 100 divisions; any 10-division portion can be viewed by adjusting the horizontal POSITION control to bring the desired portion onto the viewing area. The dual-range feature of the horizontal POSITION control is particularly useful when the MAGNIFIER is set to X10 (see Horizontal Position Control discussion which follows).

To use sweep magnification, first move the portion of the display which is to be expanded to the center of the graticule. Then press the X10-MAGNIFIER pushbutton; the X10 button lights to indicate that the horizontal sweep rate is magnified. Whenever the X10-MAGNIFIER push-

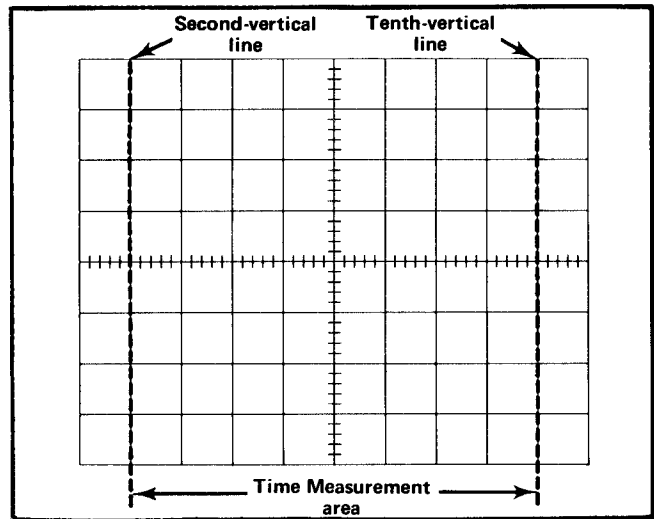

Fig. 2-8. Area of graticule used for accurate time measurements.

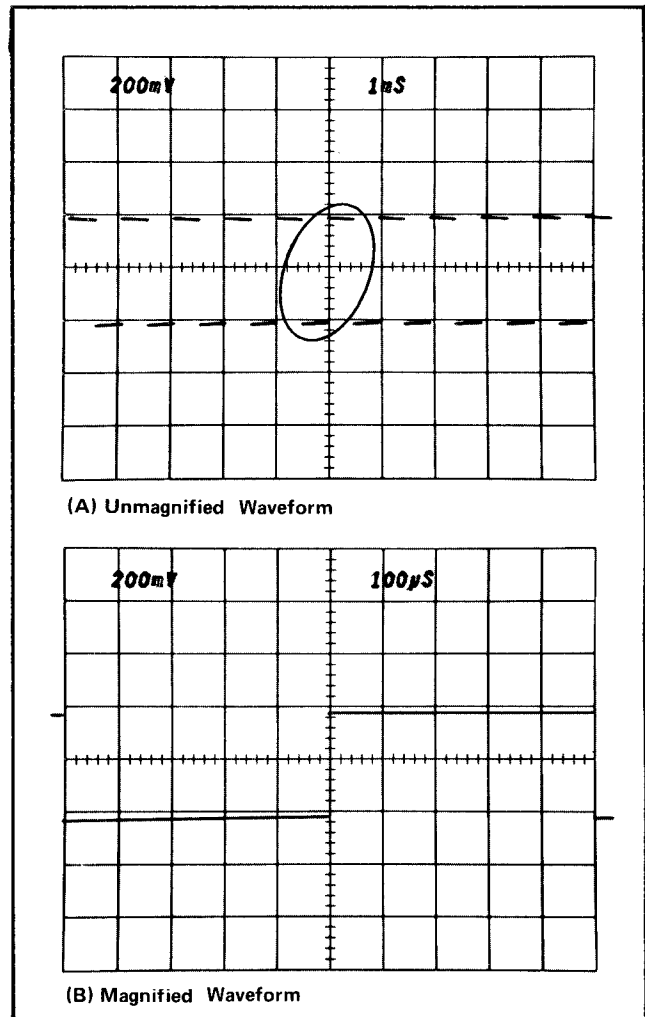

Fig. 2-9. Operation of sweep magnifier.

button is lighted, the equivalent magnified sweep rate can be determined by dividing the TIME/DIV switch setting by 10. For example, if the TIME/DIV switch is set to .05 μ s, the equivalent magnified sweep rate is 5 nanoseconds/division. The equivalent magnified sweep rate must be used for all time measurements when the X10-MAGNIFIER button is lighted. The equivalent magnified sweep rate is calibrated when the VARIABLE TIME/DIV control is in the calibrated position.

Horizontal Position Control

The 7B71 provides both fine and coarse adjustment of positioning. The coarse adjustment provides rapid horizontal positioning of the trace. Fine positioning is provided for more precise control of trace position.

APPLICATIONS

General

The following information describes the procedures and techniques for making basic measurements with a 7700-series Oscilloscope. These applications are not described in detail, since each application must be adapted to the requirements of the individual measurement. This instrument can also be used for many applications not described in this manual. Contact your local Tektronix Field Office or representative for assistance in making specific measurements. Also, the following books describe oscilloscope measurement techniques which can be adapted for use with this instrument:

Harley Carter, "An Introduction to the Cathode Ray Oscilloscope", Philips Technical Library, Cleaver-Hume Press Ltd., London, 1960.

J. Czech, "Oscilloscope Measuring Technique", Philips Technical Library, Springer-Verlag, New York, 1965.

Robert G. Middleton and L. Donald Payne, "Using the Oscilloscope in Industrial Electronics", Howard W. Sams & Co. Inc., The Bobbs-Merrill Company Inc., Indianapolis, 1961.

John F. Rider and Seymour D. Uslan, "Encyclopedia of Cathode-Ray Oscilloscopes and Their Uses", John F. Rider Publisher Inc., New York, 1959.

John F. Rider, "Obtaining and Interpreting Test Scope Traces", John F. Rider Publisher Inc., New York, 1959.

Rufus P. Turner, "Practical Oscilloscope Handbook", Volumes 1 and 2, John F. Rider Publisher Inc., New York, 1964.

Measurement Techniques

Sweep Rates. To establish an arbitrary horizontal sweep rate based upon a specific reference frequency, proceed as follows:

1. Connect the reference signal to the INPUT connector. Set the VOLTS/DIV switch for four or five divisions of vertical deflection.

2. Set the TIME/DIV switch and the VARIABLE TIME/DIV control so one cycle of the signal covers an exact number of horizontal divisions. Do not change the VARIABLE TIME/DIV control after obtaining the desired deflection. This display can be used as a reference for frequency comparison measurements.

3. To establish an arbitrary sweep rate so the repetition rate of an unknown signal can be measured accurately at any setting of the TIME/DIV switch, the repetition rate of the reference signal must be known. If it is not known, it can be measured before the VARIABLE TIME/DIV switch is set in step 2.

4. Divide the repetition rate of the reference signal (seconds) by the product of the horizontal deflection established in step 2 (divisions) and the setting of the TIME/DIV switch. This is the horizontal conversion factor:

$$\text{Horizontal Conversion Factor} = \frac{\text{reference signal repetition rate (seconds)}}{\text{horizontal deflection (divisions)} \times \text{TIME/DIV switch setting}}$$

5. To measure the repetition rate of an unknown signal, disconnect the reference signal and connect the unknown signal to the INPUT connector. Set the TIME/DIV switch to a setting that provides sufficient horizontal deflection to make an accurate measurement. Do not readjust the VARIABLE TIME/DIV control.

6. Measure the horizontal deflection in divisions and calculate the repetition rate of the unknown signal using the following formula:

$$\text{Repetition Rate} = \frac{\text{TIME/DIV switch setting}}{\text{horizontal conversion factor}} \times \text{horizontal deflection (divisions)}$$

NOTE

If the horizontal magnifier is used, be sure to use the magnified sweep rate in place of the TIME/DIV switch setting.

Example. Assume a reference signal frequency of 455 hertz (repetition rate 2.19 milliseconds), a TIME/DIV switch setting of .2 ms, and the VARIABLE TIME/DIV control adjusted to provide a horizontal deflection of eight divisions. Substituting these values in the horizontal conversion factor formula (step 4):

$$\text{Horizontal Conversion Factor} = \frac{2.19 \text{ milliseconds}}{.2 \times 8} = 1.37$$

Then, with a TIME/DIV switch setting of 50 μs, the repetition rate of an unknown signal which completes one cycle in seven horizontal divisions can be determined by using the repetition rate formula (step 6):

$$\text{Repetition Rate} = 50 \mu\text{s} \times 1.37 \times 7 = 480 \mu\text{s}$$

This answer can be converted to frequency by taking the reciprocal of the repetition rate (see application on Determining Frequency Measurements).

Time-Duration Measurements

To measure time between two points on a waveform, use the following procedure:

1. Connect the signal to either Vertical plug-in.
2. Set the MODE switch to display the plug-in used.
3. Set the VOLTS/DIV switch to display about four divisions of the waveform.
4. Set the A Triggering controls to obtain a stable display.
5. Set the TIME/DIV switch to the fastest sweep rate that displays less than eight divisions between the time measurement points (see Fig. 2-8). (See the topic entitled Horizontal Sweep Rate in this section concerning non-linearity of first and last divisions of a display.)

6. Adjust the vertical POSITION control to move the points between which the time measurement is made to the center horizontal reference line.

7. Adjust the horizontal POSITION control to position the time-measurement points within the center eight divisions of the graticule.

8. Measure the horizontal distance between the time measurement points. Be sure the A VARIABLE control is set to CAL.

9. Multiply the distance measured in step 8 by the setting of the TIME/DIV switch. If sweep magnification is used, divide this answer by 10.

Example. Assume that the distance between the time measurement points is five divisions (see Fig. 2-10), and the TIME/DIV switch is set to .1 ms with the magnifier at X1. Using the formula:

$$\text{Time Duration} = \frac{\text{horizontal distance (divisions)} \times \text{TIME/DIV setting}}{\text{magnification}}$$

Substituting the given values:

$$\text{Time Duration} = \frac{5 \times 0.1 \text{ ms}}{1}$$

The time duration is 0.5 milliseconds.

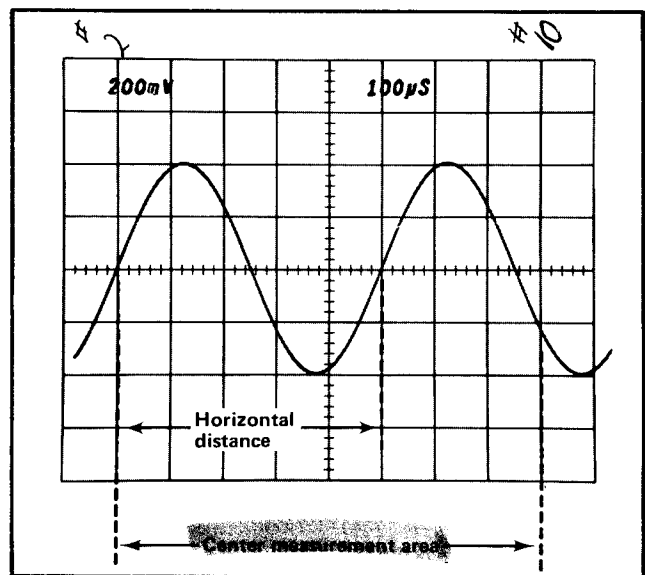

Fig. 2-10. Measuring the time duration between points on a waveform.

Determining Frequency

The time measurement technique can also be used to determine the frequency of a signal. The frequency of a periodically recurrent signal is the reciprocal of the time duration (period) of one complete cycle.

Use the following procedure:

1. Measure the time duration of one complete cycle of the waveform as described in the previous application.
2. Take the reciprocal of the time duration to determine the frequency.

Example. The frequency of the signal shown in Fig. 2-10 which has a time duration of 0.5 milliseconds is:

$$\text{Frequency} = \frac{1}{\text{time duration}} = \frac{1}{0.5 \text{ ms}} = 2 \text{ kilohertz}$$

Risetime Measurements

Risetime measurements employ basically the same techniques as time-duration measurements. The main difference is the points between which the measurement is made. The following procedure gives the basic method of measuring risetime between the 10% and 90% points of the waveform. Falltime can be measured in the same manner on the trailing edge of the waveform.

1. Connect the signal to either Vertical plug-in.
2. Set the MODE switch to display the plug-in used.
3. Set the VOLTS/DIV switch and the VARIABLE control to produce a signal an exact number of divisions in amplitude.
4. Center the display about the center horizontal line with the vertical POSITION control.
5. Set the A Triggering controls to obtain a stable display.
6. Set the TIME/DIV switch to the fastest sweep rate that displays less than eight divisions between the 10% and 90% points on the waveform.

7. Determine the 10% and 90% points on the rising portion of the waveform. The figures given in Table 2-1 are for the points 10% up from the start of the rising portion and 10% from the top of the rising portion (90% point).

TABLE 2-1
Risetime Measurements

Vertical display (divisions)	10% and 90% points	Divisions vertically between 10% and 90% points
4	0.4 and 3.6 divisions	3.2
5	0.5 and 4.5 divisions	4.0
6	0.6 and 5.4 divisions	4.8

8. Adjust the horizontal POSITION control to move the 10% point of the waveform to the second vertical line of the graticule. For example, with a five-division display as shown in Fig. 2-11, the 10% point is 0.5 division up from the start of the rising portion.

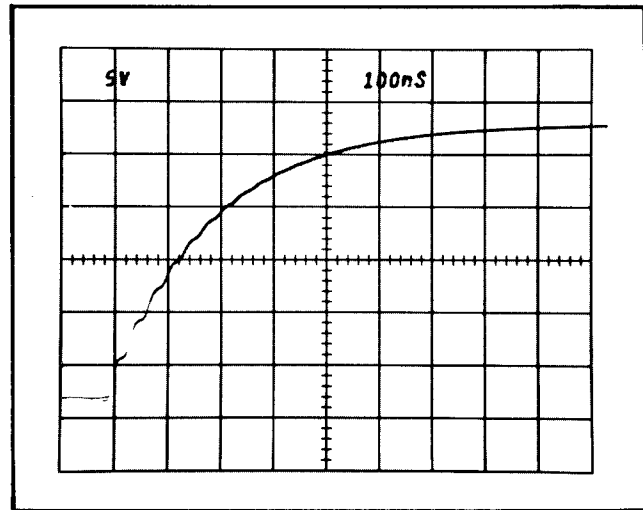

Fig. 2-11. Measuring risetime.

9. Measure the horizontal distance between the 10% and 90% points. Be sure the A VARIABLE control is set to CAL.
10. Multiply the distance measured in step 9 by the setting of the TIME/DIV switch. If sweep magnification is used, divide this answer by 10.

Example. Assume that the horizontal distance between the 10% and 90% points is four divisions (see Fig. 2-11) and

Operating Instructions—7B71

the TIME/DIV switch is set to 1 μs with the MAG switch set to X10. Applying the time duration formula to risetime:

$$\text{Time Duration (Risetime)} = \frac{\text{horizontal distance (divisions)} \times \text{TIME/DIV setting}}{\text{magnification}}$$

Substituting the given values:

$$\text{Risetime} = \frac{4 \times 1 \mu\text{s}}{10}$$

The risetime is 0.4 microsecond.

Delayed Sweep Time Measurements

The delayed sweep mode can be used to make accurate time measurements. The following measurement determines the time difference between two pulses displayed on the same trace. This application may also be used to measure time difference from two different sources (dual-trace) or to measure time duration of a single pulse. See Section one for measurement accuracy.

1. Connect the signal to either vertical plug-in. Set the Indicator Oscilloscope vertical MODE selector to display the plug-in being used. Set the horizontal MODE selector to CHOP or ALT (see Oscilloscope Manual discussion on horizontal mode switching) to display both Time-Base sweeps.

2. Set the VOLTS/DIV selector to produce a display about three divisions in amplitude (see Fig. 2-12).

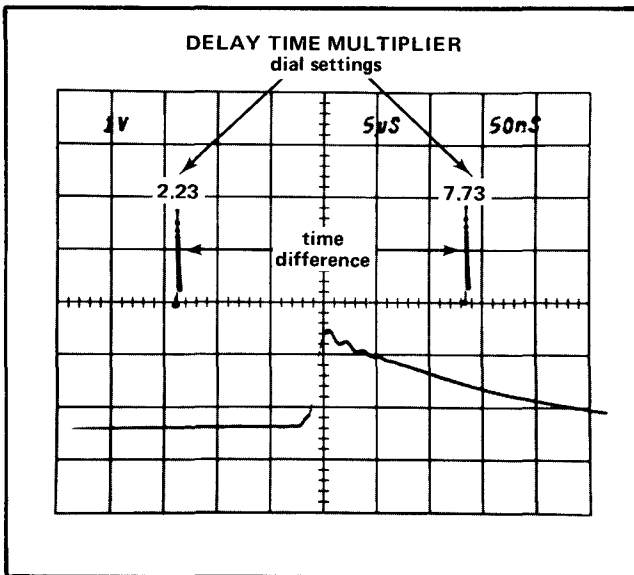

Fig. 2-12. Measuring time difference using delayed sweep.

3. Set the A TIME/DIV to a sweep rate which displays about six divisions between pulses. Adjust the A Triggering controls for a stable display.

4. Set the A Time-Base B DELAY MODE selector to B STARTS AFTER DELAY.

5. Set the B Time/div to a setting 1/100 of the A TIME/DIV sweep rate. This produces an intensified portion about 0.1 division in length.

NOTE

Do not change the A LEVEL control setting or the horizontal POSITION control setting in the following steps, as the measurement accuracy will be affected.

6. Turn the DELAY-TIME MULTIPLIER dial to move the intensified portion of the A sweep to the first pulse.

7. Adjust the DELAY-TIME MULTIPLIER dial to move the pulse (or rising portion) of the B sweep to the center vertical line. Note the setting of the DELAY-TIME MULTIPLIER dial.

8. Turn the DELAY-TIME MULTIPLIER dial clockwise until the second pulse is positioned to this same point (if several pulses are displayed, observe the intensified portion of the A sweep to locate the correct pulse). Again note the dial setting.

9. Subtract the first dial setting from the second and multiply by the delay time shown by the A TIME/DIV selector. This is the time interval between the pulses.

Example: Assume the first dial setting is 2.23 and the second dial setting is 7.73 with the TIME/DIV set to 5 μs (see Fig. 2-13).

Using the formula:

$$\text{Time Difference (delayed sweep)} =$$

$$\text{second dial setting} - \text{first dial setting} \times \text{delay time (A TIME/DIV setting)}$$

Substituting the given values:

$$\text{Time Difference} = (7.73 - 2.23) \times 5 \mu\text{s}$$

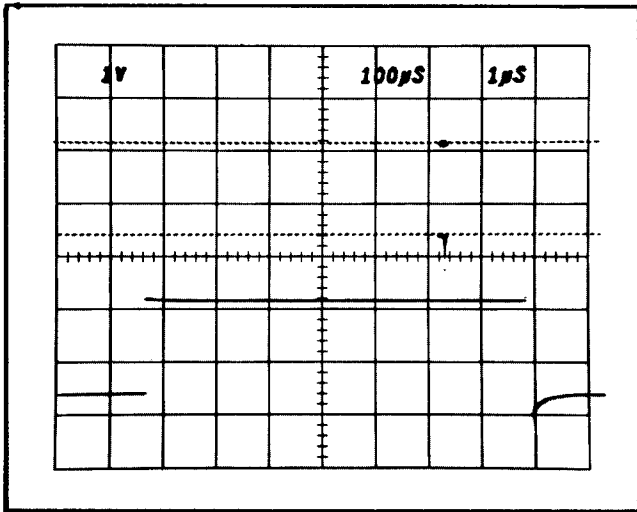

Fig. 2-13. Using delayed sweep for sweep magnification.

The time difference is 27.5 microseconds.

Delayed Sweep Magnification

The delayed sweep feature of the 7B71 can be used to provide higher apparent magnification than is provided by the MAG switch. The sweep rate of the DELAYED SWEEP (B sweep) is not actually increased; the apparent magnification is the result of delaying the B sweep an amount of time selected by the A TIME/DIV switch and the DELAY-TIME MULTIPLIER dial before the display is presented at the sweep rate selected by the B TIME/DIV switch. The following method uses the B STARTS AFTER DELAY position to allow the delayed portion to be positioned with the DELAY-TIME MULTIPLIER dial. If there is too much jitter in the delayed display, use the Triggered Delayed Sweep Magnification procedure.

1. Connect the signal to either vertical plug-in. Set the Indicator Oscilloscope vertical MODE selector to display the plug-in used and the horizontal MODE to CHOP or ALT to display both Time-Base sweeps.

2. Set the VOLTS/DIV selector to produce a display about three divisions in amplitude.

3. Set the A Time-Base B DELAY MODE selector to B STARTS AFTER DELAY. Adjust the A Triggering controls for a stable display.

4. Set the A TIME/DIV to a sweep rate which displays the complete waveform.

5. Position the start of the intensified portion with the DELAY-TIME MULTIPLIER dial to the part of the display to be magnified.

6. Set the B TIME/DIV to a setting which intensifies the full portion to be magnified. The start of the intensified trace remains as positioned above.

7. Time measurements can be made from the display in the conventional manner. Sweep rate is determined by the setting of the B TIME/DIV selector.

Example: The apparent magnification of the display shown in Fig. 2-13 with an A TIME/DIV setting of .1 ms and a B TIME/DIV setting of 1 µs is:

$$\text{Apparent Magnification (Delayed Sweep)} = \frac{\text{A TIME/DIV setting}}{\text{B TIME/DIV setting}}$$

Substituting the given values:

$$\text{Apparent Magnification} = \frac{1 \times 10^{-4}}{1 \times 10^{-6}} = 100$$

The apparent magnification is 100 times.

Triggered Delayed Sweep Magnification. The delayed sweep magnification method just described may produce too much jitter at high apparent magnification ranges. The B TRIGGERABLE AFTER DELAY position of the B DELAY MODE selector provides a more stable display, since the delayed display is triggered at the same point each time.

1. Set up the display as given in steps 1 through 6 above.

2. Set the B DELAY MODE selector to B TRIGGERABLE AFTER DELAY.

3. Adjust the B LEVEL control so the intensified portion on the trace is stable.

4. Inability to intensify the desired portion indicates that the B Triggering controls are incorrectly set or the

signal does not meet the triggering requirements. If the condition cannot be remedied with the B Triggering controls or by increasing the display amplitude (lower VOLTS/DIV setting), trigger the B sweep externally.

5. Measurement and magnification are as described above.

Displaying Complex Signals Using Delayed Sweep

Complex signals often consist of a number of individual events of differing amplitudes. Since the trigger circuits are sensitive to changes in signal amplitude, a stable display can normally be obtained only when the sweep is triggered by the event(s) having the greatest amplitude. However, this may not produce the desired display of a lower-amplitude portion which follows the triggering event. The delayed sweep feature provides a means of delaying the start of the B sweep by a selected amount following the event which triggers the A Sweep Generator. Then, the part of the waveform which contains the information of interest can be displayed.

Use the following procedure:

1. Set up the display as given in Delayed Sweep Magnification Steps 1 through 6.
2. Time measurements can be made from the display in the conventional manner. Sweep rate is determined by the setting of the B TIME/DIV selector.

Example. Fig. 2-14 shows a complex waveform as displayed on the CRT. the circled portion of the waveform cannot be viewed in any greater detail because the sweep is triggered by the larger amplitude pulses at the start of the display and a faster sweep rate moves this area of the wave-

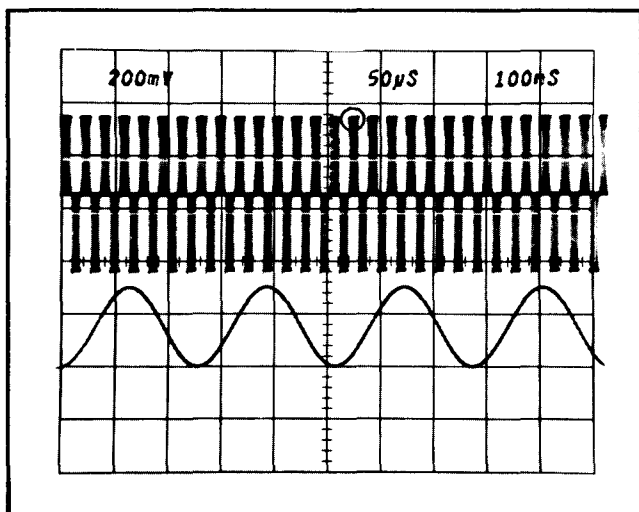

Fig. 2-14. Displaying a complex signal using delayed sweep.

form off the viewing area. The second waveform shows the area of interest magnified 500 times using Delayed Sweep. The DELAY-TIME MULTIPLIER dial has been adjusted so the delayed sweep starts just before the area of interest.

Pulse Jitter Measurements

In some applications it is necessary to measure the amount of jitter on the leading edge of a pulse or jitter between pulses.

1. Set up the display as in the above procedure.
2. Set the B DELAY MODE selector to B STARTS AFTER DELAY. Slight readjustment of the B Triggering

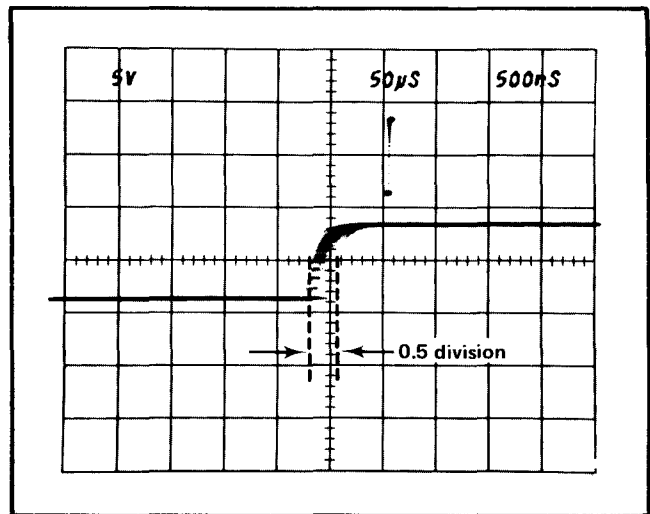

Fig. 2-15. Measuring pulse jitter.

LEVEL control may be necessary to produce as stable a display as possible.

3. Pulse jitter is shown by horizontal movement on the pulse (take into account inherent jitter of Delayed Sweep). Measure the amount of horizontal movement. Be sure both VARIABLE controls are set to CAL.
4. Multiply the distance measured in step 3 by the B TIME/DIV switch setting to obtain pulse jitter in time.

Example. Assume that the horizontal movement is 0.5 divisions (see Fig. 2-15), and the B TIME/DIV switch setting is .5 µs.

Using the formula:

$$\text{Pulse Jitter} = \text{horizontal jitter (divisions)} \times \text{B TIME/DIV setting}$$

Substituting the given values: Pulse Jitter = 0.5 X 0.5 µs

The pulse jitter is 0.25 microseconds.

SECTION 3

CIRCUIT DESCRIPTION

Change information, if any, affecting this section will be found at the rear of the manual.

Introduction

This section of the manual contains a description of the circuitry used in the 7B71. Detailed block diagrams are used to show the interconnections between the stages in each major circuit and the relationship of the front-panel controls to the individual stages.

A complete block diagram is located in the Diagrams Section at the rear of this manual. This diagram shows the overall relationship between all of the circuits. Complete schematics of each circuit are also given in the Diagrams Section. Refer to these diagrams throughout the following circuit description for electrical values and relationship.

BLOCK DIAGRAM

General

The following discussion of the block diagram at the rear of this manual is provided to aid in understanding the overall concept of the 7B71 before the individual circuits are discussed in detail. Each block represents a major circuit within this instrument.

The selection of INTERNAL or EXTERNAL triggering is made in the Trigger Input circuit. This stage also sets the gain and DC balance of the external trigger input. To increase the range of the external trigger input, a 10X attenuator network is incorporated in the input of the external trigger amplifier.

The Trigger Amplifier circuit provides amplification and waveshaping of the selected input trigger signal. Level centering, slope selection and coupling controls are contained in this circuit.

The Peak Detector provides the logic necessary for P-P AUTO mode operation. The peak sensing circuits set the range of the LEVEL control to allow triggering over most of the range of the input signal. This circuit contains level, mode, coupling and source controls.

The Trigger Generator circuits produce an output pulse which initiates the sweep signal produced by sweep gener-

ator circuits. The sweep gate multivibrator produces a Sweep Gate for use by the indicator oscilloscope. The bright-line auto feature which provides a free-running trace in the absence of triggering signals is contained in this stage. The TRIG'D light is also connected to the bright-line auto circuit to indicate the presence of a trigger signal.

The Sweep Generator circuit produces a linear sawtooth output signal when initiated by the trigger generator. The slope of the sawtooth produced by the sweep generator is controlled by the TIME/DIV switch setting. The operating mode of the sweep generator is controlled by the TRIGGERING MODE switch. In the P-P AUTO and AUTO positions, the absence of a trigger signal causes the sweep to free run. In the NORM position, a horizontal sweep is initiated only when triggered by an adequate trigger signal. The SINGLE SWEEP position allows only one sweep to be initiated after the circuit is reset with the RESET button or by the remote reset control.

The Horizontal Preamp is a single-ended to push-pull amplifier. The output of the sweep generator circuit is amplified by this circuit to produce horizontal deflection for the oscilloscope. This circuit contains a 10 times magnifier to increase the sweep rate ten times in any TIME/DIV switch setting. Horizontal positioning is incorporated in this stage.

DETAILED CIRCUIT DESCRIPTION

General

The following circuit analysis is written around the detailed block diagrams which are given for each major circuit. These detailed block diagrams give the names of the individual stages within the major circuits and show how they are connected together. The block diagrams also show the inputs and outputs for each major circuit and the relationship of the front panel controls to the individual stages. The names assigned to the individual stages on the detailed block diagrams are used throughout the following discussion.

TRIGGER INPUT

Input Source

The internal trigger signal from the vertical deflection system is coupled directly through this stage to the trigger

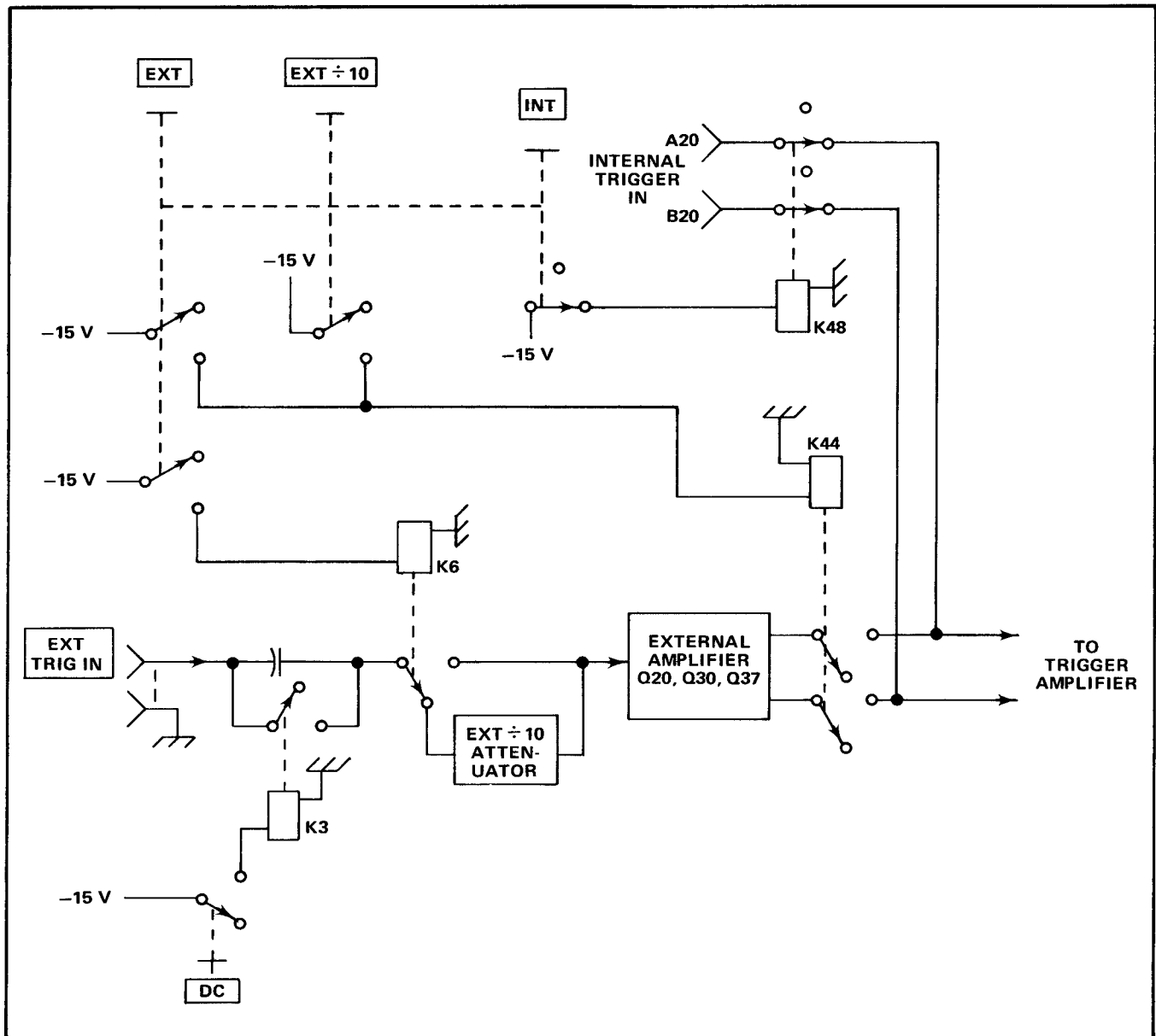

Fig. 3-1. Simplified block diagram of the trigger input.

amplifier. The external trigger signal can be AC or DC coupled to the external input amplifier. See Fig. 3-1 for a simplified block diagram of the Trigger Input Stage.

External Input Amplifier

The external signal is converted from single-ended to push-pull by paraphrase amplifier Q20A and Q20B. The gain of this amplifier is set by R25 for a push-pull gain of 0.2. R37 is used to DC balance the output and is adjusted for a voltage null between the push-pull output lines. A divide-by-10 attenuator network in the input to this amplifier can be selected by the front panel EXT ÷ 10 push-button to extend the triggering level range of the unit.

TRIGGER AMPLIFIER

General

The Trigger Amplifier circuit provides slope and level selection of the trigger signal applied to the Trigger Generator. The P-P AUTO feature is also incorporated in this circuit. Other controls provided in this circuit are AC LF REJ, DC, AC HF REJ and LINE TRIGGERING SOURCE. Fig. 3-2 shows a detailed block diagram of the Trigger Amplifier circuit. A schematic of this circuit is shown on diagrams 2 and 3 at the rear of the manual.

Input Stage

The trigger signal (internal or external as selected by the SOURCE switch) is applied push-pull to the bases of Q107

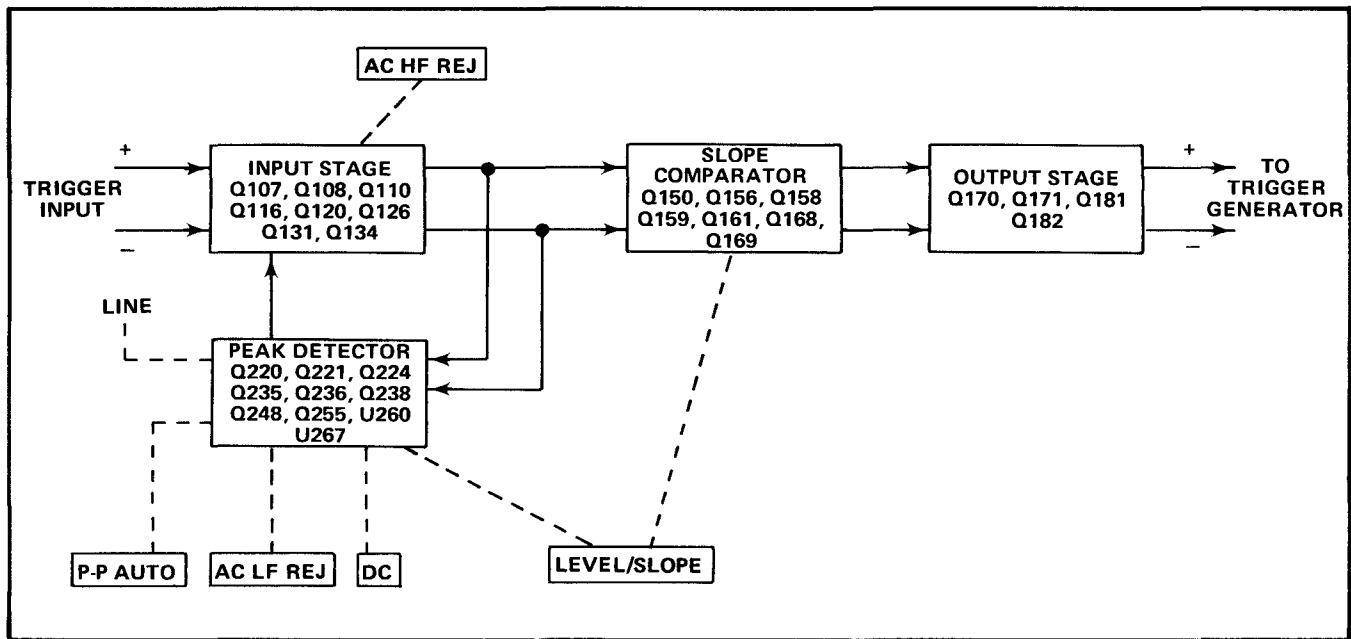

Fig. 3-2. Simplified block diagram of the trigger amplifier.

and Q108. Impedance compensating networks R100, C100, L100 and R101 at the base of Q107 and R104, C104, L104 and R103 at the base of Q108 provide a 50 ohm input for the trigger signal. Q126 with voltage divider network R126, R127, R128 provides a DC reference level for Q116. Q120, R119, R120, R121, R122 and the output of the peak detector circuit provides a variable voltage source for Q110. R121 is adjustable to DC balance this stage with the LEVEL control set to the 9:00 o'clock position of rotation (centered on the positive slope). Q110-R111 and Q116-R117 provide the current source for Q107 and Q108 respectively.

The AC HF REJ control, located in the output of the cascode Input Stage, engages C138 through relay K138 to provide attenuation of signals above 50 kHz.

Peak Detector

The triggering level, with the MODE switch set to P-P AUTO is controlled by the Peak Detector stage. The signal from the trigger amplifier input stage is applied to the Peak Detector peak sensing network. The output of the Peak Detector sets the voltage applied to the LEVEL control (R146A) so that the range of the LEVEL control corresponds to the peak-to-peak amplitude (or less) of the input signal.

The positive portion of the input signal is inverted by the trigger input stage and applied through CR210 to the peak sensing network. C210 charges to the peak value of the input signal. The signal is amplified by Q220-Q224 and

applied to the gate of source follower Q248. Current through Q248 decreases and the voltage at the wiper of R251 becomes more negative. This negative-going signal is inverted by operational amplifier U260, and applied to the top of LEVEL control R146A.

The negative portion of the input signal is applied in-phase to the Peak Detector. The operation of the peak sensing network is the same as that described for the peak positive sensing network. The output at the source of Q255 is applied to the bottom of LEVEL control R146A, as a negative-going voltage which represents the peak negative value of the signal input.

At the end of the positive input signal the voltage at the source of Q248 rises at a rate determined by C248 and R241. The feedback from the source of Q248 aids in holding the charge on C210. For signals with a repetition rate of about 200 hertz or greater, the peak sensing network will remain charged to the peak level of the input signal.

MODE, COUPLING and SOURCE controls are included in the output stage of the Peak Detector.

Slope Comparator

The Slope Comparator is the electronic equivalent of a double-pole double-throw switch. With the SLOPE switch set for positive slope triggering, Q158-Q159 are on and Q161-Q168-Q169 are off. For negative slope triggering, Q161-Q168-Q169 are on and Q158-Q159 are off. R155 adjusts the negative P-P AUTO triggering when the LEVEL/SLOPE control is set to the negative slope.

Output Stage

The output of the slope comparator is applied through the Output Stage to the trigger generator circuit. Diodes CR181 and CR182 limit the push-pull output of the trigger amplifier to about one volt peak-to-peak.

TRIGGER GENERATOR

Trigger Pulse Generator

The Trigger Pulse Generator (see Fig. 3-3) shapes the output of the Trigger Amplifier to provide a trigger pulse with a fast leading edge. Tunnel diode VR304 is quiescently in its low-voltage state. The signal from the Trigger Amplifier switches it to its high-voltage state, causing a negative-going fast rise pulse at the base of Q317 and a positive-going pulse at the base of Q309. The output of the Trigger Pulse Generator at the collector of Q317 is a positive-going fast rise pulse which is applied to the Sweep Gate Stage. The output at the collector of Q309 is a negative-going pulse which is applied to the bright-line Auto circuit. VR304 reverts back to its low-voltage state when the signal from the Trigger Amplifier decreases sufficiently. VR304 runs at the repetition rate of the input signal.

Sweep Gate Stage

The Sweep Gate Stage produces a negative-going step to start the Sweep Generator and a positive gate for use in the oscilloscope.

The positive-going pulse from the Trigger Pulse Generator enables CR319, opening an additional current path for VR358, the sweep gate tunnel diode. VR358 switches to its high-voltage state, applying a positive signal to the base of Q360 (part of the bistable sweep gate multivibrator). The collector voltage of Q360 decreases, producing the negative-going step used to enable the Sweep Generator. When Q360 turns on, emitter-coupled Q368 is turned off to produce the positive edge of the sweep gate output. The sweep gate multivibrator remains in this state (Q360 on and Q368 off) until it is reset by the sweep reset multivibrator (part of the Sweep Generator) at the end of the sweep.

At the end of the sweep, the negative-going lockout gate from the sweep reset multivibrator is applied to the base of Q326 turning it off. Emitter-coupled Q328 is turned on, taking current from the sweep gate tunnel diode, VR358, and reverting it to its low-voltage state. This switches the sweep gate multivibrator back to its quiescent state (Q360 off and Q368 on). The circuit remains in this condition (VR358 in its low-voltage state) until the lockout gate returns to its high level at the end of holdoff time.

Triggered Holdoff Stage

The Triggered Holdoff Stage rearms the sweep gate TD, VR358, at the end of holdoff time. During holdoff time VR322 is in its high-voltage state, biasing Q326 off. At the end of holdoff time the lockout gate from the sweep reset multivibrator returns to its high level. This switches VR322

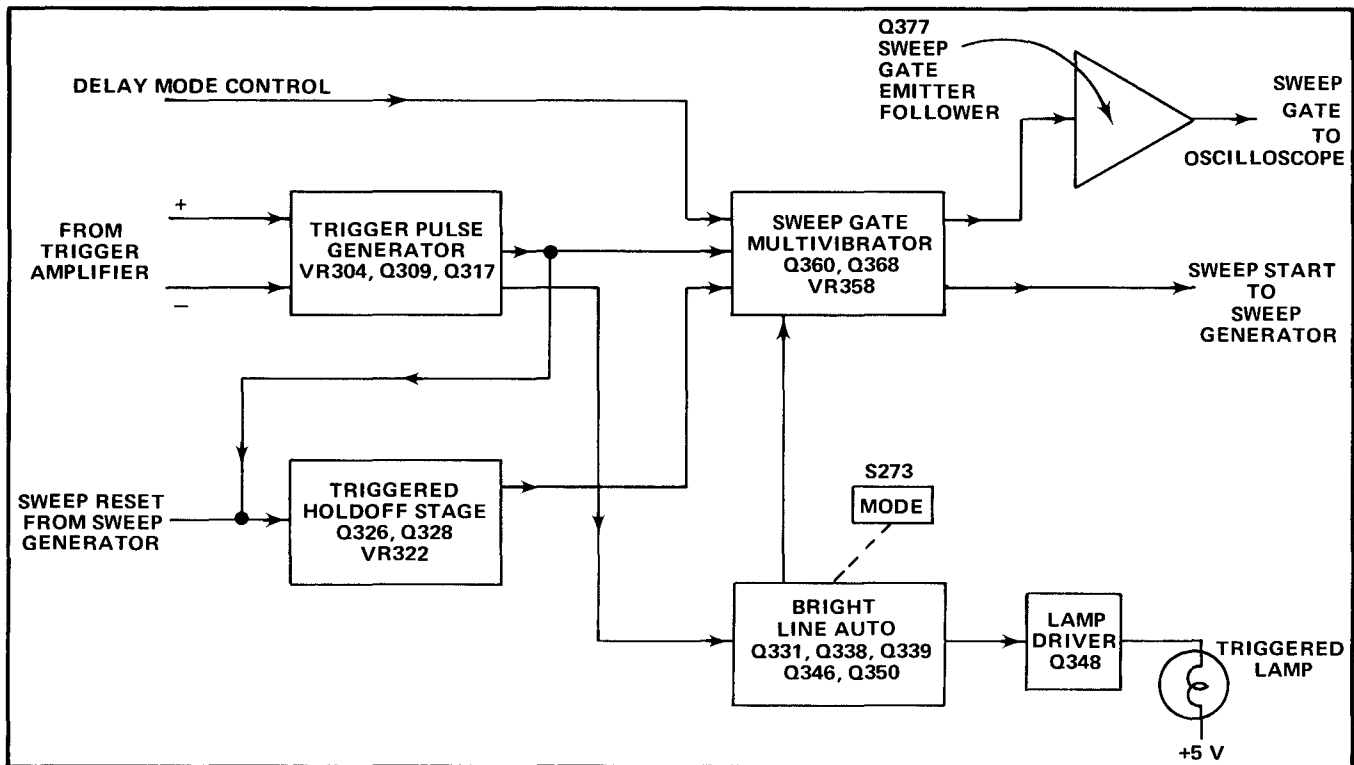

Fig. 3-3. Simplified block diagram of the Trigger Generator circuit.

to its low-voltage state, turning Q326 on. Q328, which is emitter-coupled to Q326, is turned off to rearm the sweep gate TD, VR358.

At high frequencies, double triggering could occur due to the finite risetime of the lockout gate as it returns to its high level. To reduce the incidence of double triggering of the circuit, the trigger pulse from Q317 is differentiated by C324-R324 and superimposed on the lockout gate at the cathode of VR322. Now the sweep is rearmed by one trigger pulse and triggered by the following trigger pulse, maintaining the proper time relationship between input signal and the start of the sweep.

Bright Line Auto

The operation of the sweep gate stage in the P-P AUTO and AUTO MODE is the same as for NORM MODE just described when an adequate trigger signal is present. However, when a trigger signal is not present, a free-running trace is produced in the P-P AUTO and AUTO MODES.

With no trigger signal applied to the circuit, Q331, Q338 and Q339 are off. This allows C339 to charge toward the positive 15 volt supply. As the top of C339 becomes more positive, CR342 is turned on, making the base of Q346 move positive to cutoff. Emitter-coupled Q350 is turned on and the additional current through VR358 switches the TD to its high voltage state, automatically retriggering the sweep each time the lockout gate goes to its high level. The result is that the sweep generator circuit is automatically retriggered at the end of each holdoff period and a free-running trace is produced. Since the trace free-runs at the sweep rate of the sweep generator circuit (as selected by the TIME/DIV switch), a bright reference trace is produced at all sweep rates. The sweep TRIGGERED lamp will not be lit, indicating an untriggered condition.

The sweep TRIGGERED lamp is lit each time an adequate trigger signal is applied to the Pulse Generator. When the trigger signal switches VR304 to its high-voltage state, Q309 is turned off. This turns on Q331, Q338 and Q339. The top of C339 becomes less positive, turning off CR342. Q346 is turned on and its collector goes positive, turning on Q348. Q348 collector current lights the sweep TRIGGERED lamp. When Q346 turns on, its emitter voltage decreases and emitter-coupled Q350 is turned off to disconnect the bright line auto circuit from the sweep gate stage.

When the TRIGGERING MODE switch is in the NORM or SINGLE SWEEP position, the anode of CR355 is clamped to ground. This reverse-biases CR355 and disconnects the bright line auto circuit from the sweep gate stage but allows the TRIG'D light to function.

TIME-BASE GENERATOR

General

The Time-Base Generator circuit (see Fig. 3-4) produces a sawtooth voltage which is changed from single-ended to push-pull by the Horizontal Preamp and used by the Indicator Oscilloscope to provide horizontal sweep deflection on the CRT. In addition, this circuit produces various control signals for use by the Indicator Oscilloscope as well as internal signals for use in the Plug-in.

Normal Trigger Operation

Disconnect Amplifier. The Disconnect Amplifier, Q526, is quiescently conducting current through R523 and the Timing Resistor, R530. The negative-going step from the Sweep Gate Multivibrator is applied to the base of the input emitter-follower, Q402. Q402 couples the negative step to the emitter of Disconnect Amplifier Q526, turning it off. The timing current through Timing Resistor R530, now starts to charge Timing Capacitor C530, enabling the Sweep Generator.

The Disconnect Amplifier is a low leakage transistor to improve timing at low sweep rates and high temperatures. At the end of the sweep Q526 turns on, discharging the Timing Capacitor. CR526 provides isolation between the Disconnect Amplifier and the input emitter-follower during holdoff time.

Sawtooth Sweep Generator. The basic sweep generator circuit is a Miller Integrator Circuit.¹ The current flow through the Disconnect Amplifier is interrupted by the signal from the Sweep Gate Stage. Timing Capacitor C530 now begins to charge through Timing Resistor R530. The Timing Resistor and Timing Capacitor are selected by the TIME/DIV switch (a front panel control) to provide sweep rates as listed on the front panel.

As the Timing Capacitor begins to charge toward the voltage applied to the Timing Resistor, the gate of Q532A, which is tied to the junction of R530-C530, goes negative by the same amount. This decreases the current through Q532A, forcing more current through Q532B. This increase in Q532B drain current flowing through R534 gives a negative-going voltage at the base of Q534. This causes its collector voltage to pull up. The positive side of the Timing Capacitor, being tied to the collector of Q534, is also pulled up. This action results in a positive-going voltage being applied across the Timing Capacitor maintaining a constant charging current and giving a linear rate of rise to the sawtooth output signal. The sawtooth output signal continues to rise in this manner until the Sweep Gate Multivibrator is switched to turn on the Disconnect Amplifier.

¹Jacob Millman and Herbert Taub, "Pulse, Digital and Switching Waveforms", McGraw-Hill, New York, 1965, pp. 540-548.

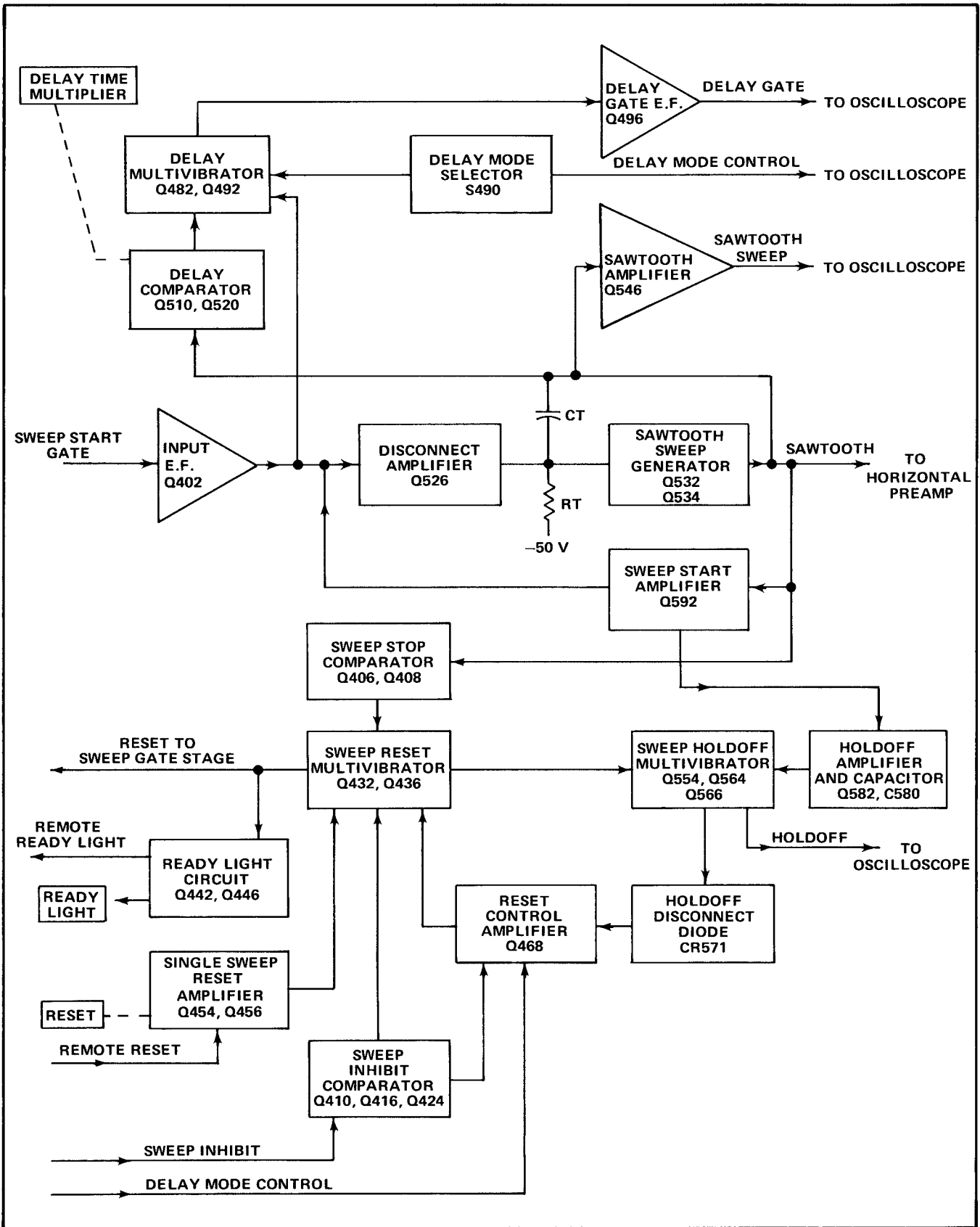

Fig. 3-4. Sweep Generator block diagram.

The sawtooth output from the collector of Q534 is connected to the Horizontal Preamp, the Delay Pickoff circuit, and through R539 to the Sweep Start Amplifier, Sweep Stop Comparator, and through amplifier Q546 to the Indicator Oscilloscope. CR534 protects against reverse emitter-base breakdown of Q534. CR528-CR529 protects against gate-source breakdown of Q532A.

Sweep Start Amplifier. Delay start adjustment R590 adjusts the base voltage of Q592A to set the quiescent voltage of the sawtooth. The collector current of Q592A, flowing through R523, establishes the correct starting point of the sawtooth output signal. L593-R593 prevent oscillations at the faster sweep rates. They are shorted out at the slower sweep rates. CR596 A & B prevent base-emitter breakdown of Q592 A & B.

The sawtooth output signal is applied through R539 to the base of Q592B. The positive-going signal causes Q592B to turn on harder, pulling down its collector voltage. CR596 and CR597 switch the current in R596 to Q592B to make a more definite step. The negative-going voltage at the collector of Q592B is applied through current-limiting diode CR581, to the base of Q582 to charge the holdoff capacitor.

Sweep Stop Comparator. The Sweep Stop Comparator is used to terminate the sawtooth sweep when the sweep has reached a pre-determined level. The circuit components are chosen to set the reference level for sweep termination at approximately 10.5 volts at the base of Q408. The positive-going sawtooth applied to the base of Q408 increases the current through R408-R409. The base of Q406, which is tied to the junction of R408-R409, rises an amount corresponding to the sawtooth amplitude at the base of Q408. This action continues until the emitter of Q406 becomes positive enough to forward bias CR406. When CR406 turns on, the positive rise at the base of Q436 switches the reset multivibrator. The voltage at the collector of Q436 goes negative and this negative-going step applied to the sweep gate circuit ends the sweep.

Holdoff Capacitor and Amplifier. Q582, which is turned on during sweep time, charges the holdoff capacitor. When the sweep ends, Q582 turns off. Now the holdoff capacitor starts to discharge toward -50 volts through R582, and at some sweep speeds, through R580. When the top of C580 discharges negative enough to forward-bias CR574 and CR575, holdoff capacitor voltage is applied to the base of Q554. This drives Q554 to cutoff, switching the holdoff multivibrator to end holdoff time. Voltage limiting diodes CR580 and CR582 protect the base-emitter junction of Q582. CR581 limits the "on" base current of Q582. VR576 and CR576 limit the negative voltage on the holdoff capacitor, C580.

The HF STAB control, R146B, through R583 varies the discharge rate of the holdoff capacitor to provide a stable display at fast sweep rates. This change in holdoff allows sweep synchronization for less display jitter at the faster sweep rates. The HF STAB circuit has little effect at slow sweep rates.

Sweep Holdoff Multivibrator. Q554-Q564 are connected in a bistable Schmitt Trigger configuration. Quiescently Q554 is off and Q564 is on. A positive pulse from the sweep reset multivibrator switches the holdoff multivibrator to its second stable state, Q554 on and Q564 off.

The sweep holdoff multivibrator is returned to its first stable state when the holdoff capacitor has charged negative enough to drive Q554 to cutoff. The fast switching action of the sweep holdoff multivibrator produces sharp leading and trailing edges for the sweep holdoff gate. The output of the multivibrator, coupled through emitter-follower Q566, goes to the indicator oscilloscope and to the holdoff disconnect diode.

During sweep time the voltage on the holdoff capacitor reverse-biases CR575 and the current in R573 switches to CR572, turning off Q468. VR573 determines the time when the current switch takes place. During holdoff time the holdoff disconnect diode, CR571, controls the current available to the reset control amplifier, Q468. The positive-going edge of the holdoff gate turns CR571 on. This moves the emitter of Q468 positive, turning it off. At the end of holdoff time, the negative-going edge of the holdoff gate opens CR571, making the current through R468 available to the reset control amplifier.

Reset Control Amplifier. Q468 provides current to the base of Q436 to switch the sweep reset multivibrator to its reset state. The current through R468 into the emitter of Q468 is controlled by CR571 and CR572 as stated above, or by CR468 as explained under single-sweep operation.

Sweep Reset Multivibrator. The sweep reset multivibrator, Q432-Q436, resets the sweep gate TD at the end of holdoff time. In the reset state, Q432 is off and Q436 is conducting. The top of R438 is pulled up to its high level. The sweep is terminated by current from Q406 moving the base of Q436 positive to cutoff. This switches the multivibrator to its other stable state, Q432 on and Q436 off. The voltage at the top of R438 drops negative to its low level. This negative step is applied to the sweep gate stage to latch the sweep gate TD in its low-voltage state.

At the end of holdoff time Q468 is turned on, driving the base of Q436 less positive. This turns Q436 on and the multivibrator switches back to its reset state. The voltage at

Circuit Description—7B71

the top of R438 is pulled up to its high level. This positive-going step is applied to the Sweep Gate Stage to unlatch the Sweep Gate TD and the sweep circuits are ready for the next sweep to start.

Single Sweep Operation

General. Operation of the Sweep Generator Circuit in the SINGLE SWEEP position of the TRIGGERING MODE switch is similar to operation in the other modes. However, after one sweep has been produced, the Sweep Reset Multivibrator Stage does not reset. All succeeding trigger pulses are locked out until the RESET button is pressed.

In the SINGLE SWEEP position of the MODE switch, -15 volts is removed from the top of R464. CR466 is opened and CR468 becomes forward-biased, opening a current path through R468-CR468-R466. Now, at the end of holdoff, there is no current through Q468 to pull down the base of Q436 and the Sweep Reset Multivibrator does not reset. The circuit remains in this condition until reset by the Single Sweep Reset Amplifier Stage.

Single Sweep Reset Amplifier. The Single Sweep Reset Amplifier produces a negative pulse to reset the Sweep Reset Multivibrator stage so another sweep can be produced in the SINGLE SWEEP mode of operation.

Quiescently, Q454 is conducting hard and Q456 is held cut off. When the RESET button is pressed, CR451 is turned on. This clamps the junction of CR451-CR453 at +0.6 volt. CR453 and CR454 open and the base of Q454 drops to zero volts, turning it off. This turns Q456 on hard, pulling down its collector voltage. This negative-going step applied to C457-CR459 produces a negative pulse at the base of Q436 which is sufficient to reset the sweep reset multivibrator. This enables the sweep gate TD, and the next trigger pulse will produce another sweep on the display. C456 provides positive feedback with a long time-constant to keep Q454 off long enough to prevent switching transients from producing multiple sweeps.

Lamp Driver. In the SINGLE SWEEP MODE, the base of Q446 is connected through CR446, CR448 and CR449 to the collector of Q436. When Q436 is cut off, during holdoff time and until the RESET button is pressed, the base of Q446 is biased to cutoff. When the RESET button is pressed, Q436 is turned on and its collector voltage rises. This positive-going voltage applied to the base of Q446 turns it on (C446 controls turn-on time). Q446 collector voltage drops and the READY lamp turns on. The READY lamp remains on until the end of the sweep, when Q436 is again turned off.

Alternate Operation

In alternate operation, the indicator oscilloscope provides a sweep inhibit current to the emitter of Q410. Q410

provides a low impedance input and a voltage drive for the inhibit comparator, Q416 and Q424. A sweep inhibit current input of 1 mA or greater turns Q410 on. This raises the base voltage of Q416, turning it on and turning Q424 off. The collector current of Q416 pulls the base of Q432 in a negative direction, turning Q432 on and Q436 off to latch the sweep gate TD as described previously.

Delayed Sweep Operation

The 7B71 can be used in the right horizontal (B) compartment of the indicator oscilloscope as a delayed sweep time-base. In this position the delay pickoff circuit and the B DELAY MODE switch will be inoperative.

In this mode of operation the time-base in the left horizontal (A) compartment provides the sweep inhibit current to the emitter of Q410. The sweep inhibit circuit operates as described under Alternate Operation. The A time-base also provides a delay mode control voltage to the anodes of CR462 in the sweep generator and CR334 in the trigger generator.

The delay mode control voltage causes CR462 to conduct, CR463 to turn off, CR464 to conduct and CR466 to turn off. This puts the B sweep in single sweep mode as described under Single Sweep Operation.

During sweep inhibit time Q424 is turned off. This turns off CR428, and with CR463 off, the current from R428 turns on CR469. C469 now charges to about +1.5 volts, turning on Q468. This does not reset the sweep, which is locked out by the conduction of Q416.

When sweep inhibit ends, Q416 turns off, making the base of Q432 more positive. Q424 turns on to open CR469. C469 hold its charge long enough to allow Q468 to reset the sweep at the end of inhibit time. This action allows only one sweep following each time the sweep is inhibited.

The delay mode control voltage is also connected to the sweep gate TD, VR358, through CR357 and R356. With the A time-base B DELAY MODE in B TRIGGERABLE AFTER DELAY, the control voltage is about +3 volts, which does not cause CR357 to conduct and the sweep will wait for the first trigger after the delay interval to run. With the A time-base B DELAY MODE in B STARTS AFTER DELAY the control voltage is about +4.5 volts. This is sufficient to cause CR357 to conduct and increase the current through R356 to the sweep gate TD, VR358. Now the TD will change to its high level state and start the sweep as soon as it is enabled by the sweep reset multivibrator at the end of inhibit current to Q410.

When the INDEPENDENT mode is selected by the A Plug-in DELAY MODE switch, the sweep inhibit is held at

about the 0 mA level. The delay mode control voltage is clamped to ground. The A time-base has no control over the B time-base and each operates as an independent Time-Base.

Delay Pickoff

Delay Comparator. The Delay Comparator stage allows selection of the amount of delay from the start of the A Sweep before the B Sweep Generator is turned on. This stage allows the start of the B Sweep to be delayed from 0 to 10 times the Time-Base A TIME/DIV setting after the A Sweep starts. Then, the B Sweep Generator is turned on and operated at a sweep rate determined by the B TIME/DIV switch setting.

Q520A and Q520B operate as a voltage comparator. The FET with the most positive gate controls conduction. Reference voltage for the comparator is supplied by the DELAY TIME MULTIPLIER, R505, a front-panel control. Delay Stop R500 is provided for calibration of the Delay Pickoff circuit. R501-C501 filter out the power supply ripple to provide stability. This instrument is calibrated so that the major dial markings of the DTM correspond to a major division of the A Sweep horizontal display. For example, if the DELAY TIME MULTIPLIER is set to 5.00, the B Sweep Generator is delayed five divisions of the A Sweep time before it can produce a sweep.

Quiescently, with the DELAY MODE switch set to a delay mode, Q520A having the most positive gate is controlling the Delay Pickoff circuit. The output at the emitter of Q496 is at about +3.6 volts, which inhibits the B sweep. The sawtooth output signal is applied to the gate of Q520B. When the sawtooth voltage rises above the level at the gate of Q520A (established by the DTM) Q520B takes over control of the comparator current. The increased current through Q520B makes the base of Q510B less positive. Q510B turns on and the current through R485 gives a positive-going signal on the base of Q492. Q482-Q492 is a fast switching circuit. The positive-going signal at the base of Q492 increases current through R489 and the emitter of Q482 moves in a positive direction. This decreases the conduction of Q482 and its collector voltage rises. This makes the base of Q492 more positive, reinforcing the original signal. The result of this regenerative action is very fast switching of this circuit.

The negative-going step at the collector of Q492 is applied to the base of Delay Gate Emitter-Follower Q496. The negative-going step at the emitter of Q496 is sent to the Indicator Oscilloscope as the Delay Gate. At the end of the sweep the Delay Pickoff circuit reverts to its quiescent state to produce the positive-going step at the end of the Delay Gate. Q472 aids in quickly returning the Delay Switching Amplifier to its quiescent state. Q472 is held cut off by the sweep start gate during sweep time. At the end of sweep time Q472 turns on, applying a positive-going signal to the base of Q482.

When the DELAY MODE switch is in INDEPENDENT the base of Q492 is clamped at about 0 volts. This turns it on hard and the Delay Gate output is held to its low-level.

Horizontal Preamp

Input Amplifier. Input Amplifier Q764 is an operational (feedback) amplifier which provides stable gain and low input impedance. POSITION control R744 A & B varies the DC level at the base of paraphase amplifier Q784, to position the display horizontally. R771-R772-Q774 supply a stable DC reference level to the base of Q794. Sweep Cal adjustment, R740, adjusts the sawtooth input current. This controls the rate of rise of the sawtooth output of the Paraphase Amplifier.

Paraphase Amplifier. The Paraphase Amplifier, Q784-Q794, takes the single-ended input and converts it to a push-pull output for use in the Indicator Oscilloscope.

The negative-going sawtooth applied to the base of Q784 increases conduction in this half of the Paraphase Amplifier. Through emitter-follower action the negative-going sawtooth signal is also applied to the emitter of Q794, decreasing conduction through this half of the Paraphase Amplifier. The results of these actions are a positive-going sawtooth at the collector of Q784 and a negative-going sawtooth at the collector of Q794.

Magnifier. Relay K780 when energized parallels R782 with R786-R785 to increase the gain of the amplifier by a factor of 10. R785 is adjustable for calibration of the X10 gain. Mag Regis adjustment R795 is used to balance the output for no trace shift when switching from X1 to X10 magnification.

Readout Block

The Readout Block consists of switching resistors and a set of contacts operated by the X10 MAG relay. The switching resistors, selected by the setting of the Readout Switch (part of the TIME/DIV switch), are used to signal the Indicator Oscilloscope of the setting of the TIME/DIV switch.

Refer to Schematic Diagram 7, Timing Switch, at the rear of the manual to find the resistors associated with a particular setting of the TIME/DIV switch. The number 1, 2, or 5 is selected by resistors R704-R705-R706. The number of zeros is selected by resistors R711-R712-R713-R715. The TIME subunit (milli, micro, or nano) is selected by resistors R721-R722-R723-R724. R728-R729 selects the symbol S (seconds). R701-R702 select the symbol > (greater than) when the VAR TIME/DIV knob is in the out (uncal) position. R715 is switched out by the X10 MAG to increase the displayed readout by a factor of 10.

SECTION 4

MAINTENANCE

Change information, if any, affecting this section will be found at the rear of the manual.

Introduction

This section of the manual contains maintenance information for use in preventive maintenance, corrective maintenance and troubleshooting of the 7B71.

PREVENTIVE MAINTENANCE

General

Preventive maintenance consists of cleaning, visual inspection, lubrication, etc. Preventive maintenance performed on a regular basis may prevent instrument breakdown and will improve the reliability of this instrument. The severity of the environment to which the 7B71 is subjected determines the frequency of maintenance. A convenient time to perform preventive maintenance is preceding recalibration of the instrument.

Cleaning

The 7B71 should be cleaned as often as operating conditions require. Accumulation of dirt in the instrument can cause overheating and component breakdown. Dirt on components acts as an insulating blanket and prevents efficient heat dissipation. It may also provide an electrical conduction path.

The covers of the indicator oscilloscope minimize the amount of dust which reaches the interior of the 7B71. Operation of the system without the indicator oscilloscope covers in place necessitates more frequent cleaning. When the 7B71 is not in use, it should be stored in a protected location such as a dust-tight cabinet.

CAUTION

Avoid the use of chemical cleaning agents which might damage the plastics used in this instrument. Avoid chemicals which contain benzene, toluene, xylene, acetone or similar solvents.

Exterior. Loose dust accumulated on the outside of the 7B71 can be removed with a soft cloth or small paint brush. The paint brush is particularly useful for dislodging dirt on and around the front-panel controls. Dirt which remains can be removed with a soft cloth dampened in a mild detergent and water solution. Abrasive cleaners should not be used.

Interior. Dust in the interior of the instrument should be removed occasionally due to its electrical conductivity under high-humidity conditions. The best way to clean the interior is to blow off the accumulated dust with dry, low-velocity air. Remove any dirt which remains with a soft paint brush or a cloth dampened with a mild detergent and water solution. A cotton-tipped applicator is useful for cleaning in narrow spaces.

Visual Inspection

The 7B71 should be inspected occasionally for such defects as broken connections, broken or damaged circuit boards, improperly seated transistors or relay, and heat-damaged parts.

The corrective procedure for most visible defects is obvious; however, particular care must be taken if heat-damaged components are found. Overheating usually indicates other trouble in the instrument; therefore, it is important that the cause of overheating be corrected to prevent a recurrence of the damage.

Transistor and Integrated Circuit Checks

Periodic checks of the transistors and integrated circuits in the 7B71 are not recommended. The best check of transistor and integrated circuit performance is actual operation in the instrument. More details are given under Troubleshooting.

Recalibration

To ensure accurate measurements, check the calibration of this instrument after each 1000 hours of operation or every six months if used infrequently. In addition, replacement of components may necessitate recalibration of the affected circuits. Complete calibration instructions are given in Section 5.

The Performance Check/Calibration Procedure can also be helpful in localizing certain troubles in the instrument. In some cases, minor troubles may be revealed and/or corrected by calibration.

TROUBLESHOOTING

Introduction

The following information is provided to facilitate troubleshooting of the 7B71. Information contained in other sections of this manual should be used along with the following information to aid in locating the defective component. An understanding of the circuit operation is very helpful in locating troubles. See the Circuit Description section for complete information.

Troubleshooting Aids

Diagrams. Circuit diagrams are given on foldout pages in the Diagram Section. The component number and electrical value of each component in this instrument are shown on the diagrams. Important voltages and waveforms are also shown on the diagrams.

Switch Cam Identification. Switch cam numbers shown on the diagrams indicate the position of the cam in the complete switch assembly. The cams are numbered from the front, or mounting end of the switch, toward the rear.

Resistor Color-Code. In addition to the brown composition resistors, some metal-film resistors and some wire-wound resistors are used in the 7B71. The resistance values of wire-wound resistors are printed on the body of the component. The resistance values of composition resistors and metal-film resistors are color-coded on the components (some metal-film resistors may have the value printed on the body) with EIA color code. The color code is read starting with the stripe nearest the end of the resistor. Composition resistors have four stripes which consist of two significant figures, a multiplier and a tolerance value (see Fig. 4-1). Metal-film resistors have five stripes consisting of three significant figures, a multiplier and a tolerance value.

Capacitor Marking. The capacitance values of common disc capacitors and small electrolytics are marked in microfarads on the side of the component body. The white ceramic capacitors used in the 7B71 are color coded in picofarads using a modified EIA code (see Fig. 4-1).

Diode Color Code. The cathode end of each glass-encased diode is indicated by a stripe, a series of stripes or a dot. For most silicon or germanium diodes with a series of stripes, the color code also indicates the type of diode or identifies the Tektronix Part Number using the resistor color code system (e.g., a diode color-coded blue- or pink-brown-gray-green indicates Tektronix Part Number 152-0185-00). The cathode and anode ends of metal-encased diodes can be identified by the diode symbol marked on the body.

Troubleshooting Equipment

The following equipment is useful for troubleshooting the 7B71:

1. Transistor Tester

Description: Tektronix Type 576 Transistor-Curve Tracer or equivalent.

Purpose: To test the semiconductors used in this instrument.

2. Volt-ohmmeter

Description: 20,000 ohms/volt. 0-500 volts DC. Accurate within 3%. Test probes must be well insulated.

Purpose: To measure voltages and resistances.

3. Test Oscilloscope

Description: DC to 200 MHz frequency response, 5 millivolts to 5 volts/division deflection factor. Use a 10X probe.

Purpose: To check waveforms in the instrument.

4. Plug-In Extender

Description: Rigid plug-in extender, Tektronix Part number 067-0589-00.

Purpose: Permits operation of the unit outside the plug-in compartment for better accessibility during troubleshooting.

Troubleshooting Techniques

This troubleshooting procedure is arranged in an order which checks the simple trouble possibilities before proceeding with extensive troubleshooting. The first few checks ensure proper connection, operation and calibration. If the trouble is not located by these checks, the remaining steps aid in locating the defective component. When the defective component is located, it should be replaced following the replacement procedures given under Corrective Maintenance.

1. Check Control Settings. Incorrect control settings can indicate a trouble that does not exist. If there is any question about the correct function or operation of any control, see the Operating Instructions section.

2. Check Associated Equipment. Before proceeding with troubleshooting of the 7B71, check that the equipment used with this instrument is operating correctly. Check that the signal is properly connected and that the probe cable is not defective. The indicator oscilloscope and vertical plug-in unit can be checked for proper operation by substituting another time-base unit which is known to be operating properly (preferably another 7B71 or similar unit). If the trouble persists after substitution, the indicator oscilloscope and/or vertical plug-in unit is defective.

3. Check Instrument Calibration. Check the calibration of this instrument, or the affected circuit if the trouble exists in one circuit. The apparent trouble may only be a result of misadjustment and may be corrected by calibration. Complete calibration instructions are given in the Calibration section.

4. Visual Check. Visually check the portion of the instrument in which the trouble is located. Many troubles can be located by visual indications such as unsoldered connections, broken wires, damaged components, etc.

5. Isolate Trouble to a Circuit. To isolate a trouble to a circuit, note the trouble symptom. The symptom often indicates the circuit in which the trouble is located. For example, if normal triggering can be obtained in the INT mode but cannot be obtained in the EXT mode, the external trigger amplifier or the SOURCE switch is probably at fault. When trouble symptoms appear, use the front-panel controls and the CRT display to try to isolate the trouble to one circuit. When the trouble appears in more than one circuit, check all affected circuits by taking voltage and waveform readings.

Fig. 4-2 provides a guide to aid in locating a defective circuit. This chart does not include checks for all possible defects; use steps 6 and 7 for further troubleshooting. Start from the top of the chart and perform the given checks on the left side of the page until a step is found which is not correct. Further checks and/or the circuit in which the trouble is probably located are listed to the right of this step.

After the defective circuit has been located, proceed with steps 6 and 7 to locate the defective component(s).

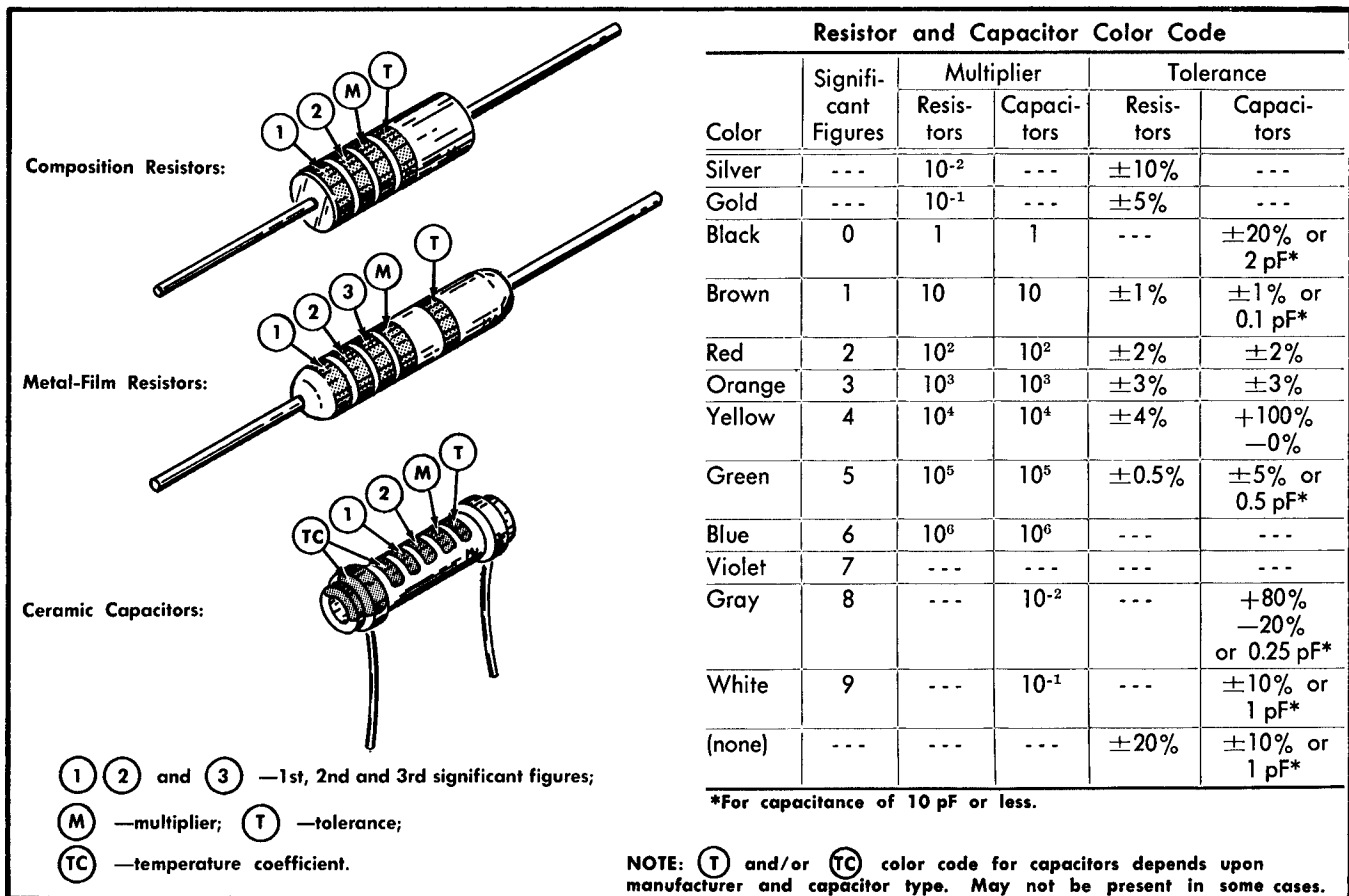

Fig. 4-1. Color-code for resistors and ceramic capacitors.

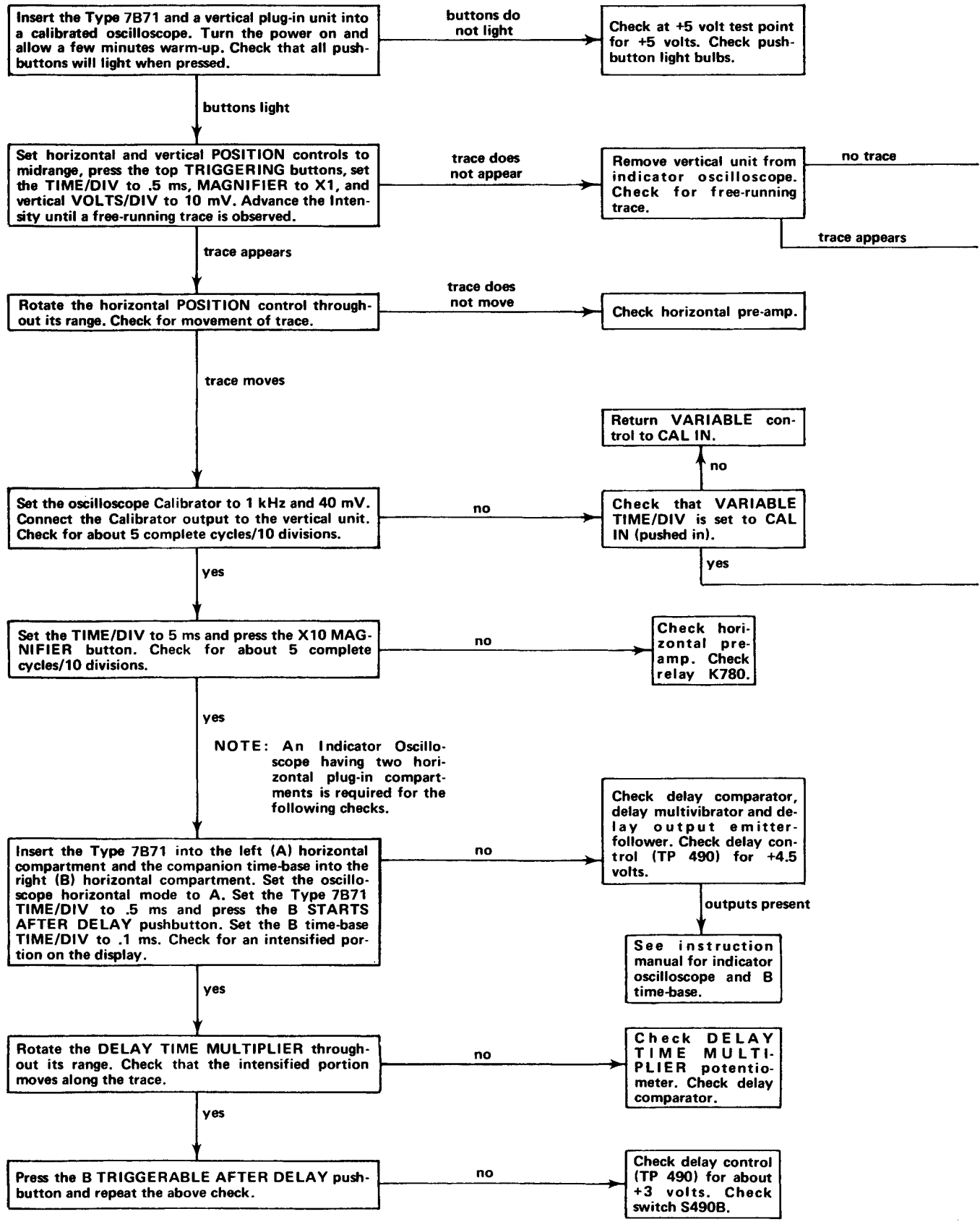
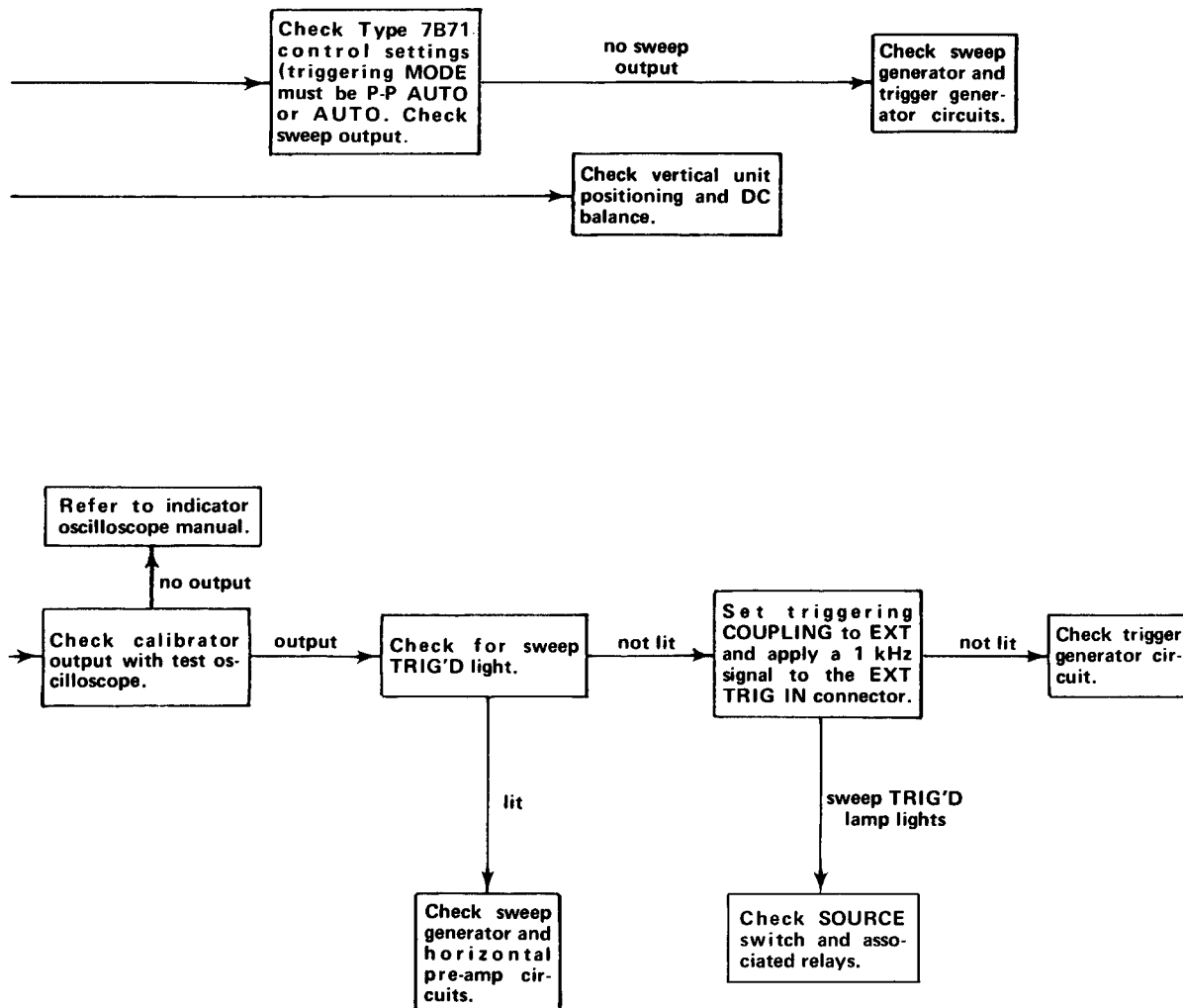

Fig. 4-2. Troubleshooting chart for the 7B71.



For a trouble not covered by this chart, use the troubleshooting methods in steps 6 and 7 of the troubleshooting techniques.

Fig. 4-2. Troubleshooting chart for the 7B71.

6. Check Voltages and Waveforms. Often the defective components can be located by checking for the correct voltage or waveform in the circuit. Typical voltages and waveforms are given on the diagrams.

CAUTION

Do not clamp probe to pin connectors as this may break or damage the connectors.

NOTE

Voltages and waveforms given on the diagrams are not absolute and may vary slightly between instruments. To obtain operating conditions similar to those used to take these readings, see the first diagram page.

7. Check Individual Components. The following procedures describe methods of checking individual components in the 7B71. Components which are soldered in place are best checked by disconnecting one end. This isolates the measurement from the effects of surrounding circuitry.

A. RELAYS. The 7B71 uses two types of relays. The eight pin DPDT relay is symmetrical and may be replaced in its socket facing either direction. The five pin SPDT relay will mate with its socket in one direction only. These relays, which are plugged into the circuit board, may be removed and checked. Using an ohmmeter, check for a DC resistance of 600 ohms across the coil. Each relay can be actuated by applying 15 volts across the coil. With the relay actuated, check the normally open contacts for continuity. When returning the relays to the circuit board, place the five pin relay in the five pin socket and the eight pin relays in the eight pin sockets.

B. TRANSISTORS and INTEGRATED CIRCUITS. The best check of transistor and integrated circuit operation is actual performance under operating conditions. If a transistor or integrated circuit is suspected of being defective, it can best be checked by substituting a new component or one which has been checked previously. However, be sure that circuit conditions are not such that a replacement transistor might also be damaged. If substitute transistors are not available, use a dynamic tester (such as Tektronix Type 576).

C. DIODES. A diode can be checked for an open or shorted condition by measuring the resistance between terminals. With an ohmmeter scale having an internal source of between 800 millivolts and 3 volts, the resistance should be very high in one direction and very low when the leads are reversed.

CAUTION

Do not use an ohmmeter scale that has a high internal current. High currents may damage the diode.

D. RESISTORS. Resistors can be checked with an ohmmeter. Check the Electrical Parts List for the tolerance of the resistors used in this instrument.

E. INDUCTORS. Check for open inductors by checking continuity with an ohmmeter. Shorted or partially shorted inductors can usually be found by checking the waveform response when high-frequency signals are passed through the circuit. Partial shorting often reduces high-frequency response.

F. CAPACITORS. A leaky or shorted capacitor can best be detected by checking the resistance with an ohmmeter on the highest scale. Do not exceed the voltage rating of the capacitor. The resistance reading should be high after initial charge of the capacitor. An open capacitor can best be detected with a capacitance meter or by checking whether the capacitor passes AC signals.

8. Repair and Readjust the Circuit. If any defective parts are located, follow the replacement procedures given in this section. Be sure to check the performance of any circuit that has been repaired or that has had any electrical components replaced.

CORRECTIVE MAINTENANCE

General

Corrective maintenance consists of component replacement and instrument repair. Special techniques required to replace components in this instrument are given here.

Obtaining Replacement Parts

Standard Parts. All electrical and mechanical part replacements for the 7B71 can be obtained through your local Tektronix Field Office or representative. However, many of the standard electronic components can be obtained locally in less time than is required to order them from Tektronix, Inc. Before purchasing or ordering replacement parts, check the parts list for value, tolerance, rating and description.

NOTE

When selecting replacement parts, it is important to remember that the physical size and shape of a component may affect the performance in the instrument, particularly at high frequencies. All replacement parts should be direct replacements unless it is known that a different component will not adversely affect instrument performance.

Special Parts. In addition to the standard electronic components, some special parts are used in the 7B71. These parts are manufactured or selected by Tektronix, Inc. to meet specific performance requirements, or are manufactured for Tektronix, Inc. in accordance with our specifications. These special parts are indicated in the parts list by an asterisk preceding the part number. Most of the mechanical parts used in this instrument have been manufactured by Tektronix, Inc. Order all special parts directly from your local Tektronix Field Office or representative.

Ordering Parts. When ordering replacement parts from Tektronix, Inc., include the following information:

1. Instrument Type.
2. Instrument Serial Number.
3. A description of the part (if electrical, include circuit number).
4. Tektronix Part Number.

Soldering Techniques

WARNING

Disconnect the instrument from the power source before soldering.

Circuit Boards. The components mounted on the circuit boards in the amplifier can be replaced using normal circuit board soldering techniques. Keep the following points in mind when soldering on the circuit boards.

1. Use a pencil-type soldering iron with a power rating from 15 to 50 watts.
2. Apply heat from the soldering iron to the junction between the component and the circuit board.
3. Heat-shunt the lead of the component by means of a pair of long-nosed pliers.
4. Avoid excessive heating of the junction with the circuit board, as this could separate the circuit board wiring from the laminate.
5. Use electronic grade 60-40 tin-lead solder.
6. Clip off any excess lead length extending beyond the circuit board and clean off any residual flux with a flux-

removing solvent. Be careful that the solvent does not remove any printing from the circuit board.

Metal Terminals. When soldering metal terminals (e.g., switch terminals, potentiometers, etc.), use 60-40 tin-lead solder and a 15 to 50 watt soldering iron. Observe the following precautions when soldering metal terminals:

1. Apply only enough heat to make the solder flow freely.
2. Apply only enough solder to form a solid connection. Excess solder may impair the function of the part.
3. If a wire extends beyond the solder joint, clip off the excess.
4. Clean the flux from the solder joint with a flux-removing solvent.

Component Replacement

WARNING

Disconnect the equipment from the power source before replacing components.

Relay Replacement. The relays in the 7B71 are manufactured by Tektronix Inc. If a relay fails, a replacement may be ordered from your local Tektronix Field Office or Representative. The five pin relay sockets on the circuit board will accept only the five pin SPDT relay. It is possible, however, to place a five pin SPDT relay in an eight pin socket intended for use with one of the eight pin relays. This would not damage the instrument or the relay, but would cause a malfunction of the instrument. The eight pin DPDT relays may be placed in their sockets facing either direction, as these relays are symmetrical.

CAUTION

The relays used in this instrument can be damaged by heat. Do not apply a soldering iron to the relay socket until the relay has been removed from the socket.

Transistor and Integrated Circuit Replacement. Transistors and integrated circuits should not be replaced unless actually defective. If removed from their sockets during routine maintenance, return them to their original sockets. Unnecessary replacement of transistors may effect the calibration of this instrument. When transistors and integrated

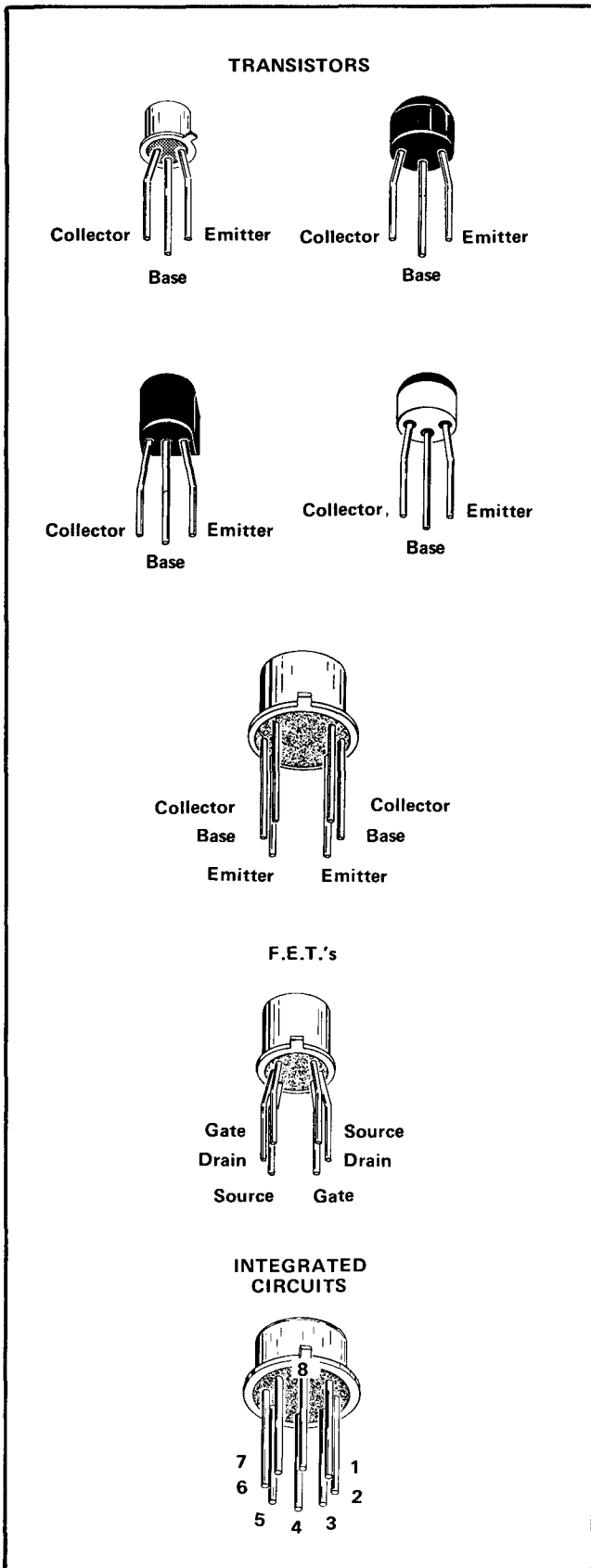

Fig. 4-3. Electrode configuration of transistors and integrated circuits used in this instrument.

circuits are replaced, check the operation of that part of the instrument which may be affected.

Replacement transistors and integrated circuits should be of the original type or a direct replacement. Remount the transistors and integrated circuits in the same manner as the original. Fig. 4-3 shows the lead configurations of the transistors and integrated circuits used in this instrument. This view is as seen from the bottom of the transistor and integrated circuit. When replacing transistors, check the manufacturer's basing diagram for correct basing.

Interconnecting Pins and Pin Socket Replacement. Two types of mating connectors are used for these interconnecting pins. If the mating connector is mounted on a plug-on circuit board, a special socket is soldered into the board. If the mating connector is on the end of a lead, a pin connector is used to mate with the interconnecting pin. The following information provides the replacement procedure for the various types of pins and pin sockets.

CAUTION

When removing the stub of a broken pin connector, it is important not to disturb the old ferrule which is swagged into the circuit board. Use the minimum amount of heat necessary to remove the pin. The new pins are supplied with ferrules intact. Remove the ferrule from the new pin before inserting the pin into the old ferrule in the circuit board. The old ferrule may be reamed out with a .031 drill if necessary. A circuit board pin replacement kit including necessary tools, instructions and replacement pins is available from Tektronix, Inc. Order Tektronix Part No. 040-0542-00.

A. CIRCUIT BOARD PINS. To replace a pin which is mounted on a circuit board, first disconnect any pin connectors. Unsolder the damaged pin and pull it out of the circuit board. Press the new pin into the ferrule in the circuit board. (Notice that the ferrule is not centered on the pin; be sure the replacement pin is positioned in the same manner as the original.) Solder the pin on both sides of the circuit board. If the pin was bent at an angle to mate with a connector, bend the new pin to match the associated pins. The inside radius of this bend should not be less than 0.025 inch.

B. CIRCUIT BOARD PIN SOCKETS. The pin sockets on the circuit boards are soldered to the rear of the board. To replace the sockets, first unsolder the socket (use a vacuum-type desoldering tool to remove excess solder). Straighten the tabs on the socket to remove it from the hole in the circuit board. Place the new socket in the circuit board hole and press the tabs down against the board. Solder the socket tabs to the circuit board.

NOTE

The spring tension of the terminal sockets ensures a good connection between the circuit board and the pin. This spring tension can be destroyed by using the pin sockets as a connecting point for spring-loaded probe tips, alligator clips, etc.

C. END-LEAD PIN CONNECTORS. The pin connectors used to connect the wires to the circuit board pins are clamped to the ends of the associated leads. To replace a damaged pin connector, first remove the old pin connector from the end of the lead. Clamp the new pin connector to the end of the lead. Some of the pin connectors are grouped together and mounted in a plastic holder. These connectors are removed and re-installed as a unit. To provide correct orientation of this multi-connector when it is replaced, an arrow is stamped on the circuit board and a matching arrow is moulded into the plastic housing of the multi-pin connector.

Switch Replacement. Two types of switches are used in the 7B71. The pushbutton switches and the cam-type switch should be replaced as a unit if damaged. The following special maintenance information is provided for the cam-type and pushbutton type switches.

CAUTION

Repair of the cam switch should only be undertaken by skilled maintenance personnel. Switch alignment and contact spacing must be carefully maintained for proper operation of the switch. A cam-type switch repair kit including the necessary tools, instructions and replacement contacts is available from Tektronix, Inc. Order Tektronix Part No. 040-0541-00.

A. CAM-TYPE SWITCH. The cam-type switch (TIME/DIV) consists of a rotating cam, which is turned by the front panel knob, and a set of contacts mounted on an adjacent circuit board. These switch contacts are actuated by lobes on the cam. The TIME/DIV switch can be disassembled for inspection, cleaning, repair or replacement as follows:

1. Remove the four screws which hold the metal cover over the switch. The switch is now open for inspection or cleaning.

2. To completely remove the switch, loosen the set screw on the collar securing the VARIABLE shaft to the VARIABLE potentiometer and pull the shaft completely out the front of the unit. Loosen the two set screws on the TIME/DIV knob and remove the knob. Remove the plastic bushing from the access hole for the TIME/DIV shaft.

3. Remove the sweep generator board by loosening the five securing screws and carefully lifting out.

4. Remove the six screws which hold the cam switch to the interface circuit board and remove the cam switch.

5. To remove the cam from the front support block, remove the retaining ring from the shaft on the front of the switch and slide the cam out of the support block. Do not lose the small detent roller.

6. To replace defective switch contacts, unsolder the damaged contact and clean the solder from the hole in the circuit board. Then position the new contact in the hole so it is properly aligned with the other switch contacts and so it will properly contact the mating area on the circuit board when it is actuated. Solder the new contact into place, being sure that the spring end of the contact has adequate clearance from the circuit board.

7. To re-assemble the switch, reverse the above procedure.

B. PUSH-BUTTON SWITCHES. Use the following procedure to replace the five pushbutton switches:

1. Loosen the set screws and remove the POSITION, LEVEL/SLOPE, TIME/DIV and VARIABLE knobs.

2. Remove the front panel to gain access to the switch mounting screws.

3. To remove the B DELAY MODE switch, remove the two phillips head screws and disconnect the multi-pin connector.

4. To remove the MAGNIFIER switch, remove the phillips head screw and disconnect the multi-pin connector.

5. To remove the TRIGGERING switches, remove the two phillips head screws from each of the MODE, COUPLING and SOURCE switches. Disconnect the following multi-pin connectors: DELAY TIME MULTIPLIER, B DELAY MODE, SWP CAL, POSITION, LEVEL/SLOPE, TRIG'D and MAGNIFIER. Disconnect the pin connectors from the SOURCE and COUPLING switches. Remove the four screws securing the front of the unit to the top and bottom and remove the front of the unit. Remove the TRIGGERING switches (the sweep generator board may have to be removed to take out the TRIGGERING MODE switch).

Maintenance—7B71

Light Bulb Replacement. To replace the light bulbs follow the above procedure to remove the switches. Remove the screw and cover from the back of the switch to expose the light bulb. Unsolder the two leads and remove the light bulb. Cut the leads of the replacement light bulb to the same length as those of the old bulb. Place insulating sleeves over the leads and replace the new bulb in the exact position of the old bulb.

Reassemble by reversing the above procedure.

Instrument Repackaging

If the 7B71 is to be shipped for long distances by commercial means of transportation, it is recommended that

the instrument be repackaged in the original manner for maximum protection. The original shipping carton can be saved and used for this purpose. Repackaging information and/or new shipping cartons can be obtained from Tektronix, Inc. Contact your local Tektronix Field Office or representative.

NOTE

The plug-ins should not be shipped installed in an oscilloscope. The oscilloscope packaging material is not designed to protect the plug-ins.

NOTES

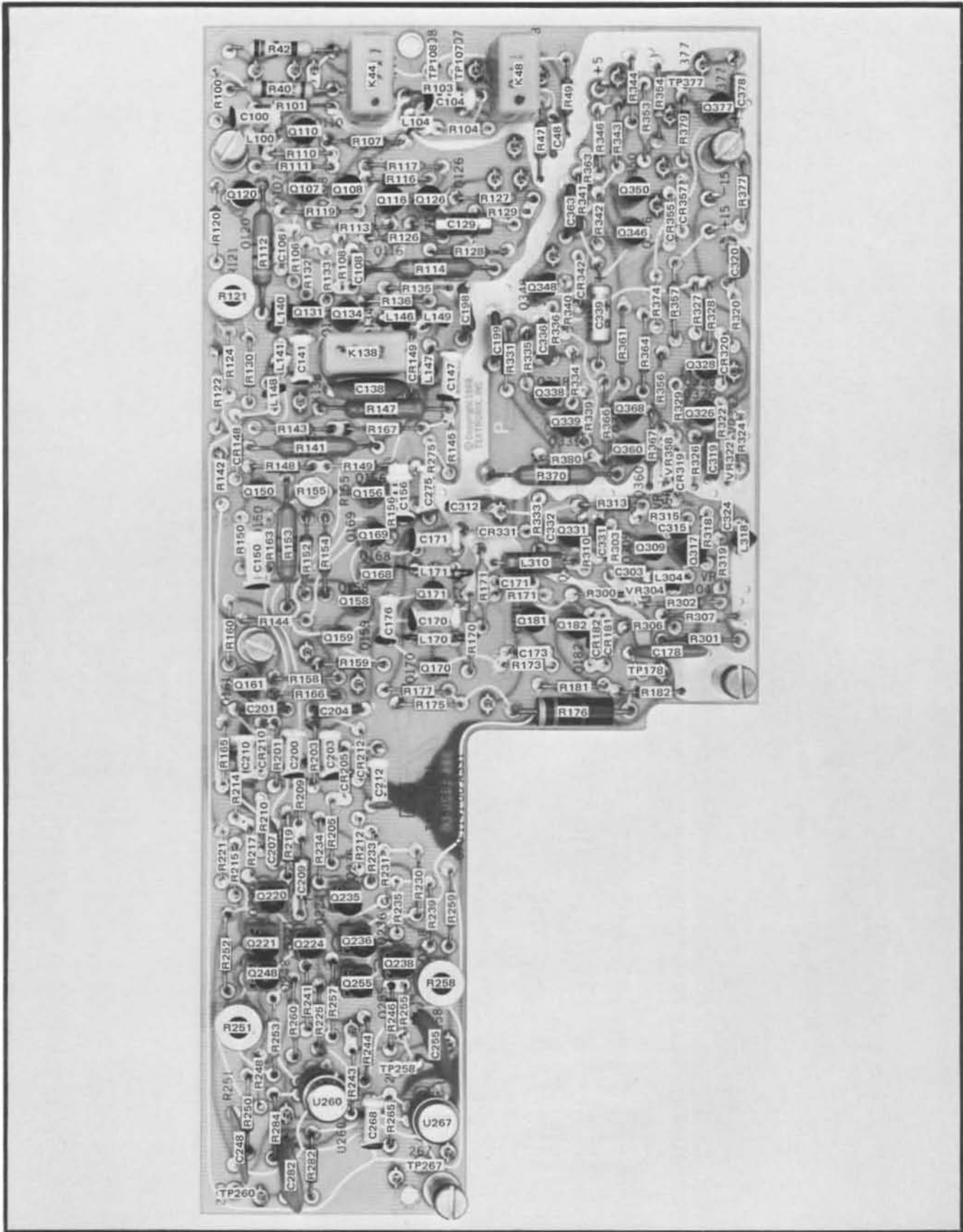

Fig. 4-4. Trigger Generator board (front view) showing location of components.

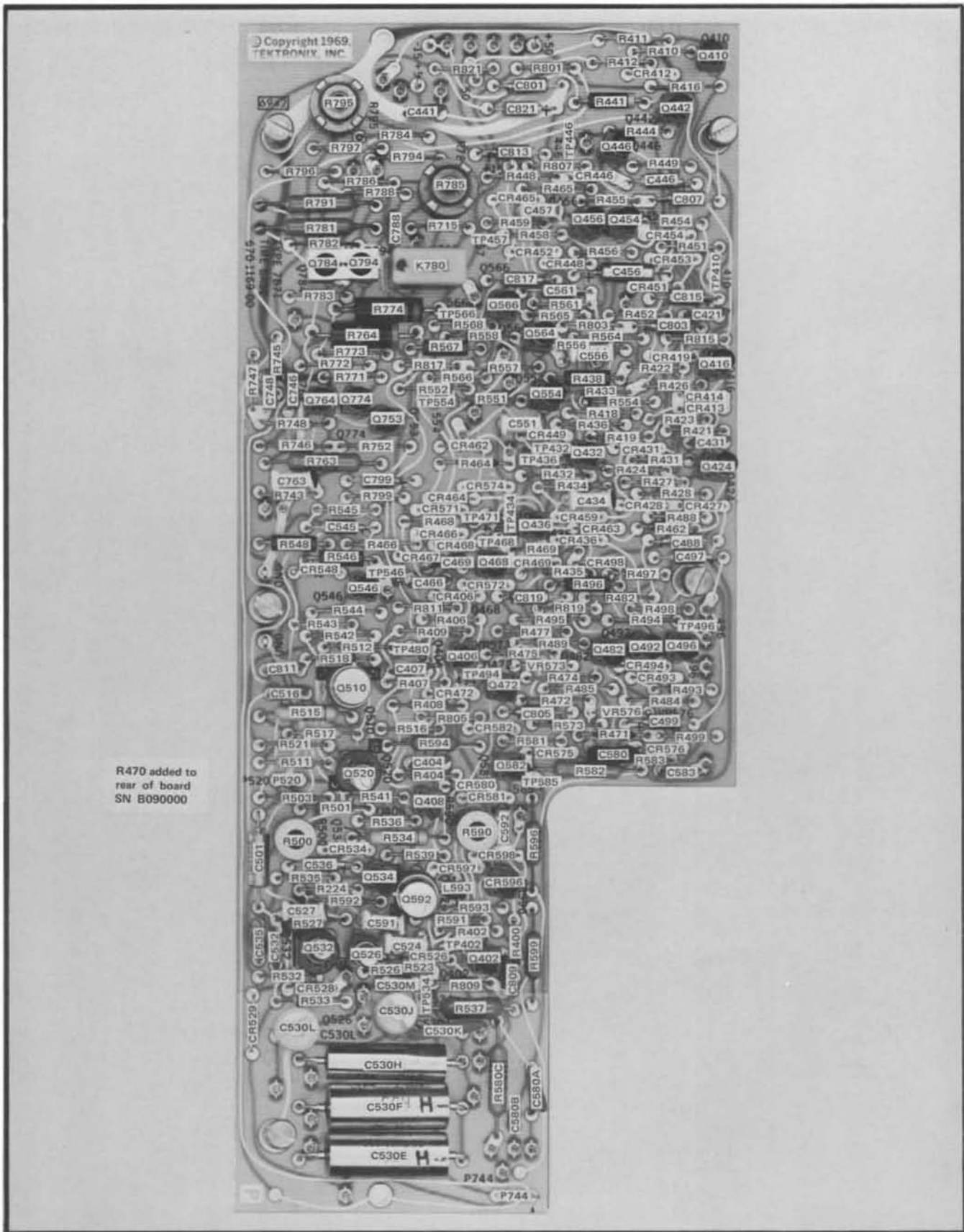

Fig. 4-5. Time Base board (front view) showing location of components.

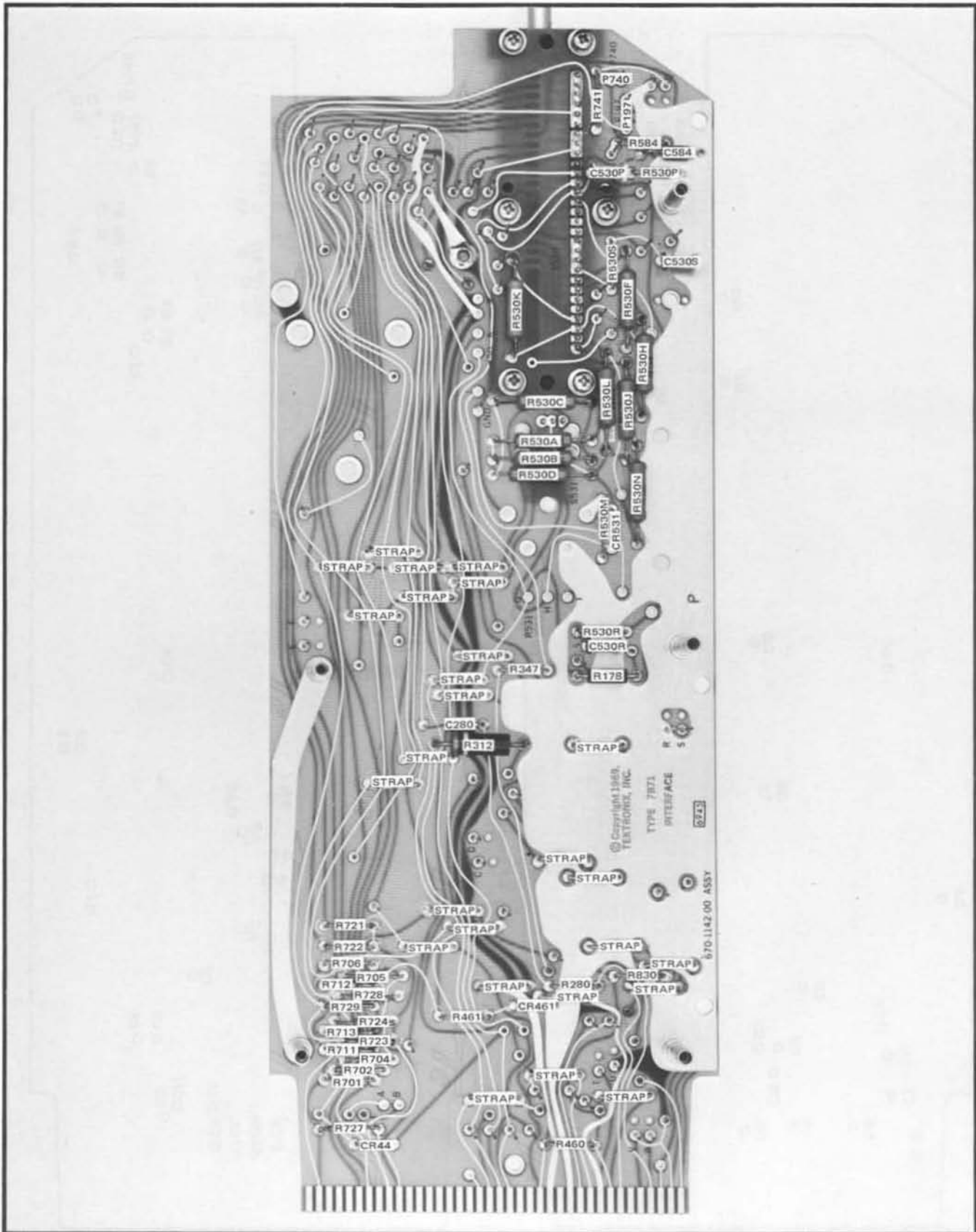

Fig. 4-6. Interface board (left side) showing location of components.

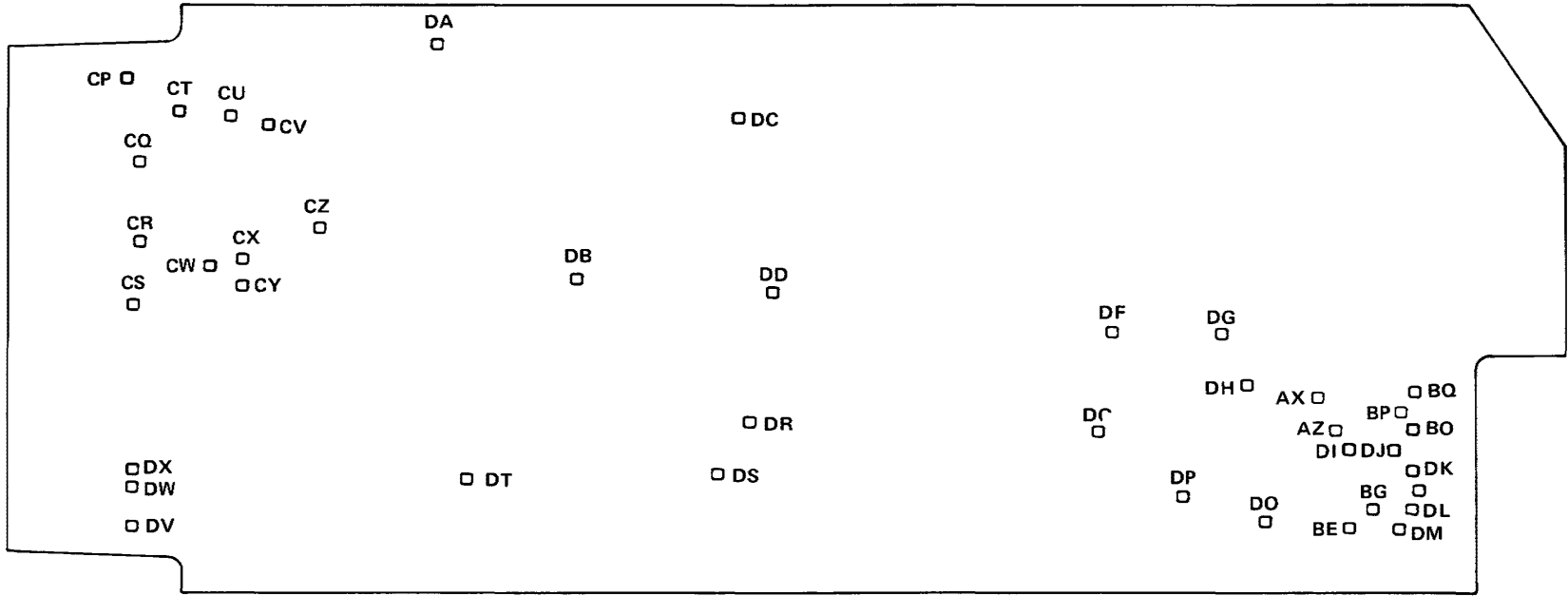

Fig. 4-7. Interface board (right side) showing location of square pin connectors.

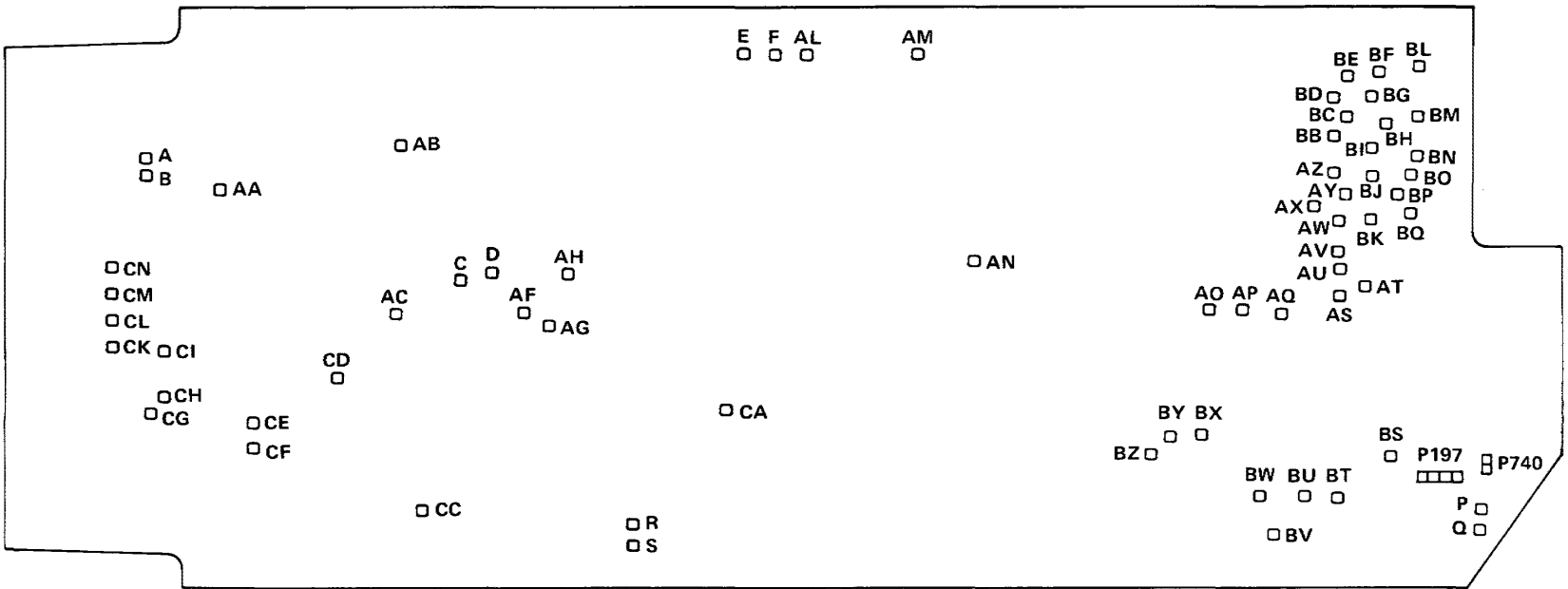

Fig. 4-8. Interface board (left side) showing location of square pin connectors.

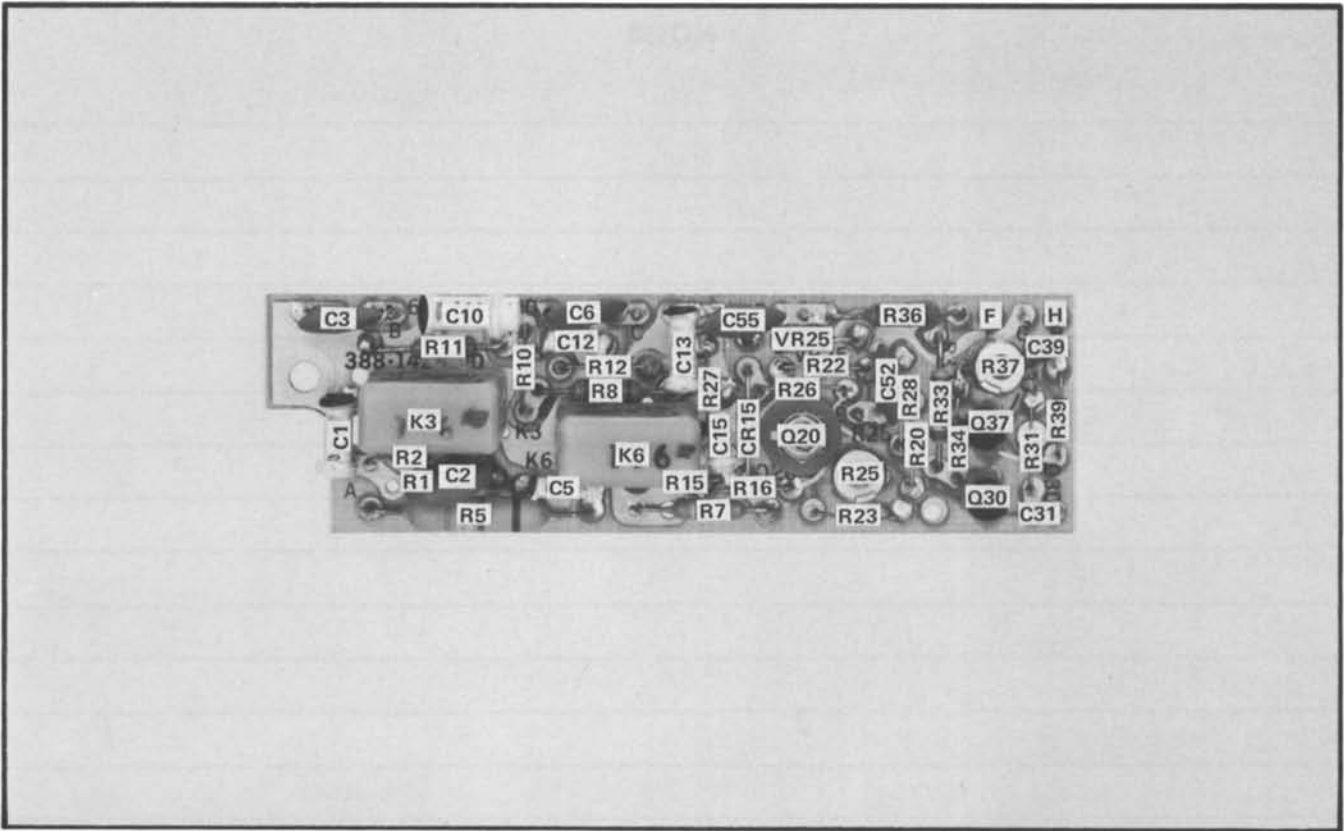

Fig. 4-9. External board showing location of components.

SECTION 5

PERFORMANCE CHECK/CALIBRATION

Change information, if any, affecting this section will be found at the rear of the manual.

Introduction

To assure instrument accuracy, check the calibration of the 7B71 every 1000 hours or every six months if used infrequently. Before calibration, thoroughly clean and inspect this instrument as outlined in the Maintenance Section.

The complete Performance Check/Calibration Procedure can be used to check instrument performance without removing side covers or making internal adjustments by performing all portions except the ADJUST part of the steps. Screwdriver adjustments which are accessible without removing the covers are adjusted as part of the performance check procedure. A note titled PERFORMANCE CHECK ONLY gives instructions which are applicable only to the performance check procedure.

Completion of each step in the complete Performance Check/Calibration Procedure insures that this instrument meets the electrical specifications given in Section 1. For best overall instrument performance, when performing a complete calibration procedure, make each adjustment to the exact setting even if the CHECK is within the allowable tolerance.

A Short-Form Procedure is given prior to the complete procedure. To facilitate instrument calibration for the experienced calibrator, the Short-Form Procedure lists the calibration adjustment necessary for each step and the applicable tolerances. This procedure also includes the step number and title as listed in the complete Performance Check/Calibration Procedure and the page number on which each step begins. Therefore, the Short-Form Procedure can be used as an index to locate a step in the complete procedure. Another feature of the Short-Form Procedure is the spaces provided to record performance data or to check off steps as they are completed. This procedure may be reproduced and used as a permanent record of instrument calibration.

NOTE

All waveforms shown in this procedure were taken with a Tektronix Oscilloscope Camera System. Limits, tolerances and waveforms in this procedure are given as calibration guides and should not be interpreted as instrument specifications except as stated in Section 1.

A partial calibration is often desirable after replacing a component or to touch up an adjustment of a portion of the instrument between major recalibrations. For partial calibration, set the controls as given under Preliminary Control Setting and start with the nearest test equipment picture preceding the desired check or checks. If any controls need to be changed from the preliminary settings for this portion of the calibration procedure, they are listed under the heading Partial Procedure following the equipment required picture. To prevent unnecessary recalibration of other parts of the instrument, readjust only if the tolerance given in the CHECK part of the step is not met. If readjustment is necessary, also check the calibration of any steps listed in the INTERACTION part of the step.

TEST EQUIPMENT REQUIRED

General

The following test equipment and accessories, or its equivalent, are required for complete calibration of the 7B71. Specifications given are the minimum necessary for accurate calibration. Therefore, some of the recommended equipment may have specifications which exceed those given. All test equipment is assumed to be correctly calibrated and operating within the given specifications. If equipment is substituted, it must meet or exceed the specifications of the recommended equipment.

Special Tektronix calibration fixtures are used in this procedure only where they facilitate calibration. These special calibration fixtures are available from Tektronix, Inc. Order by part number through your local Tektronix Field Office or representative.

1. Test time-base compatible with the Tektronix 7700-series oscilloscope. 7B70 used in these checks.

2. Vertical amplifier (2 each) for use with Tektronix 7000-series oscilloscopes. Bandwidth, 200 MHz or greater; deflection factor, 5 volts to less than 50 millivolts. Tektronix 7A16 used in these checks.

3. Oscilloscope. Tektronix 7704.

4. Plug-in extender. Tektronix Part Number 067-0589-00.

Performance Check/Calibration—7B71

5. Low-frequency sine-wave generator. Frequency range, 20 hertz to greater than 50 kilohertz; output amplitude, 150 millivolts to 5 volts. For example, General Radio Model 1310-A Oscillator.

6. Constant amplitude sine-wave generator. Reference frequency, 50 kilohertz; frequency range, 10 megahertz to 100 megahertz; output amplitude variable from 150 millivolts to 5 volts. Tektronix Type 191 recommended.

7. Time-mark generator. Marker outputs, five seconds to five nanoseconds; marker accuracy, within 0.1%. Tektronix Type 184 Time-Mark Generator recommended.

8. Calibration Fixture, Constant Amplitude Signal Generator. Reference frequency, 3 megahertz; frequency range, 65 megahertz to above 200 megahertz; output amplitude, 0.5 to 5 volts peak to peak into 50 ohms; amplitude accuracy, output amplitude constant within 1% of 3 megahertz reference as output frequency changes. Tektronix Part Number 067-0532-00.

9. Standard Amplitude Calibrator. Frequency, 1 kHz; output amplitude, 0.5 mV to 50 V peak to peak in a 1-2-5 step sequence; amplitude accuracy, $\pm 0.25\%$. Tektronix calibration fixture 067-0502-00 recommended.

10. Differential voltmeter. Accuracy, within 1%; resolution, 50 microvolts. For example, Fluke Model 825 A Differential DC Voltmeter.

11. 10X probe. Tektronix Type P6053 recommended.

12. Cable (2 each). Connectors, BNC; Impedance, 50 ohms; length, 42 inches. Tektronix part number 012-0057-01.

13. BNC T connector. Tektronix Part Number 103-0030-00.

14. 50 ohm feedthrough termination (2 each). Tektronix Part Number 011-0049-01.

15. Adapter. GR to BNC female. Tektronix Part Number 017-0063-00.

16. 1X Probe (2 each). Tektronix P6011 probe recommended.

SHORT-FORM PROCEDURE

7B71 _____

Calibration Date _____

Calibrated By _____

1. Adjust Upper Positive Slope P-P AUTO Level (R251) Page 5-5

Requirement: Stable triggering on a 0.5 division 50 kHz signal with the LEVEL/SLOPE control set to 11:30.

Performance: Correct _____ ; Incorrect _____ .

2. Adjust Lower Positive Slope P-P AUTO Level (R258) Page 5-6

Requirement: Stable triggering on a 0.5 division 50 kHz signal with the LEVEL/SLOPE control set to 6:30.

Performance: Correct _____ ; Incorrect _____ .

3. Adjust Negative Slope P-P AUTO Level (R155) Page 5-6

Requirement: Stable triggering on a 0.5 division 50 kHz signal with the LEVEL/SLOPE control set to the negative slope.

Performance: Correct _____ ; Incorrect _____ .

4. Check AUTO Triggering Sensitivity Page 5-6

Requirement: Stable triggering on a 0.3 division 50 kHz signal with the LEVEL/SLOPE control set near 9:00 and 3:00. Performance: Correct _____ ; Incorrect _____ .

5. Check Normal Triggering Sensitivity Page 5-6

Requirement: Stable triggering on a 0.3 division 50 kHz signal with the LEVEL/SLOPE control set near 9:00 and 3:00.

Performance: Correct _____ ; Incorrect _____ .

6. Adjust DC Level Center (R121) Page 5-6
 Requirement: Stable triggering on a 0.3 division 50 kHz signal with LEVEL/SLOPE near 9:00 and COUPLING set to DC.
 Performance: Correct _____ ; Incorrect _____ .
7. Check Single Sweep Mode Page 5-7
 Requirement: After each sweep, further displays are locked out until the RESET button is pressed.
 Performance: Correct _____ ; Incorrect _____ .
8. Adjust External Input Balance (R37) Page 5-7
 Requirement: Adjusted for no potential difference between pins F and H of the External Input Amplifier.
 Performance: Balanced _____ ; Cannot balance _____ .
9. Adjust External Input Gain (R25) Page 5-7
 Requirement: With a one volt signal applied to the input the push-pull output of the External Input Amplifier is 0.2 volt.
 Performance: Adjusted _____ ; Cannot adjust _____ .
10. Check Trigger Bandwidth Page 5-8
 Requirement: Trigger bandwidth meets the specifications given in Section 1. Refer to complete procedure.
 Performance: Correct _____ ; Incorrect _____ list discrepancies. _____
11. Check Internal Trigger Jitter Page 5-10
 Requirement: No more than one nanosecond of jitter with a 150 MHz signal applied.
 Performance: Correct _____ ; Incorrect _____ .
12. Check Line Trigger Source Page 5-10
 Requirement: Stable triggering of the proper polarity on the positive and negative slope of the LEVEL/SLOPE control.
 Performance: Correct _____ ; Incorrect _____ .
13. Check/Adjust Sweep Calibration (SWP CAL, a front panel adjust) Page 5-11
 Requirement: With 1 ms markers applied and TIME/DIV set to 1 ms, check for one marker each division. The second and tenth markers must line up exactly with their respective graticule lines.
 Performance: Correct _____ ; Incorrect _____ .
14. Check/Adjust Magnified Sweep Gain (R785) Page 5-11
 Requirement: With TIME/DIV at 1 ms, MAGNIFIER at X10 and .1 ms markers applied, check for one marker each division.
 Performance: Correct _____ ; Incorrect _____ .
15. Check/Adjust Magnifier Registration (R795) Page 5-11
 Requirement: 0.2 division or less trace shift when switching MAGNIFIER from X10 to X1.
 Performance: Correct _____ ; Incorrect _____ .
16. Check Variable Time/Div Page 5-12
 Requirement: Continuously variable between calibrated settings of the TIME/DIV switch.
 Performance: Correct _____ ; Incorrect _____ .
17. Check/Adjust 5 μ s Timing (C530J) Page 5-13
 Requirement: With 5 μ s markers applied and TIME/DIV set to 5 μ s, check for one marker each division. The second and tenth markers must line up with their respective graticule lines.
 Performance: Correct _____ ; Incorrect _____ .
18. Check/Adjust .2 μ s Timing (C530L) Page 5-13
 Requirement: With .1 μ s markers applied and TIME/DIV set to .2 μ s, check for two markers each division.
 Performance: Correct _____ ; Incorrect _____ .
19. Check Sweep Timing Accuracy Page 5-13
 Requirement: Accuracy over the center eight divisions is within 3% from 5 seconds/division to 1 second/

Performance Check/Calibration—7B71

division; 2% from 0.5 seconds/division to 0.02 microsecond/division.

Performance: Correct _____ ; Incorrect _____ list discrepancies. _____

20. Check Magnified Sweep Timing Page 5-14

Requirement: Magnified timing accuracy over the center eight divisions is within 3.5% from 5 seconds/division to 1 second/division; 2.5% from .5 second/division to 0.02 microsecond/division.

Performance: Correct _____ ; Incorrect _____ .

21. Check/Adjust Delay Start (R590) and Delay Stop (R500) Page 5-15

Requirement: With the DELAY TIME MULTIPLIER set to 1.00, the intensified portion of the sweep starts at the second marker; with the DELAY TIME MULTIPLIER set to 9.00, the intensified portion of the sweep starts at the tenth marker.

Performance: Correct _____ ; Incorrect _____ .

22. Check Delay Time Multiplier Accuracy Page 5-15

Requirement: Accurate within one minor dial division at each major dial setting between 1.00 and 9.00.

Performance: Correct _____ ; Incorrect _____ .

23. Check Delay Time Accuracy Page 5-16

Requirement: Accuracy over the center eight divisions is within 1% and 2 minor divisions for TIME/DIV settings of 1 μ s to 0.5 s; within 2% and 2 minor divisions for TIME/DIV settings of 1 s to 5 s.

Performance: Correct _____ ; Incorrect _____ .

24. Check Delay Time Jitter Page 5-16

Requirement: Jitter does not exceed 1 part in 50,000 of 10 times the TIME/DIV setting.

Performance: Correct _____ ; Incorrect _____ .

25. Check Sweep Length Page 5-17

Requirement: Sweep length must be between 10.5 and 13 divisions.

Performance: Correct _____ ; Incorrect _____ .

26. Check Sweep Holdoff Time Page 5-17

Requirement: Holdoff time is 1.5 times the TIME/DIV setting or less for 5 s/Div to 5 μ s/Div; 3.5 μ s or less for 2 μ s/Div to 0.02 μ s/Div.

Performance: Correct _____ ; Incorrect _____ .

PERFORMANCE CHECK/CALIBRATION PROCEDURE

General

The following procedure is arranged so the 7B71 can be calibrated with the least interaction of adjustments and reconnection of equipment. A picture of the test equipment required for each group of steps is given to aid in identification of the necessary equipment. The control settings continue from the preceding step(s) unless noted otherwise.

The following procedure uses the equipment listed under Test Equipment Required. If other equipment is substituted, control settings or calibration setup may need to be altered to meet the requirements of the equipment used. Detailed operating instructions for the test equipment are not given in this procedure. Refer to the instruction manual for the test equipment if more information is required.

NOTE

This instrument should be calibrated at an ambient temperature of $+25^{\circ}\text{C} \pm 10^{\circ}\text{C}$ for best overall accuracy. If the temperature is outside the given range, see Section 1 for the applicable tolerances.

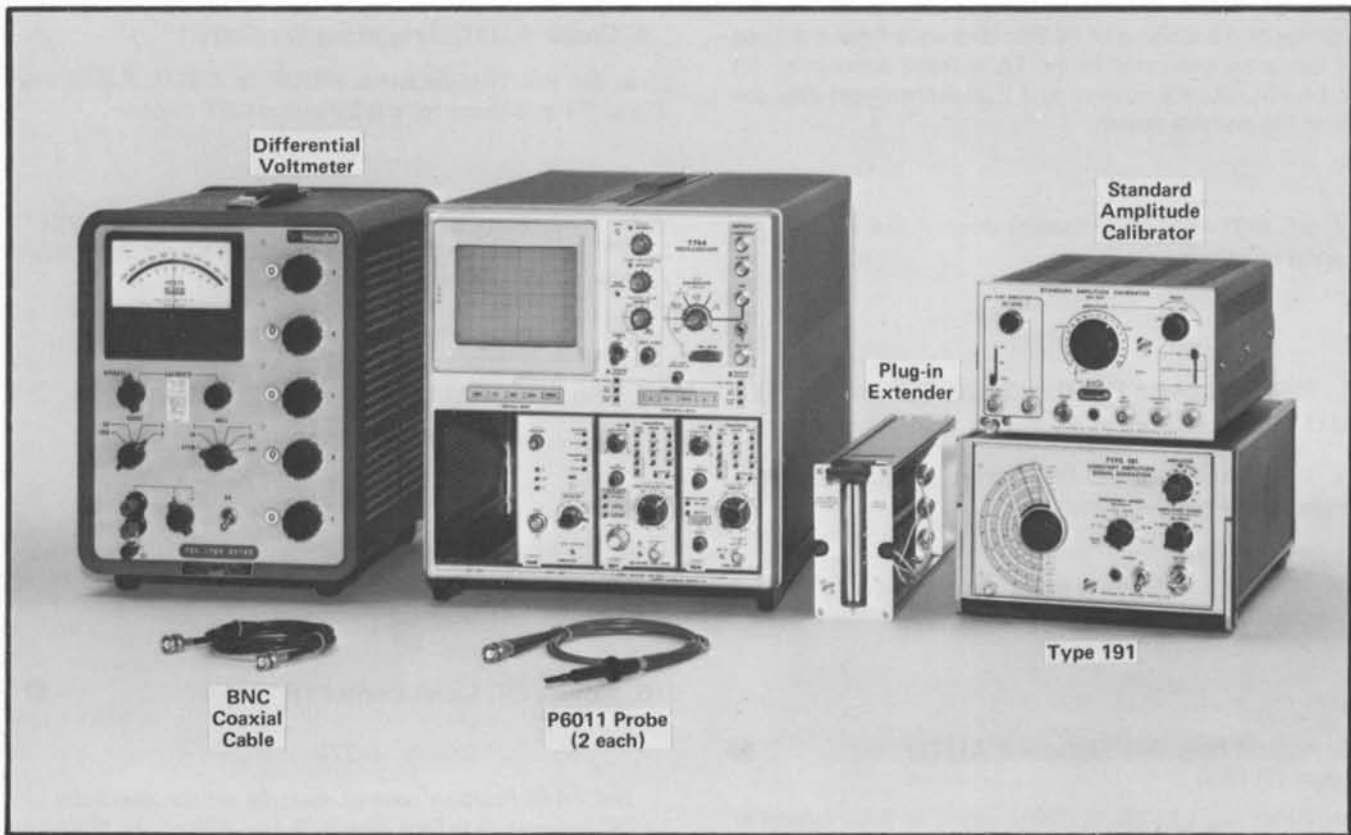

Fig. 5-1. Test equipment required for steps 1 through 9.

Preliminary Control Settings

7B71 (A Horizontal Plug in Compartment)

LEVEL/SLOPE	Centered on Positive Slope (9:00 o'clock)
TRIGGERING MODE	P-P AUTO
COUPLING	AC
SOURCE	INT
POSITION	MIDRANGE
MAGNIFIER	X1
B DELAY MODE	INDEPENDENT
TIME/DIV	20 μ s
VARIABLE	CAL IN

7B70 (Test Time Base in B Horizontal Plug in Compartment)

Level/Slope	Centered on Positive Slope (9:00 o'clock)
Triggering Mode	P-P Auto
Coupling	AC
Source	Int
Position	Midrange
Magnifier	X1
Display Mode	Time Base
Time/Div	20 μ s
Variable Time/Div	Cal In

7A16 (Right Vertical Compartment)

Position	Midrange
Polarity	+ Up
Bandwidth	Full
Volts/Div	.5 V
Coupling	AC

7704 Oscilloscope

A Intensity	CCW
B Intensity	CCW
Vertical Mode	Right
Horizontal Mode	A
A Trigger Source	Vert Mode
B Trigger Source	Vert Mode

Turn the Oscilloscope power on and advance the A Intensity until a free-running trace is observed. Center the trace with the horizontal and vertical Position controls. Allow several minutes warmup before proceeding with calibration.

1. Adjust Upper Positive Slope P-P AUTO Level (R251)

a. Test equipment required is shown in Fig. 5-1.

Performance Check/Calibration—7B71

b. Apply 0.5 division of 50 kHz sine wave from the Type 191 sine-wave generator to the 7A16 Input connector. Set the LEVEL/SLOPE control to 11:30 (control set near the top on the positive slope).

c. **ADJUST—R251 for a stable display. See Fig. 5-2 for location of adjustment.**

2. Adjust Lower Positive Slope P-P AUTO Level (R258) ❶

a. Reset the LEVEL/SLOPE control to 6:30 (near the bottom on the positive slope).

b. **ADJUST—R258 for a stable display. Refer to Fig. 5-2 for location of adjustment.**

3. Adjust Negative Slope P-P AUTO Level (R155) ❶

a. Reset the LEVEL/SLOPE control to 3:00 (centered on the negative slope).

b. **ADJUST—R155 for a stable display. Refer to Fig. 5-2 for location of adjustment. Check for stable triggering over the full 360° range of the LEVEL/SLOPE control.**

4. Check AUTO Triggering Sensivity

a. Set the TRIGGERING MODE to AUTO. Adjust the Type 191 amplitude for a 0.3 division CRT display.

b. **CHECK—**For stable triggering with the LEVEL/SLOPE control near 3:00 and near 9:00. Check for a free-running sweep at all other positions.

5. Check NORMAL Triggering Sensitivity

a. Set the TRIGGERING MODE to NORM.

b. **CHECK—**For stable triggering near 9:00 and near 3:00.

6. Adjust DC Level Center (R121) ❶

NOTE

The 7A16 Position control must be set for zero volts DC between interface pins A20 and B20 of the 7B71 before performing this step.

a. Set the LEVEL/SLOPE control near 9:00 and adjust for a stable display.

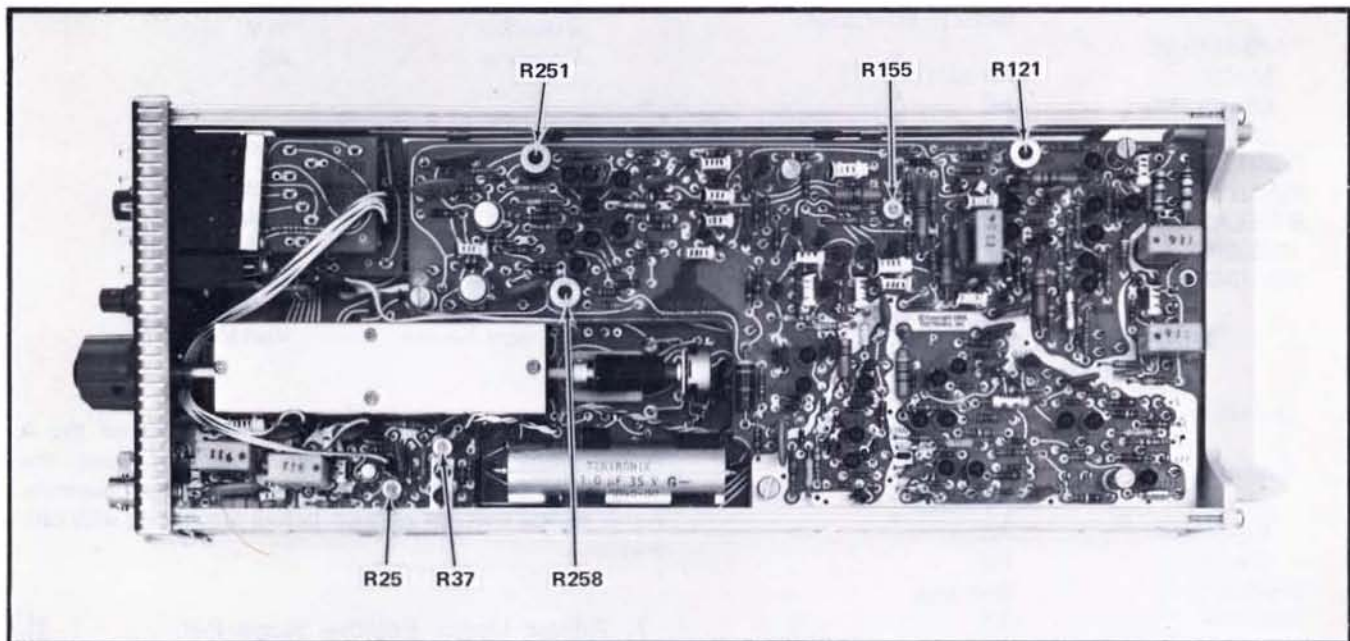

Fig. 5-2. Location of adjustments on Trigger Board.

b. **ADJUST**—Change the TRIGGERING COUPLING to DC and adjust R121 for a stable display. Return the TRIGGERING COUPLING to AC.

7. Check SINGLE SWEEP MODE

a. Adjust the LEVEL/SLOPE control for a stable display and change the TRIGGERING MODE to SINGLE SWP.

b. **CHECK**—Remove the signal from the 7A16. Press the RESET button and check that the READY light is lit. Reconnect the signal to the 7A16 and check that the sweep runs one time. At the end of the sweep the READY light should go out.

8. Adjust External Input Balance (R37) ⓘ

a. Set the TRIGGERING MODE to P-P AUTO, COUPLING to DC and SOURCE to EXT.

b. Connect the differential voltmeter between pins F and H at the rear of the External Input board. See Fig. 5-3 for location of pins.

c. **ADJUST**—R37 for a null reading on the voltmeter. Use the most sensitive voltmeter scale for the final adjustment.

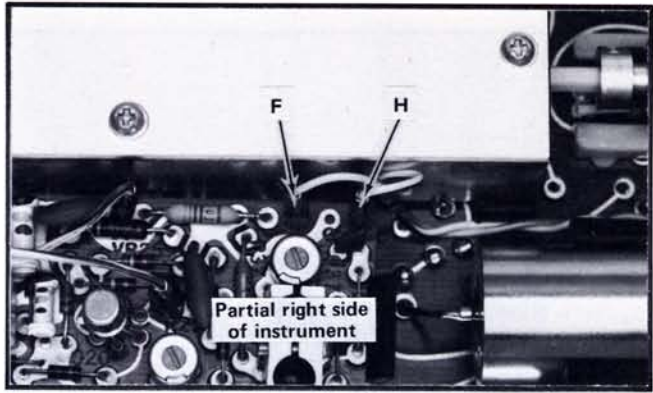

Fig. 5-3. Location of pins for Calibration Steps 8 and 9.

9. Adjust External Input Gain (R25) ⓘ

NOTE

Step 9 requires two 7A16 amplifiers or a dual trace amplifier such as the 7A12.

a. Apply a one volt signal from the standard amplitude calibrator to the EXT TRIG IN connector.

b. Set the Oscilloscope Vertical Mode to Add. Set both 7A16 Volts/Div controls to 50 millivolts. Set the Polarity switch of the 7A16 in the right vertical compartment to Invert. Connect a 1X probe from the left vertical plug in to pin F on the External Input board and a 1X probe from the right vertical plug in to pin H on the External Input board.

c. **ADJUST**—R25 for a four division display on the CRT.

NOTES

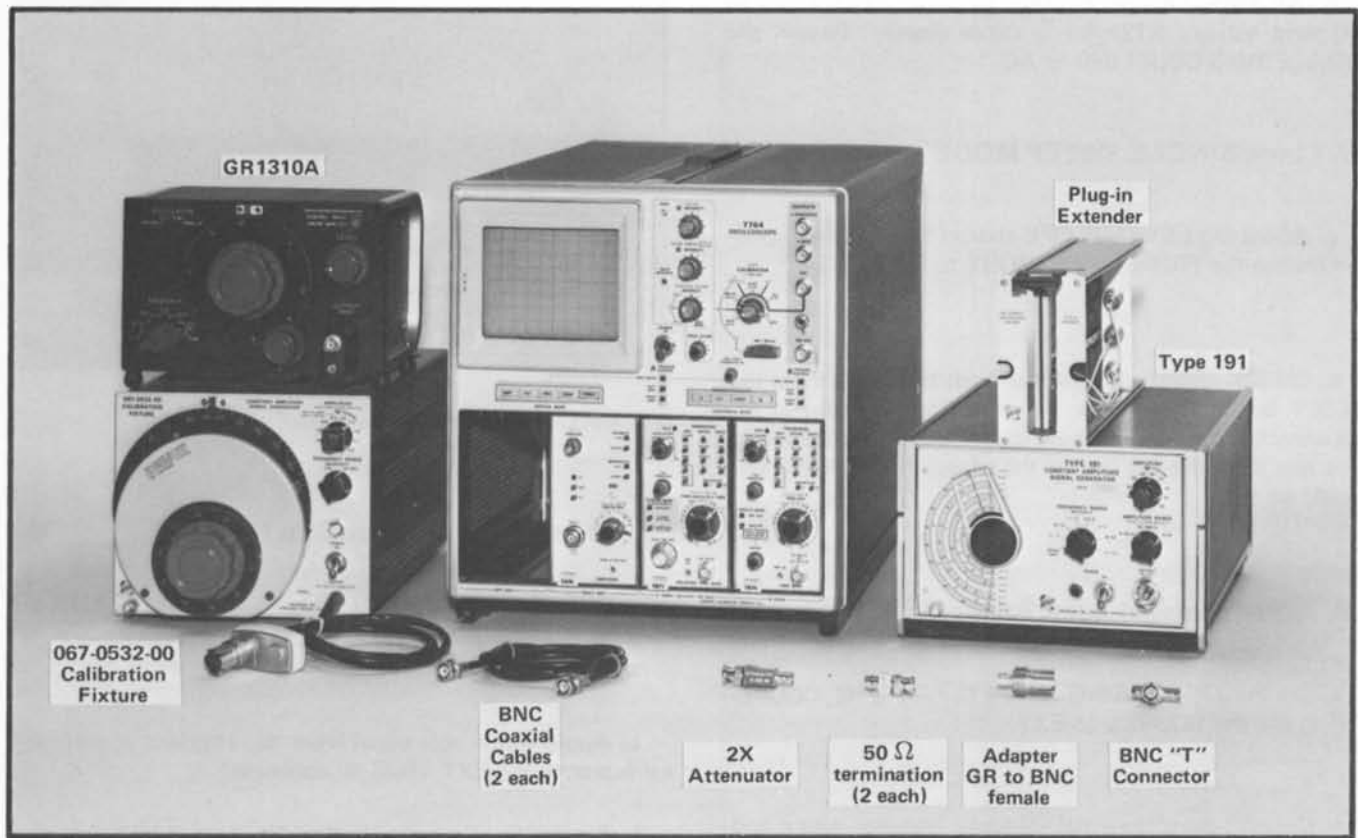

Fig. 5-4. Test equipment required for Steps 10 and 11.

Partial Procedure

To begin a partial procedure with this step, set the controls as given under Preliminary Control Settings except as follows:

TIME/DIV 10 ms

10. Check Trigger Bandwidth

a. Test equipment required is shown in Fig. 5-4.

b. Set the controls as given under Preliminary control settings except as follows:

7B71

TIME/DIV 10 ms

c. Connect a 200 Hz sine wave from the low-frequency sine-wave generator through a "T" connector and coaxial cable to the 7A16 Input and from the other side of the "T"

connector through a coaxial cable and a 2X attenuator to the EXT TRIG IN connector. Adjust the sine-wave generator for a 0.5 division display on the CRT.

d. CHECK—Using the control settings in Table 5-1, check for stable triggering and a lit TRIG'D lamp for each condition listed. Use the TIME/DIV control as necessary for optimum viewing of display.

TABLE 5-1

7B71		Sine-Wave Generator	
COUPLING	SOURCE	Frequency	Amplitude
AC	INT	200 Hz	0.5 div
AC HF REJ	INT	200 Hz	0.5 div
DC	INT	200 Hz	0.5 div
AC LF REJ	INT	30 kHz	0.5 div
AC HF REJ	INT	50 kHz	0.5 div
AC	EXT	200 Hz	125 mV
AC HF REJ	EXT	200 Hz	125 mV
DC	EXT	200 Hz	125 mV
AC LF REJ	EXT	30 kHz	125 mV
AC HF REJ	EXT	50 kHz	125 mV

f. Change the "T" connector from the low-frequency generator to the Type 191 signal generator output connector (using a GR to BNC adapter). Set the Type 191 frequency to 20 MHz and adjust the amplitude for 125 millivolts.

g. CHECK—Using the control settings in Table 5-2, check for stable triggering and a lit TRIG'D lamp for each condition listed.

TABLE 5-2

7B71		Type 191	
COUPLING	SOURCE	Frequency	Amplitude
DC	EXT	20 MHz	125 mV
AC	EXT	20 MHz	125 mV
AC LF REJ	EXT	20 MHz	125 mV
DC	INT	20 MHz	0.5 div
AC	INT	20 MHz	0.5 div
AC LF REJ	INT	20 MHz	0.5 div

h. Change the "T" connector from the Type 191 signal generator to the 067-0532-00 Calibration Fixture output connector. Set the Calibration Fixture frequency to 200 MHz and adjust the amplitude for a 1.5 division display.

i. CHECK—Using the control settings in Table 5-3, check for stable triggering and a lit TRIG'D lamp for each condition listed.

TABLE 5-3

7B71		Calibration Fixture	
COUPLING	SOURCE	Frequency	Amplitude
AC	INT	200 MHz	1.5 div
DC	INT	200 MHz	1.5 div
AC LF REJ	INT	200 MHz	1.5 div
AC	EXT	200 MHz	375 mV
DC	EXT	200 MHz	375 mV
AC LF REJ	EXT	200 MHz	375 mV

j. Change the "T" connector from the 067-0532-00 calibration fixture to the low frequency sine-wave generator output connector. Adjust the sine-wave generator for a 0.3 division display. Reset the TRIGGERING MODE to NORM.

k. CHECK—Using the control settings in Table 5-4, check for stable triggering and a lit TRIG'D lamp for each condition listed.

TABLE 5-4

7B71		Sine-Wave Generator	
COUPLING	SOURCE	Frequency	Amplitude
AC	INT	30 Hz	0.3 div
AC HF REJ	INT	30 Hz	0.3 div
DC	INT	30 Hz	0.3 div
AC LF REJ	INT	30 kHz	0.3 div
AC HF REJ	INT	50 kHz	0.3 div
AC	EXT	30 Hz	75 mV
AC HF REJ	EXT	30 Hz	75 mV
DC	EXT	30 Hz	75 mV
AC LF REJ	EXT	30 kHz	75 mV
AC HF REJ	EXT	50 kHz	75 mV

l. Change the "T" connector from the low-frequency generator to the Type 191 signal generator output connector (using a GR to BNC adapter). Set the Type 191 frequency to 20 MHz and adjust the amplitude for 75 millivolts.

m. CHECK—Using the control settings in Table 5-5, check for stable triggering and a lit TRIG'D lamp for each condition listed.

TABLE 5-5

7B71		Type 191	
COUPLING	SOURCE	Frequency	Amplitude
DC	EXT	20 MHz	75 mV
AC	EXT	20 MHz	75 mV
AC LF REJ	EXT	20 MHz	75 mV
DC	INT	20 MHz	0.3 div
AC	INT	20 MHz	0.3 div
AC LF REJ	INT	20 MHz	0.3 div

n. Change the "T" connector from the Type 191 signal generator to the 067-0532-00 Calibration Fixture output connector. Set the Calibration Fixture frequency to 200 MHz and adjust the amplitude for a 1.5 division display.

o. CHECK—Using the control settings in Table 5-6, check for stable triggering and a lit TRIG'D lamp for each condition listed.

TABLE 5-6

7B71		Calibration Fixture	
COUPLING	SOURCE	Frequency	Amplitude
AC	INT	200 MHz	1.5 div
DC	INT	200 MHz	1.5 div
AC LF REJ	INT	200 MHz	1.5 div
AC	EXT	200 MHz	375 mV
DC	EXT	200 MHz	375 mV
AC LF REJ	EXT	200 MHz	375 mV

Performance Check/Calibration—7B71

11. Check Internal Trigger Jitter

a. Set the 067-0532-00 Calibration Fixture to 150 MHz and adjust the amplitude for a four division display.

b. Set the 7B71 TIME/DIV to .02 microsecond, MAGNIFIER to X10, and SOURCE to INT.

c. CHECK—For no more than 0.5 division (1 nanosecond) of jitter. Disregard any slow drift.

12. Check Line Trigger Source

a. Change the control settings as follows:

	7B71
TIME/DIV	5 ms
TRIGGERING	
MODE	NORM
COUPLING	AC
SOURCE	LINE

	7A16
Volts/Div	1 V
Coupling	AC

b. Connect a probe from the 7A16 Input to interface connector A4 (plug-in connector at the rear of the 7B71). See Fig. 5-5.

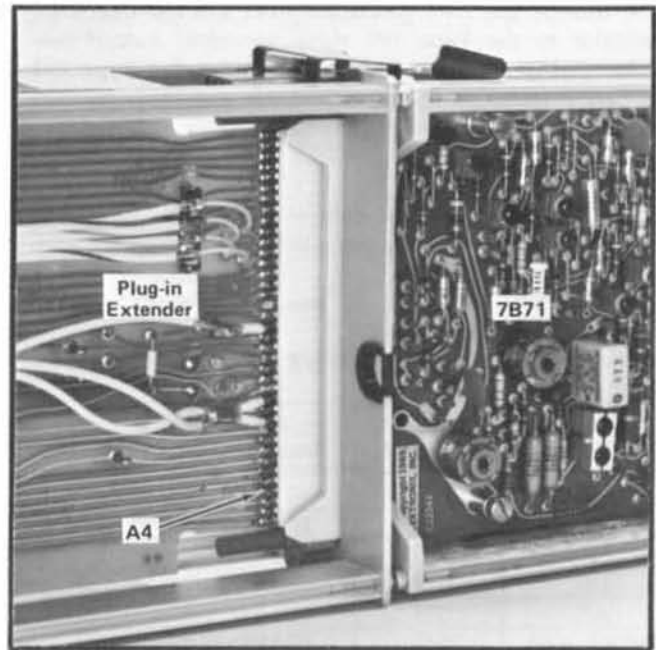

Fig. 5-5. Location of interface connector A4.

c. CHECK—For stable triggering of the proper polarity with the LEVEL/SLOPE control set to the positive slope and to the negative slope.

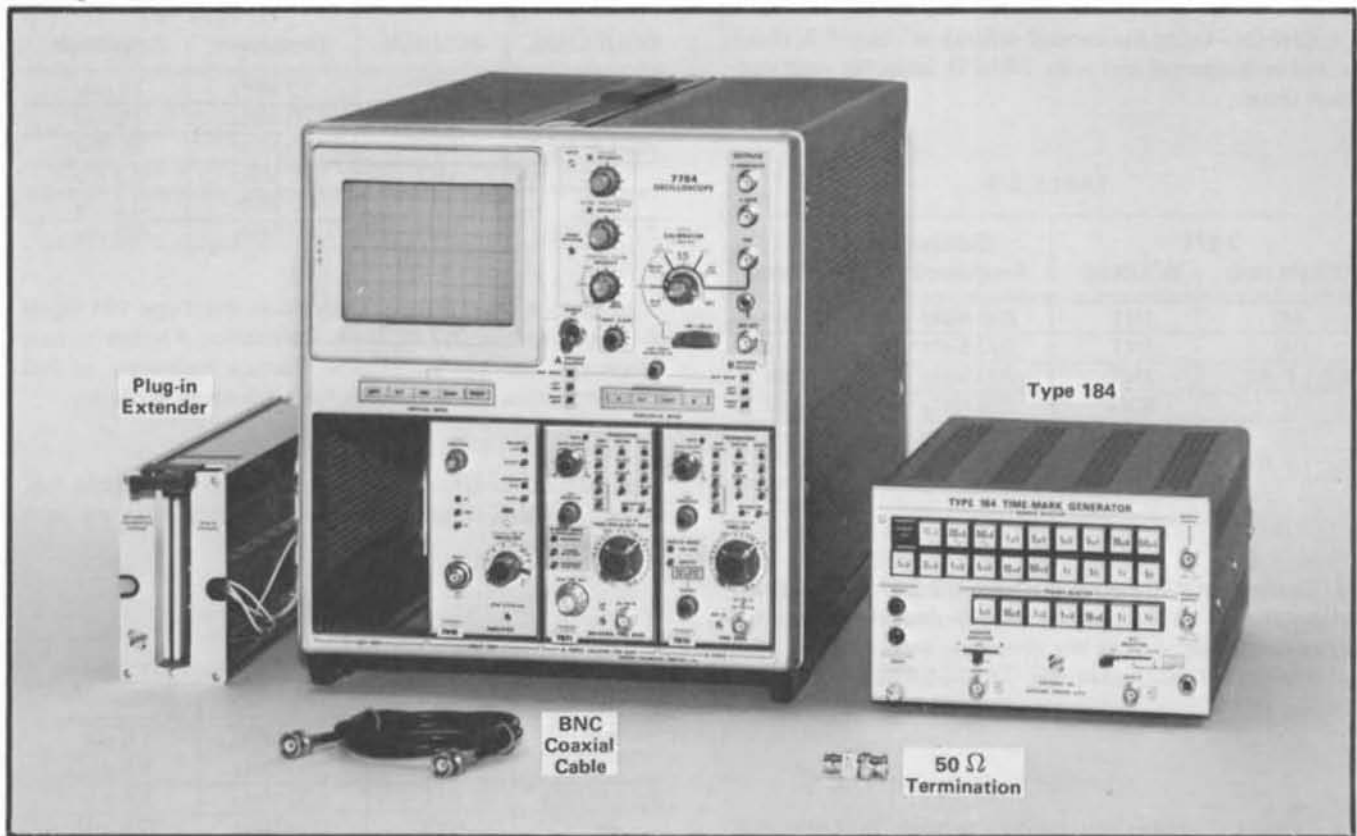

Fig. 5-6. Test equipment required for steps 13 through 25.

Partial Procedure

To begin a partial procedure with this step, set the controls as given under Preliminary Control Settings except as follows:

	7A16
VOLTS/DIV	2 V
	7B71
TIME/DIV	1 ms

13. Check/Adjust Sweep Calibration (SWP CAL, a front-panel adjustment) ❶

- Test equipment required is shown in Fig. 5-6.
- Set the 7B71 TIME/DIV to 1 ms, SOURCE to INT and TRIGGERING MODE to P-P AUTO.
- Apply 1 ms markers from the Type 184 time-mark generator to the 7A16 Input.
- CHECK—CRT display for one 1 ms marker for each division between the second and tenth vertical lines (see Fig. 5-7).

NOTE

Unless otherwise noted, use the center eight horizontal divisions when checking or adjusting timing.

PERFORMANCE CHECK ONLY

Front-panel adjustment; can be adjusted as part of the performance check.

- ADJUST—SWP CAL, a front-panel adjustment, for one marker each division. The second and tenth markers must line up with their respective graticule lines (use the horizontal POSITION control as necessary to line up the display).
- CHECK—The timing accuracy is within 5% over any two division interval within the center eight divisions.
- INTERACTION: Check steps 14, 15, 16, 17, 18, 19, 20.

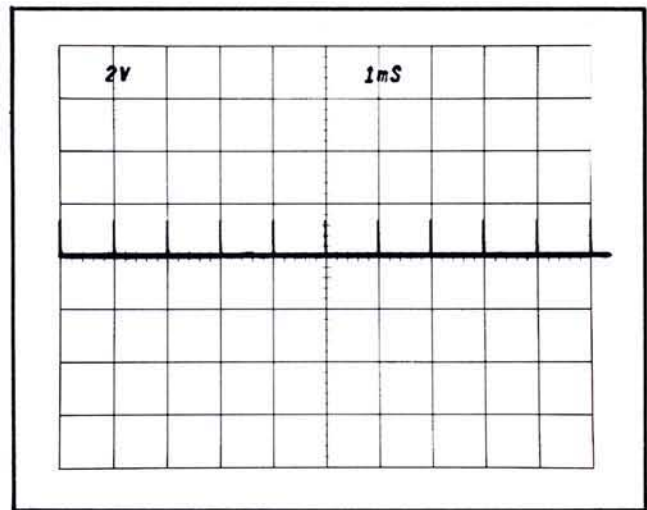

Fig. 5-7. CRT display showing SWP CAL adjustment correctly set.

14. Check/Adjust Magnified Sweep Gain (R785) ❶

- Set the time-mark generator for .1 ms markers.
- Set the 7B71 MAGNIFIER to X10.
- CHECK—CRT display for one .1 ms marker for each division between the second and tenth vertical lines.
- ADJUST—R785, Magnifier Gain, for one marker each division. The second and tenth markers must coincide exactly with their respective graticule lines (use the horizontal POSITION control as necessary to line up the display).
- CHECK—Timing accuracy is within 5% over any two division interval within the center eight divisions.
- INTERACTION: Check steps 15, 20.

15. Check/Adjust Magnifier Registration (R795) ❶

- Set the time-mark generator for 5 ms markers. Set the 7A16 Volts/Div to 1V.
- Position the middle marker to the center vertical line (there are three markers on the total magnified sweep) with the horizontal POSITION control. See Fig. 5-8A.
- CHECK—Set the MAGNIFIER to X1 and check that the middle marker remains at the center vertical line. See Fig. 5-8B.

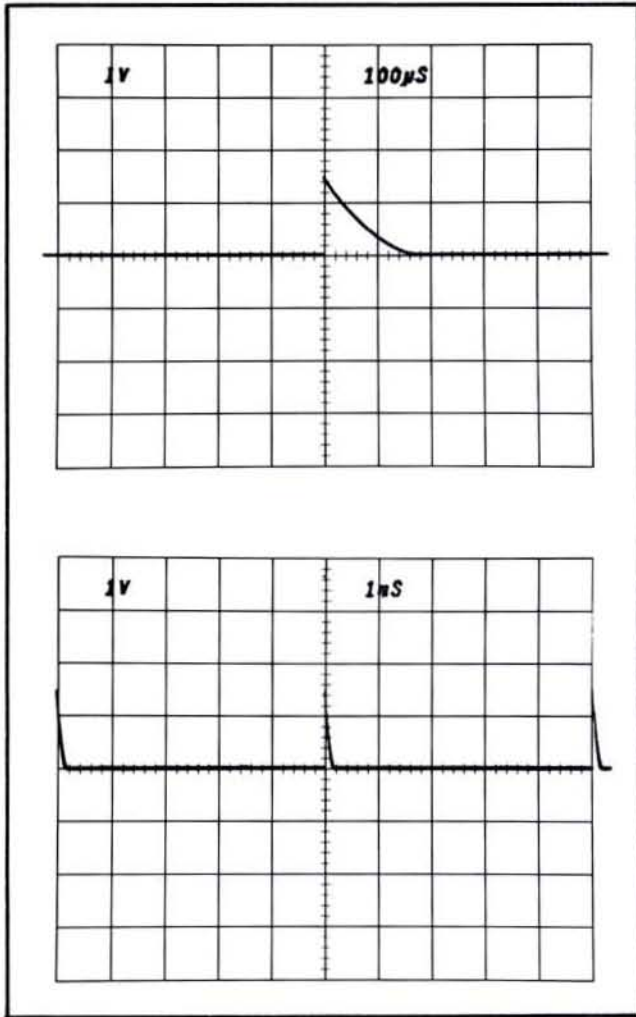

Fig. 5-8. CRT display showing correct magnifier registration. (A) MAGNIFIER set to X10 and (B) MAGNIFIER set to X1.

d. ADJUST—Mag Regis, R795, to position the middle marker to the center vertical line.

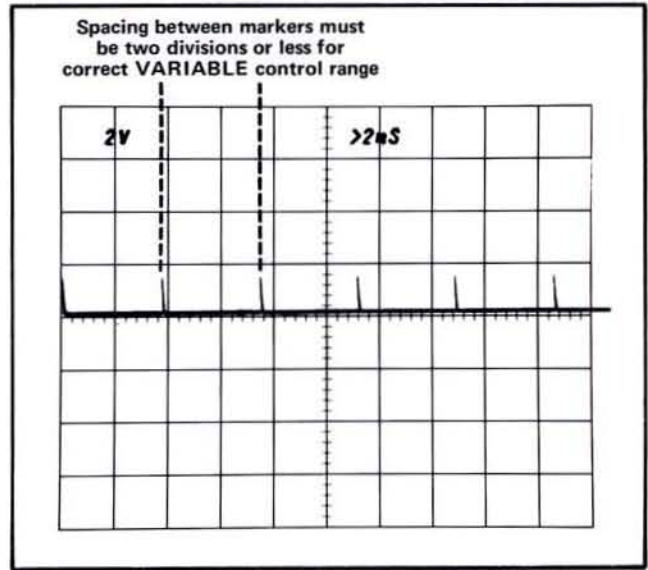

Fig. 5-9. Typical CRT display when checking VARIABLE control range.

e. Alternately switch the MAGNIFIER between X1 and X10 and repeat steps b through e until no shift occurs when switching.

16. Check Variable Time/Div

a. Reset the 7B71 TIME/DIV to 2 ms and MAGNIFIER to X1. Set the time-mark generator for 10 ms markers.

b. Press and release the VARIABLE TIME/DIV knob and turn fully counterclockwise.

c. CHECK—CRT display for a two-division maximum spacing between markers (indicates adequate range for continuously variable sweep rate between the calibrated steps; see Fig. 5-9). Return the VARIABLE TIME/DIV to the CAL IN position.

NOTES

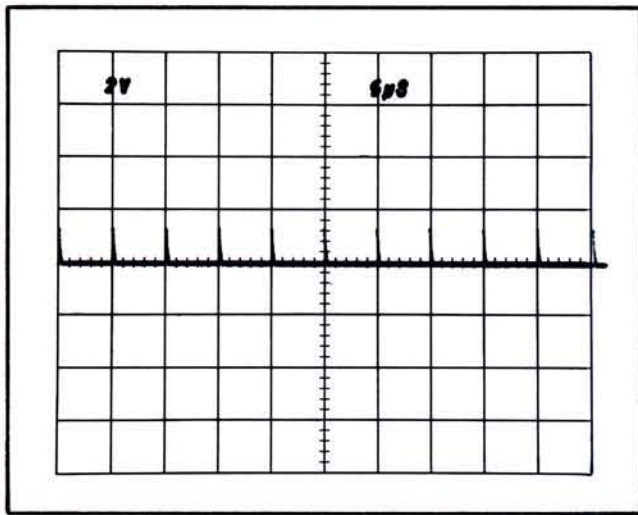
Fig. 5-10. CRT display showing correct 5 μ s timing.

17. Check/Adjust 5 μ s Timing (C530J)



- Set the time-mark generator for 5 μ s markers.
- Reset the 7B71 TIME/DIV to 5 μ s and adjust the LEVEL/SLOPE for a stable display.
- CHECK—CRT display for one marker each division between the second and tenth vertical lines. Check that sweep timing is within 0.16 division (2%) over the center eight divisions. See Fig. 5-10.

d. ADJUST—C530J for one marker each division. The second and tenth markers must coincide exactly with their respective graticule lines.

18. Check/Adjust .2 μ s Timing (C530L)



- Set the time-mark generator for .1 μ s markers.
- Set the 7B71 TIME/DIV to .2 μ s.
- CHECK—CRT display for two markers each division over the center eight divisions. Check that sweep timing is within 0.16 division (2%) over center eight divisions. See Fig. 5-11.

d. ADJUST—C530L for two markers each division. The markers at the second and tenth vertical lines must coincide exactly with their respective graticule lines (use the horizontal POSITION control as necessary to line up the display).

19. Check Sweep Timing Accuracy

- Using the control settings given in Table 5-7, check that sweep timing accuracy over the center eight divisions of the display is within the allowable limits.

TABLE 5-7

7B71 TIME/DIV	Type 184 Markers	Markers/Div	Allowable Error
.02 μ s	20 ns	1	± 0.16 div
.05 μ s	50 ns	1	
.1 μ s	.1 μ s	1	
.2 μ s	.1 μ s	2	
.5 μ s	.5 μ s	1	
1 μ s	1 μ s	1	
2 μ s	1 μ s	2	
5 μ s	5 μ s	1	
10 μ s	10 μ s	1	
20 μ s	10 μ s	2	
50 μ s	50 μ s	1	± 0.16 div
.1 ms	.1 ms	1	
.2 ms	.1 ms	2	
.5 ms	.5 ms	1	
1 ms	1 ms	1	
2 ms	1 ms	2	
5 ms	5 ms	1	
10 ms	10 ms	1	
20 ms	10 ms	2	
50 ms	50 ms	1	
.1 s	.1 s	1	± 0.24 div
.2 s	.1 s	2	
.5 s	.5 s	1	
1 s	1 s	1	
2 s	1 s	2	
5 s	5 s	1	

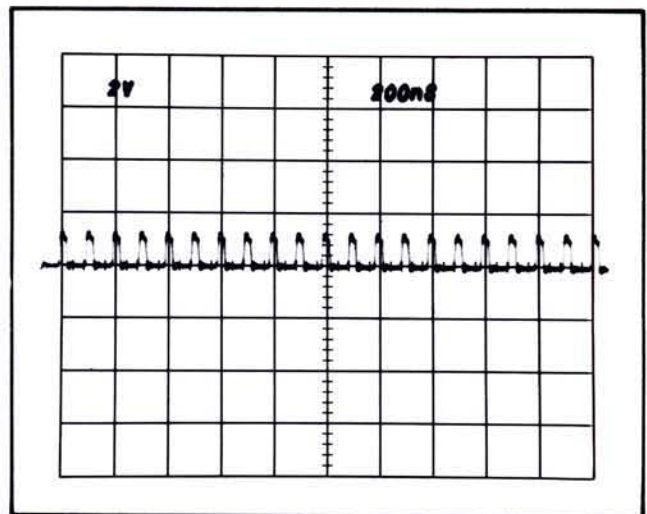
Fig. 5-11. CRT display showing correct 0.2 μ s timing.

20. Check Magnified Sweep Timing

a. CHECK—With the MAGNIFIER set to X10, use the control settings given in Table 5-8 to check timing accuracy over the center eight divisions.

TABLE 5-8

7B71 TIME/DIV	Type 184 Markers	Markers/ Div	Allowable Error	
.02 μ s	10 ns	1 cycle/5 div	0.13 div/5 div	
.05 μ s	5 ns*	1		
.1 μ s	10 ns	1		
.2 μ s	20 ns	1		
.5 μ s	50 ns	1		
1 μ s	.1 μ s	1		
2 μ s	.1 μ s	2		
5 μ s	.5 μ s	1		
10 μ s	1 μ s	1		
20 μ s	1 μ s	2		
50 μ s	5 μ s	1		
.1 ms	10 μ s	1		± 0.2 div
.2 ms	10 μ s	2		
.5 ms	50 μ s	1		
1 ms	.1 ms	1		
2 ms	.1 ms	2		
5 ms	.5 ms	1		
10 ms	1 ms	1		
20 ms	1 ms	2		
50 ms	5 ms	1		
.1 s	10 ms	1		
.2 s	10 ms	2	± 0.28 div	
.5 s	50 ms	1		
1 s	.1 s	1		
2 s	.1 s	2		
5 s	.5 s	1		

*Type 184 H. F. Selector output

b. Reset the MAGNIFIER to X1.

DELAY TIMING

Insert the Test Time-Base in the Oscilloscope right (B) horizontal compartment. Change the control settings as follows:

7B71

LEVEL/SLOPE	Centered on positive slope
TRIGGERING	
MODE	P-P AUTO
COUPLING	AC
SOURCE	INT
MAGNIFIER	X1
B DELAY MODE	B STARTS AFTER DELAY
TIME/DIV	1 ms
DELAY TIME	1.00
MULTIPLIER	

Test Time-Base (7B70)

Level/Slope	Centered on positive slope
Triggering	
Mode	Norm
Coupling	AC
Source	Int
Magnifier	X1
Display Mode	Time Base
Time/Div	10 μ s

7A16

Volts/Div 2 V

NOTES

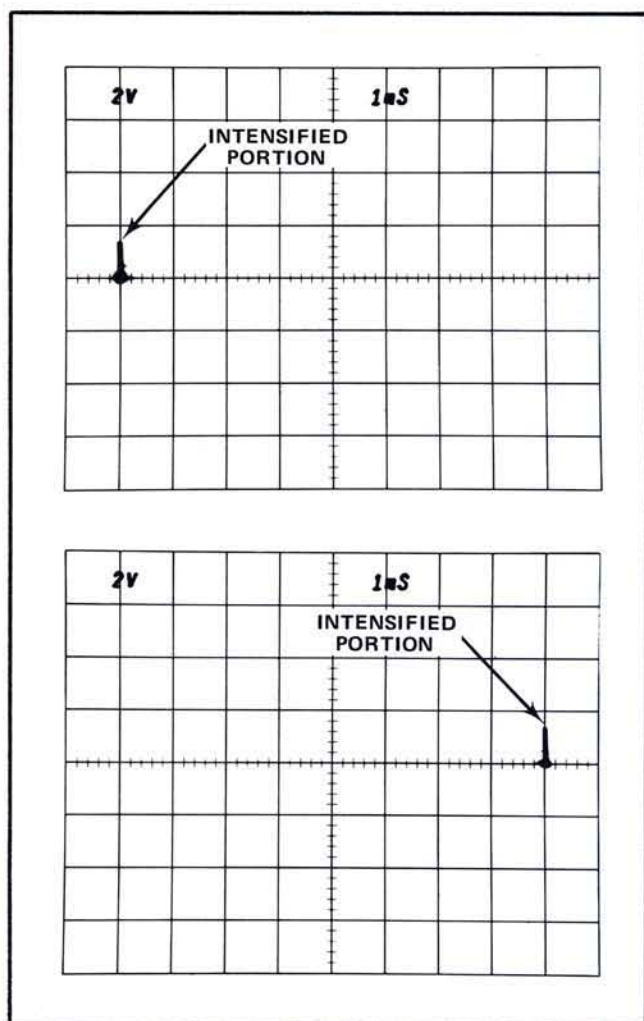

Fig. 5-12. Typical CRT display showing correct adjustment of (A) Delay Start and (B) Delay Stop.

21. Check/Adjust Delay Start (R590) and Delay Stop (R500)

a. With the 7B71 DELAY TIME MULTIPLIER fully counterclockwise, check that 0.00 is aligned with the index.

b. Set the time-mark generator for 1 ms markers. Adjust the LEVEL/SLOPE for a display triggered on the positive slope. Set the DELAY TIME MULTIPLIER to 1.00.

c. CHECK—The intensified portion of the sweep starts at the second marker. See Fig. 5-12A.

d. ADJUST—Delay Start (R590) so the intensified portion of the sweep starts at the second marker.

e. Reset the 7B71 DELAY TIME MULTIPLIER to 9.00.

f. CHECK—The intensified portion of the sweep starts at the tenth marker. See Fig. 5-12B.

g. ADJUST—Delay Stop (R500) so the intensified portion starts at the tenth marker.

h. Change the 7704 Horizontal Mode to Alt and the 7B71 DELAY TIME MULTIPLIER to 1.00.

i. CHECK—The second marker begins at the start of the delayed sweep. See Fig. 5-13.

j. ADJUST—Delay start (R590) so the second marker begins at the start of the delayed sweep.

k. Reset the DELAY TIME MULTIPLIER to 9.00.

l. CHECK—The tenth marker begins at the start of the delayed (B) sweep.

m. ADJUST—Delay Stop (R500) so the tenth marker begins at the start of the delayed (B) sweep.

NOTE

The Delay Start and Delay Stop adjustments interact. Repeat steps b through m as necessary.

22. Check Delay Time Multiplier Accuracy

a. Set the 7B71 DELAY TIME MULTIPLIER near 8.00 so the ninth marker begins at the start of the delayed sweep.

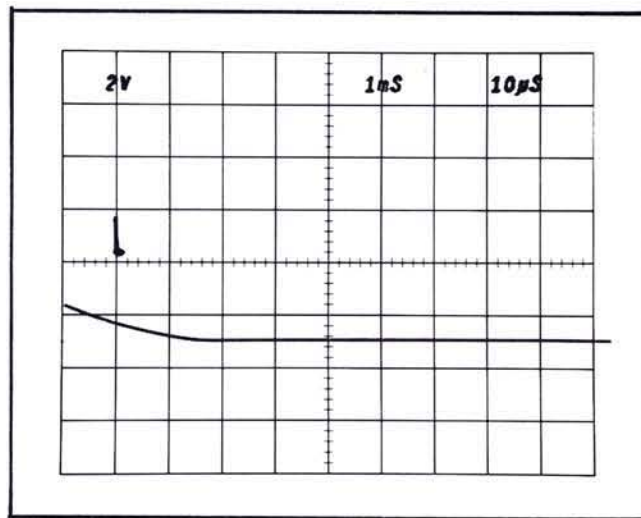

Fig. 5-13. Typical CRT display when checking delay adjustments.

Performance Check/Calibration—7B71

b. CHECK—The DELAY TIME MULTIPLIER deviation from 8.00 is within one minor division.

c. Repeat this check at each major dial setting of the DELAY TIME MULTIPLIER between 1.00 and 9.00.

23. Check Delay Time Accuracy

a. Set the 7B71 DELAY TIME MULTIPLIER near 1.00.

b. CHECK—Using the settings given in Table 5-6, check the delay time accuracy is within the given tolerance. First set the DELAY TIME MULTIPLIER near 1.00. Adjust the DELAY TIME MULTIPLIER until the second marker starts at the beginning of the delayed (B) sweep; note the dial reading. Second set the DELAY TIME MULTIPLIER near 9.00 and adjust until the tenth marker starts at the beginning of the delayed sweep; note the dial reading. Subtract the first reading from the second reading. The difference must be eight divisions + or – the allowable error given in Table 5-9.

TABLE 5-9

7B71 DELAY TIME	Test Time-Base TIME/DIV	Type 184 Markers	Allowable Error
1 μ s	.1 μ s	1 μ s	± 6 minor dial divisions
2 μ s	.1 μ s	1 μ s	
5 μ s	.5 μ s	5 μ s	
10 μ s	1 μ s	10 μ s	
20 μ s	1 μ s	10 μ s	
50 μ s	5 μ s	50 μ s	
.1 ms	10 μ s	.1 ms	
.2 ms	10 μ s	.1 ms	
.5 ms	50 μ s	.5 ms	
10 ms	1 ms	10 ms	
20 ms	1 ms	10 ms	± 10 minor dial divisions
50 ms	5 ms	50 ms	
.1 s	10 ms	.1 s	
.2 s	10 ms	.1 s	
.5 s	50 ms	.5 s	
1 s	.1 s	1 s	
2 s	.1 s	1 s	
5 s	.5 s	5 s	

24. Check Delay Time Jitter

a. Change the control settings as follows:

7A16

Volts/Div 1 V

7B71

TIME/DIV 1 ms
 DELAY TIME MULTIPLIER 10.00

Test Time Base

Time/Div .2 μ s

b. Set the time-mark generator for 1 ms markers. Position the eleventh marker near the center of the CRT display with the DELAY TIME MULTIPLIER.

c. CHECK—Jitter on the leading edge of the pulse does not exceed 1 division (1 part in 50,000 of 10 times the TIME/DIV setting). See Fig. 5-14. Disregard any slow drift.

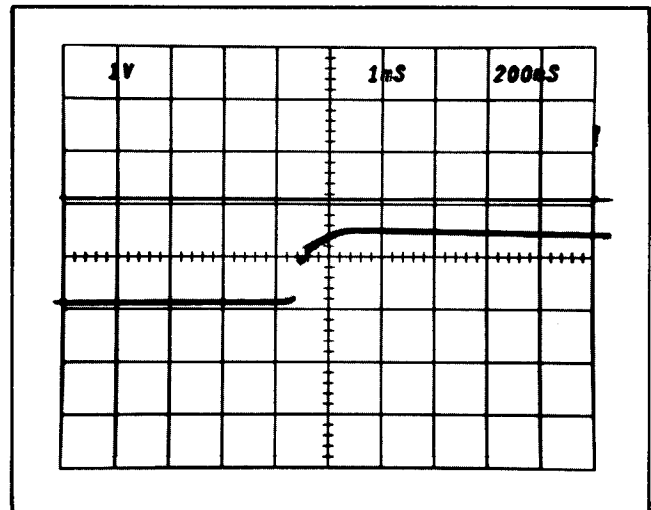

Fig. 5-14. CRT display showing delay time jitter.

NOTES

25. Check Sweep Length

- a. Set the time-mark generator for 1 ms and .1 ms markers. Reset the B DELAY MODE to INDEPENDENT, Volts/Div to 2 V and the 7704 Horizontal Mode to A.
- b. Move the eleventh 1 ms marker to the center vertical line with the horizontal POSITION control. See Fig. 5-15.
- c. CHECK—Sweep length must be between 10.5 and 13 divisions.
- d. Disconnect the time-mark generator.

7B70

Level/Slope	Centered on Positive Slope
Triggering	
Mode	Norm
Coupling	AC
Source	Int
Display Mode	Time Base
Magnifier	X1
Time/Div	5 μ s

7704

Vertical Mode	Left
Horizontal Mode	B
A Trigger Source	Right Vert
B Trigger Source	Left Vert

26. Check Sweep Holdoff Time

- a. Move the 7A16 to the left vertical compartment. Change the control settings as follows:

- b. Connect a 10X probe from the 7A16 to TP 566 on the 7B71 Sweep Generator Board.

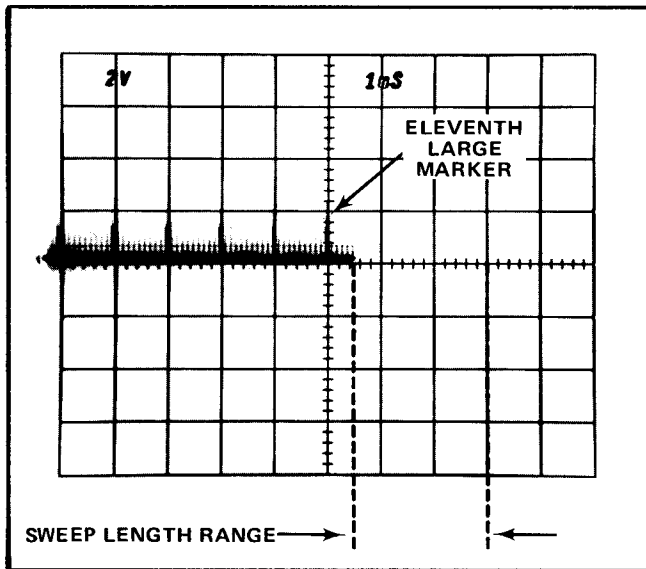

- c. CHECK—The holdoff time is 3.5 μ s or less (see Fig. 5-16).

- d. Check the holdoff time at each TIME/DIV setting for the following performance limits:

5 s/DIV to 5 μ s/DIV	1.5 times the TIME/DIV setting or less
2 μ s/DIV to .02 μ s/DIV	3.5 μ s or less

This completes the calibration of the 7B71 Delaying Time Base.

Fig. 5-15. CRT display when checking sweep length.

	7A16
Volts/Div	.2 V
	7B71
TRIGGERING	
MODE	P-P AUTO
COUPLING	AC
SOURCE	INT
B DELAY MODE	INDEPENDENT
TIME/DIV	2 μ s
MAGNIFIER	X1

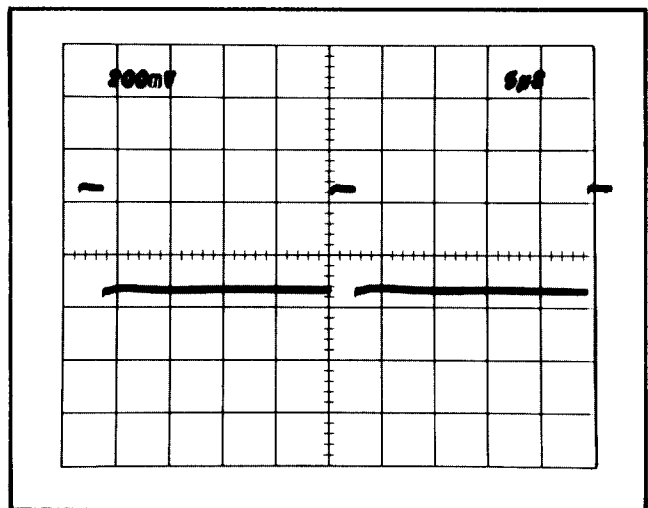

Fig. 5-16. CRT display when checking sweep holdoff time.

PARTS LIST ABBREVIATIONS

BHB	binding head brass	int	internal
BHS	binding head steel	lg	length or long
cap.	capacitor	met.	metal
cer	ceramic	mtg hdw	mounting hardware
comp	composition	OD	outside diameter
conn	connector	OHB	oval head brass
CRT	cathode-ray tube	OHS	oval head steel
csk	countersunk	P/O	part of
DE	double end	PHB	pan head brass
dia	diameter	PHS	pan head steel
div	division	plstc	plastic
elect.	electrolytic	PMC	paper, metal cased
EMC	electrolytic, metal cased	poly	polystyrene
EMT	electrolytic, metal tubular	prec	precision
ext	external	PT	paper, tubular
F & I	focus and intensity	PTM	paper or plastic, tubular, molded
FHB	flat head brass	RHB	round head brass
FHS	flat head steel	RHS	round head steel
Fil HB	fillister head brass	SE	single end
Fil HS	fillister head steel	SN or S/N	serial number
h	height or high	S or SW	switch
hex.	hexagonal	TC	temperature compensated
HHB	hex head brass	THB	truss head brass
HHS	hex head steel	thk	thick
HSB	hex socket brass	THS	truss head steel
HSS	hex socket steel	tub.	tubular
ID	inside diameter	var	variable
inc	incandescent	w	wide or width
		WW	wire-wound

PARTS ORDERING INFORMATION

Replacement parts are available from or through your local Tektronix, Inc. Field Office or representative.

Changes to Tektronix instruments are sometimes made to accommodate improved components as they become available, and to give you the benefit of the latest circuit improvements developed in our engineering department. It is therefore important, when ordering parts, to include the following information in your order: Part number, instrument type or number, serial or model number, and modification number if applicable.

If a part you have ordered has been replaced with a new or improved part, your local Tektronix, Inc. Field Office or representative will contact you concerning any change in part number.

SPECIAL NOTES AND SYMBOLS

- | | |
|-----------------|---|
| ×000 | Part first added at this serial number |
| 00× | Part removed after this serial number |
| *000-0000-00 | Asterisk preceding Tektronix Part Number indicates manufactured by or for Tektronix, Inc., or reworked or checked components. |
| Use 000-0000-00 | Part number indicated is direct replacement. |

INDEX OF ELECTRICAL PARTS LIST

Title	Page No.
CHASSIS	6-1
EXTERNAL INPUT Circuit Board Assembly	6-2
TRIGGER Circuit Board Assembly	6-3
INTERFACE Circuit Board Assembly	6-10
TRIGGER MODE Circuit Board Assembly	6-12
COUPLING Circuit Board Assembly	6-13
TIME BASE Circuit Board Assembly	6-13
B DELAY MODE Circuit Board Assembly	6-21
SOURCE Circuit Board Assembly	6-21
MAGNIFIER Circuit Board Assembly	6-22

SECTION 6

ELECTRICAL PARTS LIST

Values are fixed unless marked Variable.

Ckt. No.	Tektronix Part No.	Serial/Model No. Eff	No. Disc	Description
----------	--------------------	----------------------	----------	-------------

CHASSIS

Bulb

DS347	*150-0048-01			Incandescent #683, selected
-------	--------------	--	--	-----------------------------

Capacitors

Tolerance $\pm 20\%$ unless otherwise indicated.

C530A } C530B } C530E } C530F } C530H }	*295-0122-00			10 μF 1 μF 0.1 μF 0.01 μF 0.001 μF	Timing capacitor assembly
---	--------------	--	--	---	---------------------------

Connector

J1	131-0955-00			Receptacle, electrical BNC
----	-------------	--	--	----------------------------

Resistors

Resistors are fixed, composition, $\pm 10\%$ unless otherwise indicated.

R146A ¹ } R146B ¹ }	*311-0972-00			10 k Ω 10 k Ω Var	
R505	311-0946-00			50 k Ω , Var	
R740	311-0486-00			500 Ω , Var	

R744A } R744B }	*311-0965-00	B010100	B109999	10 k Ω 10 k Ω Var	
R744A } R744B }	311-1162-00	B110000		10 k Ω 10 k Ω Var	

Switch

Wired or Unwired

S146²

¹Furnished as a unit with S146.

²Furnished as a unit with R146A,B.

EXTERNAL INPUT Circuit Board Assembly

Ckt. No.	Tektronix Part No.	Serial/Model No. Eff	Disc	Description
----------	--------------------	----------------------	------	-------------

*670-1144-00

Complete Board

Capacitors

Tolerance $\pm 20\%$ unless otherwise indicated.

C1	281-0592-00		4.7 pF	Cer	200 V	± 0.5 pF
C2	283-0068-00		0.01 μ F	Cer	500 V	
C3	283-0080-00		0.022 μ F	Cer	25 V	+80% -20%
C5	281-0718-00		15.8 pF	Cer	500 V	1%
C6	283-0080-00		0.022 μ F	Cer	25 V	+80% -20%
C10	281-0632-00		35 pF	Cer	500 V	1%
C12	281-0653-00		3.3 pF	Cer	20 V	± 1 pF
C13	281-0592-00		4.7 pF	Cer	200 V	± 0.5 pF
C15	281-0610-00		2.2 pF	Cer	200 V	± 0.1 pF
C31	283-0156-00		1000 pF	Cer	200 V	10%
C39	283-0156-00		1000 pF	Cer	200 V	10%
C55	283-0080-00		0.022 μ F	Cer	25 V	+80% -20%
C57	283-0080-00		0.022 μ F	Cer	25 V	+80% -20%

Semiconductor Device, Diodes

CR15	152-0246-00	Silicon	Low leakage 250 mW, 40 V
VR25	152-0127-00	Zener	1N755A 400 mW, 7.5 V, 5%

Relays

K3	*148-0035-00	Armature, spdt, 15 V DC
K6	*148-0034-00	Armature, dpdt, 15 V DC

Transistors

Q20A, B	151-1009-00	Silicon	Dual, FET
Q30	151-0221-00	Silicon	2N4258
Q37	151-0221-00	Silicon	2N4258

EXTERNAL INPUT Circuit Board Assembly (cont)

Ckt. No.	Tektronix Part No.	Serial/Model No. Eff	Disc	Description		
Resistors						
Resistors are fixed, composition, $\pm 10\%$ unless otherwise indicated.						
R1	317-0270-00		27 Ω	$\frac{1}{8}$ W		5%
R2	317-0101-00		100 Ω	$\frac{1}{8}$ W		5%
R5	323-0452-00		499 k Ω	$\frac{1}{2}$ W	Prec	1%
R7	321-0452-00		499 k Ω	$\frac{1}{8}$ W	Prec	1%
R8	321-0448-00		453 k Ω	$\frac{1}{8}$ W	Prec	1%
R10	317-0390-00		39 Ω	$\frac{1}{8}$ W		5%
R11	321-0361-00		56.2 k Ω	$\frac{1}{8}$ W	Prec	1%
R12	317-0270-00		27 Ω	$\frac{1}{8}$ W		5%
R15	317-0100-00		10 Ω	$\frac{1}{8}$ W		5%
R16	317-0270-00		27 Ω	$\frac{1}{8}$ W		5%
R20	317-0101-00		100 Ω	$\frac{1}{8}$ W		5%
R22	317-0392-00		3.9 k Ω	$\frac{1}{8}$ W		5%
R23	317-0391-00		390 Ω	$\frac{1}{8}$ W		5%
R25	311-0634-00		500 Ω , Var			
R26	317-0392-00		3.9 k Ω	$\frac{1}{8}$ W		5%
R27	317-0270-00		27 Ω	$\frac{1}{8}$ W		5%
R28	317-0101-00		100 Ω	$\frac{1}{8}$ W		5%
R31	317-0331-00		330 Ω	$\frac{1}{8}$ W		5%
R33	321-0185-00		825 Ω	$\frac{1}{8}$ W	Prec	1%
R34	317-0360-00		36 Ω	$\frac{1}{8}$ W		5%
R36	321-0174-00		634 Ω	$\frac{1}{8}$ W	Prec	1%
R37	311-0634-00		500 Ω , Var			
R39	317-0331-00		330 Ω	$\frac{1}{8}$ W		5%

TRIGGER Circuit Board Assembly

*670-1141-00	B010100	B019999	Complete Board
*670-1141-01	B020000	B029999	Complete Board
*670-1141-02	B030000	B129999	Complete Board
*670-1141-03	B130000		Complete Board

Capacitors

Tolerance $\pm 20\%$ unless otherwise indicated.

C48	283-0000-00	0.001 μ F	Cer	500 V	
C100	281-0544-00	5.6 pF	Cer	500 V	10%
C104	281-0544-00	5.6 pF	Cer	500 V	10%
C106	283-0000-00	0.001 μ F	Cer	500 V	
C108	283-0000-00	0.001 μ F	Cer	500 V	

TRIGGER Circuit Board Assembly (cont)

Ckt. No.	Tektronix Part No.	Serial/Model No. Eff	Disc	Description		
Capacitors (cont)						
C129	290-0134-00			22 μ F	Elect.	15 V
C138	283-0079-00			0.01 μ F	Cer	250 V
C141	281-0593-00			3.9 pF	Cer	500 V
C147	281-0593-00			3.9 pF	Cer	500 V
C150	281-0629-00			33 pF	Cer	600 V
						10%
						5%
C156	281-0629-00			33 pF	Cer	600 V
C170	281-0534-00			3.3 pF	Cer	500 V
C171	281-0534-00			3.3 pF	Cer	500 V
C173	283-0000-00			0.001 μ F	Cer	500 V
C176	281-0509-00	B010100	B019999	15 pF	Cer	500 V
C176	281-0552-00	B020000		25 pF	Cer	500 V
						10%
C178	283-0002-00			0.01 μ F	Cer	500 V
C179	283-0000-00			0.001 μ F	Cer	500 V
C198	283-0059-00			1 μ F	Cer	25 V
C199	283-0059-00			1 μ F	Cer	25 V
C200	281-0511-00			22 pF	Cer	500 V
						+80% - 20%
						+80% - 20%
						10%
C201	283-0059-00			1 μ F	Cer	25 V
C203	281-0511-00			22 pF	Cer	500 V
C204	283-0059-00			1 μ F	Cer	25 V
C207	283-0080-00			0.0022 μ F	Cer	25 V
C209	290-0267-00			1 μ F	Elect.	35 V
						+80% - 20%
						10%
						+80% - 20%
						+80% - 20%
C210	281-0523-00			100 pF	Cer	350 V
C212	281-0523-00			100 pF	Cer	350 V
C248	283-0010-00			0.05 μ F	Cer	50 V
C255	283-0010-00			0.05 μ F	Cer	50 V
C268	281-0549-00	B010100	B019999	68 pF	Cer	500 V
C268	283-0604-00	B020000		304 pF	Mica	300 V
						10%
						2%
C275	281-0523-00			100 pF	Cer	350 V
C282	283-0002-00			0.01 μ F	Cer	500 V
C303	283-0159-00			18 pF	Cer	50 V
C312	283-0080-00			0.022 μ F	Cer	25 V
C315	283-0156-00			0.001 μ F	Cer	200 V
						5%
						+80% - 20%
						10%
C319	283-0080-00			0.022 μ F	Cer	25 V
C320	283-0103-00	B010100	B059999	180 pF	Cer	500 V
C320	281-0662-00	B060000		10 pF	Cer	500 V
C324	283-0175-00			10 pF	Cer	200 V
C331	283-0000-00			0.001 μ F	Cer	500 V
						+80% - 20%
						5%
						± 0.5 pF
						5%
C332	283-0159-00			18 pF	Cer	50 V
C336	283-0080-00			0.022 μ F	Cer	25 V
C339	290-0305-01			3 μ F	Elect.	150 V
C363	283-0059-00			1 μ F	Cer	25 V
C378	290-0136-00			2.2 μ F	Elect.	20 V
						+80% - 20%
						10%

TRIGGER Circuit Board Assembly (cont)

Ckt. No.	Tektronix Part No.	Serial/Model No. Eff	Disc	Description
Semiconductor Device, Diodes				
CR148	*152-0153-00		Silicon	Tek Spec
CR149	*152-0153-00		Silicon	Tek Spec
CR181	*152-0322-00		Silicon	Tek Spec
CR182	*152-0322-00		Silicon	Tek Spec
CR205	*152-0322-00		Silicon	Tek Spec
CR210	*152-0322-00		Silicon	Tek Spec
CR212	*152-0322-00		Silicon	Tek Spec
VR304	152-0154-00		Tunnel	TD253 10 mA
CR319	*152-0322-00		Silicon	Tek Spec
CR320	*152-0185-00		Silicon	Replaceable by 1N4152
VR322	*152-0125-00		Tunnel	TD3A 4.7 mA Tek Spec
CR331	*152-0075-00		Germanium	Tek Spec
CR342	*152-0185-00		Silicon	Replaceable by 1N4152
CR355	*152-0185-00		Silicon	Replaceable by 1N4152
CR357	*152-0185-00		Silicon	Replaceable by 1N4152
VR358	152-0125-00		Tunnel	TD3A 4.7 mA Tek Spec
Relays				
K44	*148-0034-00		Armature, dpdt, 15 V	DC
K48	*148-0034-00		Armature, dpdt, 15 V	DC
K138	*148-0034-00		Armature, dpdt, 15 V	DC
Inductors				
L100	*108-0577-00		30 nH	
L104	*108-0577-00		30 nH	
L140	*108-0581-00		100 nH	
L141	*108-0369-00		0.12 μ H	
L146	*108-0581-00		100 nH	
L147	*108-0369-00		0.12 μ H	
L148	*108-0578-00		45 nH	
L149	*108-0578-00		45 nH	
L170	*108-0579-00		120 nH	
L171	*108-0579-00		120 nH	
L304	*108-0580-00		90 nH	
L310	108-0317-00		15 μ H	
L318	*108-0370-00		0.14 μ H	

TRIGGER Circuit Board Assembly (cont)

Ckt. No.	Tektronix Part No.	Serial/Model No. Eff	No. Disc		Description
Transistors					
Q107	151-0220-00			Silicon	2N4122
Q108	151-0220-00			Silicon	2N4122
Q110	151-0220-00			Silicon	2N4122
Q116	151-0220-00			Silicon	2N4122
Q120	151-0224-00			Silicon	2N3692
Q126	151-0224-00			Silicon	2N3692
Q131	151-0220-00			Silicon	2N4122
Q134	151-0220-00			Silicon	2N4122
Q150	*151-0198-00	B010100	B129999	Silicon	Replaceable by MPS 918
Q150	*151-0269-00	B130000		Silicon	Selected from SE 3005
Q156	*151-0198-00	B010100	B129999	Silicon	Replaceable by MPS 918
Q156	*151-0269-00	B130000		Silicon	Selected from SE 3005
Q158	*151-0198-00			Silicon	Replaceable by MPS 918
Q159	*151-0198-00			Silicon	Replaceable by MPS 918
Q161	151-0188-00			Silicon	2N3906
Q168	*151-0198-00			Silicon	Replaceable by MPS 918
Q169	*151-0198-00			Silicon	Replaceable by MPS 918
Q170	*151-0198-00			Silicon	Replaceable by MPS 918
Q171	*151-0198-00			Silicon	Replaceable by MPS 918
Q181	151-0223-00			Silicon	2N4275
Q182	151-0223-00			Silicon	2N4275
Q220	151-0221-00			Silicon	2N4258
Q221	151-0221-00			Silicon	2N4258
Q224	151-0223-00	B010100	B039999	Silicon	2N4275
Q224	*151-0190-01	B040000		Silicon	Tek Spec
Q235	151-0221-00			Silicon	2N4258
Q236	151-0221-00			Silicon	2N4258
Q238	151-0223-00	B010100	B039999	Silicon	2N4275
Q238	*151-0190-01	B040000		Silicon	Tek Spec
Q248	151-1006-00			Silicon	FET
Q255	151-1006-00			Silicon	FET
Q309	151-0221-00	B010100	B109999	Silicon	2N4258
Q309	151-0220-00	B110000		Silicon	2N4122
Q317	151-0221-00	B010100	B109999	Silicon	2N4258
Q317	151-0220-00	B110000		Silicon	2N4122
Q326	151-0224-00	B010100	B109999	Silicon	2N3692
Q326	151-0190-02	B110000		Silicon	2N3904
Q328	151-0224-00	B010100	B109999	Silicon	2N3692
Q328	151-0190-02	B110000		Silicon	2N3904
Q331	151-0221-00			Silicon	2N4258
Q338	*151-0190-01			Silicon	Tek Spec
Q339	151-0220-00			Silicon	2N4122
Q346	151-0220-00			Silicon	2N4122
Q348	*151-0192-00			Silicon	Replaceable by MPS 6521
Q350	151-0220-00			Silicon	2N4122
Q360	151-0223-00			Silicon	2N4275
Q368	151-0223-00			Silicon	2N4275
Q377	151-0223-00			Silicon	2N4275

TRIGGER Circuit Board Assembly (cont)

Ckt. No.	Tektronix Part No.	Serial/Model No. Eff	Disc	Description		
Resistors						
Resistors are fixed, composition, $\pm 10\%$ unless otherwise indicated.						
R40	322-0215-00		1.69 k Ω	1/4 W	Prec	1%
R42	322-0215-00		1.69 k Ω	1/4 W	Prec	1%
R47	321-0068-00		49.9 Ω	1/8 W	Prec	1%
R49	321-0068-00		49.9 Ω	1/8 W	Prec	1%
R100	317-0560-00		56 Ω	1/8 W		5%
R101	321-0072-00		54.9 Ω	1/8 W	Prec	1%
R103	321-0072-00		54.9 Ω	1/8 W	Prec	1%
R104	317-0560-00		56 Ω	1/8 W		5%
R106	317-0470-00		47 Ω	1/8 W		5%
R107	321-0046-00		29.4 Ω	1/8 W	Prec	1%
R108	317-0470-00		47 Ω	1/8 W		5%
R110	315-0820-00		82 Ω	1/4 W		5%
R111	321-0193-00		1 k Ω	1/8 W	Prec	1%
R112	323-0161-00		464 Ω	1/2 W	Prec	1%
R113	321-0047-00		30.1 Ω	1/8 W	Prec	1%
R114	323-0161-00		464 Ω	1/2 W	Prec	1%
R116	315-0820-00		82 Ω	1/4 W		5%
R117	321-0193-00		1 k Ω	1/8 W	Prec	1%
R119	321-0288-00		9.76 k Ω	1/8 W	Prec	1%
R120	321-0291-00		10.5 k Ω	1/8 W	Prec	1%
R121	311-0732-00		1 k Ω , Var			
R122	321-0282-00		8.45 k Ω	1/8 W	Prec	1%
R124	315-0102-00		1 k Ω	1/4 W		5%
R126	321-0288-00		9.76 k Ω	1/8 W	Prec	1%
R127	321-0293-00		11 k Ω	1/8 W	Prec	1%
R128	321-0285-00		9.09 k Ω	1/8 W	Prec	1%
R129	317-0102-00		1 k Ω	1/8 W		5%
R130	315-0152-00		1.5 k Ω	1/4 W		5%
R132	317-0122-00		1.2 k Ω	1/8 W		5%
R133	317-0122-00		1.2 k Ω	1/8 W		5%
R135	315-0361-00		360 Ω	1/4 W		5%
R136	315-0102-00		1 k Ω	1/4 W		5%
R141	323-0151-00		365 Ω	1/2 W	Prec	1%
R142	317-0511-00		510 Ω	1/8 W		5%
R143	321-0115-00		154 Ω	1/8 W	Prec	1%
R144	321-0115-00		154 Ω	1/8 W	Prec	1%
R145	317-0511-00		510 Ω	1/8 W		5%
R147	323-0151-00		365 Ω	1/2 W	Prec	1%
R148	315-0223-00		22 k Ω	1/4 W		5%
R149	315-0223-00		22 k Ω	1/4 W		5%

TRIGGER Circuit Board Assembly (cont)

Ckt. No.	Tektronix Part No.	Serial/Model No. Eff	Disc	Description
Resistors (cont)				
R150	317-0560-00			56 Ω 1/8 W 5%
R152	321-0045-00			28.7 Ω 1/8 W Prec 1%
R153	323-0153-00			383 Ω 1/2 W Prec 1%
R154	321-0045-00			28.7 Ω 1/8 W Prec 1%
R155	311-0633-00			5 kΩ, Var
R156	317-0560-00			56 Ω 1/8 W 5%
R158	315-0562-00			5.6 kΩ 1/4 W 5%
R159	315-0122-00			1.2 kΩ 1/4 W 5%
R160	315-0392-00			3.9 kΩ 1/4 W 5%
R163	317-0392-00			3.9 kΩ 1/8 W 5%
R165	315-0432-00			4.3 kΩ 1/4 W 5%
R166	315-0112-00			1.1 kΩ 1/4 W 5%
R167	315-0562-00			5.6 kΩ 1/4 W 5%
R170	321-0096-00			97.6 Ω 1/8 W Prec 1%
R171	321-0096-00			97.6 Ω 1/8 W Prec 1%
R173	317-0201-00			200 Ω 1/8 W 5%
R175	315-0100-00	B010100	B019999	10 Ω 1/4 W 5%
R175	307-0115-00	B020000		7.5 Ω 1/4 W 5%
R176	303-0432-00			4.3 kΩ 1 W 5%
R177	315-0100-00	B010100	B019999	10 Ω 1/4 W 5%
R177	307-0115-00	B020000		7.5 Ω 1/4 W 5%
R179	317-0201-00			200 Ω 1/8 W 5%
R181	315-0113-00			11 kΩ 1/4 W 5%
R182	315-0332-00			3.3 kΩ 1/4 W 5%
R201	315-0512-00			5.1 kΩ 1/4 W 5%
R203	315-0512-00			5.1 kΩ 1/4 W 5%
R205	315-0104-00			100 kΩ 1/4 W 5%
R209	315-0512-00			5.1 kΩ 1/4 W 5%
R210	317-0221-00			220 Ω 1/8 W 5%
R212	317-0221-00			220 Ω 1/8 W 5%
R214	315-0155-00			1.5 MΩ 1/4 W 5%
R215	317-0472-00			4.7 kΩ 1/8 W 5%
R217	317-0124-00			120 kΩ 1/8 W 5%
R219	315-0392-00	B010100	B039999	3.9 kΩ 1/4 W 5%
R219	315-0153-00	B040000		15 kΩ 1/4 W 5%
R221	317-0162-00			1.6 kΩ 1/8 W 5%
R225	307-0112-00			4.3 Ω 1/4 W 5%
R230	315-0155-00			1.5 MΩ 1/4 W 5%
R231	317-0472-00			4.7 kΩ 1/8 W 5%
R233	317-0124-00			120 kΩ 1/8 W 5%
R234	315-0392-00	B010100	B039999	3.9 kΩ 1/4 W 5%
R234	315-0153-00	B040000		15 kΩ 1/4 W 5%
R235	317-0162-00			1.6 kΩ 1/8 W 5%
R239	307-0112-00			4.3 Ω 1/4 W 5%
R241	315-0106-00			10 MΩ 1/4 W 5%
R243	315-0474-00			470 kΩ 1/4 W 5%
R244	315-0623-00			62 kΩ 1/4 W 5%
R246	315-0106-00			10 MΩ 1/4 W 5%
R248	317-0510-00			51 Ω 1/8 W 5%

TRIGGER Circuit Board Assembly (cont)

Ckt. No.	Tektronix Part No.	Serial/Model No. Eff	Disc	Description
Resistors (cont)				
R250	321-0268-00			6.04 k Ω 1/8 W Prec 1%
R251	311-0884-00			100 Ω , Var
R252	321-0222-00			2 k Ω 1/8 W Prec 1%
R253	321-0260-00			4.99 k Ω 1/8 W Prec 1%
R255	317-0510-00			51 Ω 1/8 W 5%
R257	321-0268-00			6.04 k Ω 1/8 W Prec 1%
R258	311-0884-00			100 Ω , Var
R259	321-0222-00			2 k Ω 1/8 W Prec 1%
R260	321-0260-00			4.99 k Ω 1/8 W Prec 1%
R265	317-0102-00			1 k Ω 1/8 W 5%
R275	321-0289-00			10 k Ω 1/8 W Prec 1%
R282	315-0102-00			1 k Ω 1/4 W 5%
R284	315-0513-00	B010100	B029999	51 k Ω 1/4 W 5%
R284	315-0123-00	B030000		12 k Ω 1/4 W 5%
R300	317-0620-00			62 Ω 1/8 W 5%
R301	321-0158-00			432 Ω 1/8 W Prec 1%
R302	321-0135-00			249 Ω 1/8 W Prec 1%
R303	317-0510-00	B010100	B059999	51 Ω 1/8 W 5%
R303	317-0510-00	B060000		51 Ω (nominal value) Selected
R306	317-0620-00			62 Ω 1/8 W 5%
R307	321-0177-00			681 Ω 1/8 W Prec 1%
R310	317-0471-00			470 Ω 1/8 W 5%
R313	315-0821-00			820 Ω 1/4 W 5%
R315	317-0200-00			20 Ω 1/8 W 5%
R318	317-0151-00			150 Ω 1/8 W 5%
R319	317-0752-00			7.5 k Ω 1/8 W 5%
R320	317-0751-00			750 Ω 1/8 W 5%
R322	317-0391-00			390 Ω 1/8 W 5%
R324	317-0301-00			300 Ω 1/8 W 5%
R326	317-0200-00			20 Ω 1/8 W 5%
R327	317-0242-00			2.4 k Ω 1/8 W 5%
R328	315-0152-00			1.5 k Ω 1/4 W 5%
R329	317-0200-00			20 Ω 1/8 W 5%
R331	315-0152-00			1.5 k Ω 1/4 W 5%
R333	317-0102-00			1 k Ω 1/8 W 5%
R334	317-0183-00			18 k Ω 1/8 W 5%
R335	317-0202-00			2 k Ω 1/8 W 5%
R336	317-0102-00			1 k Ω 1/8 W 5%
R339	317-0471-00			470 Ω 1/8 W 5%
R340	317-0102-00			1 k Ω 1/8 W 5%
R341	317-0303-00			30 k Ω 1/8 W 5%
R342	317-0102-00			1 k Ω 1/8 W 5%

TRIGGER Circuit Board Assembly (cont)

Ckt. No.	Tektronix Part No.	Serial/Model No. Eff	Disc	Description		
Resistors (cont)						
R343	315-0154-00		150 kΩ	1/4 W		5%
R344	315-0223-00		22 kΩ	1/4 W		5%
R346	315-0302-00		3 kΩ	1/4 W		5%
R353	321-0321-00		21.5 kΩ	1/8 W	Prec	1%
R354	321-0285-00		9.09 kΩ	1/8 W	Prec	1%
R356	321-0177-00		681 Ω	1/8 W	Prec	1%
R357	321-0239-00		3.01 kΩ	1/8 W	Prec	1%
R361	321-0126-00		200 Ω	1/8 W	Prec	1%
R363	317-0036-00		3.6 Ω	1/8 W		5%
R364	321-0144-00		309 Ω	1/8 W	Prec	1%
R366	321-0122-00		182 Ω	1/8 W	Prec	1%
R367	321-0030-00		20 Ω	1/8 W	Prec	1%
R370	323-0192-00		976 Ω	1/2 W	Prec	1%
R374	317-0101-00		100 Ω	1/8 W		5%
R377	315-0391-00		390 Ω	1/4 W		5%
R379	315-0182-00		1.8 kΩ	1/4 W		5%
R380	317-0100-00		10 Ω	1/8 W		5%

Integrated Circuits

U260	156-0049-00		Oper. Ampl.	Replaceable by Fairchild μ A741C		
U267	156-0049-00		Oper. Ampl.	Replaceable by Fairchild μ A741C		

INTERFACE Circuit Board Assembly

*670-1142-00

Complete Board

Capacitors

Tolerance $\pm 20\%$ unless otherwise indicated.

C280	290-0267-00			1 μ F	Elect.	35 V	
C530P	281-0523-00			100 pF	Cer	350 V	
C530R	281-0536-00			1000 pF	Cer	500 V	10%
C530S	281-0523-00	B010100	B049999	100 pF	Cer	350 V	
C5305	283-0599-00	B050000		98 pF	Mica	500 V	5%
C584	290-0136-00			2.2 μ F	Elect.	20 V	

INTERFACE Circuit Board Assembly (cont)

Ckt. No.	Tektronix Part No.	Serial/Model No. Eff	Disc	Description
Semiconductor Device, Diodes				
CR44	*152-0185-00		Silicon	Replaceable by 1N4152
CR461	*152-0185-00		Silicon	Replaceable by 1N4152
CR531	*152-0185-00		Silicon	Replaceable by 1N4152
CR702	*152-0075-00		Germanium	Tek Spec
CR704	*152-0185-00		Silicon	Replaceable by 1N4152
CR705	*152-0185-00		Silicon	Replaceable by 1N4152
CR711	*152-0185-00		Silicon	Replaceable by 1N4152
CR712	*152-0185-00		Silicon	Replaceable by 1N4152
CR721	*152-0185-00		Silicon	Replaceable by 1N4152
CR722	*152-0185-00		Silicon	Replaceable by 1N4152
Switches				
Wired or Unwired				
S530 ³	*670-1142-00		Cam	TIME/DIV
S531 ⁴				CAL IN
Resistors				
Resistors are fixed, composition, $\pm 10\%$ unless otherwise indicated.				
R178	301-0100-00		10 Ω	$\frac{1}{2}$ W 5%
R280	315-0513-00		51 k Ω	$\frac{1}{4}$ W 5%
R312	303-0392-00		3.9 k Ω	1 W 5%
R347	315-0200-00		20 Ω	$\frac{1}{4}$ W 5%
R460	315-0472-00		4.7 k Ω	$\frac{1}{4}$ W 5%
R461	315-0752-00		7.5 k Ω	$\frac{1}{4}$ W 5%
R530A	323-0568-08		8.06 M Ω	$\frac{1}{2}$ W Prec 1%
R530B	323-0557-08		6.19 M Ω	$\frac{1}{2}$ W Prec 1%
R530C	323-0546-08		4.75 M Ω	$\frac{1}{2}$ W Prec 1%
R530D	323-0546-08		4.75 M Ω	$\frac{1}{2}$ W Prec 1%
R530F	323-0767-07		1.425 M Ω	$\frac{1}{2}$ W Prec 1/10%
R530H	323-0450-07		475 k Ω	$\frac{1}{2}$ W Prec 1/10%
R530J	323-0450-07		475 k Ω	$\frac{1}{2}$ W Prec 1/10%
R530K	323-0774-07		118.7 k Ω	$\frac{1}{2}$ W Prec 1/10%
R530L	323-0354-07		47.5 k Ω	$\frac{1}{2}$ W Prec 1/10%
R530M	321-0267-00		5.9 k Ω	$\frac{1}{8}$ W Prec 1%
R530N	323-0775-07		71.25 k Ω	$\frac{1}{2}$ W Prec 1/10%
R530P	315-0330-00		33 Ω	$\frac{1}{4}$ W 5%
R530R	315-0220-00		22 Ω	$\frac{1}{4}$ W 5%
R530S	315-0390-00		39 Ω	$\frac{1}{4}$ W 5%
R531	311-0959-00		10 k Ω , Var	
R584	315-0101-00		100 Ω	$\frac{1}{4}$ W 5%
R701	315-0154-00		150 k Ω	$\frac{1}{4}$ W 5%
R702	315-0133-00		13 k Ω	$\frac{1}{4}$ W 5%
R704	315-0154-00		150 k Ω	$\frac{1}{4}$ W 5%
R705	321-0344-00		37.4 k Ω	$\frac{1}{8}$ W Prec 1%

³See Mechanical Parts List for replacement parts.⁴Furnished as a unit with S530.

INTERFACE Circuit Board Assembly (cont)

Ckt. No.	Tektronix Part No.	Serial/Model No. Eff	Disc	Description		
Resistors (cont)						
R706	315-0753-00		75 kΩ	1/4 W		5%
R711	315-0753-00		75 kΩ	1/4 W		5%
R712	315-0154-00		150 kΩ	1/4 W		5%
R713	315-0753-00		75 kΩ	1/4 W		5%
R721	315-0753-00		75 kΩ	1/4 W		5%
R722	315-0154-00		150 kΩ	1/4 W		5%
R723	315-0154-00		150 kΩ	1/4 W		5%
R724	321-0356-00		49.9 kΩ	1/8 W	Prec	1%
R727	321-0335-00		30.1 kΩ	1/8 W	Prec	1%
R728	321-0344-00		37.4 kΩ	1/8 W	Prec	1%
R729	315-0154-00		150 kΩ	1/4 W		5%
R741	321-0229-00		2.37 kΩ	1/8 W	Prec	1%
R830	315-0160-00		16 Ω	1/4 W		5%

TRIGGER MODE Circuit Board Assembly

*670-1143-00	B010100	B029999	Complete Board
*670-1143-01	B030000	B099999	Complete Board
*670-1143-02	B100000		Complete Board

Bulbs

DS274	*150-0057-01	B010100	B099999	Incandescent, 7153AS15, selected
DS274	*150-0048-01	B100000		Incandescent, #683, selected
DS446	*150-0057-01	B010100	B099999	Incandescent, 7153AS15, selected
DS446	*150-0048-01	B100000		Incandescent, #683, selected

Resistors

Resistors are fixed, composition, ±10% unless otherwise indicated.

R264	321-0385-00	B010100	B029999	100 kΩ	1/8 W	Prec	1%
R264	321-0338-00	B030000		32.4 kΩ	1/8 W	Prec	1%
R273	321-0326-00	B010100	B029999	24.3 kΩ	1/8 W	Prec	1%
R273	321-0305-00	B030000		14.7 kΩ	1/8 W	Prec	1%

Switch

Wired or Unwired

S273 ⁵	*670-1143-00	B010100	B029999	Pushbutton	MODE
S273 ⁵	*670-1143-01	B030000	B099999	Pushbutton	MODE
S273 ⁵	*670-1143-02	B100000		Pushbutton	MODE

⁵See Mechanical Parts List for replacement parts.

COUPLING Circuit Board Assembly

Ckt. No.	Tektronix Part No.	Serial/Model No. Eff	Disc	Description
	*670-1146-00	B010100	B029999	Complete Board
	*670-1146-01	B030000	B099999	Complete Board
	*670-1146-02	B100000		Complete Board

Bulb

DS270	*150-0057-01	B010100	B099999	Incandescent, 7153AS15, selected
DS270	*150-0048-01			Incandescent, #683, selected

Capacitor

Tolerance $\pm 20\%$ unless otherwise indicated.

C270	283-0189-00	B010100	B029999	0.1 μF	Cer	400 V
C270	283-0026-00	B030000		0.2 μF	Cer	25 V

Resistor

Resistors are fixed, composition, $\pm 10\%$ unless otherwise indicated.

R271	321-0381-00	B010100	B029999	90.9 k Ω	$\frac{1}{8}$ W	Prec	1%
R271	321-0325-00	B030000		23.7 k Ω	$\frac{1}{8}$ W	Prec	1%

Switch

Wired or Unwired

S270 ⁶	*670-1146-00	B010100	B029999	Pushbutton	COUPLING
S270 ⁶	*670-1146-01	B030000	B099999	Pushbutton	COUPLING
S270 ⁶	*670-1146-02	B100000		Pushbutton	COUPLING

TIME BASE Circuit Board Assembly

*670-1169-00	B010100	B069999	Complete Board
*670-1169-01	B070000	B089999	Complete Board
*670-1169-02	B090000	B129999	Complete Board
*670-1169-03	B130000		Complete Board

Capacitors

Tolerance $\pm 20\%$ unless otherwise indicated.

C404	283-0080-00		0.022 μF	Cer	25 V	+80%—20%
C407	283-0080-00		0.022 μF	Cer	25 V	+80%—20%
C421	283-0080-00		0.022 μF	Cer	25 V	+80%—20%
C431	283-0080-00		0.022 μF	Cer	25 V	+80%—20%
C434	281-0577-00		14 pF	Cer	500 V	5%

⁶See Mechanical Parts List for replacement parts.

TIME BASE Circuit Board Assembly (cont)

Ckt. No.	Tektronix Part No.	Serial/Model No. Eff	Disc	Description		
Capacitors (cont)						
C441	283-0080-00			0.022 μ F	Cer	25 V +80%—20%
C446	290-0136-00			2.2 μ F	Elect.	20 V
C456	290-0135-00	B010100	B079999	15 μ F	Elect.	20 V
C456	290-0136-00	B080000		2.2 μ F	Elect.	20 V
C457	281-0524-00			150 pF	Cer	500 V
C466	283-0080-00			0.022 μ F	Cer	25 V +80%—20%
C469	283-0000-00			0.001 μ F	Cer	500 V
C488	290-0136-00			2.2 μ F	Elect.	20 V
C497	290-0136-00			2.2 μ F	Elect.	20 V
C499	290-0136-00			2.2 μ F	Elect.	20 V
C501	290-0134-00			22 μ F	Elect.	15 V
C516	283-0080-00			0.022 μ F	Cer	25 V +80%—20%
C524	281-0524-00			150 pF	Cer	500 V
C527	281-0523-00			100 pF	Cer	350 V
C530J	281-0093-00			5.5-19 pF, Var	Cer	
C530K	283-0126-00			82 pF	Cer	1000 V 5%
C530L	281-0091-00			2-8 pF, Var	Cer	
C530M	281-0657-00			13 pF	Cer	500 V 2%
C532	283-0080-00			0.022 μ F	Cer	25 V +80%—20%
C535	283-0000-00			0.001 μ F	Cer	500 V
C536	290-0136-00			2.2 μ F	Elect.	20 V
C545	290-0136-00			2.2 μ F	Elect.	20 V
C551	281-0523-00			100 pF	Cer	350 V
C556	281-0552-00			25 pF	Cer	500 V
C561	290-0136-00			2.2 μ F	Elect.	20 V
C580A	283-0164-00			2.2 μ F	Cer	25 V
C580B	283-0191-00			0.022 μ F	Cer	50 V
C580D	283-0666-00			890 pF	Mica	100 V 2%
C583	283-0080-00			0.022 μ F	Cer	25 V +80%—20%
C591	281-0523-00			100 pF	Cer	350 V
C592	281-0546-00			330 pF	Cer	500 V 10%
C746	283-0080-00			0.022 μ F	Cer	25 V +80%—20%
C748	283-0080-00			0.022 μ F	Cer	25 V +80%—20%
C752	283-0080-00	XB070000		0.022 μ F	Cer	25 V +80%—20%
C763	281-0557-00			1.8 pF	Cer	500 V \pm 0.1 pF
C788	283-0164-00			2.2 μ F	Cer	25 V 10%
C789	283-0092-00			0.03 μ F	Cer	200 V +80%—20%
C799	290-0136-00			2.2 μ F	Elect.	20 V
C801	290-0420-00			0.68 μ F	Elect.	75 V
C803	290-0136-00			2.2 μ F	Elect.	20 V
C805	290-0136-00			2.2 μ F	Elect.	20 V
C807	290-0136-00			2.2 μ F	Elect.	20 V
C809	283-0080-00			0.022 μ F	Cer	25 V +80%—20%

TIME BASE Circuit Board Assembly (cont)

Ckt. No.	Tektronix Part No.	Serial/Model No. Eff	Disc	Description		
Capacitors (cont)						
C811	283-0080-00		0.022 μ F	Cer	25 V	+80% - 20%
C813	290-0136-00		2.2 μ F	Elect.	20 V	
C815	290-0136-00		2.2 μ F	Elect.	20 V	
C817	290-0136-00		2.2 μ F	Elect.	20 V	
C819	290-0136-00		2.2 μ F	Elect.	20 V	
C821	290-0420-00		0.68 μ F	Elect.	75 V	

Semiconductor Device, Diodes

CR406	*152-0185-00		Silicon	Replaceable by 1N4152		
CR412	*152-0185-00		Silicon	Replaceable by 1N4152		
CR413	*152-0185-00		Silicon	Replaceable by 1N4152		
CR414	*152-0185-00		Silicon	Replaceable by 1N4152		
CR419	*152-0185-00		Silicon	Replaceable by 1N4152		
CR427	*152-0185-00		Silicon	Replaceable by 1N4152		
CR428	*152-0185-00		Silicon	Replaceable by 1N4152		
CR431	*152-0185-00		Silicon	Replaceable by 1N4152		
CR436	*152-0185-00		Silicon	Replaceable by 1N4152		
CR446	*152-0185-00		Silicon	Replaceable by 1N4152		
CR448	*152-0185-00		Silicon	Replaceable by 1N4152		
CR449	*152-0185-00		Silicon	Replaceable by 1N4152		
CR451	*152-0185-00		Silicon	Replaceable by 1N4152		
CR452	*152-0185-00		Silicon	Replaceable by 1N4152		
CR453	*152-0185-00		Silicon	Replaceable by 1N4152		
CR454	*152-0185-00		Silicon	Replaceable by 1N4152		
CR459	*152-0185-00		Silicon	Replaceable by 1N4152		
CR462	*152-0185-00		Silicon	Replaceable by 1N4152		
CR463	*152-0185-00		Silicon	Replaceable by 1N4152		
CR464	*152-0185-00		Silicon	Replaceable by 1N4152		
CR465	*152-0185-00		Silicon	Replaceable by 1N4152		
CR466	*152-0185-00		Silicon	Replaceable by 1N4152		
CR467	*152-0185-00		Silicon	Replaceable by 1N4152		
CR468	*152-0185-00		Silicon	Replaceable by 1N4152		
CR469	*152-0185-00		Silicon	Replaceable by 1N4152		
CR472	*152-0185-00		Silicon	Replaceable by 1N4152		
CR493	*152-0185-00		Silicon	Replaceable by 1N4152		
CR494	*152-0185-00		Silicon	Replaceable by 1N4152		
CR498	*152-0185-00		Silicon	Replaceable by 1N4152		
CR526	*152-0185-00		Silicon	Replaceable by 1N4152		

TIME BASE Circuit Board Assembly (cont)

Ckt. No.	Tektronix Part No.	Serial/Model No. Eff	Disc	Description
Semiconductor Device, Diodes (cont)				
CR528	*152-0185-00		Silicon	Replaceable by 1N4152
CR529	152-0246-00		Silicon	Low leakage 250 mW, 40.V
CR534	*152-0185-00		Silicon	Replaceable by 1N4152
CR548	152-0141-02		Silicon	1N4152
CR571	*152-0185-00		Silicon	Replaceable by 1N4152
CR572	*152-0185-00		Silicon	Replaceable by 1N4152
VR573	152-0279-00		Zener	1N751A 400 mW, 5.1 V, 5%
CR574	*152-0185-00		Silicon	Replaceable by 1N4152
CR575	*152-0185-00		Silicon	Replaceable by 1N4152
CR576	*152-0185-00		Silicon	Replaceable by 1N4152
VR576	152-0326-00		Zener	1N755A 400 mW, 7.5 V, 5%
CR580	*152-0185-00		Silicon	Replaceable by 1N4152
CR581	*152-0185-00		Silicon	Replaceable by 1N4152
CR582	*152-0185-00		Silicon	Replaceable by 1N4152
CR596	*152-0307-00		Silicon	Dual, Tek Spec
CR597	*152-0185-00		Silicon	Replaceable by 1N4152
CR598	*152-0185-00		Silicon	Replaceable by 1N4152
Relay				
K780	*148-0034-00			Armature, dpdt, 15 V DC
Inductor				
L593	*108-0440-00			8 μ H
Transistors				
Q402	151-0188-00		Silicon	2N3906
Q406	*151-0190-01		Silicon	Tek Spec
Q408	*151-0190-01		Silicon	Tek Spec
Q410	151-0188-00		Silicon	2N3906
Q416	*151-0190-01		Silicon	Tek Spec
Q424	*151-0190-01		Silicon	Tek Spec
Q432	151-0188-00		Silicon	2N3906
Q436	151-0188-00		Silicon	2N3906
Q442	151-0188-00		Silicon	2N3906
Q446	151-0207-00		Silicon	2N3415

TIME BASE Circuit Board Assembly (cont)

Ckt. No.	Tektronix Part No.	Serial/Model No. Eff	Disc	Description
Transistors (cont)				
Q454	*151-0190-01			Silicon Tek Spec
Q456	*151-0190-01			Silicon Tek Spec
Q468	*151-0190-01			Silicon Tek Spec
Q472	151-0188-00			Silicon 2N3906
Q482	*151-0190-01			Silicon Tek Spec
Q492	*151-0190-01			Silicon Tek Spec
Q496	*151-0190-01			Silicon Tek Spec
Q510	*151-0261-00			Silicon Dual, Tek Spec
Q520	*151-1036-00			Silicon Dual, FET, Tek Spec
Q526	*151-0289-00			Silicon Tek Spec
Q532	*151-1036-00			Silicon Dual, FET, Tek Spec
Q534	151-0188-00			Silicon 2N3906
Q546	151-0220-00			Silicon 2N4122
Q554	*151-0190-01			Silicon Tek Spec
Q564	*151-0190-01			Silicon Tek Spec
Q566	*151-0190-01			Silicon Tek Spec
Q582	151-0188-00			Silicon 2N3906
Q592	151-0232-00			Silicon Dual
Q752	*151-0289-00	XB070000		Silicon Tek Spec
Q753	*151-0190-01			Silicon Tek Spec
Q764	*151-0190-01			Silicon Tek Spec
Q774	*151-0190-01			Silicon Tek Spec
Q784	151-0220-00			Silicon 2N4122
Q794	151-0220-00			Silicon 2N4122

ResistorsResistors are fixed, composition, $\pm 10\%$ unless otherwise indicated.

R400	315-0101-00			100 Ω	$\frac{1}{4}$ W		5%
R402	315-0751-00			750 Ω	$\frac{1}{4}$ W		5%
R404	315-0151-00			150 Ω	$\frac{1}{4}$ W		5%
R406	315-0103-00			10 k Ω	$\frac{1}{4}$ W		5%
R407	315-0151-00			150 Ω	$\frac{1}{4}$ W		5%
R408	321-0174-00			634 Ω	$\frac{1}{8}$ W	Prec	1%
R409	321-0252-00	B010100	B089999	4.12 k Ω	$\frac{1}{8}$ W	Prec	1%
R409	321-0246-00	B090000		3.57 k Ω	$\frac{1}{8}$ W	Prec	1%
R410	315-0101-00			100 Ω	$\frac{1}{4}$ W		5%
R411	321-0277-00			7.5 k Ω	$\frac{1}{8}$ W	Prec	1%
R412	315-0153-00			15 k Ω	$\frac{1}{4}$ W		5%
R416	321-0315-00			18.7 k Ω	$\frac{1}{8}$ W	Prec	1%
R418	321-0222-00			2 k Ω	$\frac{1}{8}$ W	Prec	1%
R419	315-0221-00			220 Ω	$\frac{1}{4}$ W		5%
R421	315-0431-00			430 Ω	$\frac{1}{4}$ W		5%
R422	315-0112-00			1.1 k Ω	$\frac{1}{4}$ W		5%

TIME BASE Circuit Board Assembly (cont)

Ckt. No.	Tektronix Part No.	Serial/Model No. Eff	Disc	Description		
Resistors (cont)						
R423	315-0220-00		22 Ω	$\frac{1}{4}$ W		5%
R424	315-0302-00		3 k Ω	$\frac{1}{4}$ W		5%
R426	315-0132-00		1.3 k Ω	$\frac{1}{4}$ W		5%
R427	315-0561-00		560 Ω	$\frac{1}{4}$ W		5%
R428	321-0300-00		13 k Ω	$\frac{1}{8}$ W	Prec	1%
R431	315-0470-00		47 Ω	$\frac{1}{4}$ W		5%
R432	321-0136-00		255 Ω	$\frac{1}{8}$ W	Prec	1%
R433	321-0129-00		215 Ω	$\frac{1}{8}$ W	Prec	1%
R434	321-0265-00		5.62 k Ω	$\frac{1}{8}$ W	Prec	1%
R435	321-0244-00		3.4 k Ω	$\frac{1}{8}$ W	Prec	1%
R436	321-0167-00		536 Ω	$\frac{1}{8}$ W	Prec	1%
R438	301-0102-00		1 k Ω	$\frac{1}{2}$ W		5%
R441	301-0470-00		47 Ω	$\frac{1}{2}$ W		5%
R444	315-0102-00		1 k Ω	$\frac{1}{4}$ W		5%
R448	321-0277-00		7.5 k Ω	$\frac{1}{8}$ W	Prec	1%
R449	315-0472-00		4.7 k Ω	$\frac{1}{4}$ W		5%
R451	315-0223-00		22 k Ω	$\frac{1}{4}$ W		5%
R452	315-0153-00		15 k Ω	$\frac{1}{4}$ W		5%
R454	315-0472-00		4.7 k Ω	$\frac{1}{4}$ W		5%
R455	315-0682-00		6.8 k Ω	$\frac{1}{4}$ W		5%
R456	315-0153-00		15 k Ω	$\frac{1}{4}$ W		5%
R458	315-0103-00		10 k Ω	$\frac{1}{4}$ W		5%
R459	315-0123-00		12 k Ω	$\frac{1}{4}$ W		5%
R462	315-0752-00		7.5 k Ω	$\frac{1}{4}$ W		5%
R464	321-0271-00		6.49 k Ω	$\frac{1}{8}$ W	Prec	1%
R465	321-0234-00		2.67 k Ω	$\frac{1}{8}$ W	Prec	1%
R466	321-0277-00		7.5 k Ω	$\frac{1}{8}$ W	Prec	1%
R468	321-0306-00		15 k Ω	$\frac{1}{8}$ W	Prec	1%
R469	321-0209-00		1.47 k Ω	$\frac{1}{8}$ W	Prec	1%
R470	321-0230-00	XB090000	2.43 k Ω	$\frac{1}{8}$ W	Prec	1%
R471	321-0271-00		6.49 k Ω	$\frac{1}{8}$ W	Prec	1%
R472	321-0193-00		1 k Ω	$\frac{1}{8}$ W	Prec	1%
R474	321-0150-00		357 Ω	$\frac{1}{8}$ W	Prec	1%
R475	321-0215-00		1.69 k Ω	$\frac{1}{8}$ W	Prec	1%
R477	321-0219-00		1.87 k Ω	$\frac{1}{8}$ W	Prec	1%
R482	321-0139-00		274 Ω	$\frac{1}{8}$ W	Prec	1%
R484	321-0241-00		3.16 k Ω	$\frac{1}{8}$ W	Prec	1%
R485	321-0196-00		1.07 k Ω	$\frac{1}{8}$ W	Prec	1%
R488	315-0101-00		100 Ω	$\frac{1}{4}$ W		5%
R489	321-0203-00		1.27 k Ω	$\frac{1}{8}$ W	Prec	1%
R493	315-0241-00		240 Ω	$\frac{1}{4}$ W		5%
R494	321-0222-00		2 k Ω	$\frac{1}{8}$ W	Prec	1%
R495	321-0203-00		1.27 k Ω	$\frac{1}{8}$ W	Prec	1%
R496	301-0152-00		1.5 k Ω	$\frac{1}{2}$ W		5%
R497	315-0331-00		330 Ω	$\frac{1}{4}$ W		5%
R498	315-0470-00		47 Ω	$\frac{1}{4}$ W		5%

TIME BASE Circuit Board Assembly (cont)

Ckt. No.	Tektronix Part No.	Serial/Model No. Eff	Disc	Description		
Resistors (cont)						
R499	315-0331-00			330 Ω	1/4 W	5%
R500	311-0950-00			10 k Ω , Var		
R501	321-0399-00			140 k Ω	1/8 W	Prec 1%
R503	321-0407-00			169 k Ω	1/8 W	Prec 1%
R511	321-0312-00			17.4 k Ω	1/8 W	Prec 1%
R512	321-0201-00			1.21 k Ω	1/8 W	Prec 1%
R515	322-0283-00			8.66 k Ω	1/4 W	Prec 1%
R516	315-0221-00			220 Ω	1/4 W	5%
R517	321-0312-00			17.4 k Ω	1/8 W	Prec 1%
R518	321-0201-00			1.21 k Ω	1/8 W	Prec 1%
R521	321-0299-00			12.7 k Ω	1/8 W	Prec 1%
R523	321-0266-00			5.76 k Ω	1/8 W	Prec 1%
R524	315-0222-00			2.2 k Ω	1/4 W	5%
R526	321-0269-00			6.19 k Ω	1/8 W	Prec 1%
R527	321-0193-00			1 k Ω	1/8 W	Prec 1%
R532	315-0122-00			1.2 k Ω	1/4 W	5%
R533	321-0219-00			1.87 k Ω	1/8 W	Prec 1%
R534	322-0281-00			8.25 k Ω	1/4 W	Prec 1%
R535	315-0470-00			47 Ω	1/4 W	5%
R536	315-0220-00			22 Ω	1/4 W	5%
R537	308-0306-00			3.26 k Ω	3 W	WW 2%
R539	315-0101-00			100 Ω	1/4 W	5%
R541	315-0131-00			130 Ω	1/4 W	5%
R542	321-0259-00			4.87 k Ω	1/8 W	Prec 1%
R543	315-0114-00	B010100	B129999X	110 k Ω	1/4 W	5%
R544	321-0231-00			2.49 k Ω	1/8 W	Prec 1%
R545	315-0470-00			47 Ω	1/4 W	5%
R546	301-0102-00			1 k Ω	1/2 W	5%
R548	301-0561-00			560 Ω	1/2 W	5%
R551	321-0211-00			1.54 k Ω	1/8 W	Prec 1%
R552	321-0231-00			2.49 k Ω	1/8 W	Prec 1%
R554	321-0178-00			698 Ω	1/8 W	Prec 1%
R556	321-0260-00			4.99 k Ω	1/8 W	Prec 1%
R557	321-0239-00			3.01 k Ω	1/8 W	Prec 1%
R558	321-0193-00			1 k Ω	1/8 W	Prec 1%
R561	315-0820-00			82 Ω	1/4 W	5%
R564	321-0207-00			1.4 k Ω	1/8 W	Prec 1%
R565	315-0911-00			910 Ω	1/4 W	5%
R566	315-0101-00			100 Ω	1/4 W	5%
R567	301-0162-00			1.6 k Ω	1/2 W	5%
R568	315-0470-00			47 Ω	1/4 W	5%
R573	321-0295-00			11.5 k Ω	1/8 W	Prec 1%
R580C	323-0222-00			2 k Ω	1/2 W	Prec 1%
R581	315-0223-00			22 k Ω	1/4 W	5%
R582	323-0289-00			10 k Ω	1/2 W	Prec 1%

TIME BASE Circuit Board Assembly (cont)

Ckt. No.	Tektronix Part No.	Serial/Model No. Eff	No. Disc	Description		
Resistors (cont)						
R583	315-0104-00			100 kΩ	1/4 W	5%
R590	311-0950-00			10 kΩ, Var		
R591	321-0277-00			7.5 kΩ	1/8 W	Prec 1%
R592	321-0143-00	B010100	B089999	301 Ω	1/8 W	Prec 1%
R592	321-0147-00	B090000		332 Ω	1/8 W	Prec 1%
R593	315-0221-00			220 Ω	1/4 W	5%
R594	322-0273-00			6.81 kΩ	1/4 W	Prec 1%
R596	322-0310-00			16.5 kΩ	1/4 W	Prec 1%
R599	322-0297-00			12.1 kΩ	1/4 W	Prec 1%
R715	315-0154-00			150 kΩ	1/4 W	5%
R743	315-0470-00			47 Ω	1/4 W	5%
R745	315-0220-00			22 Ω	1/4 W	5%
R746	321-0262-01			5.23 kΩ	1/8 W	Prec 1/2%
R747	315-0220-00			22 Ω	1/4 W	5%
R748	321-0373-00			75 kΩ	1/8 W	Prec 1%
R752	321-0219-00			1.87 kΩ	1/8 W	Prec 1%
R755	303-0103-00	XB070000		10 kΩ	1 W	5%
R763	323-0205-00			1.33 kΩ	1/2 W	Prec 1%
R764	303-0302-00			3 kΩ	1 W	5%
R771	315-0113-00			11 kΩ	1/4 W	5%
R772	321-0244-00			3.4 kΩ	1/8 W	Prec 1%
R773	321-0205-00			1.33 kΩ	1/8 W	Prec 1%
R774	303-0332-00			3.3 kΩ	1 W	5%
R781	323-0272-00			6.65 kΩ	1/2 W	Prec 1%
R782	321-0735-07			1.001 kΩ	1/8 W	Prec 1/10%
R783	315-0752-00			7.5 kΩ	1/4 W	5%
R784	321-0228-00			2.32 kΩ	1/8 W	Prec 1%
R785	311-0597-00			50 Ω, Var		
R786	321-0088-09			80.6 Ω	1/8 W	Prec 1%
R788	317-0472-00			4.7 kΩ	1/8 W	5%
R789	317-0103-00			10 kΩ	1/8 W	5%
R791	323-0272-00			6.65 kΩ	1/2 W	Prec 1%
R794	321-0235-00			2.74 kΩ	1/8 W	Prec 1%
R795	311-0541-00			20 kΩ, Var		
R796	321-0289-00			10 kΩ	1/8 W	Prec 1%
R797	321-0289-00			10 kΩ	1/8 W	Prec 1%
R799	315-0101-00			100 Ω	1/4 W	5%
R801	315-0510-00			51 Ω	1/4 W	5%
R803	315-0470-00			47 Ω	1/4 W	5%
R805	315-0470-00			47 Ω	1/4 W	5%
R807	315-0101-00			100 Ω	1/4 W	5%
R809	315-0101-00			100 Ω	1/4 W	5%
R811	315-0221-00			220 Ω	1/4 W	5%
R815	315-0470-00			47 Ω	1/4 W	5%
R817	315-0910-00			91 Ω	1/4 W	5%
R819	315-0101-00			100 Ω	1/4 W	5%
R821	315-0510-00			51 Ω	1/4 W	5%

B DELAY MODE Circuit Board Assembly

Ckt. No.	Tektronix Part No.	Serial/Model No. Eff	No. Disc	Description
	*670-1103-00	B010100	B099999	Complete Board
	*670-1103-01	B100000		Complete Board

Bulb

DS490	*150-0057-01	B010100	B099999	Incandescent, 7153AS15, selected
DS490	*150-0048-01	B100000		Incandescent, #683, selected

Resistors

Resistors are fixed, composition, $\pm 10\%$ unless otherwise indicated.

R490A	315-0820-00		82 Ω	$\frac{1}{4}$ W	5%
R490B	315-0201-00		200 Ω	$\frac{1}{4}$ W	5%

Switch

Wired or Unwired

S490 [†]	*670-1103-00	B010100	B099999	Pushbutton	B DELAY MODE
S490 [†]	*670-1103-01	B100000		Pushbutton	B DELAY MODE

SOURCE Circuit Board Assembly

*670-1145-00	B010100	B099999	Complete Board
*670-1145-01	B100000		Complete Board

Bulb

DS280	*150-0057-01	B010100	B099999	Incandescent, 7153AS15, selected
DS280	*150-0048-01			Incandescent, #683, selected

Switch

Wired or Unwired

S280 [†]	*670-1145-00	B010100	B099999	Pushbutton	SOURCE
S280 [†]	*670-1145-01	B100000		Pushbutton	SOURCE

[†]See Mechanical Parts List for replacement parts.

MAGNIFIER Circuit Board Assembly

Ckt. No.	Tektronix Part No.	Serial/Model No. Eff	Disc	Description	
	*670-1107-00	B010100	B099999	Complete Board	
	*670-1107-01	B100000		Complete Board	
Bulb					
DS780	*150-0057-01	B010100	B099999	Incandescent, 7153AS15, selected	
DS780	*150-0048-01	B100000		Incandescent, #683, selected	
Switch					
Wired or Unwired					
S780 ^s	*670-1107-00	B010100	B099999	Pushbutton	MAGNIFIER
S780 ^s	*670-1107-01	B100000		Pushbutton	MAGNIFIER

^sSee Mechanical Parts List for replacement parts.

SECTION 7 DIAGRAMS and MECHANICAL PARTS ILLUSTRATIONS

The following special symbols are used on the diagrams:

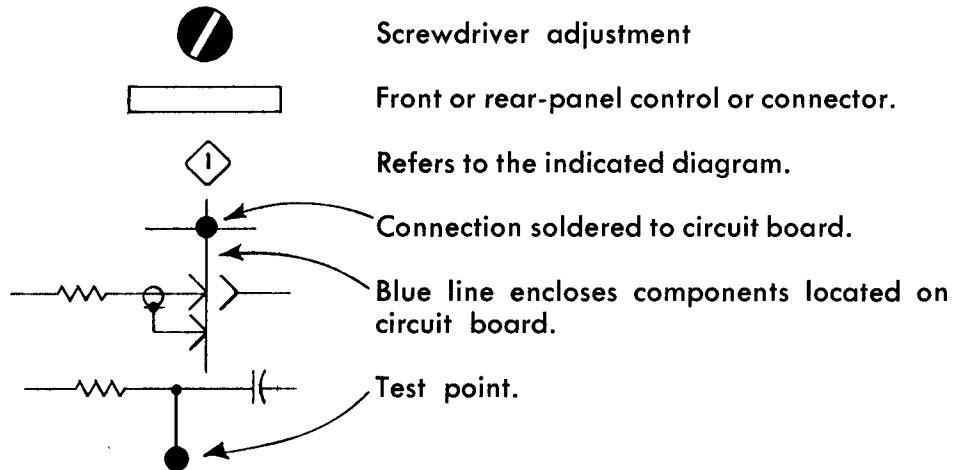

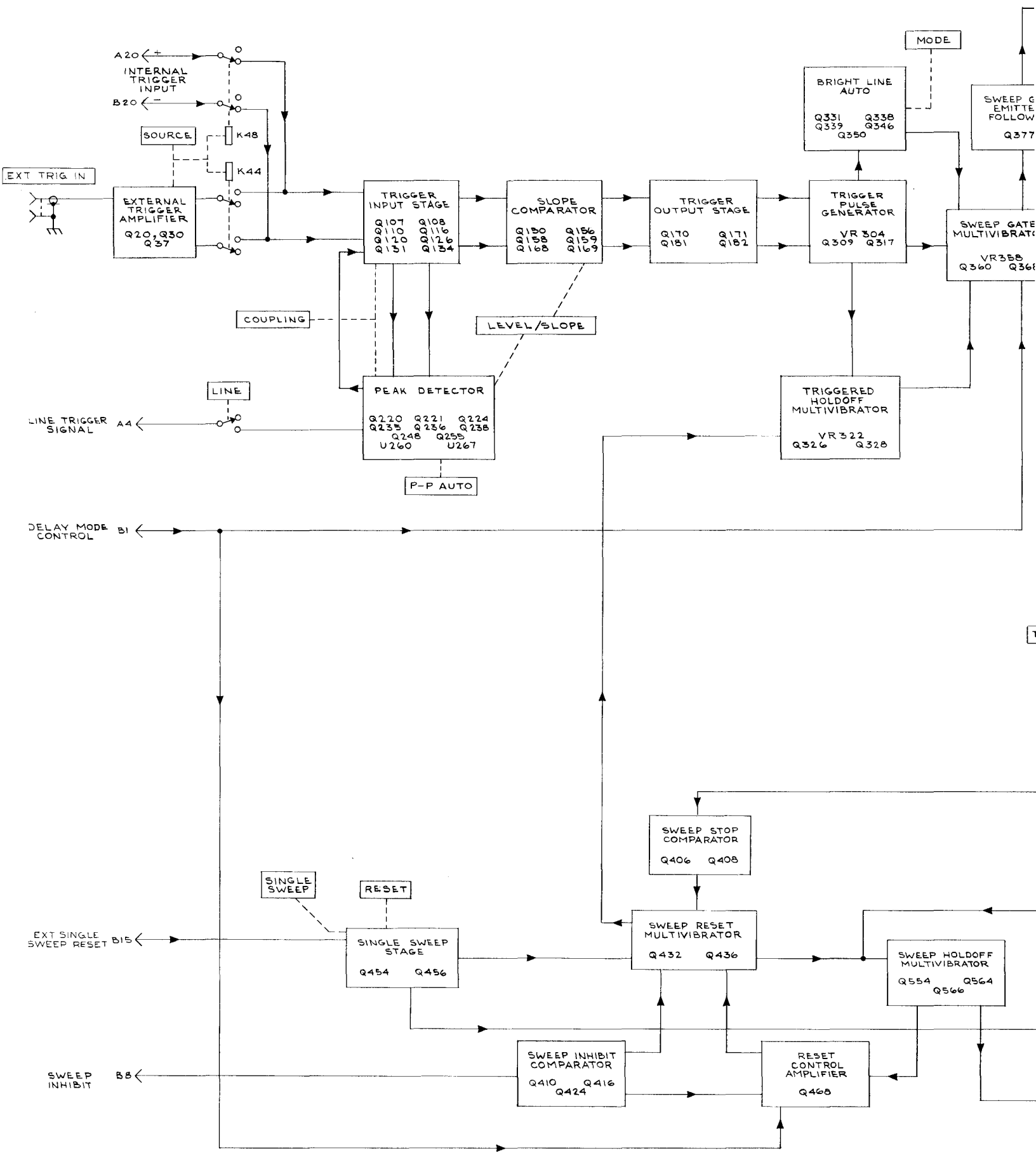

7B71 PLUG-IN

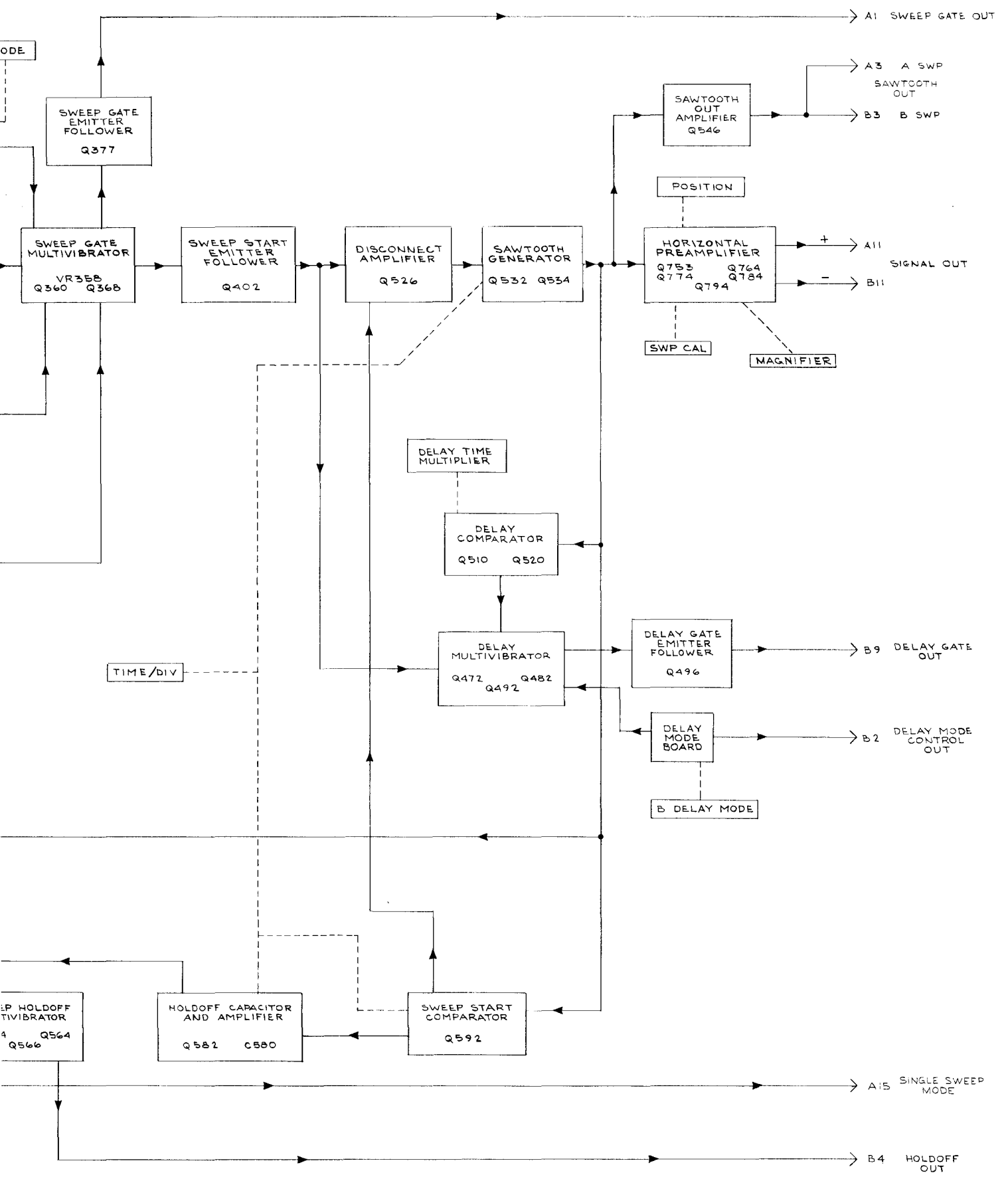

Ⓐ

BLOCK DIAGRAM

h_q
0270

VOLTAGE AND WAVEFORM TEST CONDITIONS

Typical voltage measurements were obtained under the following conditions unless noted otherwise on the individual diagrams.

7704

Vertical Mode	Left
Horizontal Mode	A
A Intensity	Optimum

7B70 (A Horiz Plug-In)

Level/Slope	Centered on positive slope
Triggering	
Mode	P-P Auto
Coupling	AC
Source	Ext
Magnifier	X1
Time/Div	1 ms
Variable Time/Div	Cal In
Display Mode	Time Base
Position	Centered

7A16 (Left Vertical Plug-In)

Polarity	+UP
Bandwidth	20 MHz
Volts/Div	1 V
Coupling	AC
Position	Centered

7B71 (B Horiz Plug-In)

LEVEL/SLOPE	Centered on positive slope
TRIGGERING	
MODE	P-P AUTO
COUPLING	AC
SOURCE	EXT
MAGNIFIER	X1
TIME/DIV	1 ms
B DELAY MODE	INDEPENDENT
DELAY TIME MULTIPLIER	0.00
POSITION	Centered
VARIABLE TIME/DIV	CAL IN

The following control settings and connections were changed to obtain waveform photographs.

7B70

Time/Div	As shown on waveforms
----------	-----------------------

7A16

Volts/Div	As shown on waveforms
-----------	-----------------------

Signal input: A one volt, one kilohertz sine-wave applied to both the 7B70 and 7B71 EXT TRIG IN connector.

All voltages given on the diagrams are in volts. Voltages taken using a Fairchild Model 7050 non-loading digital multimeter. Waveforms shown are actual waveform photographs taken with a Tektronix Oscilloscope Camera System and Projected Graticule. Voltages and waveforms on the diagrams (shown in blue) are not absolute and may vary between instruments because of differing component tolerances, internal calibration or front panel control settings.

VOLTAGE & WAVEFORM CONDITIONS

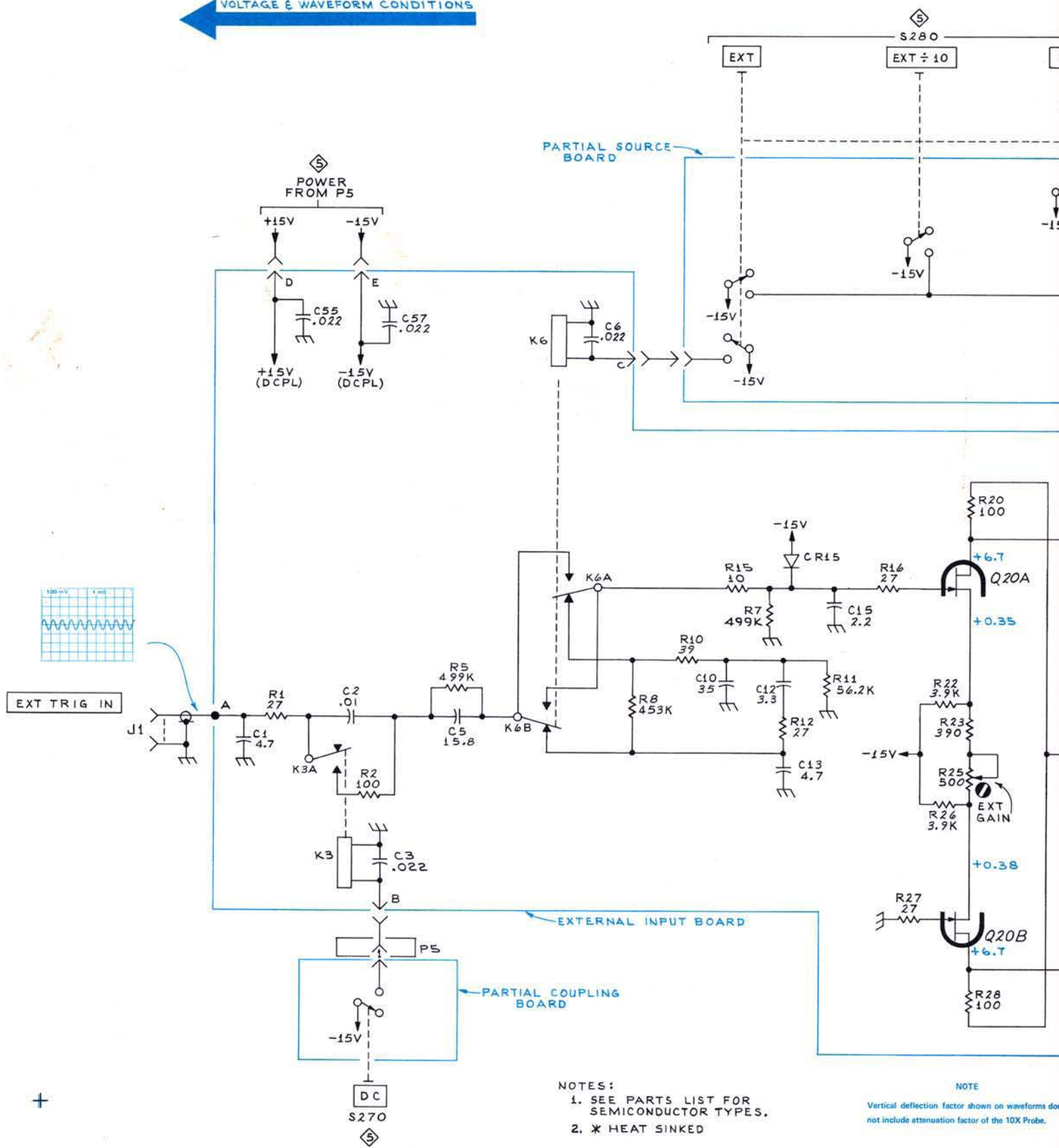

- NOTES:
1. SEE PARTS LIST FOR SEMICONDUCTOR TYPES.
 2. * HEAT SINKED

NOTE
Vertical deflection factor shown on waveforms does not include attenuation factor of the 10X Probe.

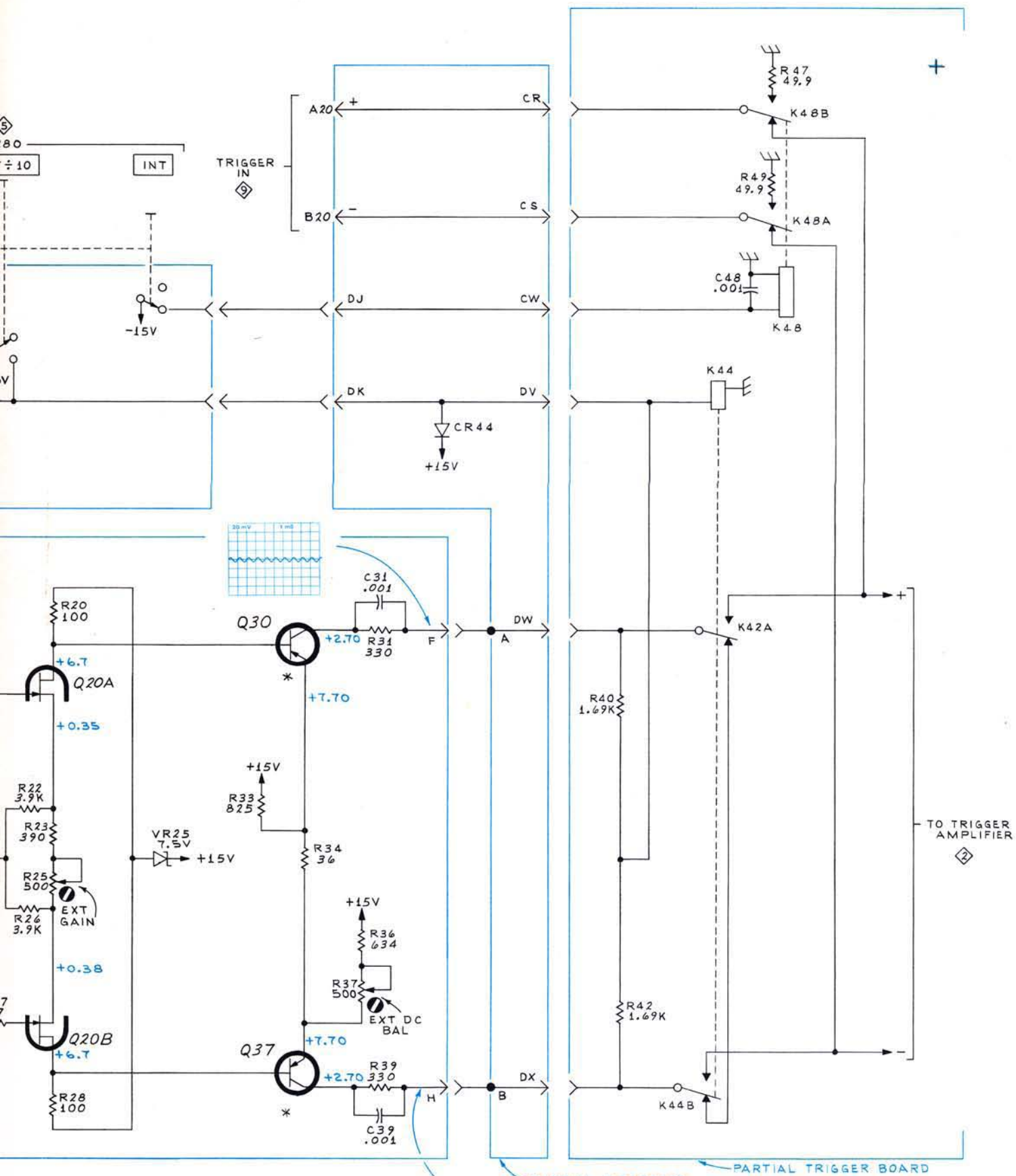

TRIGGER INPUT

1

NOTE
 Gain factor shown on waveforms does
 not include attenuation factor of the 10X Probe.

- REFERENCE DIAGRAM
- ② TRIGGER AMPLIFIER
 - ③ TRIGGERING SWITCHES
 - ④ DECOUPLING & OUTPUT CONNECTORS

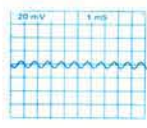

TRIGGER INPUT 1 WLB 0270



+

SEE PARTS LIST FOR SEMICONDUCTOR TYPES

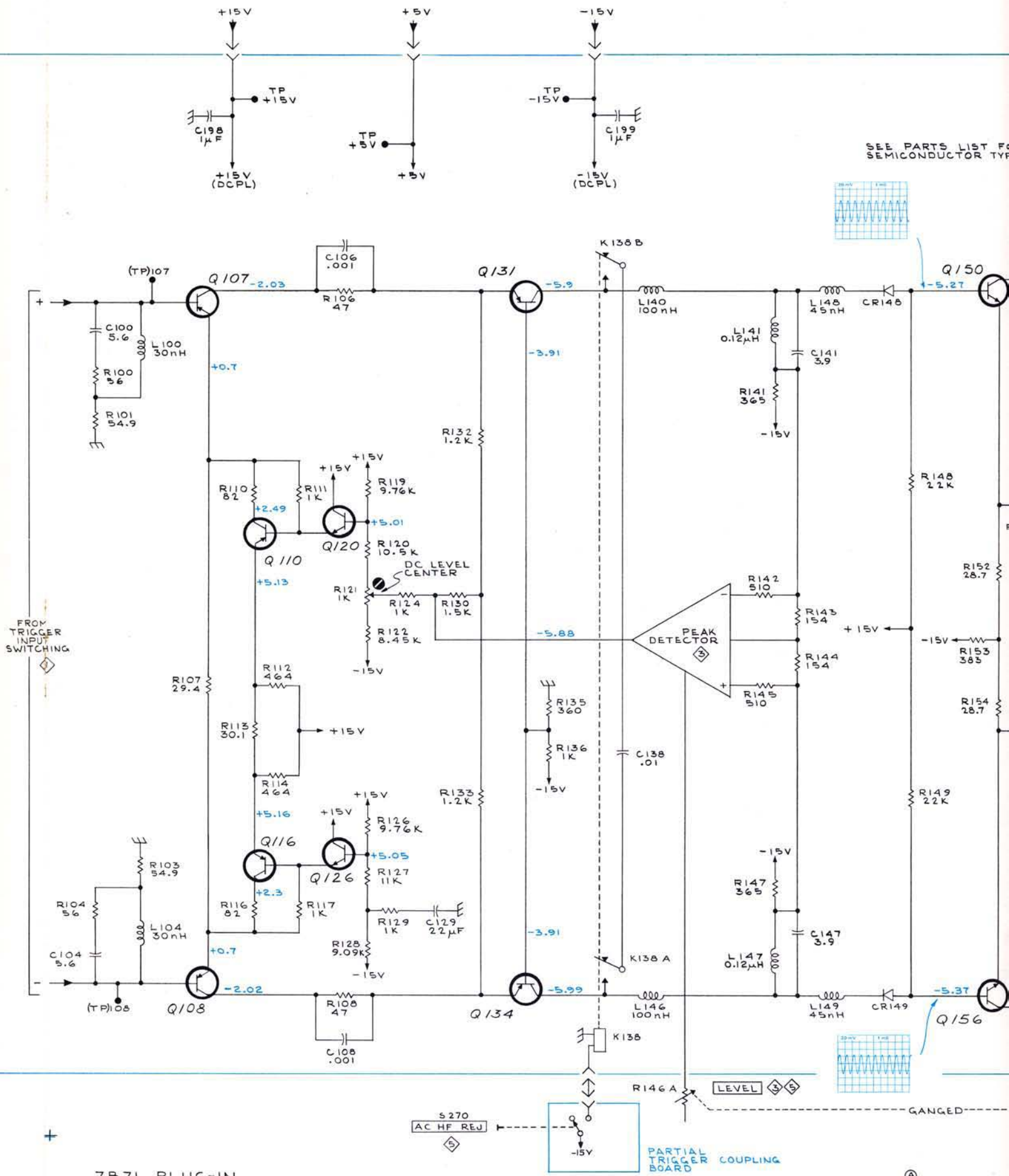

7B71 PLUG-IN

(A)

PARTIAL TRIGGER BOARD

NOTE

Vertical deflection factor shown on waveforms does not include attenuation factor of the 10X Probe.

VOLTAGES and WAVEFORMS obtained under conditions given on Diagram

REFERENCE DIAGRAM

- 1 TRIGGER INPUT
- 2 PEAK DETECTOR
- 3 TRIGGER GENERATOR
- 4 TRIGGERING SWITCHES

LIST FOR
DUCTOR TYPES

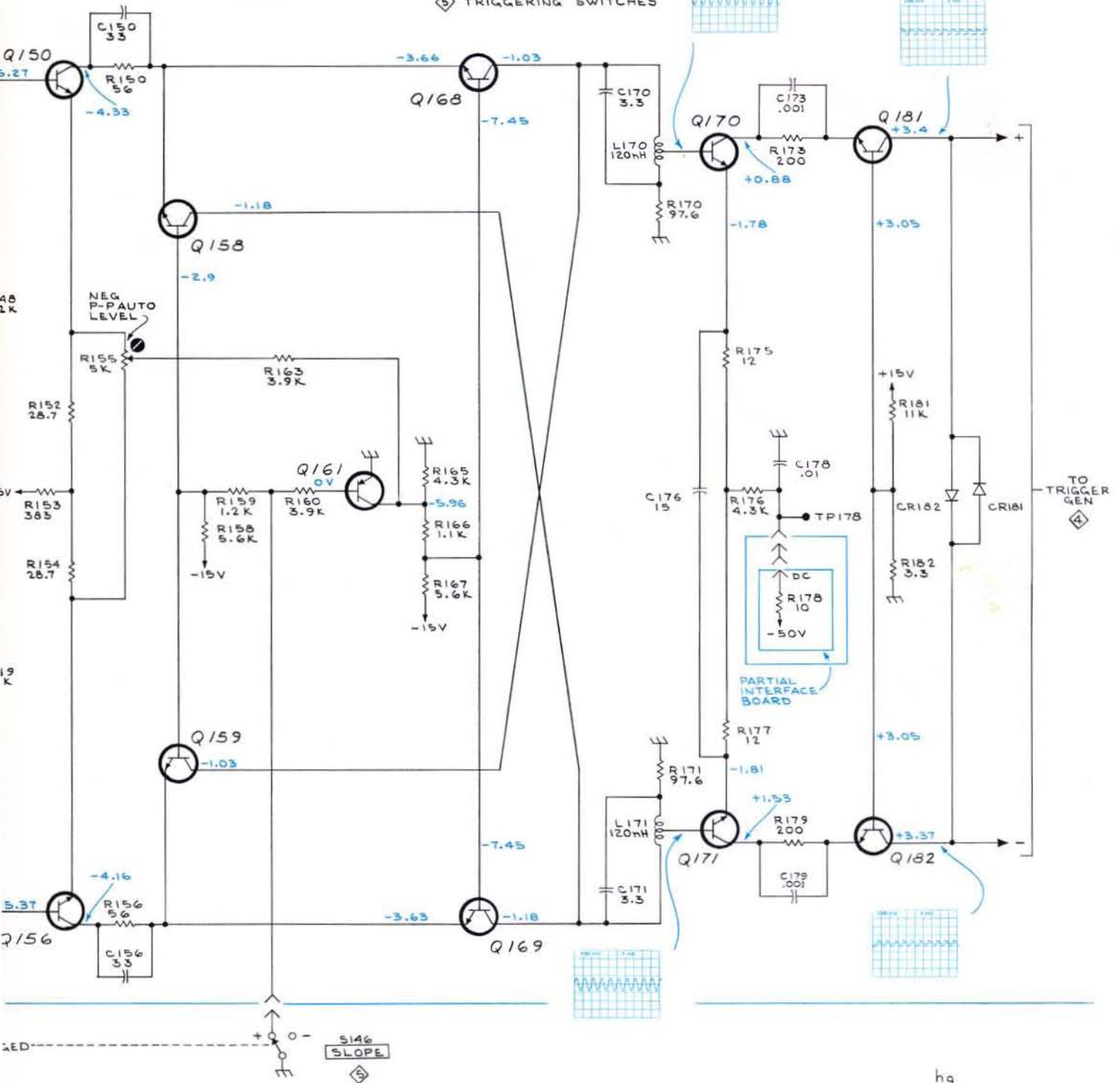

TRIGGER AMPLIFIER 2

TRIGGER AMPLIFIER 2

h9
0270

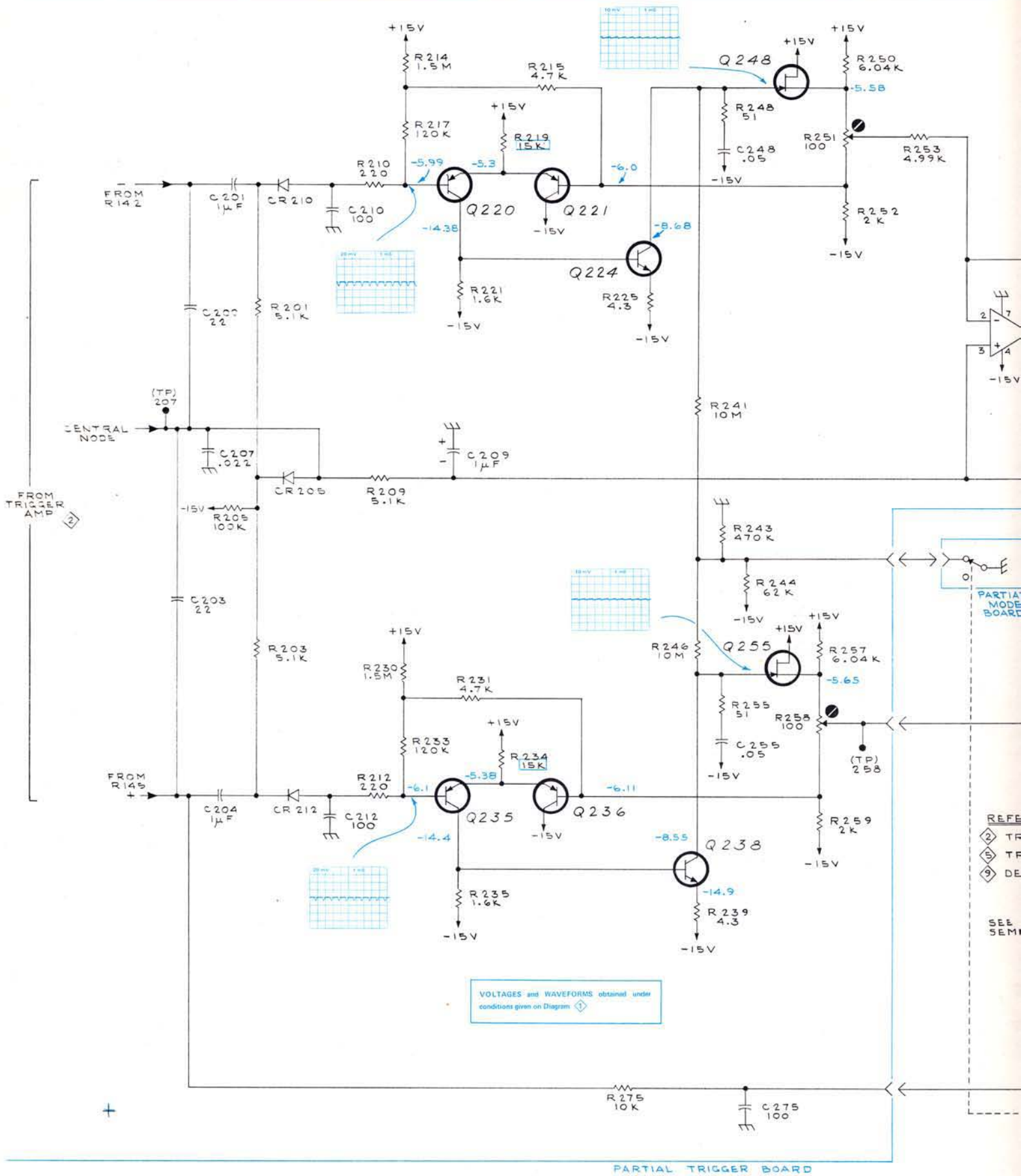

7B71 PLUG-IN

2.53
1.99K

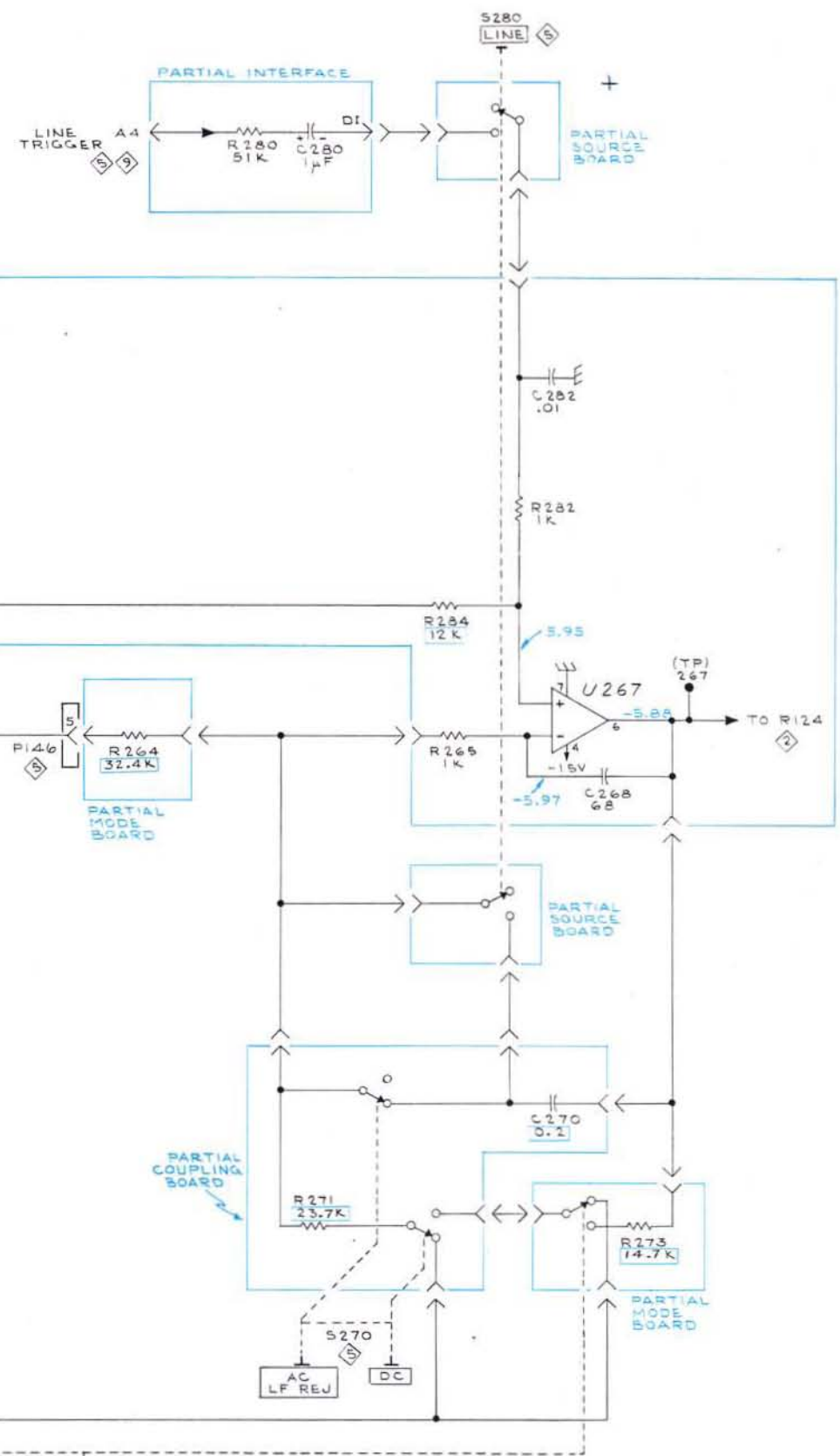
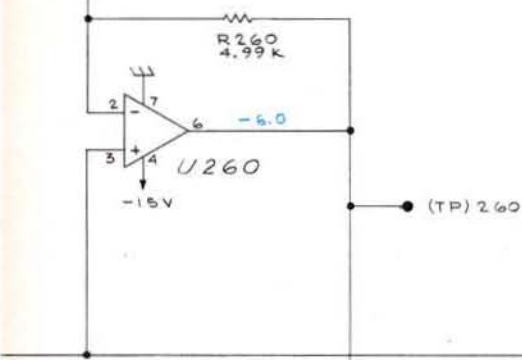

REFERENCE DIAGRAMS

- ② TRIGGER AMPLIFIER
- ⑤ TRIGGERING SWITCHES
- ⑨ DECOUPLING & OUTPUT CONNECTORS

SEE PARTS LIST FOR SEMICONDUCTOR TYPES

SEE PARTS LIST FOR EARLIER VALUES AND SERIAL NUMBER RANGES OF PARTS MARKED WITH BLUE OUTLINE.

NOTE

Vertical deflection factor shown on waveforms does not include attenuation factor of the 10X Probe.

P-P AUTO
5 273

PEAK DETECTOR ③

hq
0571

Vertical deflection
not include attenuator

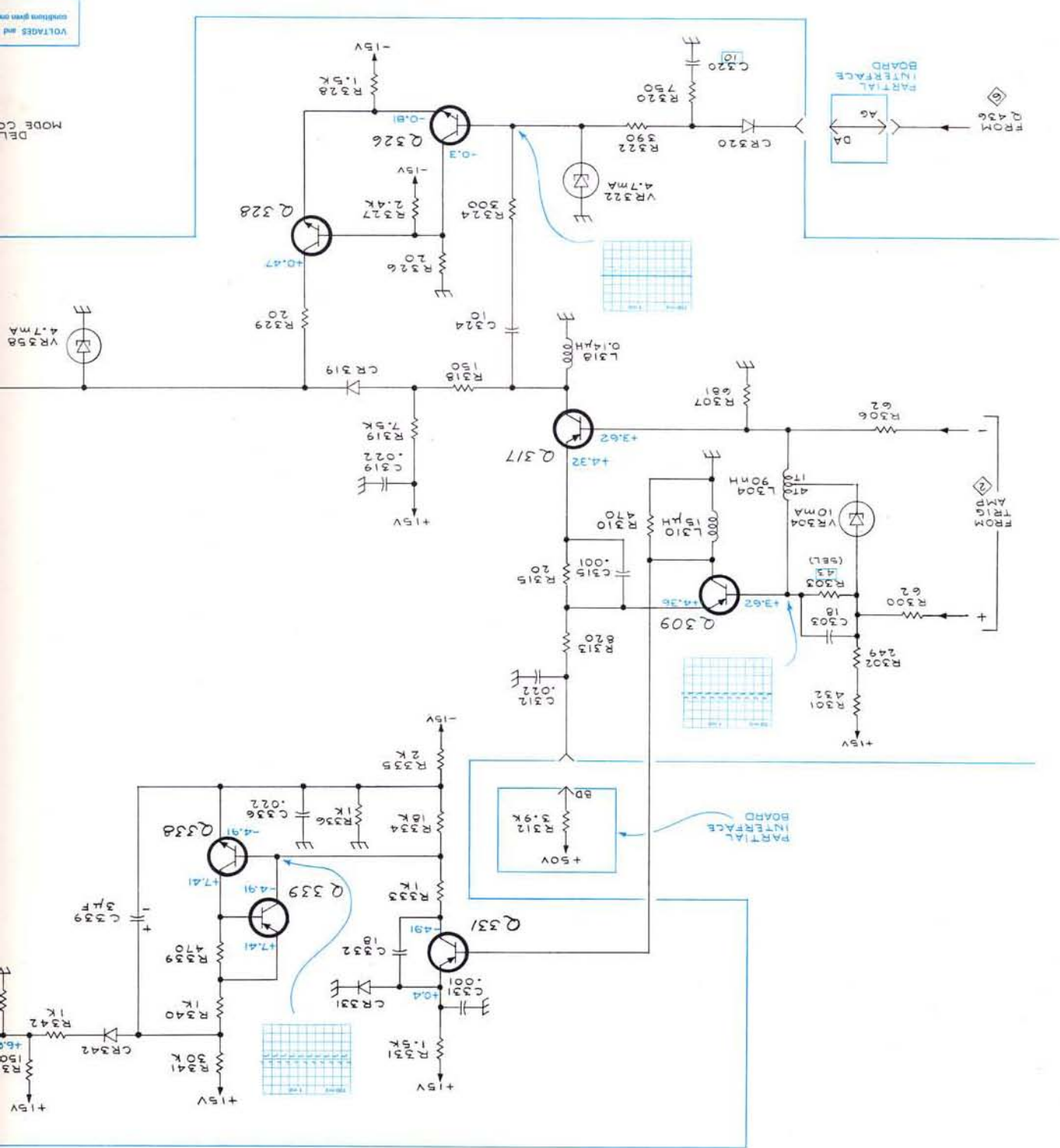

DEL MODE CC

VOLTAGES and
conditions given are

Vertical deflection
not include attenuator

VR358
4.7 mA

VR322
4.7 mA

VR358
4.7 mA

VR358
4.7 mA

VR358
4.7 mA

VR358
4.7 mA

VR358
4.7 mA

VR358
4.7 mA

VR358
4.7 mA

VR358
4.7 mA

VR358
4.7 mA

VR358
4.7 mA

VR358
4.7 mA

VR358
4.7 mA

VR358
4.7 mA

VR358
4.7 mA

VR358
4.7 mA

VR358
4.7 mA

VR358
4.7 mA

VR358
4.7 mA

VR358
4.7 mA

VR358
4.7 mA

VR358
4.7 mA

VR358
4.7 mA

VR358
4.7 mA

VR358
4.7 mA

VR358
4.7 mA

VR358
4.7 mA

VR358
4.7 mA

VR358
4.7 mA

VR358
4.7 mA

VR358
4.7 mA

VR358
4.7 mA

VR358
4.7 mA

VR358
4.7 mA

VR358
4.7 mA

VR358
4.7 mA

VR358
4.7 mA

VR358
4.7 mA

VR358
4.7 mA

VR358
4.7 mA

VR358
4.7 mA

VR358
4.7 mA

VR358
4.7 mA

VR358
4.7 mA

VR358
4.7 mA

VR358
4.7 mA

VR358
4.7 mA

VR358
4.7 mA

VR358
4.7 mA

VR358
4.7 mA

VR358
4.7 mA

VR358
4.7 mA

VR358
4.7 mA

VR358
4.7 mA

VR358
4.7 mA

VR358
4.7 mA

VR358
4.7 mA

VR358
4.7 mA

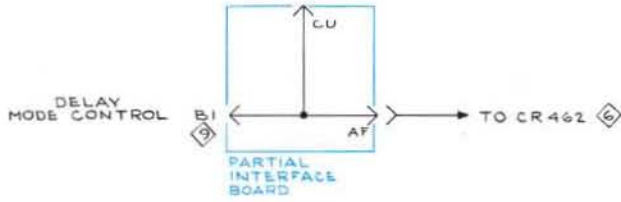
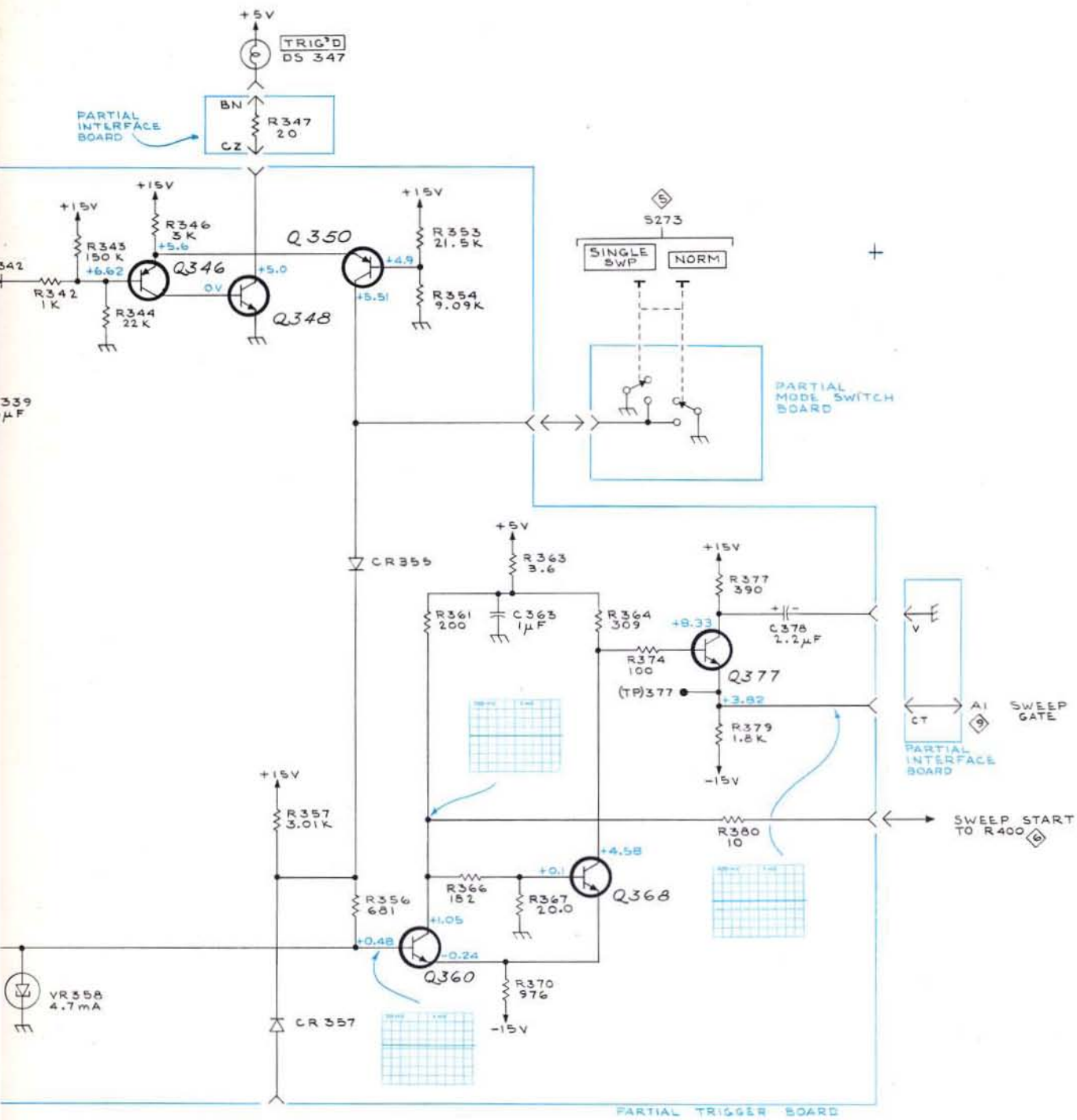

- REFERENCE DIAGRAMS
- ② TRIGGER AMPLIFIER
 - ⑤ TRIGGERING SWITCH
 - ⑥ TIME-BASE GENERATOR
 - ⑨ DECOUPLING & OUTPUT CONNECTORS

VOLTAGES and WAVEFORMS obtained under conditions given on Diagram ①

SEE PARTS LIST FOR SEMICONDUCTOR TYPES

NOTE
Vertical deflection factor shown on waveforms does not include attenuation factor of the 10X Probe.

SEE PARTS LIST FOR EARLIER VALUES AND SERIAL NUMBER RANGES OF PARTS MARKED WITH BLUE OUTLINE.

hq
971

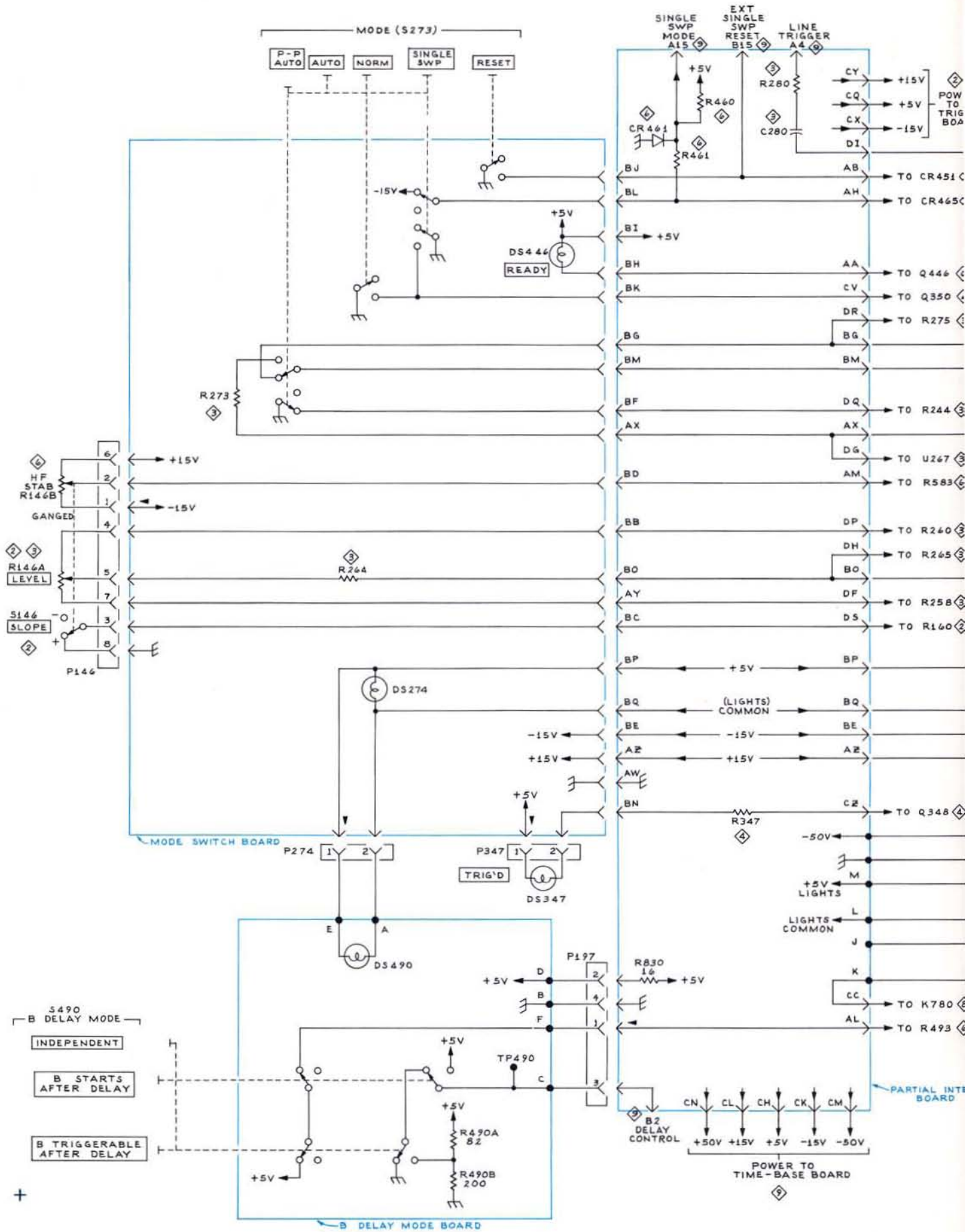

7B71 PLUG-IN

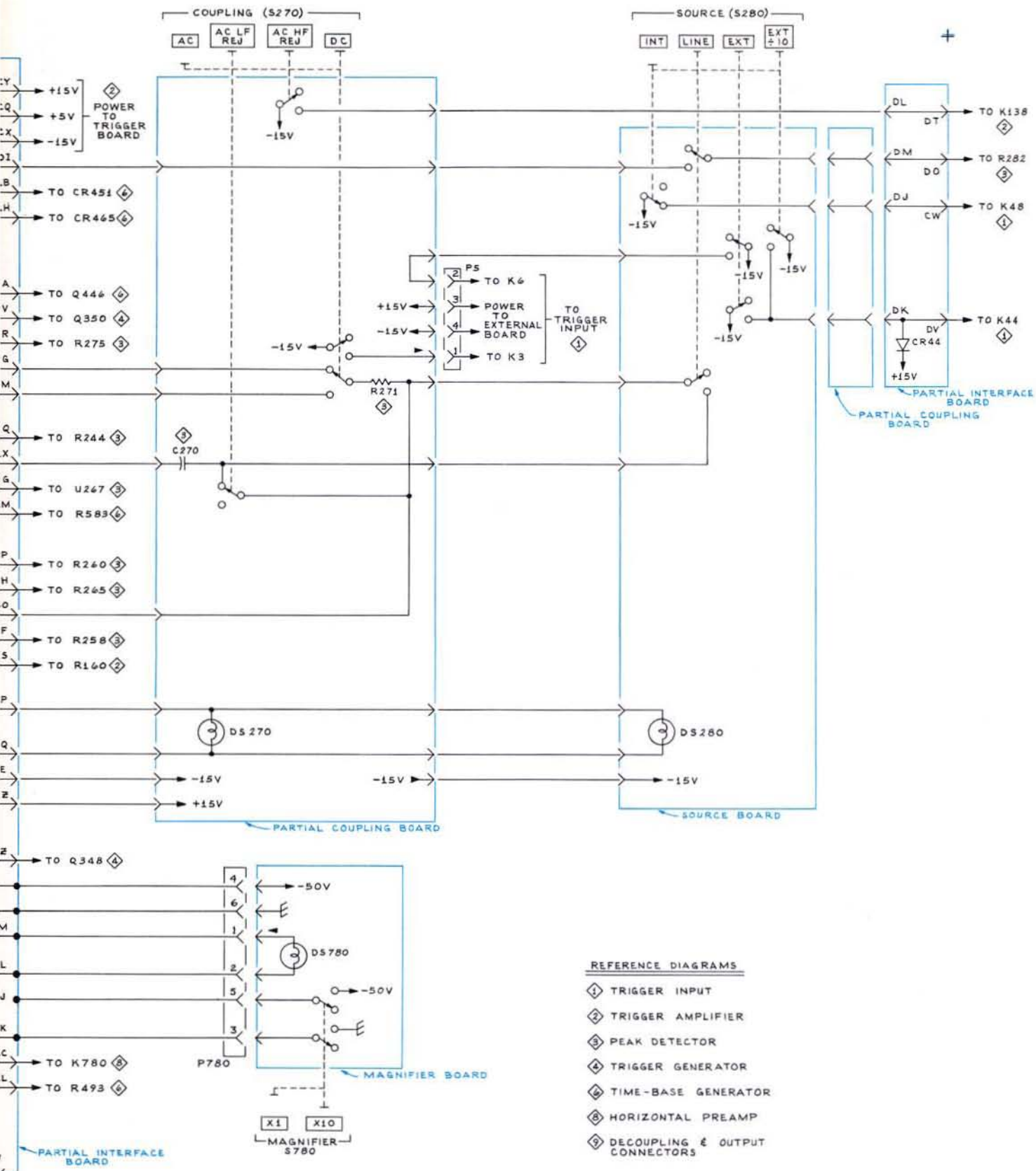

TRIGGERING SWITCHES

5

Delay pickup

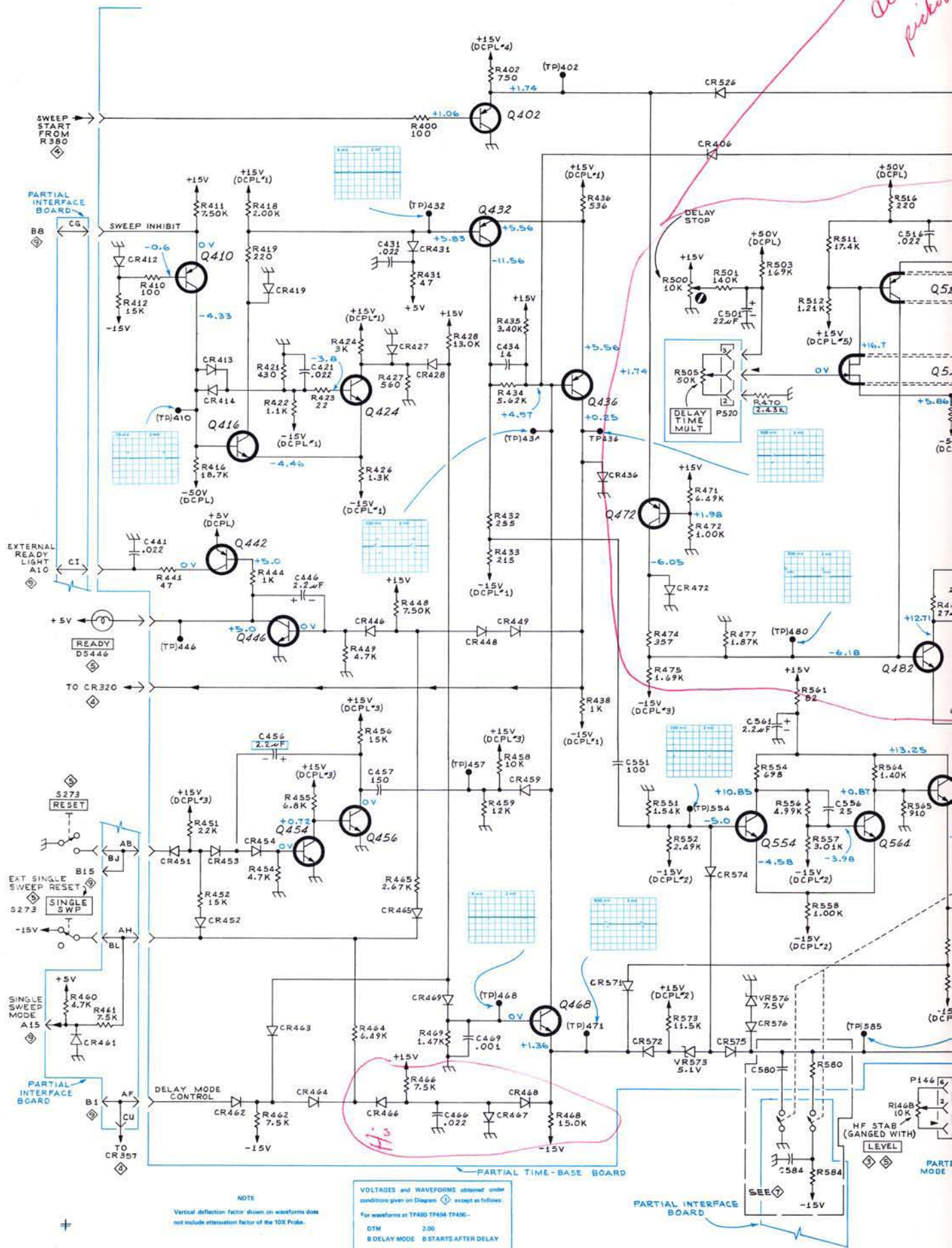

PARTIAL INTERFACE BOARD

EXTERNAL READY LIGHT A10

RESE

SINGLE SWP

SINGLE SWP MODE

PARTIAL INTERFACE BOARD

NOTE
Vertical deflection factor shown on waveforms does not include attenuation factor of the 10X Probe.

VOLTAGES and WAVEFORMS obtained under conditions given on Diagram except as follows:
DTM 2.00
B DELAY MODE B STARTS AFTER DELAY

7B71 PLUG-IN

Delay pickoff

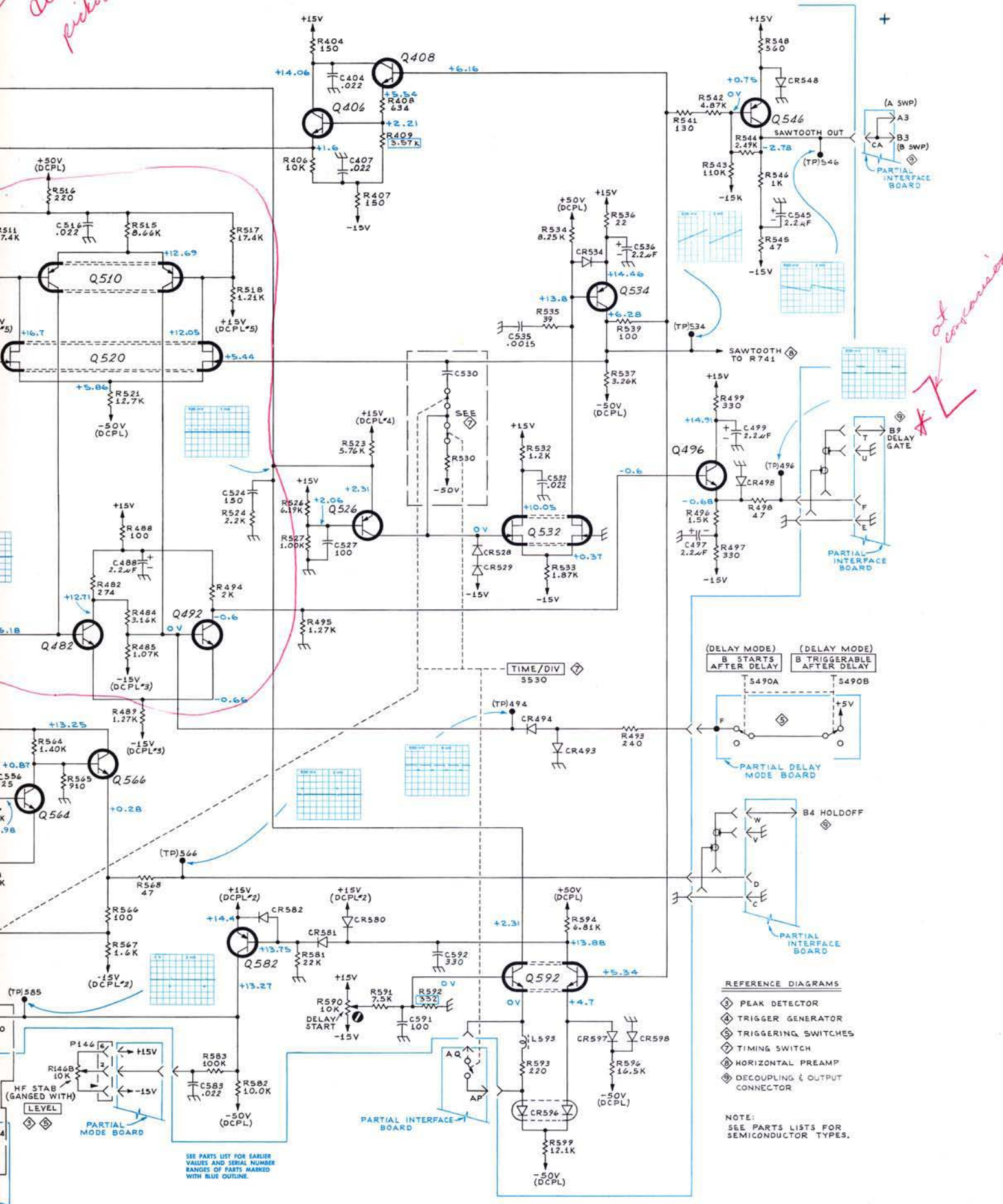

at conversion

- REFERENCE DIAGRAMS**
- ◆ PEAK DETECTOR
 - ◆ TRIGGER GENERATOR
 - ◆ TRIGGERING SWITCHES
 - ◆ TIMING SWITCH
 - ◆ HORIZONTAL PREAMP
 - ◆ DECOUPLING & OUTPUT CONNECTOR

NOTE: SEE PARTS LISTS FOR SEMICONDUCTOR TYPES.

SEE PARTS LIST FOR EARLIER VALUES AND SERIAL NUMBER RANGES OF PARTS MARKED WITH BLUE OUTLINE.

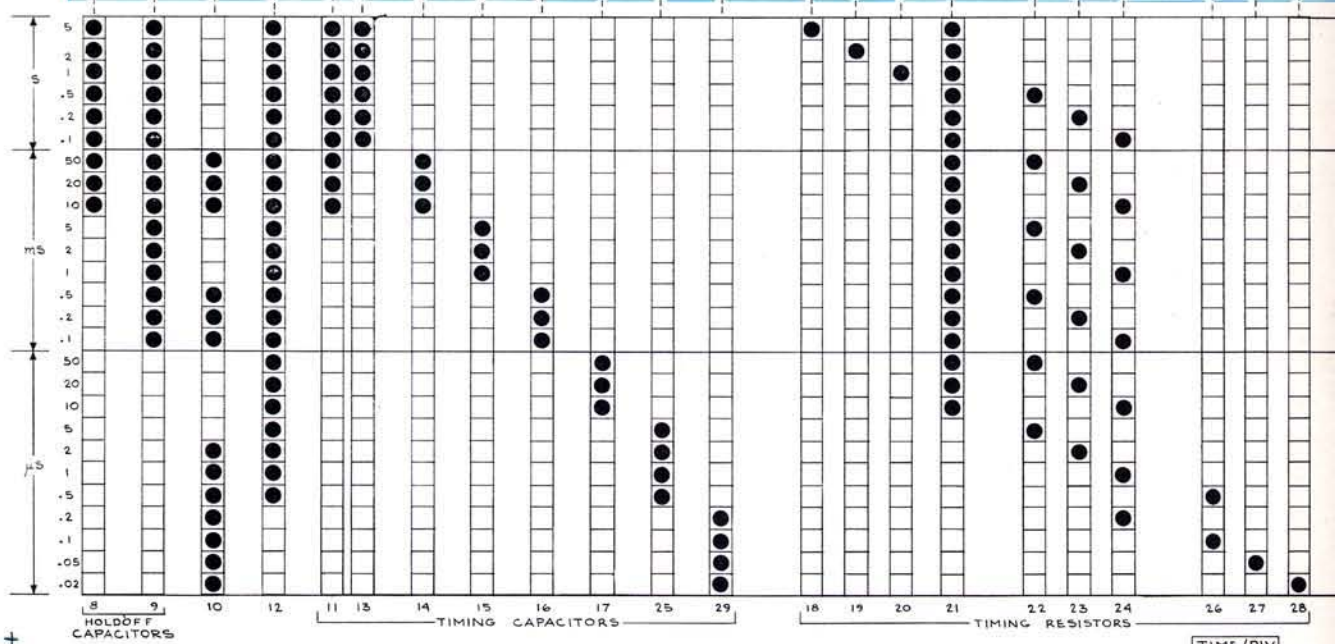
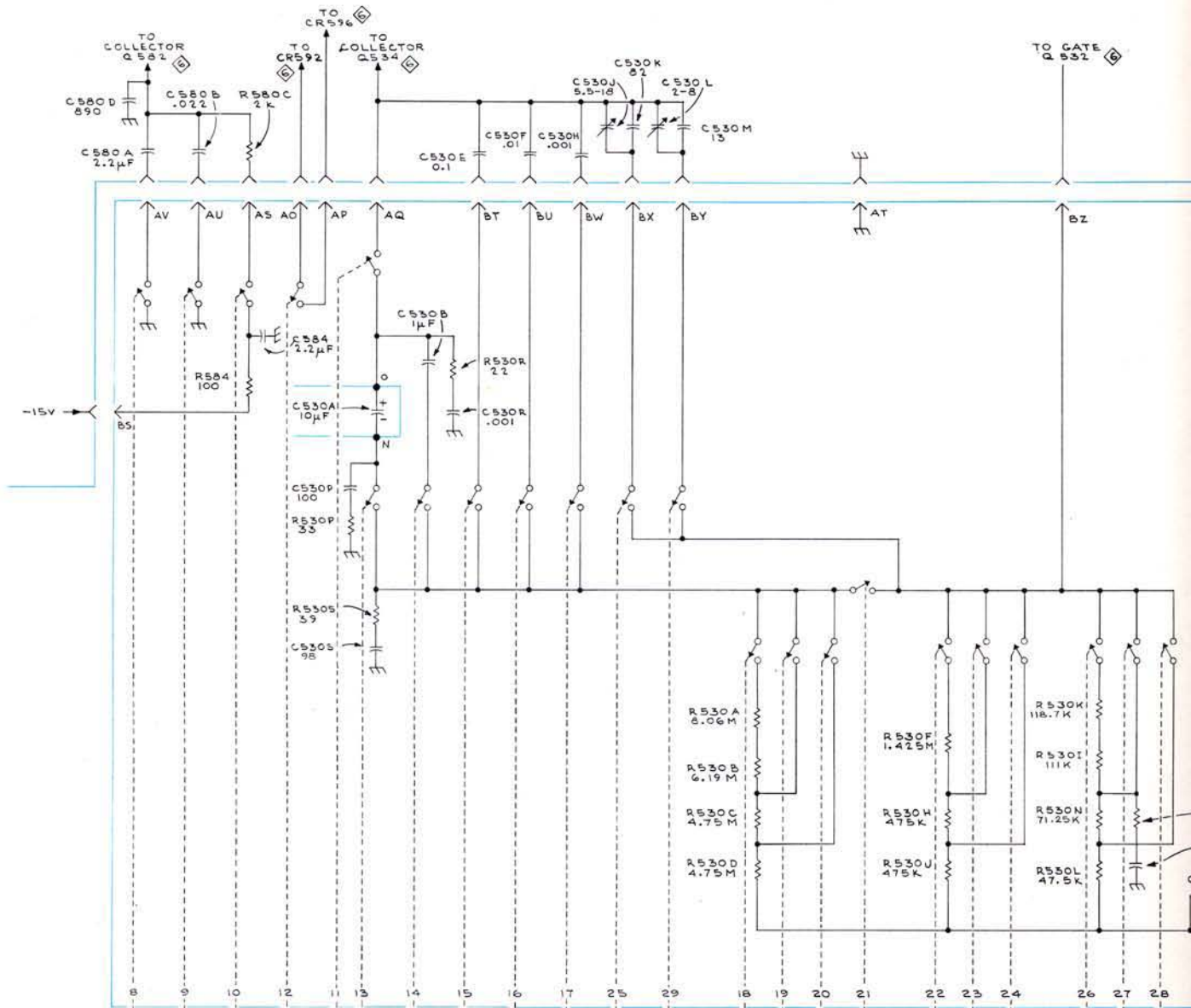

7B71 PLUG-IN

TIME/DIV
550

TO GATE Q 532

PARTIAL TIME-BASE BOARD

- REFERENCE DIAGRAMS
- ◇ TIME-BASE GENERATOR
 - ◇ HORIZONTAL PREAMP
 - ◇ DECOUPLING & OUTPUT CONNECTORS

PARTIAL INTERFACE BOARD

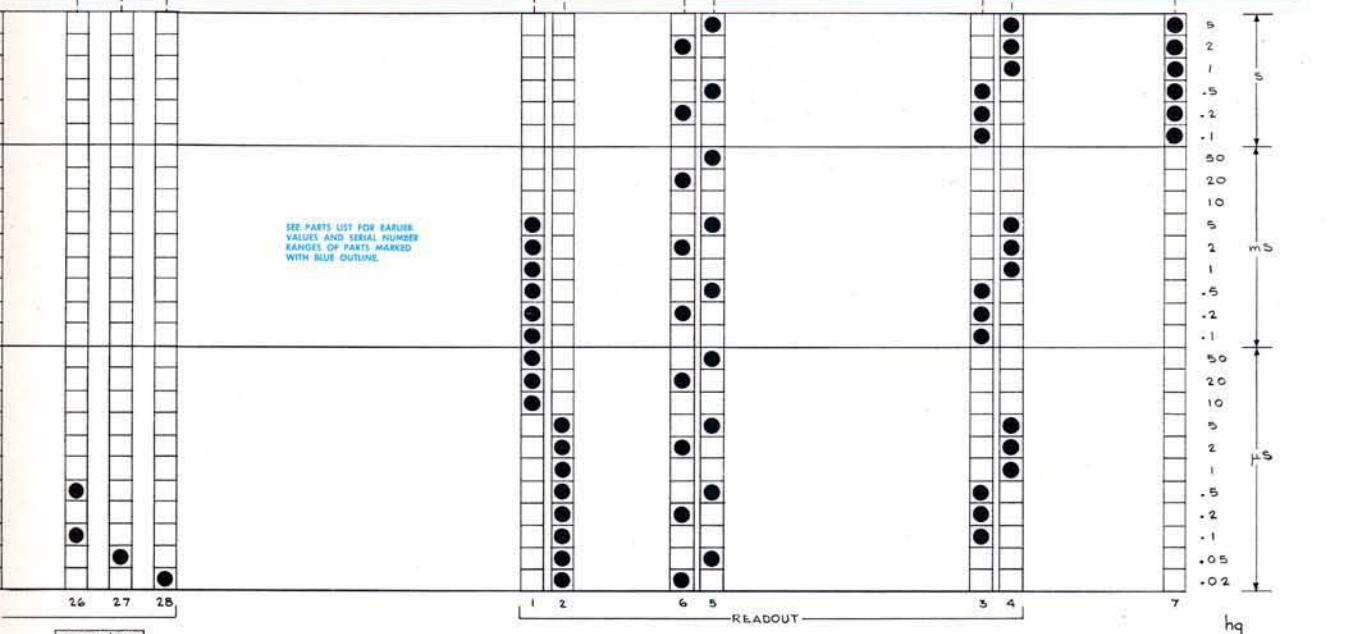
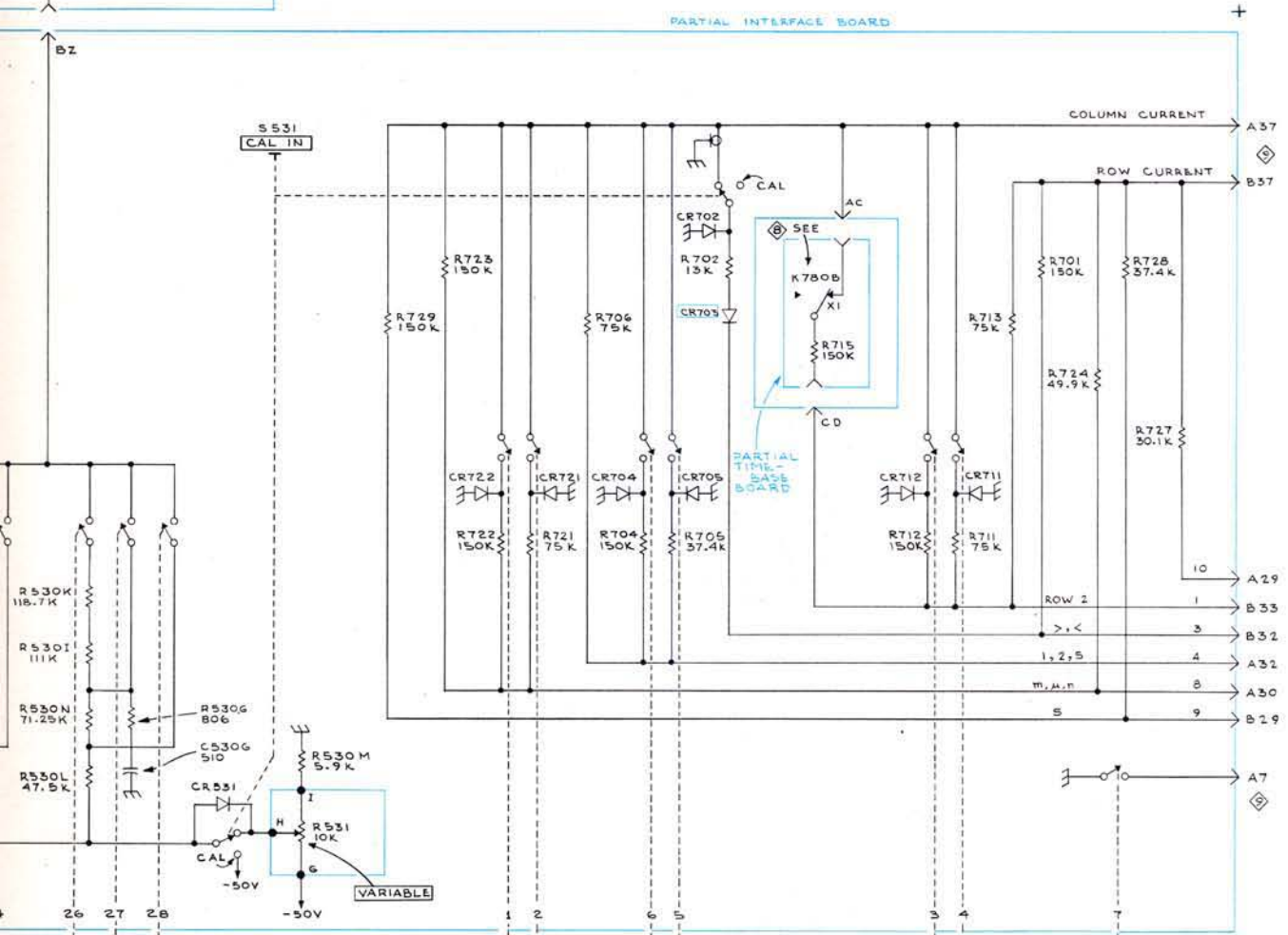

SEE PARTS LIST FOR EARLIER VALUES AND SERIAL NUMBER RANGES OF PARTS MARKED WITH BLUE OUTLINE

TIME/DIV 5 5 30

TIMING SWITCH ◇

TIMING SWITCH

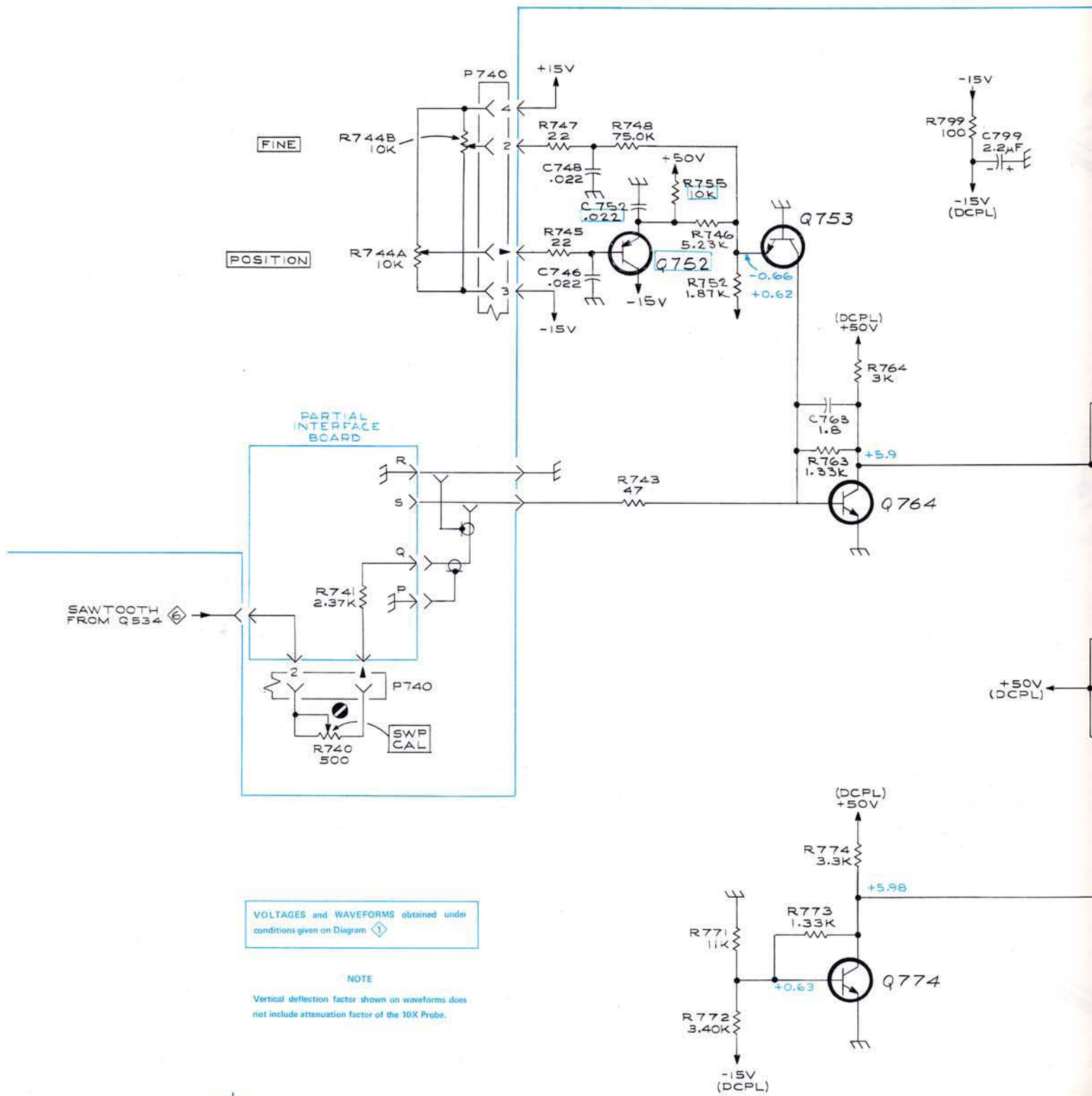

NOTES:

1. SEE PARTS LIST FOR SEMICONDUCTOR TYPES
2. * TRANSISTORS IN SAME TEMP ENVIRONMENT

SEE PARTS LIST FOR EARLIER VALUES AND SERIAL NUMBER RANGES OF PARTS MARKED WITH BLUE OUTLINE.

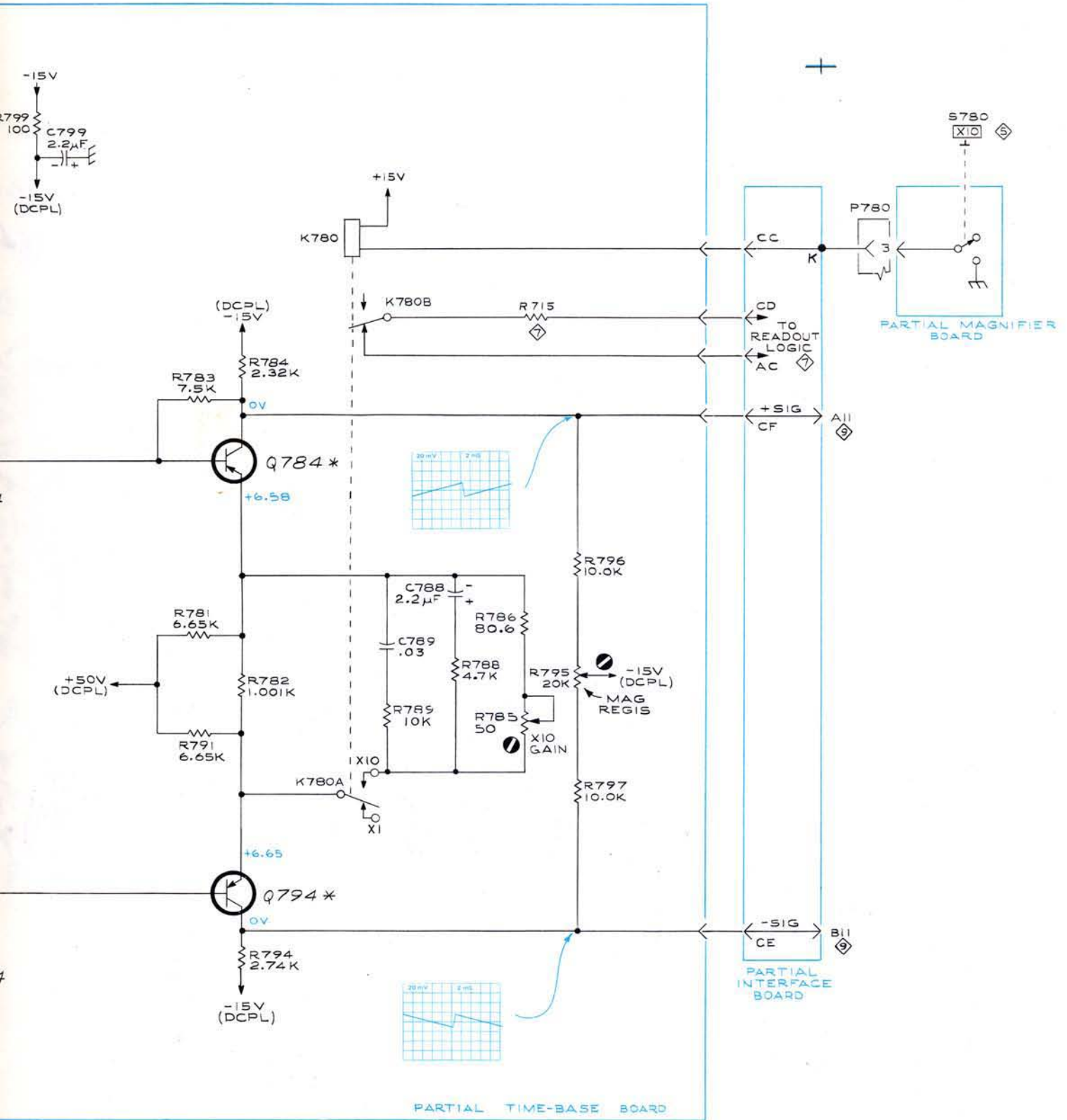

REFERENCE DIAGRAMS

- ⑤ TRIGGERING SWITCHES
- ⑥ TIME-BASE GENERATOR
- ⑦ TIMING SWITCH
- ⑧ DECOUPLING & OUTPUT CONNECTOR

VR5
1170

+

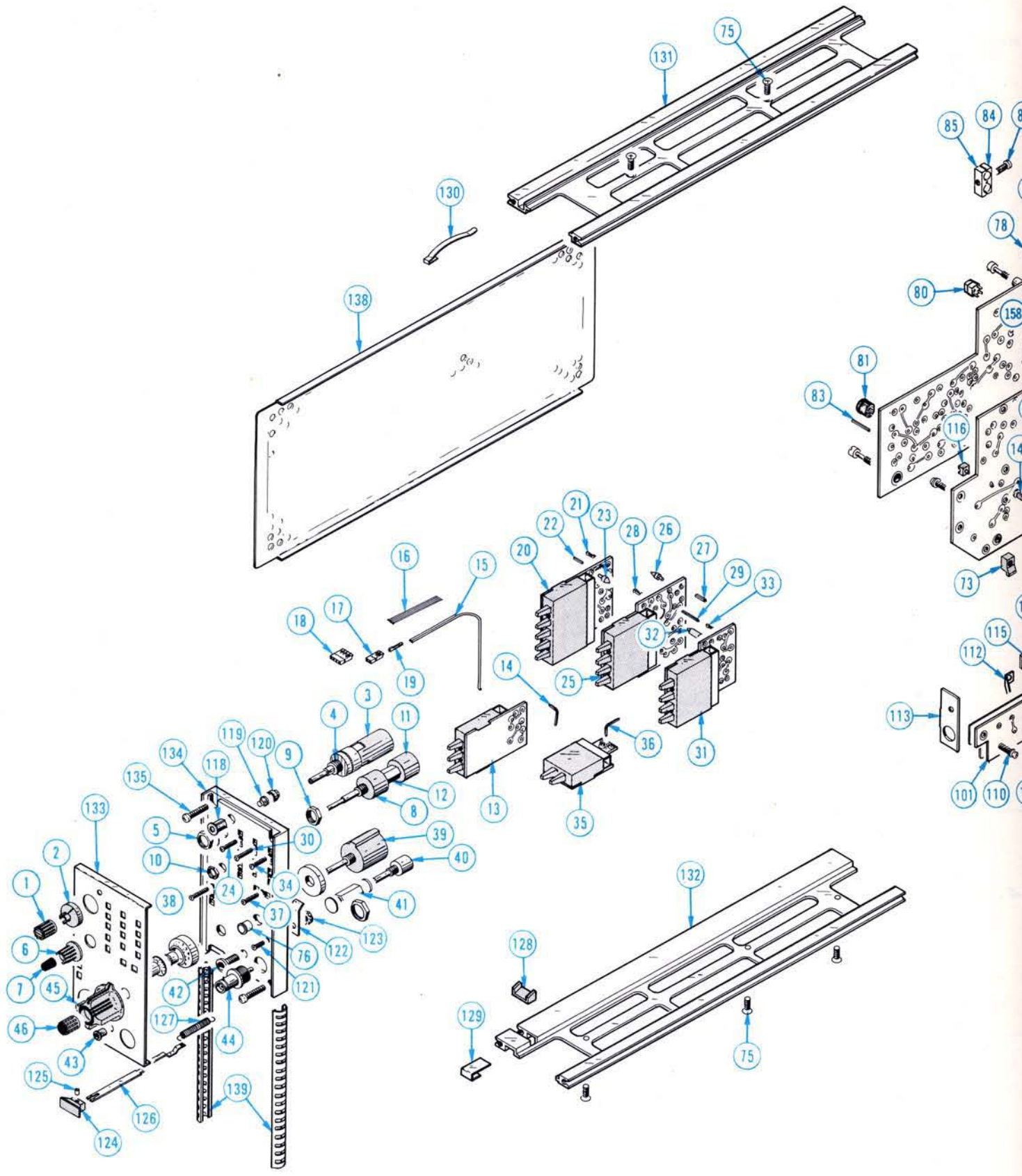

7B71 DELAYING TIME BASE

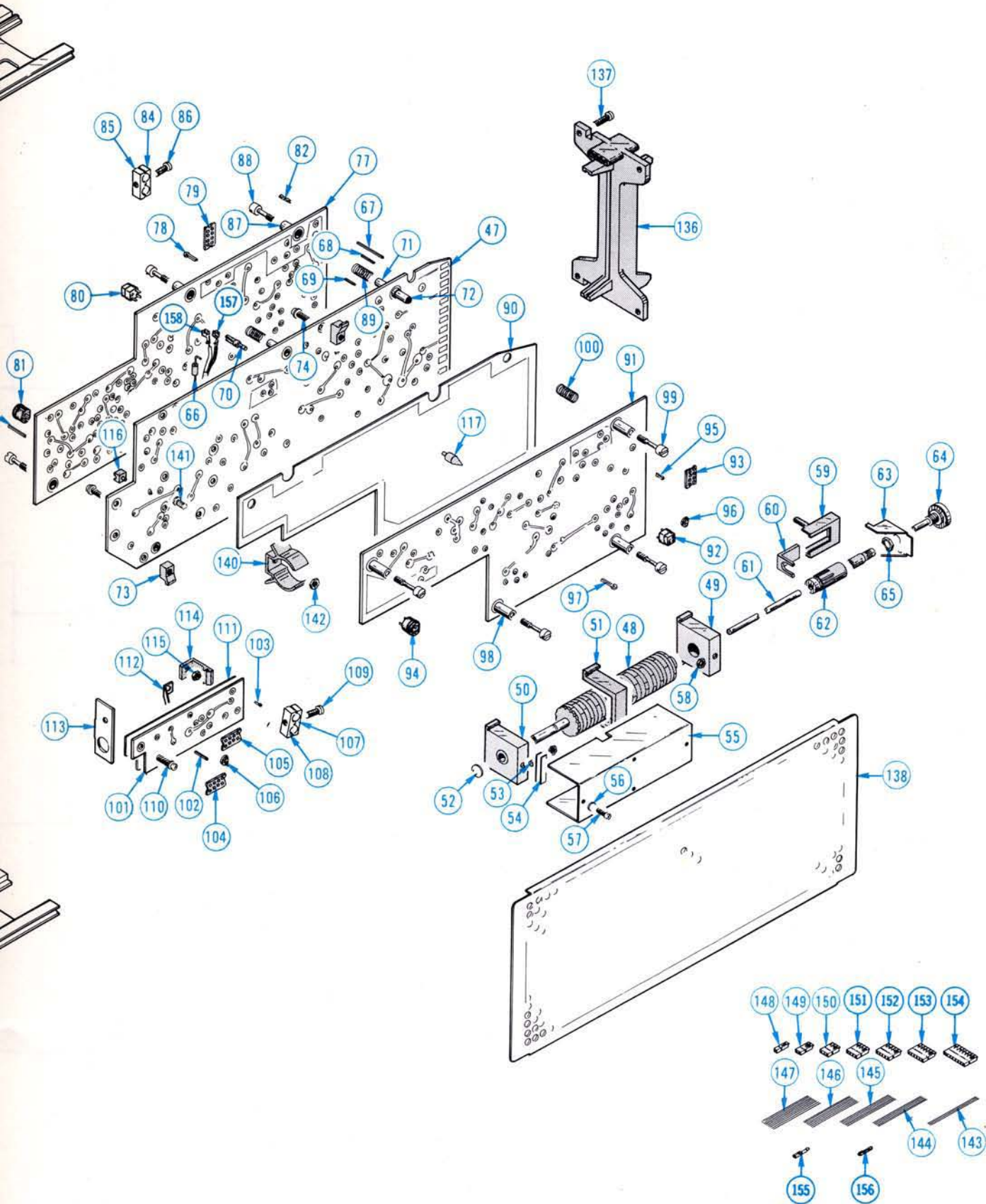

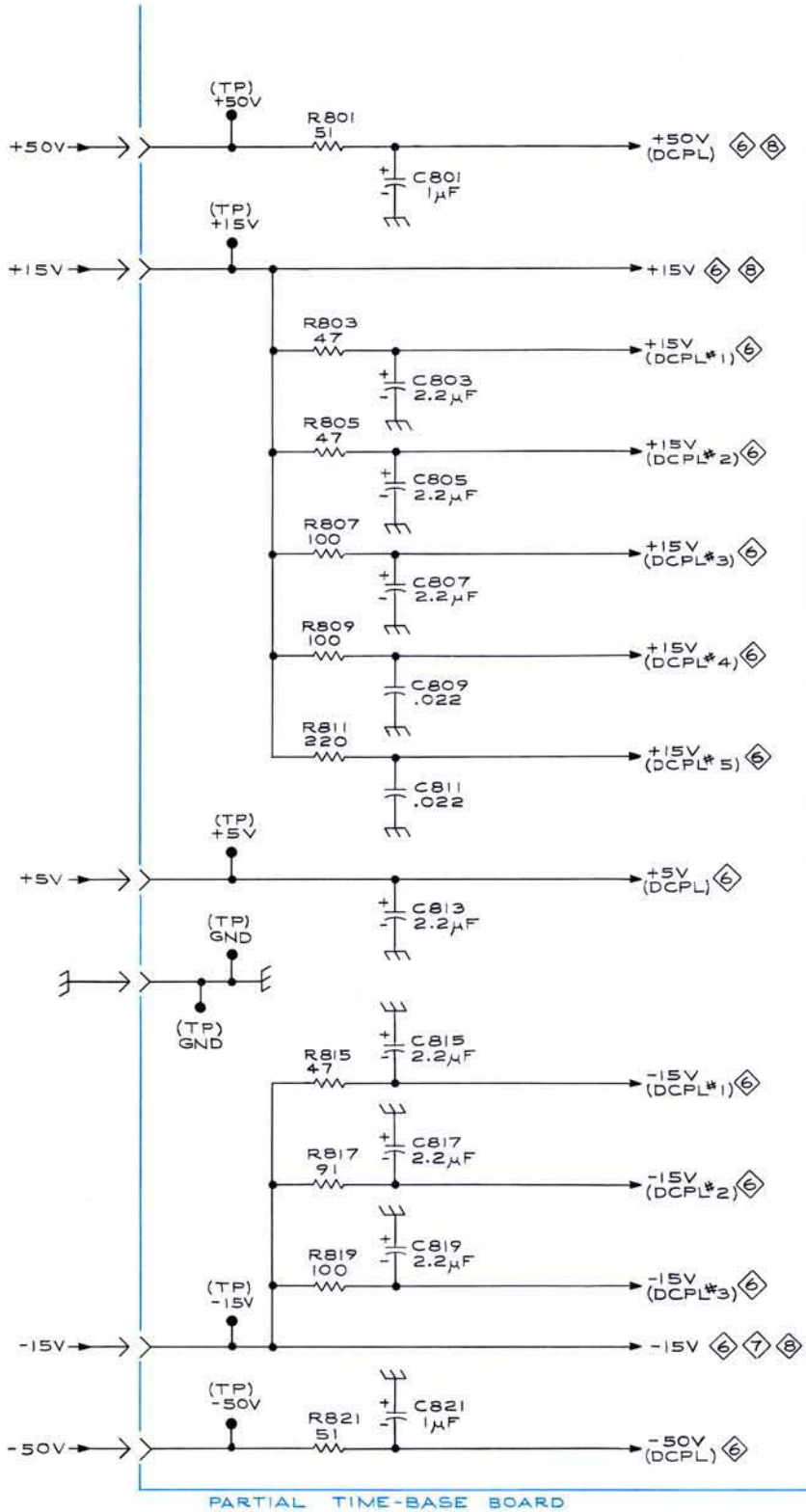

REFERENCE DIAGRAM

- ① TRIGGER INPUT
- ③ PEAK DETECTOR
- ④ TRIGGER GENERATOR
- ⑤ TRIGGERING SWITCHES
- ⑥ TIME-BASE GENERATOR
- ⑦ TIMING SWITCH
- ⑧ HORIZONTAL PREAMP

+

7B71 PLUG-IN

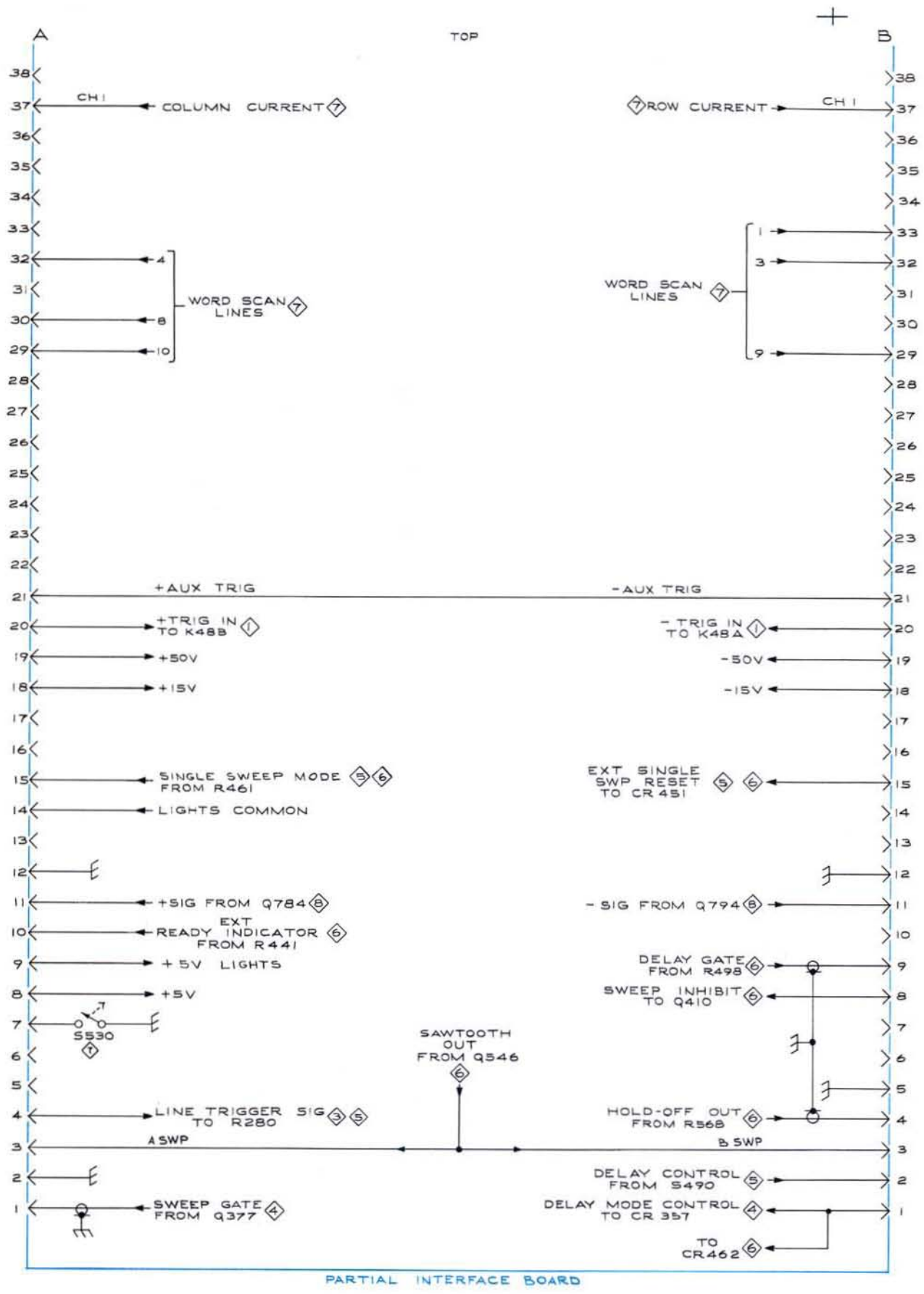

VRS
0270

DECOUPLING & OUTPUT CONNECTOR 9

A1

+

CARTON ASSEMBLY
(Part No. 065-0125-00)

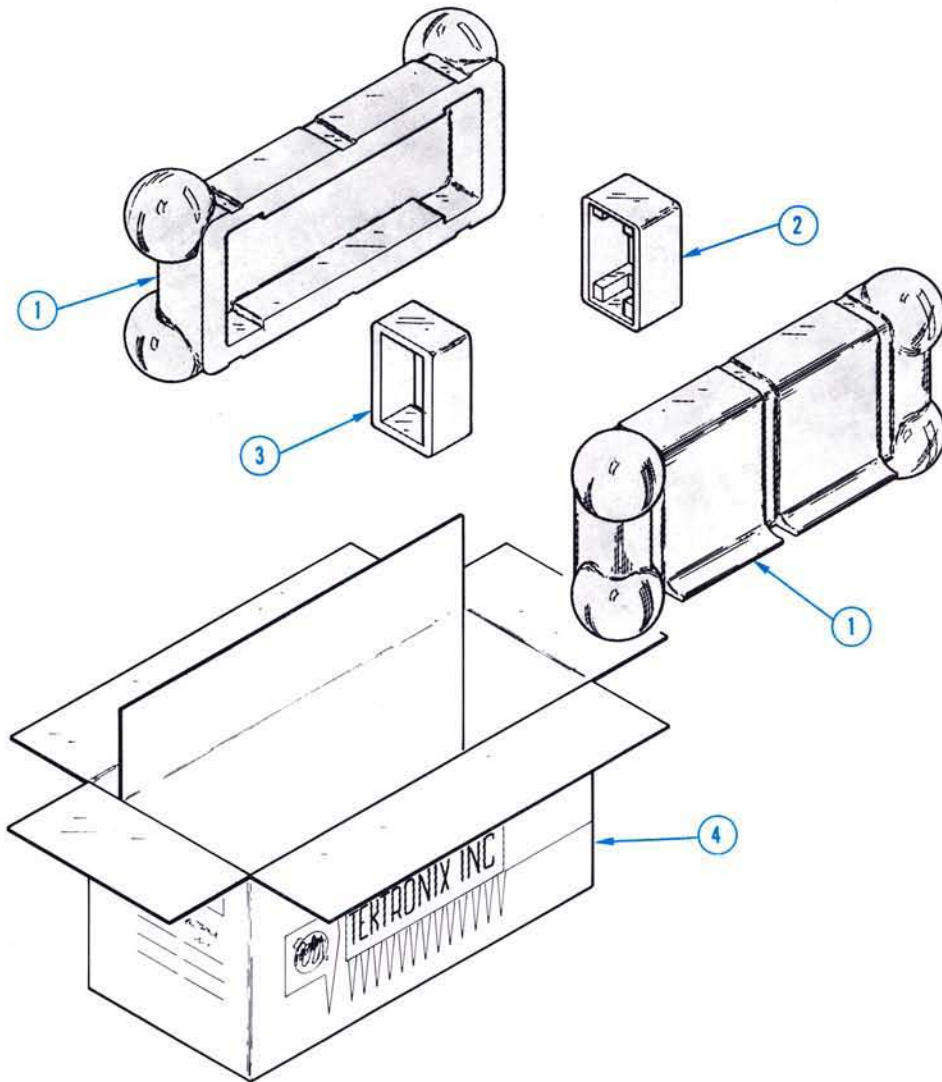

Ⓐ+

Fig. & Index No.	Tektronix Part No.	Serial/Model No. Eff	No. Disc	Q					Description	
				†	y	1	2	3		4
2-	065-0125-00			1						ASSEMBLY, carton assembly includes:
-1	004-0241-00			-						CASE HALF
-2	004-0242-00			1						END CAP, rear
-3	004-0243-00			1						END CAP, front
-4	004-0748-00			1						CARTON

FIGURE AND INDEX NUMBERS

Items in this section are referenced by figure and index numbers to the illustrations which appear either on the back of the diagrams or on pullout pages immediately following the diagrams of the instruction manual.

INDENTATION SYSTEM

This mechanical parts list is indented to indicate item relationships. Following is an example of the indentation system used in the Description column.

Assembly and/or Component
Detail Part of Assembly and/or Component
mounting hardware for Detail Part
Parts of Detail Part
mounting hardware for Parts of Detail Part
mounting hardware for Assembly and/or Component

Mounting hardware always appears in the same indentation as the item it mounts, while the detail parts are indented to the right. Indented items are part of, and included with, the next higher indentation.

Mounting hardware must be purchased separately, unless otherwise specified.

PARTS ORDERING INFORMATION

Replacement parts are available from or through your local Tektronix, Inc. Field Office or representative.

Changes to Tektronix instruments are sometimes made to accommodate improved components as they become available, and to give you the benefit of the latest circuit improvements developed in our engineering department. It is therefore important, when ordering parts, to include the following information in your order: Part number, instrument type or number, serial or model number, and modification number if applicable.

If a part you have ordered has been replaced with a new or improved part, your local Tektronix, Inc. Field Office or representative will contact you concerning any change in part number.

Change information, if any, is located at the rear of this manual.

ABBREVIATIONS AND SYMBOLS

For an explanation of the abbreviations and symbols used in this section, please refer to the page immediately preceding the Electrical Parts List in this instruction manual.

INDEX OF MECHANICAL PARTS ILLUSTRATIONS

Title	Location (reverse side of)
Figure 1 Exploded	Horizontal Preamp Diagram
Figure 2 Repackaging	Decoupling & Output Connector Diagram

SECTION 8

MECHANICAL PARTS LIST

FIGURE 1 EXPLODED

Fig. & Index No.	Tektronix Part No.	Serial/Model Eff	No. Disc	Q					Description	
				t	y	1	2	3		4
1-1	366-1064-00			1						KNOB, gray—LEVEL/SLOPE
	- - - - -			-						knob includes:
	213-0153-00			1						SETSCREW, 5-40 x 0.125 inch, HSS
-2	354-0342-00			1						RING, knob skirt
-3	- - - - -			1						RESISTOR, variable
	- - - - -			1						resistor includes:
-4	214-1235-00			1						DRIVE, turns reduction
	- - - - -			-						mounting hardware: (not included w/resistor)
	210-0978-00			1						WASHER, flat, 0.375 ID x 0.50 inch OD
-5	210-0590-00			1						NUT, hex., 0.375-32 x 0.312 inch
-6	366-1174-00	B010100	B100000	1						KNOB, gray—POSITION
	366-1318-00	B110000		1						KNOB, gray—POSITION
	- - - - -			-						knob includes:
	213-0153-00			1						SETSCREW, 5-40 x 0.125 inch, HSS
-7	366-1173-00	B010100	B100000	1						KNOB, gray—FINE
	366-1319-00	B110000		1						KNOB, gray—FINE
	- - - - -			-						knob includes:
	213-0140-00			1						SETSCREW, 2-56 x 0.093 inch, HSS
-8	- - - - -			1						RESISTOR, variable
	- - - - -			-						mounting hardware: (not included w/resistor)
-9	210-0465-00			1						NUT, hex., 0.25-32 x 0.375 inch
-10	210-0583-00			1						NUT, hex., 0.25-32 x 0.312 inch
-11	- - - - -			1						RESISTOR, variable
	- - - - -			-						mounting hardware: (not included w/resistor)
-12	220-0420-00			1						NUT, hex., adapter, 0.50 inch long
-13	670-1103-00			1						CIRCUIT BOARD ASSEMBLY—B DELAY MODE
	- - - - -			-						circuit board assembly includes:
-14	131-0589-00			7						TERMINAL, pin 0.50 inch long
-15	175-0825-00			ft						WIRE, electrical, 2 wire ribbon, 4.25 inches long
-16	175-0827-00			ft						WIRE, electrical, 4 wire ribbon, 2.50 inches long
-17	352-0169-00			1						HOLDER, terminal connector, 2 wire
-18	352-0162-00			1						HOLDER, terminal connector, 4 wire
-19	131-0707-00			6						CONNECTOR, terminal
	380-0154-00			1						HOUSING, light, 3 button
	- - - - -			-						mounting hardware: (not included w/housing)
	213-0181-00			1						SCREW, thread forming, #2 x 0.375 inch, PHS
	- - - - -			-						mounting hardware: (not included w/circuit board assembly)
	211-0156-00			1						SCREW, 1-72 x 0.25 inch, 82° csk, FHS

FIGURE 1 EXPLODED (cont)

Fig. & Index No.	Tektronix Part No.	Serial/Model No. Eff	No. Disc	Q t y	Description	1 2 3 4 5				
1-20	670-1143-00	B010100	B029999	1	CIRCUIT BOARD ASSEMBLY—MODE (Triggering)					
	670-1143-01	B030000		1	CIRCUIT BOARD ASSEMBLY—MODE (Triggering)					
	- - - - -			-	circuit board assembly includes:					
-21	136-0263-01			20	SOCKET, pin terminal					
-22	131-0608-00			12	TERMINAL, pin, 0.365 inch long					
-23	386-1635-00			1	SUPPORT, circuit board, for 0.118 inch board height					
	380-0156-01			1	HOUSING, light, 5 button					
	- - - - -			-	mounting hardware: (not included w/housing)					
	213-0181-00			1	SCREW, thread forming, #2 x 0.375 inch, PHS					
	- - - - -			-	mounting hardware: (not included w/circuit board assembly)					
-24	211-0156-00			2	SCREW, 1-72 x 0.25 inch, 82° csk, FHS					
-25	670-1146-00	B010100	B029999	1	CIRCUIT BOARD ASSEMBLY—COUPLING (Triggering)					
	670-1146-01	B030000		1	CIRCUIT BOARD ASSEMBLY—COUPLING (Triggering)					
	- - - - -			-	circuit board assembly includes:					
-26	386-1557-00			2	SUPPORT, circuit board, for 0.28 inch board height					
-27	131-0608-00			4	TERMINAL, pin, 0.365 inch long					
-28	136-0327-00			13	SOCKET, pin, terminal					
-29	131-0590-00			10	TERMINAL, pin, 0.71 inch long					
	380-0155-00			1	HOUSING, light, 4 button					
	- - - - -			-	mounting hardware: (not included w/housing)					
	213-0181-00			1	SCREW, thread forming, #2 x 0.375 inch, PHS					
	- - - - -			-	mounting hardware: (not included w/circuit board assembly)					
-30	211-0156-00			2	SCREW, 1-72 x 0.25 inch, 82° csk, FHS					
-31	670-1145-00	B010100	B099999	1	CIRCUIT BOARD ASSEMBLY—SOURCE (Triggering)					
	670-1145-01	B100000		1	CIRCUIT BOARD ASSEMBLY—SOURCE (Triggering)					
	- - - - -			-	circuit board assembly includes:					
-32	386-1559-00			2	SUPPORT, circuit board, 0.47 inch board height					
-33	136-0327-00			10	SOCKET, pin, terminal					
	380-0155-00			1	HOUSING, light, 4 button					
	- - - - -			-	mounting hardware: (not included w/housing)					
	213-0181-00			1	SCREW, thread forming, #2 x 0.375 inch, PHS					
	- - - - -			-	mounting hardware: (not included w/circuit board assembly)					
-34	211-0156-00			2	SCREW, 1-72 x 0.25 inch, 82° csk, FHS					
-35	670-1107-00	B010100	B099999	1	CIRCUIT BOARD ASSEMBLY—MAGNIFIER					
	670-1107-01	B100000		1	CIRCUIT BOARD ASSEMBLY—MAGNIFIER					
	- - - - -			-	circuit board assembly includes:					
-36	131-0589-00			6	TERMINAL, pin, 0.50 inch long					
	380-0148-00			1	HOUSING, light, 2 button					
	- - - - -			-	mounting hardware: (not included w/housing)					
	213-0181-00			1	SCREW, thread forming, #2 x 0.375 inch, PHS					
	- - - - -			-	mounting hardware: (not included w/circuit board assembly)					
-37	211-0156-00			1	SCREW, 1-72 x 0.25 inch, 82° csk, FHS					
-38	331-0247-00			1	DIAL, control—DELAY TIME MULT					
-39	- - - - -			1	RESISTOR, variable, w/hardware					
-40	- - - - -			1	RESISTOR, variable					
	- - - - -			-	mounting hardware: (not included w/resistor)					
	210-0046-00			2	WASHER, lock, internal, 0.261 ID x 0.40 inch OD					
-41	129-0252-00			1	POST, metallic, 0.45 x 0.312 hex., 0.25-32 threaded					
-42	358-0409-00			1	BUSHING, machine thread					

FIGURE 1 EXPLODED (cont)

Fig. & Index No.	Tektronix Part No.	Serial/Model No.		Q t Y	Description
		Eff	Disc		
1-43	358-0301-02			1	BUSHING, sleeve, front panel trim
-44	131-0350-02			1	CONNECTOR, receptacle, electrical, BNC
-45	366-1103-00			1	KNOB, gray—TIME/DIV
	213-0020-00			-	knob includes:
				2	SETSCREW, 6-32 x 0.125 inch, HSS
-46	366-1166-00			1	KNOB, red—VARIABLE (CAL IN)
	213-0153-00			-	knob includes:
				1	SETSCREW, 5-40 x 0.125 inch, HSS
-47	670-1142-00	B010100	B119999	1	CIRCUIT BOARD ASSEMBLY—INTERFACE
	670-1142-01	B120000		1	CIRCUIT BOARD ASSEMBLY—INTERFACE
				-	circuit board assembly includes:
	388-1426-00			1	CIRCUIT BOARD
-48	105-0122-00			1	DRUM, cam switch—TIME/DIV
-49	401-0056-00			1	BEARING, rear
				-	mounting hardware: (not included w/bearing)
	211-0116-00			2	SCREW, sems, 4-40 x 0.312 inch, PHB
	210-0406-00			2	NUT, hex., 4-40 x 0.188 inch
-50	401-0057-00			1	BEARING, front
				-	mounting hardware: (not included w/bearing)
	211-0116-00			2	SCREW, sems, 4-40 x 0.312 inch, PHB
	210-0405-00			2	NUT, hex., 4-40 x 0.188 inch
-51	407-0653-00			1	BRACKET, support
				-	mounting hardware: (not included w/bracket)
	211-0116-00			2	SCREW, sems, 4-40 x 0.312 inch, PHB
	210-0406-00			2	NUT, hex., 4-40 x 0.188 inch
-52	354-0219-00			1	RING, retainer
-53	214-1127-00			1	ROLLER, detent
-54	214-1139-00 ¹			-	SPRING, flat, gold
	214-1139-02 ¹			-	SPRING, flat, green
	214-1139-03 ¹			-	SPRING, flat, red
-55	200-0963-00			1	COVER, cam switch
				-	mounting hardware: (not included w/cover)
-56	210-0001-00			4	WASHER, lock, internal, #2
-57	211-0079-00			4	SCREW, 2-56 x 0.188 inch, PHS
-58	210-0405-00			4	NUT, hex., 2-56 x 0.188 inch
-59	351-0180-00			1	GUIDE, actuator
-60	214-1136-00			1	SLIDE, actuator
-61	384-0490-00			1	SHAFT, extension, 5.93 inches long
-62	214-1190-00			1	EXTENDER-RETRACTOR knob
-63	407-0553-00			1	BRACKET, variable resistor
-64				1	RESISTOR, variable
				-	mounting hardware: (not included w/resistor)
-65	210-0583-00			1	NUT, hex., 0.25-32 x 0.312 inch
-66	131-0566-00			26	LINK, terminal connector
-67	131-0593-00			8	TERMINAL, pin, 1.15 inches long
-68	131-0590-00			85	TERMINAL, pin, 0.67 inch long
-69	131-0608-00			12	TERMINAL, pin, 0.365 inch long

¹Replace only with part bearing the same color as the original part in your instrument.

FIGURE 1 EXPLODED (cont)

Fig. & Index No.	Tektronix Part No.	Serial/Model Eff	No. Disc	Q † y	Description				
					1	2	3	4	5
1-70	351-0155-00			12	GUIDE, terminal lead				
-71	351-0185-00			4	GUIDE-POST, lock				
-72	351-0188-00			6	GUIDE-POST, lock				
-	-			-	mounting hardware: (not included w/circuit board assembly)				
-73	220-0547-01			5	NUT BLOCK				
-74	211-0116-00			5	SCREW, sems, 4-40 x 0.312 inch, PHB				
-75	211-0105-00			5	SCREW, 4-40 x 0.188 inch, 100° csk, FHS				
-76	348-0067-00			1	GROMMET, plastic, 0.312 inch diameter				
-77	670-1169-00	B010100	B069999	1	CIRCUIT BOARD ASSEMBLY—TIME BASE				
	670-1169-01	B070000	B089999	1	CIRCUIT BOARD ASSEMBLY—TIME BASE				
	670-1169-02	B090000	B129999	1	CIRCUIT BOARD ASSEMBLY—TIME BASE				
	670-1169-03	B130000		1	CIRCUIT BOARD ASSEMBLY—TIME BASE				
-	-			-	circuit board assembly includes:				
	388-1479-00			1	CIRCUIT BOARD				
-78	214-0579-00			24	PIN, test point				
-79	136-0337-00			1	SOCKET, relay, 8 pin				
-80	136-0220-00			30	SOCKET, transistor, 3 pin, square				
-81	136-0235-00			6	SOCKET, transistor, 6 pin				
-82	136-0263-03			42	SOCKET, pin terminal				
-83	131-0608-00			7	TERMINAL, pin, 0.365 inch long				
-84	200-0945-00			1	COVER, half, transistor, temp stabilizer, dual				
-85	200-0945-01			1	COVER, half, transistor, temp stabilizer, dual, threaded				
-86	211-0062-00			1	SCREW, 2-56 x 0.312 inch, RHS				
-87	361-0238-00			5	SPACER, sleeve				
-	-			-	mounting hardware: (not included w/circuit board assembly)				
-88	211-0155-00			5	SCREW, 4-40 x 0.375 inch, relieved shank				
-89	214-1140-00			5	SPRING, helical compression				
-90	388-1431-00			1	CIRCUIT BOARD, shield (Triggering)				
	388-1639-00			1	CIRCUIT BOARD, shield (TIME BASE, not shown)				
-91	670-1141-00	B010100	B019999	1	CIRCUIT BOARD ASSEMBLY—TRIGGER				
	670-1141-01	B020000	B029999	1	CIRCUIT BOARD ASSEMBLY—TRIGGER				
	670-1141-02	B030000	B129999	1	CIRCUIT BOARD ASSEMBLY—TRIGGER				
	670-1144-03	B130000		1	CIRCUIT BOARD ASSEMBLY—TRIGGER				
-	-			-	circuit board assembly includes:				
	388-1425-00			1	CIRCUIT BOARD				
	200-0495-00	XB040000		1	COVER, half, transistor, temp stabilizer, dual				
	200-0495-01	XB040000		1	COVER, half, transistor, temp stabilizer, dual, threaded				
-92	136-0220-00			8	SOCKET, transistor, 3 pin, square				
-93	136-0337-00			3	SOCKET, relay, 8 pin				
-94	136-0237-00			2	SOCKET, transistor, 8 pin				
-95	136-0263-00			27	SOCKET, pin terminal				
-96	136-0350-00			32	SOCKET, transistor, 3 pin				
-97	214-0579-00			11	PIN, test point				
-98	361-0238-00			5	SPACER, sleeve				
-	-			-	mounting hardware: (not included w/circuit board assembly)				
-99	211-0155-00			5	SCREW, 4-40 x 0.375 inch, relieved shank				
-100	214-1140-00			5	SPRING, helical compression				
-101	670-1144-00			1	CIRCUIT BOARD ASSEMBLY—EXTERNAL INPUT				
-	-			-	circuit board assembly includes:				
	388-1428-00			1	CIRCUIT BOARD				
-102	131-0608-00			6	TERMINAL, pin, 0.365 inch				
-103	136-0252-01			6	SOCKET, pin connector, 0.178 inch long				
-104	136-0336-00			1	SOCKET, relay, 5 pin				
-105	136-0337-00			1	SOCKET, relay, 8 pin				

FIGURE 1 EXPLODED (cont)

Fig. & Index No.	Tektronix Part No.	Serial/Model No.		Q † Y	Description
		Eff	Disc		
-106	136-0350-00			2	SOCKET, transistor
-107	200-0945-00			1	COVER, half, transistor, temp stabilizer, dual
-108	200-0945-01			1	COVER, half, transistor, temp stabilizer, dual, threaded
-109	211-0062-00			1	SCREW, 2-56 x 0.312 inch, RHS
	- - - - -			-	mounting hardware: (not included w/circuit board assembly)
-110	211-0116-00			1	SCREW, sems, 4-40 x 0.312 inch, PHB
-111	337-1270-00			1	SHIELD
-112	131-0907-00			1	CONTACT, electrical ground
-113	407-0748-00			1	BRACKET
-114	344-0131-00			1	CLIP, circuit board
	- - - - -			-	mounting hardware: (not included w/clip)
	211-0116-00			1	SCREW, sems, 4-40 x 0.312 inch, PHB
-115	210-0406-00			1	NUT, hex., 4-40 x 0.188 inch
-116	352-0213-00			1	HOLDER, cable
-117	386-1657-00			9	SUPPORT, circuit board, for 0.185 inch board height
-118	352-0157-00			1	HOLDER, lamp
-119	378-0602-00			1	LENS, lamp
-120	200-0935-00			1	CAP, lamp holder
-121	131-0664-00			1	CONTACT, electrical, shaft ground
	- - - - -			-	mounting hardware: (not included w/contact)
-122	211-0101-00			1	SCREW, 4-40 x 0.25 inch, 100° csk, FHS
-123	210-0586-00			1	NUT, keps, 4-40 x 0.25 inch
-124	366-1058-01			1	KNOB, latch
-125	214-1095-00			1	PIN, spring, split
-126	105-0076-00			1	RELEASE BAR, latch
-127	214-1280-00			1	SPRING, helical compression
-128	105-0075-00			1	BODY, latch
-129	214-1054-00			1	SPRING, flat, latch detent
-130	214-1061-00			1	SPRING, flat, sliding ground
-131	426-0505-04			1	FRAME SECTION, top
-132	426-0499-04			1	FRAME SECTION, bottom
-133	333-1261-00			1	PANEL, front
-134	386-1447-11			1	SUBPANEL, front
	- - - - -			-	mounting hardware: (not included w/subpanel)
-135	213-0192-00			4	SCREW, thread forming, 6-32 x 0.50 inch, Fil HS
-136	386-1402-00			1	PANEL, rear
	- - - - -			-	mounting hardware: (not included w/panel)
-137	213-0192-00			4	SCREW, thread forming, 6-32 x 0.50 inch, Fil HS
	361-0326-00			1	SPACER, sleeve, 0.10 inch
-138	337-1064-00			2	SHIELD, electrical
-139	348-0235-00			2	SHIELDING GASKET
-140	344-0189-00			2	CLIP, capacitor
	- - - - -			-	mounting hardware for each: (not included w/clip)
-141	211-0601-00			1	SCREW, sems, 6-32 x 0.312 inch, PHB
-142	210-0407-00			1	NUT, hex., 6-32 x 0.25 inch

FIGURE 1 EXPLODED (cont)

Fig. & Index No.	Tektronix Part No.	Serial/Model Eff	No. Disc	Q					Description	
				t	Y	1	2	3		4
1-143	175-0825-00			ft						WIRE, electrical, 2 wire ribbon, 6.25 inches long
-144	175-0827-00			ft						WIRE, electrical, 4 wire ribbon, 11.50 inches long
-145	175-0828-00			ft						WIRE, electrical, 5 wire ribbon, 2.50 inches long
-146	175-0829-00			ft						WIRE, electrical, 6 wire ribbon, 10 inches long
-147	175-0831-00			ft						WIRE, electrical, 8 wire ribbon, 4 inches long
-148	352-0171-00			6						HOLDER, terminal connector, 1 wire
-149	352-0169-00			2						HOLDER, terminal connector, 2 wire
-150	352-0161-00			1						HOLDER, terminal connector, 3 wire
-151	352-0162-00			2						HOLDER, terminal connector, 4 wire
-152	352-0163-00			2						HOLDER, terminal connector, 5 wire
-153	352-0164-00			1						HOLDER, terminal connector, 6 wire
-154	352-0166-00			1						HOLDER, terminal connector, 8 wire
-155	131-0707-00			49						CONNECTOR, terminal, large
-156	131-0708-00			1						CONNECTOR, terminal, small
-157	131-0755-00			6						CONNECTOR, terminal
-158	131-0512-00			6						CONNECTOR, terminal, coaxial cable

STANDARD ACCESSORIES

070-0983-00	1	MANUAL, instruction (not shown)
-------------	---	---------------------------------

MANUAL CHANGE INFORMATION

At Tektronix, we continually strive to keep up with latest electronic developments by adding circuit and component improvements to our instruments as soon as they are developed and tested.

Sometimes, due to printing and shipping requirements, we can't get these changes immediately into printed manuals. Hence, your manual may contain new change information on following pages.

A single change may affect several sections. Sections of the manual are often printed at different times, so some of the information on the change pages may already be in your manual. Since the change information sheets are carried in the manual until ALL changes are permanently entered, some duplication may occur. If no such change pages appear in this section, your manual is correct as printed.

Scans By *Artek Media*

Artek Media
1042 Plummer Cir. SW
Rochester, MN 55902

www.artekmedia.com

"High resolution scans of obsolete technical manuals"

If your looking for a quality scanned technical manual in PDF format please visit our WEB site at www.artekmedia.com or drop us an email at manuals@artekmedia.com and we will be happy to email you a current list of the manuals we have available.

If you don't see the manual you need on the list drop us a line anyway we may still be able to point you to other sources. If you have an existing manual you would like scanned please write for details, This can often be done very reasonably in consideration for adding your manual to our library.

Typically the scans in our manuals are done as follows;

- 1) Typed text pages are typically scanned in black and white at 300 dpi.
- 2) Photo pages are typically scanned in gray scale mode at 600 dpi
- 3) Schematic diagram pages are typically scanned in black and white at 600 dpi unless the original manual had colored high lighting (as is the case for some 70's vintage Tektronix manuals).

If you purchased this manual from us (typically through our Ebay name of ArtekMedia) thank you very much. If you received this from a well-meaning "friend" for free we would appreciate your treating this much like you would "share ware". By that we mean a donation of at least \$5-10 per manual is appreciated in recognition of the time (a manual can take as much as 40 hours to reproduce, book, link etc.), energy and quality of effort that went into preserving this manual. Donations via PayPal go to: manuals@artekmedia.com or can be mailed to us the address above.

Thanks



Dave & Lynn Henderson
Artek Media