

# 7T11A

## SAMPLING SWEEP UNIT

*Please Check for  
CHANGE INFORMATION  
at the Rear of This Manual*

# Scans By *Artek Media*

Artek Media  
1042 Plummer Cir. SW  
Rochester, MN 55902

[www.artekmedia.com](http://www.artekmedia.com)

"High resolution scans of obsolete technical manuals"

If your looking for a quality scanned technical manual in PDF format please visit our WEB site at [www.artekmedia.com](http://www.artekmedia.com) or drop us an email at [manuals@artekmedia.com](mailto:manuals@artekmedia.com) and we will be happy to email you a current list of the manuals we have available.

If you don't see the manual you need on the list drop us a line anyway we may still be able to point you to other sources. If you have an existing manual you would like scanned please write for details, This can often be done very reasonably in consideration for adding your manual to our library.

Typically the scans in our manuals are done as follows;

- 1) Typed text pages are typically scanned in black and white at 300 dpi.
- 2) Photo pages are typically scanned in gray scale mode at 600 dpi
- 3) Schematic diagram pages are typically scanned in black and white at 600 dpi unless the original manual had colored high lighting (as is the case for some 70's vintage Tektronix manuals).

If you purchased this manual from us (typically through our Ebay name of ArtekMedia) thank you very much. If you received this from a well-meaning "friend" for free we would appreciate your treating this much like you would "share ware". By that we mean a donation of at least \$5-10 per manual is appreciated in recognition of the time (a manual can take as much as 40 hours to reproduce, book, link etc.), energy and quality of effort that went into preserving this manual. Donations via PayPal go to: [manuals@artekmedia.com](mailto:manuals@artekmedia.com) or can be mailed to us the address above.

Thanks

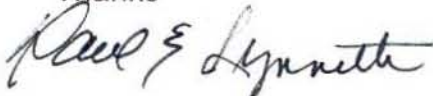

Dave & Lynn Henderson  
Artek Media

Copyright © 1986 Tektronix, Inc. All rights reserved.  
Contents of this publication may not be reproduced in any  
form without the written permission of Tektronix, Inc.

Products of Tektronix, Inc. and its subsidiaries are covered  
by U.S. and foreign patents and/or pending patents.

TEKTRONIX, TEK, SCOPE-MOBILE, and  are  
registered trademarks of Tektronix, Inc. TELEQUIPMENT  
is a registered trademark of Tektronix U.K. Limited.

Printed in U.S.A. Specification and price change privileges  
are reserved.

### INSTRUMENT SERIAL NUMBERS

Each instrument has a serial number on a panel insert, tag,  
or stamped on the chassis. The first number or letter  
designates the country of manufacture. The last five digits  
of the serial number are assigned sequentially and are  
unique to each instrument. Those manufactured in the  
United States have six unique digits. The country of  
manufacture is identified as follows:

B000000	Tektronix, Inc., Beaverton, Oregon, USA
100000	Tektronix Guernsey, Ltd., Channel Islands
200000	Tektronix United Kingdom, Ltd., London
300000	Sony/Tektronix, Japan
700000	Tektronix Holland, NV, Heerenveen, The Netherlands

# TABLE OF CONTENTS

	PAGE		PAGE
LIST OF ILLUSTRATIONS .....	iii	<b>SECTION 3 - THEORY OF OPERATION</b>	
LIST OF TABLES .....	v	Introduction .....	3-1
OPERATORS SAFETY SUMMARY .....	vi	<b>CIRCUIT THEORY</b> .....	3-1
SERVICE SAFETY SUMMARY .....	vii	<b>REAL-TIME SAMPLING</b> .....	3-1
<b>SECTION 1 - SPECIFICATION</b>		General .....	3-1
General Information .....	1-1	Staircase Ramp Output of the Horizontal	
Instrument Features .....	1-1	Memory .....	3-2
Characteristics .....	1-1	Lead Time Real-Time Sampling .....	3-3
<b>SECTION 2 - OPERATING INSTRUCTIONS</b>		Samples/Division Using Real-Time	
General Information .....	2-1	Sampling .....	3-4
Installing the 7T11A in the Oscilloscope .....	2-1	Summary of Real-Time Basic Block	
7T11A Horizontal Gain .....	2-1	Diagram .....	3-4
TIME/DIV Readout .....	2-4	Additional Real-Time Circuits .....	3-5
<b>FRONT PANEL CONTROLS AND CONNECTORS</b> ....	2-4	Controls Affecting Timing and Delay .....	3-6
<b>OPERATORS CHECKOUT PROCEDURE</b> .....	2-4	Important Waveform Relationships .....	3-7
General .....	2-4	<b>SEQUENTIAL EQUIVALENT-TIME SAMPLING</b> ....	3-10
Before You Begin .....	2-4	Additional Circuits Required .....	3-10
Test Equipment Required .....	2-4	Constructing the Display .....	3-12
Setup Procedure .....	2-5	Waveform Relationships .....	3-12
Adjusting SWEEP CAL .....	2-5	Factors Affecting Dot Density .....	3-15
Observing a Fast Rise Pulse .....	2-6	Blanking .....	3-15
<b>DETAILED OPERATING INFORMATION</b> .....	2-7	Unavoidable Delay Introduced by the 7T11A .....	3-17
Triggering Considerations .....	2-7	<b>RANDOM EQUIVALENT-TIME SAMPLING</b> .....	3-17
Triggering Rate .....	2-7	Introduction .....	3-17
SWEEP RANGE Control .....	2-8	Random Mode Block Diagram .....	3-18
TIME/DIV Settings .....	2-8	Random Operation .....	3-18
TIME POSITION Control .....	2-9	Waveform Relationships During Random	
SCAN Control .....	2-10	Sampling .....	3-20
TRIG LEVEL and STABILITY Controls .....	2-10	<b>DETAILED CIRCUIT DESCRIPTION</b> .....	3-22
Trigger Pushbutton Switches .....	2-11	Introduction .....	3-22
PULSE OUT Connector .....	2-11	Relationships Between the 7T11A and	
Use of Real-Time Mode .....	2-11	Vertical Unit .....	3-22
Use of a 50 $\Omega$ Delay Line .....	2-11	<b>TRIGGER INPUT</b> .....	3-24
Random Sampling .....	2-11	General .....	3-24
		Internal Triggering .....	3-24
		EXT 50 $\Omega$ Triggering .....	3-25
		EXT 1 M $\Omega$ Triggering .....	3-25
		HF Sync .....	3-26
		Trigger Slope Amplifier, SLOPE (-) or (+) .....	3-28
		Trigger Amplifier (TRIG AMP X1, X10) .....	3-28
		<b>TRIGGER &amp; HOLDOFF</b> .....	3-29
		Schmitt Trigger .....	3-29
		Holdoff Multivibrator (HOMV) .....	3-30
		Real-Time HOMV Switching .....	3-31
		Equivalent-Time HOMV Switching .....	3-33
		Arming and Output Tunnel Diodes .....	3-36
		Output TD Circuits .....	3-36
		<b>TIME TO HEIGHT CONVERTER</b> .....	3-37
		Start Multivibrator .....	3-37
		TTH Circuit .....	3-38

## WARNING

The remainder of this Table of Contents lists the servicing instructions. These servicing instructions are for use by qualified personnel only. To avoid electrical shock, do not perform any servicing other than that called out in the Operating Instructions unless qualified to do so.



## TABLE OF CONTENTS (CONT.)

	PAGE		PAGE
SLEWING RAMP & RT MULTIVIBRATOR .....	3-41	Resistor Color Code .....	4-3
Slewing Ramp Generator .....	3-42	Capacitor Marking .....	4-3
Slewing Ramp Comparator and		Diodes .....	4-3
Strobe Drivers .....	3-42	Semiconductor Lead Configuration .....	4-3
Real-Time Multivibrator .....	3-43	Multi-Pin Connector Identification .....	4-3
RATEMETER .....	3-43	Interface Connector Pin Locations .....	4-3
General .....	3-43	TRUBLESHOOTING TECHNIQUES .....	4-6
Pretrigger Comparator .....	3-44	1. Check Control Settings .....	4-6
Triple Log Ramp .....	3-44	2. Check Associated Test Equipment .....	4-6
Reset Multivibrator .....	3-44	3. Visual Check .....	4-6
T <sub>0</sub> Memory and T <sub>0</sub> Gate .....	3-44	4. Check Instrument Adjustment .....	4-6
Start Correction .....	3-45	5. Isolate Trouble to a Circuit .....	4-6
HORIZONTAL AMPLIFIER .....	3-46	6. Check Voltage and Waveforms .....	4-7
Amplifier .....	3-46	7. Check Individual Components .....	4-7
Horizontal Memory Gate Driver .....	3-47	8. Repair and Readjust the Circuit .....	4-7
Horizontal Memory and Gate .....	3-47	TRUBLESHOOTING PROCEDURE .....	4-8
SLOW RAMP GENERATOR & OUTPUT		CORRECTIVE MAINTENANCE .....	4-10
AMPLIFIER .....	3-48	OBTAINING REPLACEMENT PARTS .....	4-10
Slow Ramp Generator - REP SCAN .....	3-48	Standard Parts .....	4-10
Blanking .....	3-49	Special Parts .....	4-10
MAN and EXT INPUT SCAN .....	3-50	Ordering Parts .....	4-10
Dot Position Memory .....	3-51	SOLDERING TECHNIQUES .....	4-10
Output Amplifier .....	3-51	Circuit Boards .....	4-10
SLOW RAMP INVERTER .....	3-52	Metal Terminals .....	4-11
General .....	3-52	COMPONENT REPLACEMENT .....	4-11
Time Position Amplifier .....	3-52	Circuit Board Replacement .....	4-11
Slow Ramp Inverter .....	3-52	Circuit Board Pin Replacement .....	4-12
TIMING SWITCHES .....	3-52	Circuit Board Pin Socket Replacement .....	4-12
General .....	3-53	End-Lead Pin Connector Replacement .....	4-12
Readout .....	3-53	Coaxial End-Lead Connector Replacement .....	4-12
VOLTAGE DISTRIBUTION & DECOUPLING .....	3-54	Multiple End-Lead Connector Replacement .....	4-12
Real-Time and Equivalent-Time Logic .....	3-54	Tunnel Diode A3CR28 Replacement .....	4-13
		Switch Replacement .....	4-13
<b>SECTION 4 - MAINTENANCE</b>		Lamp Replacement .....	4-15
PREVENTIVE MAINTENANCE .....	4-1	ADJUSTMENT AFTER REPAIR .....	4-15
CLEANING .....	4-1	REPACKAGING FOR SHIPMENT .....	4-15
Exterior .....	4-1		
Interior .....	4-1	<b>SECTION 5 - CHECKS AND ADJUSTMENT</b>	
LUBRICATION .....	4-1	PRELIMINARY INFORMATION .....	5-1
VISUAL INSPECTION .....	4-1	Using These Procedures .....	5-1
SEMICONDUCTOR CHECKS .....	4-1	Partial Procedures .....	5-2
PERIODIC ELECTRICAL ADJUSTMENT .....	4-1	Performance Check Summary .....	5-2
TROUBLESHOOTING .....	4-2	Adjustment Interval .....	5-4
TROUBLESHOOTING AIDS .....	4-2	Tektronix Field Service .....	5-4
Diagrams .....	4-2	TEST EQUIPMENT REQUIRED .....	5-4
Circuit Board Illustrations .....	4-2	Special Fixtures .....	5-4
Adjustments and Test Point Locations .....	4-2	Test Equipment Alternatives .....	5-4
Static Sensitive Device Classification .....	4-2		
Wiring Color Code .....	4-3		

## TABLE OF CONTENTS (CONT.)

	PAGE		PAGE
PART I - PERFORMANCE CHECK.....	5-8	A. TRIGGER ADJUSTMENTS.....	5-26
PERFORMANCE CHECK INDEX.....	5-8	B. SCAN AND TIMING.....	5-31
PERFORMANCE CHECK POWER-UP		C. TRIGGER OPERATION.....	5-43
SEQUENCE.....	5-8		
A. SCAN AND TIMING.....	5-9	<b>SECTION 6 - INSTRUMENT OPTIONS</b>	
B. TRIGGERING.....	5-14		
PART II - PERFORMANCE CHECK AND		<b>SECTION 7 - REPLACEABLE ELECTRICAL PARTS LIST</b>	
ADJUSTMENT.....	5-24		
PERFORMANCE CHECK AND ADJUSTMENT		<b>SECTION 8 - DIAGRAMS AND CIRCUIT BOARD ILLUSTRATIONS</b>	
INDEX.....	5-24		
PERFORMANCE CHECK AND ADJUSTMENT		<b>SECTION 9 - REPLACEABLE MECHANICAL PARTS LIST</b>	
POWER-UP SEQUENCE.....	5-25		

## LIST OF ILLUSTRATIONS

FIGURE NO.	PAGE	FIGURE NO.	PAGE
		3-2	7T11A complete block diagram for Real-time sampling. .... 3-3
1-1	Several plug-in configurations using the 7T11A and a 7000-series oscilloscope. .... 1-2	3-3	Circuit waveforms at control settings shown in Figure 3-1. .... 3-4
1-2	Plug-in configurations using the 7T11A and a three-compartment 7000-series oscilloscope. .... 1-3	3-4	Timing relationships during the first 1/50th of one typical Real-time sweep. 7T11A control settings as given in Figure 3-1. .... 3-5
2-1	Connector J641 (fixed shoe), providing inter-connection between 7T11A and 7S11 for strobe and trigger signals. .... 2-1	3-5	TTH ramp voltage versus time at the three Real-time positions of the SWEEP RANGE control. .... 3-7
2-2	Front-panel controls, connectors, and indicators. .... 2-2	3-6	Effect of the TIME POSITION and TIME/POSITION controls. SWEEP RANGE set at 5 ms/div to 10 $\mu$ s/div positions. .... 3-8
2-3	Equipment setup for Operators Checkout Procedure. .... 2-4	3-7	Ideal Trigger, Sweep, and HOMV waveform relationships during real-time sampling. .... 3-9
2-4	Sequential equivalent-time sampling display of 1 $\mu$ s, 1 V square-wave output of pulse generator. ... 2-5	3-8	Simplified sequential equivalent-time block diagram. .... 3-11
2-5	Observing the leading edge of a fast-rise pulse using the SEQUENTIAL equivalent-time mode. .... 2-7	3-9	Ideal waveform relationships during sequential equivalent-time sampling. .... 3-13
2-6	Position of selected TIME/DIV setting within control window and corresponding magnification rate. .... 2-9	3-10	Effect of turning TIME POSITION control fully clockwise on waveforms of Figure 3-9. .... 3-14
2-7	Effect of TIME POSITION control (SWEEP RANGE at 5 $\mu$ s/div to 10 ns/div position). .... 2-10	3-11	7T11A blanking logic. .... 3-16
2-8	Real-time sampling display of the 0.2 V, 1 kHz output of a 7000-series oscilloscope calibrator. ... 2-11	3-12	Unavoidable delay between trigger point on input signal and start of display window. .... 3-17
3-1	Simplified block diagram of a sampling system using the 7T11A as a Real-time sweep unit. .... 3-2	3-13	Effect of lead time in moving display window. .... 3-18
		3-14	Random mode block diagram. .... 3-19
		3-15	Ideal waveform relationships during Random equivalent-time sampling. .... 3-21

## LIST OF ILLUSTRATIONS (CONT.)

FIGURE NO.	PAGE	FIGURE NO.	PAGE
3-16	Display of samples taken in Figure 3-15. . . . .	3-22	
3-17	Block diagram showing interconnections between 7T11A and vertical plug-in during real-time operation. . . . .	3-23	
3-18	Block diagram of the 7T11A trigger circuit. . . . .	3-25	
3-19	Simplified 7T11A Trigger Selector circuit showing use of right channel Sampling Unit as source of internal trigger signal. . . . .	3-26	
3-20	Simplified diagram of HF SYNC circuit. . . . .	3-27	
3-21	Relationship of the output Tunnel Diode to other 7T11A circuits. . . . .	3-28	
3-22	Simplified schematic of the Schmitt Trigger circuit. . . . .	3-30	
3-23	Operating characteristics of Schmitt Trigger circuit tunnel diode (CR134). . . . .	3-31	
3-24	Outputs of the HOMV and associated circuits. . . . .	3-32	
3-25	Trigger, Sweep, and HOMV waveform relationships during real-time sampling. . . . .	3-34	
3-26	Typical waveform relationships during sequential equivalent-time sampling. . . . .	3-35	
3-27	Trigger output circuits. . . . .	3-37	
3-28	Block diagram of circuits shown on TIME TO HEIGHT CONVERTER schematic. . . . .	3-39	
3-29	Active portion of the TTH circuit when producing a negative-going output ramp. . . . .	3-40	
3-30	Equivalent circuit of Miller Integrator used to generate TTH ramp. . . . .	3-41	
3-31	Simplified block diagram of Ratemeter circuit. . . . .	3-42	
3-32	Theoretical change in voltage of Ratemeter Triple Log Ramp capacitor (C414) with charging time. . . . .	3-44	
3-33	Simplified diagram showing sources of Horizontal Amplifier offset current. . . . .	3-45	
3-34	Slow Ramp Generator block diagram. . . . .	3-49	
3-35	Inputs and outputs of the Slow Ramp Inverter. . . . .	3-50	
4-1	Resistor and capacitor color code. . . . .	4-4	
4-2	Semiconductor lead configuration. . . . .	4-5	
4-3	Orientation of multi-pin connectors. . . . .	4-6	
4-4	Pin numbering on interface connector. . . . .	4-6	
4-5	Exploded view of circuit-board pin and ferrule. . . . .	4-12	
4-6	Location of 200 MHz oscillator tunnel diode (A3CR28). . . . .	4-13	
4-7	Minimum range required for the 200 MHz oscillator. . . . .	4-14	
4-8	Connections to switch assemblies. . . . .	4-16	
4-9	Connections to Interface assembly A4. . . . .	4-18	
5-1	Typical displays for checking timing accuracy. . . . .	5-11	
5-2	Sweep Out waveform to check Repetitive Scan rate. . . . .	5-12	
5-3	Determining display jitter. . . . .	5-19	
5-4	Typical display of the Pulse Out waveform. . . . .	5-22	
5-5	Typical display of trigger kickout. . . . .	5-22	
5-6	Positioning Trigger circuit board for access to internal adjustments. . . . .	5-25	
5-7	Typical display of Memory Gate blowby. . . . .	5-33	
5-8	Typical display for adjusting Slewing Ramp (A3R310) and Servo Zero (A1R588). . . . .	5-34	
5-9	Typical display for adjusting Dot Position Memory (A1R645) and Servo Zero (A1R588). . . . .	5-34	
5-10	Typical displays for checking timing accuracy. . . . .	5-38	
5-11	Sweep Out waveform to check Repetitive Scan rate. . . . .	5-39	
5-12	Typical display for HF Sync adjustments. . . . .	5-40	
5-13	Determining display jitter. . . . .	5-47	
5-14	Typical display of the Pulse Out waveform. . . . .	5-51	
5-15	Typical display of trigger kickout. . . . .	5-52	
5-16	Trigger holdoff measurement. . . . .	5-53	
5-17	Typical display of strobe kickback. . . . .	5-53	
8-1	Semiconductor lead configurations.		
8-2	Location of circuit boards in the 7T11A.		
8-3	A3—Trigger circuit board assembly.		
8-4	A2—Timing circuit board assembly.		
8-5	A1—Logic circuit board assembly.		
8-6	A4—Interface circuit board assembly.		
8-7	Location of Logic adjustments.		
8-8	Location of Timing adjustments.		
8-9	Location of Trigger adjustments.		

# LIST OF TABLES

TABLE NO.		PAGE
1-1	Electrical Characteristics .....	1-1
1-2	Mechanical Characteristics .....	1-6
2-1	Minimum Trigger Holdoff .....	2-8
2-2	Sweep Range and Time/Div Settings .....	2-9
3-1	Effect of TIME/DIV Control on Horizontal Amplifier Gain .....	3-XX46
3-2	7T11A Readout Switching .....	3-53
4-1	Relative Susceptibility to Damage from Static Discharge .....	4-2
4-2	Power Supply Wire Color Code .....	4-3
5-1	Performance Check Summary .....	5-3
5-2	Test Equipment .....	5-5
5-3	Timing .....	5-10
5-4	Low-Frequency Triggering .....	5-16
5-5	Medium-Frequency Triggering .....	5-16
5-6	High-Frequency Triggering .....	5-16
5-7	Display Jitter with Optimum Trigger Conditions ...	5-20
5-8	Timing .....	5-37
5-9	Low-Frequency Triggering .....	5-45
5-10	Medium-Frequency Triggering .....	5-45
5-11	High-Frequency Triggering .....	5-45
5-12	Display Jitter with Optimum Trigger Conditions ...	5-49
5-13	Trigger Holdoff .....	5-53

## OPERATORS SAFETY SUMMARY

The following general safety information applies to all operators and service personnel. Specific warnings and cautions will be found throughout the manual where they apply and should be followed in each instance.

**WARNING** statements identify conditions or practices which could result in personal injury or loss of life.

**CAUTION** statements identify conditions or practices which could result in damage to the equipment or other property.

### WARNING

#### GROUND THE INSTRUMENT

*To reduce electrical-shock hazard, the mainframe (oscilloscope) chassis must be properly grounded. Refer to the mainframe manual for grounding information.*

#### DO NOT REMOVE INSTRUMENT COVERS

*To avoid electric-shock hazard, operating personnel must not remove the protective instrument covers. Component replacement and internal adjustments must be made by qualified service personnel only.*

#### DO NOT OPERATE IN EXPLOSIVE ATMOSPHERE

*To avoid explosion, do not operate this instrument in an explosive atmosphere unless it has been certified for such operation.*

### CAUTION

#### PREVENT INSTRUMENT DAMAGE

*To prevent instrument damage, plug-in units should not be installed or removed without first turning off the mainframe power.*

# SERVICE SAFETY SUMMARY

## FOR QUALIFIED SERVICE PERSONNEL ONLY

The following are safety precautions which appear in the service information sections of this manual. This Service Safety Information is in addition to the Operators Safety Information given previously.

### WARNING

#### DO NOT SERVICE ALONE

*Do not attempt internal service or adjustment unless another person, capable of rendering first aid and resuscitation, is present.*

#### DISCONNECT INSTRUMENT POWER

*To avoid electrical-shock hazard, disconnect the instrument from the power source before removing protective panels, soldering, or replacing components.*

### CAUTION

#### AVOID EXCESSIVE MOISTURE

*Circuit boards and components must be dry before applying power to prevent damage from electrical arcing.*

#### EXERCISE CARE WHEN SOLDERING

*The Interface and Timing circuit boards are a multilayer type with conductive paths laminated between the top and bottom board layers. All soldering on these boards should be done with care to prevent breaking connections to the inner conductors. Only experienced maintenance personnel should attempt repair of any circuit board.*

#### USE PROPER CLEANING AGENTS

*Avoid the use of chemical cleaning agents which might damage the plastics used in this instrument. Use a nonresidue type of cleaner, preferably isopropyl alcohol, totally denatured ethyl alcohol, or a fluorinated solvent (i.e., trifluorotrchloroethane), such as Freon TF cleaner or Spray-On #2002. Before using any other type of cleaner, consult your Tektronix Service Center or representative.*

#### DO NOT USE PIN SOCKETS FOR CONNECTION POINTS

*The spring tension of the pin sockets ensures a good connection between the circuit board and the pin. This spring tension can be destroyed by using the pin sockets as a connecting point for spring-loaded probe tips, alligator clips, etc.*

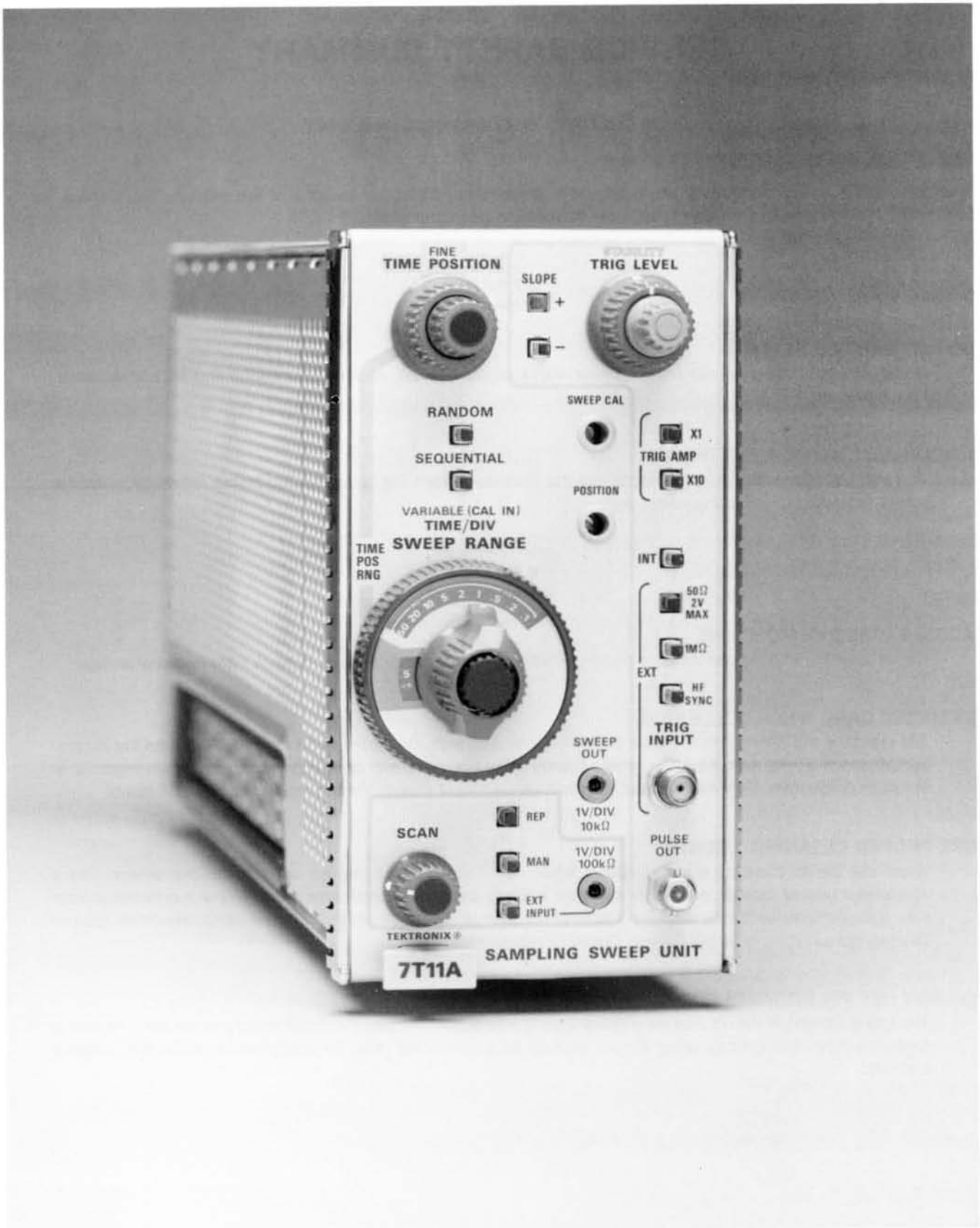

7T11A Sampling Sweep Unit.

# SECTION 1 SPECIFICATION

## General Information

The 7T11A Sampling unit is designed for use in Tektronix 7000-series oscilloscopes. Several plug-in combinations, including a 7T11A, are shown in Fig. 1-1. A 7S11 must be in the compartment to the left of, and adjacent to, the compartment in which the 7T11A is operated. Therefore, two 7T11A's are not used in the same mainframe.

In Fig. 1-1A the 7T11A is shown in the "A" Horizontal compartment of the oscilloscope. The Vertical Mode and Horizontal Mode pushbuttons, providing useful presentations, are designated for plug-in configurations A, B and C. For the configuration of Fig. 1-1A, four combinations are shown. An alternate to the configuration shown in Fig. 1-2B is with the "LEFT" or "B" or both of these mainframe compartments empty. Plug-in arrangements other than those shown in Fig. 1-1 are possible.

Fig. 1-2 shows several plug-in combinations for three compartment oscilloscopes. In these configurations, the 7T11A must be in the Horizontal plug-in compartment and a 7S11 must be in the Right Vertical compartment. Vertical mode pushbuttons adding useful presentations are designated for each configuration.

The 7M11 may be used in any available mainframe compartment or operated out of the mainframe. For further information, see the Operating Instructions section of this manual under the heading of Detailed Operating Information.

## Instrument Features

The 7T11A features a wide range of sweep rates using real-time and equivalent-time sampling. Concentric switches select the sweep range and time position range in different combinations for the time/div desired. On equivalent time ranges, either sequential or random sampling is available. Use of random sampling permits display of the leading edge of fast-rise input signals without the use of a signal delay line (such as the 7M11) or a pretrigger pulse from the signal source.

Internal triggering, or any of three modes of external triggering can be selected by using the front panel pushbuttons. A Schmitt trigger circuit is used except when HF SYNC is selected. With EXT 50  $\Omega$  input selected, the Schmitt circuit provides jitter free triggering from input trigger signals from DC to 1 GHz. The display is free of trigger jitter or double triggering, even at low trigger repetition rates or when using a square wave as the input trigger signal. A recovery time control is not needed.

Selecting EXT HF SYNC permits using frequencies of 1 GHz to approximately 12 GHz as the trigger input source. With HF SYNC selected, the signal connected to the TRIG INPUT connector is routed to a built-in synchronizer, thus permitting X band signals to be viewed.

Excellent sweep linearity is provided when using the 7T11A. The timing circuitry in the 7T11A uses a time measurement rather than a time programming process for horizontal sample positioning on all equivalent-time sweep ranges. During both Random and Sequential operation the horizontal position of the dot on the screen is determined by measuring the time interval between strobe and trigger. This method results in improved timing linearity and a reduction in display jitter. The accuracy of sweep timing and linearity make it unnecessary, during equivalent time sampling, to exclude the sweep start from accuracy specifications.

## Characteristics

The following characteristics apply over an ambient temperature range of 0°C to +50°C at altitudes up to 15,000 feet and after a five-minute warmup, providing the instrument was calibrated at a temperature between +20°C and +30°C. During non-operation, do not subject the 7T11A to altitudes above 50,000 feet or to temperatures below -55°C.



Plug-In Configuration	Mainframe Switching																																																						
	VERTICAL MODE	HORIZONTAL MODE																																																					
<table border="1"> <thead> <tr> <th>Left</th> <th>Right</th> <th>"A"</th> <th>"B"</th> </tr> </thead> <tbody> <tr> <td>7S11</td> <td>7S11</td> <td>7T11</td> <td>7M11</td> </tr> </tbody> </table> <p>(A)</p>	Left	Right	"A"	"B"	7S11	7S11	7T11	7M11	<table border="1"> <thead> <tr> <th>LEFT</th> <th>ALT</th> <th>ADD</th> <th>CHOP</th> <th>RIGHT</th> </tr> </thead> <tbody> <tr> <td>X</td> <td></td> <td></td> <td></td> <td></td> </tr> <tr> <td></td> <td></td> <td>X</td> <td></td> <td></td> </tr> <tr> <td></td> <td></td> <td></td> <td>X</td> <td></td> </tr> <tr> <td></td> <td></td> <td></td> <td></td> <td>X</td> </tr> </tbody> </table>	LEFT	ALT	ADD	CHOP	RIGHT	X							X						X						X	<table border="1"> <thead> <tr> <th>A</th> <th>ALT</th> <th>CHOP</th> <th>B</th> </tr> </thead> <tbody> <tr> <td>X</td> <td></td> <td></td> <td></td> </tr> <tr> <td>X</td> <td></td> <td></td> <td></td> </tr> <tr> <td>X</td> <td></td> <td></td> <td></td> </tr> <tr> <td>X</td> <td></td> <td></td> <td></td> </tr> </tbody> </table>	A	ALT	CHOP	B	X				X				X				X			
Left	Right	"A"	"B"																																																				
7S11	7S11	7T11	7M11																																																				
LEFT	ALT	ADD	CHOP	RIGHT																																																			
X																																																							
		X																																																					
			X																																																				
				X																																																			
A	ALT	CHOP	B																																																				
X																																																							
X																																																							
X																																																							
X																																																							
<table border="1"> <tbody> <tr> <td>7A--</td> <td>7S11</td> <td>7T11</td> <td>7B--</td> </tr> </tbody> </table> <p>(B)</p>	7A--	7S11	7T11	7B--	<table border="1"> <tbody> <tr> <td>X</td> <td></td> <td></td> <td></td> <td></td> </tr> <tr> <td></td> <td></td> <td></td> <td></td> <td>X</td> </tr> <tr> <td></td> <td>X</td> <td></td> <td></td> <td></td> </tr> </tbody> </table>	X									X		X				<table border="1"> <tbody> <tr> <td></td> <td></td> <td></td> <td>X</td> </tr> <tr> <td>X</td> <td></td> <td></td> <td></td> </tr> <tr> <td></td> <td></td> <td>X</td> <td></td> </tr> </tbody> </table>				X	X						X																							
7A--	7S11	7T11	7B--																																																				
X																																																							
				X																																																			
	X																																																						
			X																																																				
X																																																							
		X																																																					
<table border="1"> <tbody> <tr> <td></td> <td>7S11</td> <td>7S11</td> <td>7T11</td> </tr> <tr> <td>blank</td> <td></td> <td></td> <td></td> </tr> </tbody> </table> <p>(C)</p>		7S11	7S11	7T11	blank				<table border="1"> <tbody> <tr> <td></td> <td></td> <td></td> <td></td> <td>X</td> </tr> <tr> <td></td> <td></td> <td></td> <td></td> <td>X</td> </tr> <tr> <td></td> <td></td> <td></td> <td></td> <td>X</td> </tr> </tbody> </table>					X					X					X	<table border="1"> <tbody> <tr> <td>X</td> <td></td> <td></td> <td></td> </tr> <tr> <td></td> <td></td> <td></td> <td>X</td> </tr> <tr> <td></td> <td></td> <td>X</td> <td></td> </tr> </tbody> </table>	X							X			X																			
	7S11	7S11	7T11																																																				
blank																																																							
				X																																																			
				X																																																			
				X																																																			
X																																																							
			X																																																				
		X																																																					

6176-1

Figure 1-1. Several plug-in configurations using the 7T11A and a 7000-series oscilloscope.

**TABLE 1-1  
ELECTRICAL CHARACTERISTICS**

Characteristic	Performance Requirement
<b>SWEEP RATES</b>	
TIME/DIV	Calibrated from 5 ms/div to 10 ps/div, selectable in a 1, 2, 5 sequence, using SWEEP RANGE and TIME/DIV controls.
Equivalent Time	5 $\mu$ s/div to 10 ps/div using the 50 $\mu$ s to 50 ns Time Position Ranges.
Accuracy	Within 3%.
Real Time	5 ms/div to .1 $\mu$ s/div using the 50 ms to .5 ms Time Position Ranges.
Accuracy On 50 ms TIME POS RNG	Within 3%, beginning 250 $\mu$ s after undelayed sweep start.
On 5 ms TIME POS RNG	Within 3%, beginning 25 $\mu$ s after undelayed sweep start.
On 0.5 ms TIME POS RNG	Within 3%, beginning 2.5 $\mu$ s after undelayed sweep start, or after 500 ns from start of displayed portion of sweep. Does not include 100 ns/div and 200 ns/div positions.
VARIABLE (TIME/DIV) Range	Extends fastest sweep rate to at least 4 ps/div. Permits increasing the speed of all sweep rates to at least 2.5 times the calibrated speed.

Plug-in Configuration	Mainframe Vertical Modes																
<p>(A)</p> <table border="1" style="margin-left: auto; margin-right: auto;"> <thead> <tr> <th>Left</th> <th>Right</th> <th>Horiz</th> </tr> </thead> <tbody> <tr> <td>7S11</td> <td>7S11</td> <td>7T11A</td> </tr> </tbody> </table>	Left	Right	Horiz	7S11	7S11	7T11A	<table border="1" style="margin-left: auto; margin-right: auto;"> <thead> <tr> <th>LEFT</th> <th>ALT</th> <th>ADD</th> <th>CHOP</th> <th>RIGHT</th> </tr> </thead> <tbody> <tr> <td>X</td> <td></td> <td>X</td> <td>X</td> <td>X</td> </tr> </tbody> </table>	LEFT	ALT	ADD	CHOP	RIGHT	X		X	X	X
Left	Right	Horiz															
7S11	7S11	7T11A															
LEFT	ALT	ADD	CHOP	RIGHT													
X		X	X	X													
<p>(B)</p> <table border="1" style="margin-left: auto; margin-right: auto;"> <thead> <tr> <th>Left</th> <th>Right</th> <th>Horiz</th> </tr> </thead> <tbody> <tr> <td>7---</td> <td>7S11</td> <td>7T11A</td> </tr> </tbody> </table>	Left	Right	Horiz	7---	7S11	7T11A	<table border="1" style="margin-left: auto; margin-right: auto;"> <thead> <tr> <th>LEFT</th> <th>ALT</th> <th>ADD</th> <th>CHOP</th> <th>RIGHT</th> </tr> </thead> <tbody> <tr> <td></td> <td></td> <td></td> <td></td> <td>X</td> </tr> </tbody> </table>	LEFT	ALT	ADD	CHOP	RIGHT					X
Left	Right	Horiz															
7---	7S11	7T11A															
LEFT	ALT	ADD	CHOP	RIGHT													
				X													

6176-2

Figure 1-2. Plug-in configurations using the 7T11A and a three-compartment 7000—series oscilloscope.

**TABLE 1-1 (cont)  
ELECTRICAL CHARACTERISTICS**

Characteristic	Performance Requirement
<b>TRIGGERING</b>	
Input Resistance EXT 50 $\Omega$	50 $\Omega$ within 10%.
EXT 1 M $\Omega$	1 M $\Omega$ within 5%.
EXT HF SYNC	1 M $\Omega$ within 5%.
*Sinewave Triggering Internal	
Sensitivity Range X1 Trig Amp	125 mV to 1 V P-P at vertical input (5 kHz to 500 MHz).
X10 Trig Amp	12.5 mV to 1 V P-P at vertical input (5 kHz to 50 MHz).
	*NOTE Trigger circuits will operate to DC with pulse triggering, except for HF SYNC.
External	
50 $\Omega$ Input Sensitivity Range X1 Trig Amp	12.5 mV to 2 V (P-P), DC to 1 GHz.
X10 Trig Amp	1.25 mV to 2 V (P-P), 1 kHz to 50 MHz.
Safe Overload	2 V (DC + peak AC).
1 M $\Omega$ Input Sensitivity Range X1 Trig Amp	12.5 mV to 2 V (P-P), DC to 100 MHz.
X10 Trig Amp	1.25 mV to 2 V (P-P), 1 kHz to 50 MHz.
Safe Overload	100 V DC or 100 V (P-P) to 1 kHz; derated 6 dB/octave above 1 kHz to 5 V (P-P).
HF SYNC Input Sensitivity Range	10 mV to 500 mV (peak-peak) at 1 GHz; 200 mV to 500 mV (peak-peak) at 12.4 GHz.
Safe Overload	2 V (peak-peak).
Display Jitter 50 $\Omega$ and 1 M $\Omega$ Triggering Sequential Mode	10 ps or less at fastest SWEEP RANGE position (fully CCW); 0.4 divisions or less at remaining six positions of SWEEP RANGE; measurements made under optimum trigger conditions.

**TABLE 1-1 (cont)**  
**ELECTRICAL CHARACTERISTICS**

Characteristic	Performance Requirement
<b>TRIGGERING (cont)</b>	
Random Mode	30 ps or less at fastest SWEEP RANGE position (fully CCW); one division or less at remaining six positions of SWEEP RANGE; measurements made under optimum trigger conditions.
HF SYNC Random or Sequential Mode	20 ps or less with a 12.4 GHz, 200 mV (peak-peak) signal; measured under optimum trigger conditions.
PULSE OUT (into 50 $\Omega$ ) Amplitude	Positive-going pulse of at least 400 mV.
Risetime	2.5 ns or less.
Trigger Kickout	$\pm 2$ mV or less into 50 $\Omega$ (except HF SYNC).
Minimum Trigger Rate in RANDOM Mode	100 Hz.

**SLOW RAMP GENERATOR**

Scan Rate REPETITIVE SCAN	Continuously variable from less than 2 sweeps/sec to at least 40 sweeps/sec.
------------------------------	--

**HORIZONTAL DEFLECTION SYSTEM**

Deflection Factor SWEEP CAL	Permits adjustment of deflection factor for all 7000-series mainframes.
EXTERNAL INPUT Input Resistance	100 k $\Omega$ within 10%.
Deflection Factor	Continuously variable from 10 V to 1 V/div.
Maximum Input Voltage	100 V (DC + peak AC).
SWEEP OUT	1 V/div within 2%.
Output Resistance	10 k $\Omega$ within 1%.

**TABLE 1-2**  
**MECHANICAL CHARACTERISTICS**

Characteristic	Performance Requirement
Dimensions Height	≈ 5 inches.
Width	≈ 2 3/4 inches.
Length (including front panel knobs and rear connector)	≈ 15 inches.
Construction	Aluminum alloy chassis with epoxy laminated circuit boards. Front panel is anodized aluminum.
Accessories	An illustrated list of the accessories supplied with the 7T11A is at the end of the Mechanical Parts List pullout pages.

## SECTION 2 OPERATING INSTRUCTIONS

### General Information

This section covers installation, first time operation, function of front panel controls and connectors, and general operation of the 7T11A Sampling Sweep Unit.

The 7T11A is intended for use in the Tektronix 7000-series oscilloscopes. Use of the 7T11A with a 7S11 Sampling Unit and any of a variety of S-series Sampling Heads provides a sampling system adaptable to a wide range of applications.

Real-time sampling is provided at the three slowest sweep rate settings of the 7T11A Sweep Range switch. Sampling is in equivalent-time for the remaining four positions of the Sweep Range switch. On these four ranges either sequential or random equivalent-time sampling may be selected.

The 7T11A sweep may be synchronized using an internal or external triggering source. External signals from DC up to approximately 12 GHz can be used as the trigger source. A trigger amplifier providing X10 amplification is available.

#### NOTE

*Internal trigger signals are not routed through the trigger source switches on the oscilloscope due to the frequencies involved and noise considerations. Selection of the trigger source is made on the front panel of the plug-ins.*

Triggering signals travel between plug-in units along 50  $\Omega$  coaxial or strip lines. These signals travel between plug-in units using contacts on connector strips fastened to the sides of the plug-ins. A connector strip is shown in Fig. 2-1. Since the strobe pulses also travel between a 7T11A and 7S11 plug-in through contacts on the connector strips, these units must be located in adjacent oscilloscope compartments.

### Installing the 7T11A in the Oscilloscope

The 7T11A is designed to drive the horizontal deflection plates of the oscilloscope CRT, and therefore is installed in the right-hand compartment of a three-compartment oscilloscope. When only one 7T11A and one 7S11 are used in a 7000-series oscilloscope providing two vertical and two horizontal compartments, the 7T11A is inserted in the left-hand

horizontal compartment and the 7S11 in the right-hand vertical compartment. This provides an interconnecting path between the 7T11A and the 7S11 for strobe and trigger signals.

To insert the 7T11A into the oscilloscope compartment, align the grooves along the top and bottom of the plug-in with the upper and lower slide rails in the oscilloscope compartment. The unit slides straight in and self-locks itself in place. The plug-in is removed by pulling straight out on the plastic button labeled 7T11A.

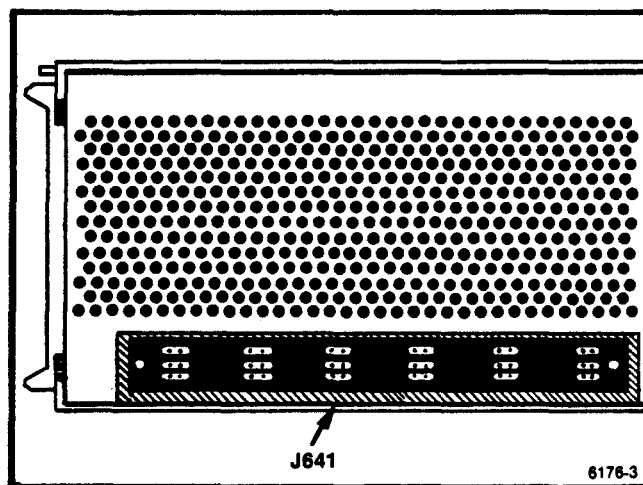
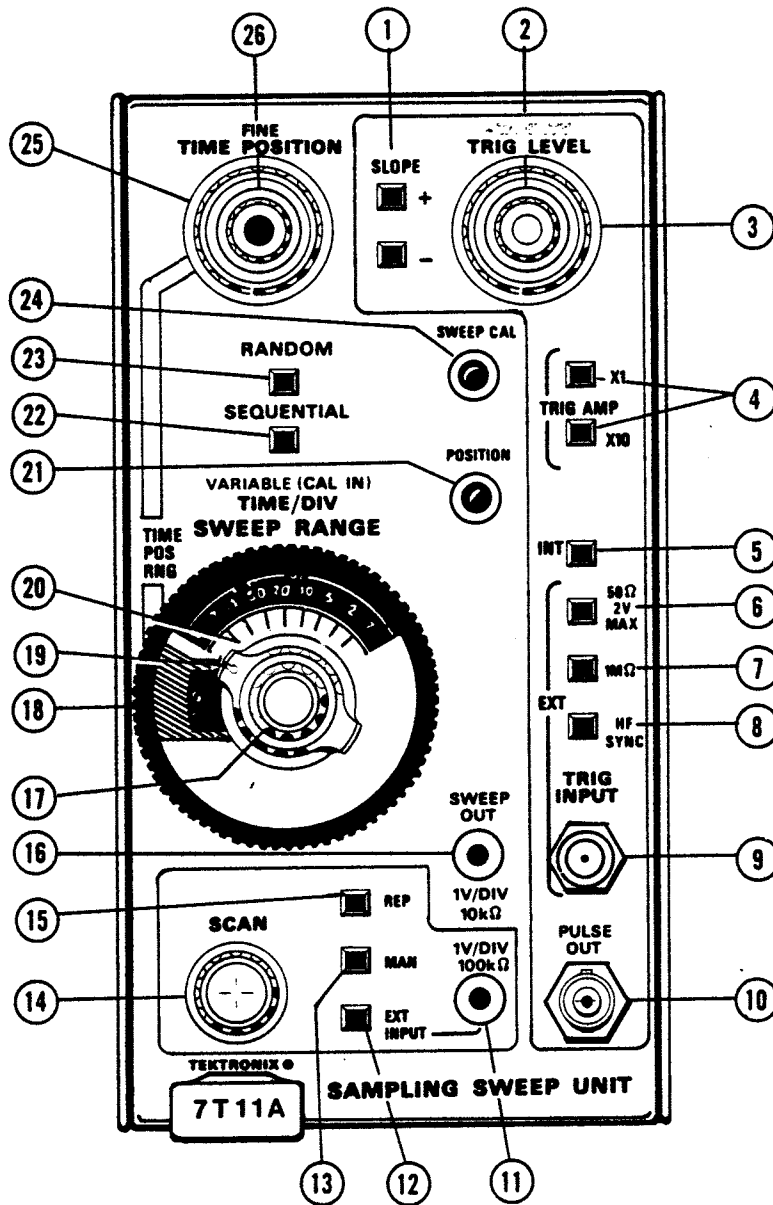

Figure 2-1. Connector J641 (fixed shoe), providing interconnection between 7T11A and 7S11 for strobe and trigger signals.

### 7T11A Horizontal Gain

The 7T11A horizontal gain must be matched to the horizontal deflection factor of the CRT in the oscilloscope. Horizontal gain is set using the Sweep Cal control (screwdriver adjustment) located on the 7T11A front panel. A method of adjusting the Sweep Cal is discussed in the Operators Checkout Procedure later in this section. This adjustment must be reset each time the 7T11A is transferred between oscilloscopes, and when a considerable change in ambient temperature occurs.



6176-4

Figure 2-2. Front-panel controls, connectors and indicators.

## TRIGGERING

- 1 SLOPE (+), (-) Pushbuttons—Selects the positive-going (+) or negative-going (-) slope of the triggering signal.
- 2 STABILITY Control—Adjusts the width of the trigger hysteresis. Also serves as a coarse sync adjustment in the HF SYNC mode.
- 3 TRIG LEVEL Control—Determines the amplitude level on the triggering waveform where triggering is to occur. Also serves as a fine synchronizing adjustment in the HF SYNC mode. The TRIG LEVEL control is concentric with the STABILITY control.
- 4 TRIG AMP Pushbuttons—Selects X1 or X10 amplification of the trigger signal.
- 5 INT Pushbutton—Selects internal triggering for operation with sampling heads that provide a trigger pickoff.
- 6 EXT 50  $\Omega$  Pushbutton—Selects external, DC-coupled, low-impedance trigger operation at the common trigger input connector.
- 7 EXT 1 M $\Omega$  Pushbutton—Selects external, DC-coupled, high-impedance trigger operation at the common trigger input connector.
- 8 EXT HF SYNC Pushbutton—Selects external, AC-coupled (1 M $\Omega$  to ground) HF SYNC operation. In this mode of trigger operation, the STABILITY and TRIG LEVEL controls are used to obtain a stable display with trigger signals above approximately 1 GHz.
- 9 EXT TRIG INPUT Connector—A 3 mm connector located near the lower right portion of the front panel and used for introducing an external triggering signal to the 7T11A.
- 10 PULSE OUT Connector—A BSM connector providing a positive pulse corresponding to the firing of the trigger circuit.

## SCAN

- 11 External Input Jack—A pin jack (input resistance of 100 k $\Omega$ ) providing an input facility for externally scanning the display. With the SCAN control fully CW a one volt input is needed for each division of display.
- 12 EXT INPUT Pushbutton—Allows scanning the display using an external signal. In this mode of operation, the variable SCAN control serves as a variable attenuator.
- 13 MAN Pushbutton—Provides manual operation of the scan function using the variable SCAN control. Does not function in the three slowest (real-time) Sweep Ranges.
- 14 Variable SCAN Control—Provides an internal voltage for adjusting the scan rate in the REP mode, or for manually scanning the display in the MAN mode. Also used to set the horizontal gain using the SWEEP CAL control. Serves as a variable attenuator in the EXTERNAL INPUT mode.
- 15 REP Pushbutton—Provides repetitive scanning of the display. Scan rate is adjusted using the variable SCAN control. It does not function in the three slowest (real-time) Sweep Ranges.

## SWEEP

- 16 SWEEP OUT Jack—Pin jack providing an output voltage proportional to the display. With an output resistance of 10 k $\Omega$ , an output of one volt for each division of display is provided.
- 17 VARIABLE (CAL IN) Control—When in the out position, rotating the VARIABLE control permits changing time per division from the calibrated value selected by the TIME/DIV switch. Push knob in and release to activate; the knob moves outward from the TIME/DIV control when activated.
- 18 SWEEP RANGE Switch—Selects the range of operation of the TIME/DIV switch and indicates the corresponding time position range (TIME POS RNG). Permits a choice of any of nine TIME/DIV settings at each of the seven positions of the SWEEP RANGE SWITCH. The SWEEP RANGE control is concentric with the TIME/DIV and VAR (CAL IN) controls.
- 19 TIME/DIV Switch—Selects calibrated time/division settings from 10 ps/div to 5 ms/div, in 27 steps, in a 1, 2, 5 sequence.
- 20 TIME POS RNG—Time-positioning ranges from 50 ns to 50 ms in seven decades are available. Time-positioning range available and indicated in the TIME POS RNG window is determined by the setting of the SWEEP RANGE switch. The indicated range is always ten times the slowest time/div of the Sweep Range selected.
- 21 POSITION Control—A front panel screwdriver adjustment to position the display horizontally on the CRT of the oscilloscope.
- 22 SEQUENTIAL Pushbutton—Selects Sequential Sampling mode of operation. Does not function in the three slowest (real-time) Sweep Ranges. Permits equivalent-time operation at lower trigger repetition rates than does the Random mode.
- 23 RANDOM Pushbutton—Selects Random Sampling mode of operation. Does not function in the three slowest (real-time) Sweep Ranges. Permits the display of the input signal prior to the triggering point without use of a delay line or pretrigger.
- 24 SWEEP CAL Control—A front panel screwdriver adjustment that adjusts horizontal gain to match the oscilloscope deflection factor. Adjusted when switching 7T11A from one oscilloscope to another.
- 25 TIME POSITION Control—Permits continuously variable adjustment of delay in starting the display, up to the amount indicated in the TIME POS RNG window.
- 26 FINE Control—Has only about 1% of the effect of the TIME POSITION control, and is particularly useful at TIME/DIV settings of high magnification.

Figure 2-2. (cont). Front-panel controls, connectors and indicators.



### TIME/DIV Readout

The 7T11A TIME/DIV setting selected is displayed near the top of the CRT except when the 7T11A is used in a oscilloscope without readout circuitry. The horizontal position of the readout on the CRT corresponds to the horizontal position of the oscilloscope compartment in use.

The TIME/DIV selected at the 7T11A front panel is displayed on the CRT using the digits 1, 2, or 5 followed by one or two zeros if required. The TIME/DIV readout does not use decimal points. The displayed digits are followed by the units-of-measure readout. With the 7T11A, the units-of-measure displayed will be ms/div,  $\mu$ s/div, ns/div or ps/div. If the VARIABLE (CAL IN) switch is in the out position, the symbol used to indicate less than (<), is displayed preceding the TIME/DIV readout as a warning that the display is uncalibrated. The intensity of the readout is independently adjustable by a front panel control on the oscilloscope, which also permits the readout to be switched off.

## FRONT PANEL CONTROLS AND CONNECTORS

All controls required for operation of the 7T11A are located on the front panel of the unit (see Fig. 2-2). Controls, pushbuttons, and connectors associated with triggering are located along the right side of the front panel and are included in an area outlined in green. The SCAN control, pushbuttons, and an external input connector are in a grey outlined area at the lower left of the panel. The remainder of the front panel contains Sweep circuit controls, switches, and adjustments.

A brief description of the function or operation of the front panel controls is provided in Figure 2-2. More detailed information is given under the heading of Detailed Operating Information.

## OPERATORS CHECKOUT PROCEDURE

### General

When shipped from the factory, the 7T11A Sampling Sweep Unit has been calibrated to meet the specifications listed in Section 1 and is ready to be used with a Tektronix 7000-series oscilloscope.

The following procedures are intended to demonstrate basic instrument function. It is recommended that this procedure be followed completely for familiarization with the instrument. Operation of the oscilloscope and vertical plug-in unit (Sampling Unit) is described in the instruction manuals for these units. The equipment set-up used during the following procedure is shown in Fig. 2-3.

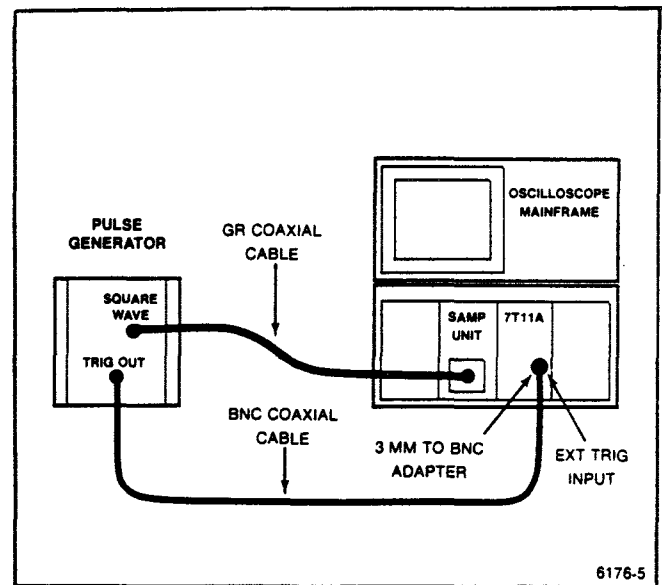

Figure 2-3. Equipment setup for Operators Checkout Procedure.

### Before You Begin:

Refer to the Change Information at the rear of this manual for any modifications which may affect this procedure.

### Test Equipment Required

The following test equipment was used in preparing the Operators Checkout Procedure. Other test equipment which meets the same requirements may be substituted. When other equipment is substituted, the control settings or setup information may need to be altered.

1. 7S11 Sampling Unit.
2. Sampling Head (e.g., S-1 or S-2).
3. 7000-series oscilloscope (e.g., 7704A, 7904A, or 7603).
4. Pulse generator (e.g., TEKTRONIX Type 284).
5. 50-ohm delay line, 75 ns (Optional, for use when pretrigger is not available; e.g., TEKTRONIX 7M11).
6. 50-ohm coaxial cable: 5 ns delay, GR874 connectors, Tektronix Part No. 017-0512-00 (two may be required if a delay line is used).

**Setup Procedure**

1. Insert a 7S11 Sampling Unit with a Sampling Head installed in the right vertical compartment of the oscilloscope.

2. Insert a 7T11A Sampling Sweep Unit in the "A" horizontal plug-in compartment.

3. Set the front-panel controls as follows:

**7S11**

+UP pushbutton ..... Pushed in  
 DC Offset control ..... Midposition  
 mVolt/Div switch ..... 200  
 Normal pushbutton ..... Pushed in

**7T11A**

TIME POSITION controls ..... Fully clockwise  
 SEQUENTIAL pushbutton ..... Pushed in  
 TIME POS RNG ..... 5  $\mu$ s  
 TIME/DIV ..... .5  $\mu$ s/Div (500 ns readout)  
 VARIABLE (CAL IN) control ..... Pushed in  
 SCAN control ..... Midposition  
 REP pushbutton ..... Pushed in  
 STABILITY control ..... Fully CCW  
 TRIG LEVEL control ..... Midposition  
 SLOPE pushbutton ..... (+) pushed in  
 TRIG AMP pushbutton ..... X10 pushed in  
 EXT 50  $\Omega$  triggering pushbutton ..... Pushed in

**Pulse Generator**

Square Wave Amplitude ..... 1.0 V  
 Period ..... 1  $\mu$ s  
 Mode ..... Square Wave  
 Trigger Lead Time ..... 75 ns

4. Turn on power and let the equipment warm up for approximately 20 minutes.

5. Set the mainframe vertical and horizontal modes to display the plug-ins used. See the oscilloscope instruction manual for detailed operating instructions.

6. Connect a 50  $\Omega$  coaxial cable having a 5 ns signal delay and GR874 connectors between the pulse generator output connector and the input connector of the Sampling Head.

7. Connect the Trigger Output connector of the pulse generator to the 7T11A TRIG INPUT connector through a 50  $\Omega$  coaxial cable with a 2 ns signal delay and BNC connectors. A 3 mm male to BNC adapter (Tektronix Part No. 015-1018-00), included as a standard accessory with the 7T11A, must be connected to the 3 mm TRIG INPUT connector on the 7T11A.

8. Adjust the mainframe Focus and Intensity, and the 7T11A DC Offset controls for a display similar to that shown in Fig. 2-4. Rotate the SCAN control slowly from one extreme to the other and note that clockwise rotation increases the scan rate and reduces the dot density. Return the SCAN control to its midposition. Push in and release the VARIABLE (CAL IN) control and note that the less than symbol (<) is displayed on the CRT just to the left of the 500 ns readout. Rotate the VARIABLE control from its fully CCW position and note that clockwise rotation results in an increasing magnification of the display or a reduction in actual time per division. Return the VARIABLE control to its fully CCW position and push it into the CAL position.

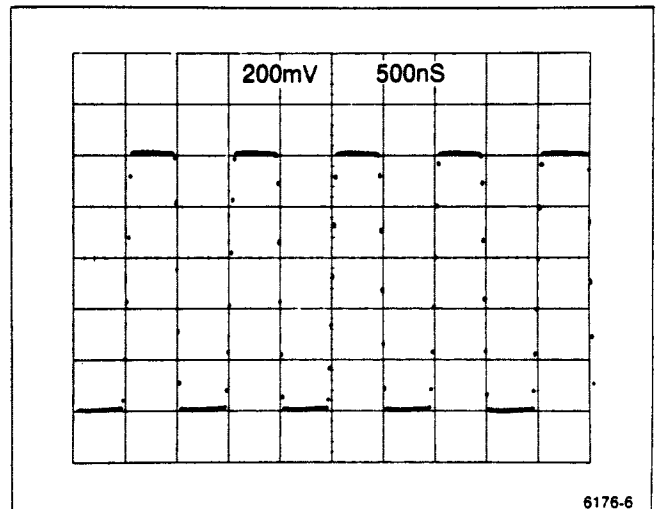

Figure 2-4. Sequential equivalent-time sampling display of 1  $\mu$ s, 1 V square-wave output of pulse generator.

**Adjusting SWEEP CAL**

1. Push the MAN SCAN pushbutton in and observe that the pushbutton lights. Turn the SCAN control fully counter-clockwise. A spot should be observed at the left edge of the graticule. Rotate the SCAN control to its fully CW position. The spot should have moved exactly ten divisions to the right of its previous position. Use a small screwdriver to adjust the SWEEP CAL on the 7T11A front panel for ten divisions of movement when the SCAN control is turned from one extreme to the other. This adjustment should be

## Operating Instructions—7T11A

made whenever the plug-in is switched to a different oscilloscope. This adjustment should be checked occasionally even if the plug-in remains with the same oscilloscope.

2. The POSITION control on the 7T11A front panel is adjusted with a screwdriver so the spot appears at the left graticule edge with the SCAN control fully CCW. Return the SCAN to repetitive by pushing the REP pushbutton and set the SCAN control to its approximate midposition.

### Observing a Fast-Rise Pulse

One method of observing the leading edge of a fast-rise pulse is to use a slow enough sweep so that the pulse following the one producing triggering is displayed. Either Internal or External triggering can be used. By using the TIME POSITION control to move the displayed pulse near to the left graticule edge and turning the TIME/DIV switch clockwise to a setting providing high magnification, satisfactory results can be obtained if the input signal has the proper characteristics. The input signal repetition rate must be constant; otherwise jitter or a meaningless display will result. Also, if the interval between pulses is excessively long compared to the time interval of interest, a suitable combination of TIME POS RNG and TIME/DIV will be unattainable.

Two other methods of seeing before the triggering point, without the limitations of the method above, are available during Sequential equivalent-time sampling. These methods provide a means of getting the trace started before the vertical signal reaches the CRT vertical deflection plates.

The first of these methods is to lengthen the path that the vertical signal must travel from the signal source to the Sampling Head, while the distance traveled by the triggering signal is kept as short as possible. This method, using a 50  $\Omega$  delay line, is discussed later in this section under the heading of Detailed Operating Information.

The method used for the Operators Checkout procedure is to use a signal source that provides a signal for triggering slightly before it delivers an output pulse to the Sampling Head input. A pretrigger lead time of 75 ns is required.

1. Change the settings on the following controls:

#### Pulse Generator

Mode . . . . . Pulse Output

#### 7S11

mV/Div . . . . . 50 mV/Div

#### 7T11A

TIME POS RNG . . . . . 50 ns  
TIME/DIV . . . . . 5 ns

2. Connect the coaxial cable between the pulse generator Pulse Output and the Sampling Head. Check that the readout displayed on the CRT is 5 ns, and vertically center the display using the 7S11 DC Offset control.

3. With the TIME POSITION controls fully CW, the leading edge of the output pulse of the pulse generator should be visible as shown in the typical display of Fig. 2-5A. Fig. 2-5A shows that although the generator is supplying a trigger 75 ns before the Pulse Output signal, the signal is displayed only 7 or 8 ns after the trace starts. If the 3 ns difference in travel time through the coaxial cables delivering the vertical input and trigger input signals is considered, the actual effective trigger lead time is approximately 78 ns. In Fig. 2-5A the lead time is only 7 or 8 ns more than the minimum required to display the input signal leading edge. The location of the pulse in Fig. 2-5A is typical. Factors that will affect the horizontal position, of the pulse leading edge with respect to the start of the sweep are: differences in the pretrigger lead time provided by different pulse generators, differences in the delay within different 7T11A's, and the setting of the TRIG LEVEL control.

4. Rotate the TIME POSITION and FINE controls slowly CCW and notice that they increase delay and thereby cause the displayed pulse to move to the left. Using the TIME POSITION controls, set the pulse leading edge one division from the left edge of the graticule as shown in Fig. 2-5B. Disconnect the coaxial cable from the input of the Sampling Head and insert an additional 5 ns length of coaxial cable between the cable just disconnected and the Sampling Head input. The additional 5 ns of delay inserted in the path of the input signal will cause the pulse to move one division (5 ns) to the right as shown in Fig. 2-5C. This provides a means of providing additional lead time and also a means of determining the delay caused by a length of cable.

5. Turn the TIME/DIV switch to the .2 ns/Div position (200 ps readout on CRT) and use the TIME POSITION control to horizontally position the pulse leading edge to graticule center. Note that the FINE control has more effect in moving the display as the TIME/DIV control is set to its more clockwise positions.

#### NOTE

*Consult the instruction manual for the Sampling Head being used to determine the fastest risetime which may be accurately measured.*

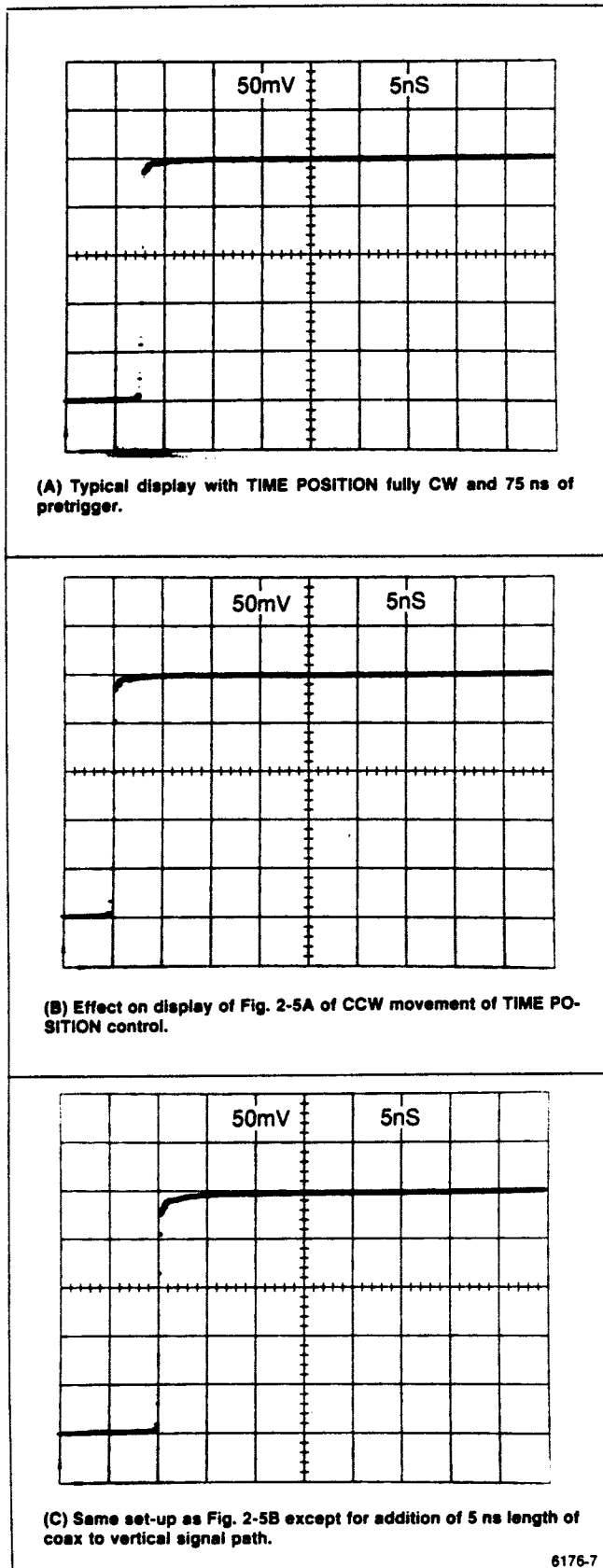

Figure 2-5. Observing the leading edge of a fast-rise pulse using the SEQUENTIAL equivalent-time mode.

6. Turn the oscilloscope Intensity control fully counter-clockwise and push in the HF SYNC pushbutton. The HF SYNC pushbutton will light and the X10 TRIG AMP and + SLOPE lights will go out. When using HF SYNC, the triggering slope and the TRIG AMP controls have no effect.

7. Rotate the SWEEP RANGE control fully CW to where the TIME POS RNG window shows 50 ms. Real-time sampling is provided at this setting of the SWEEP RANGE control as well as at the next two faster SWEEP RANGE settings. The SEQ or RANDOM pushbuttons will not light on these three real-time ranges. The SCAN controls are also inoperative on real-time ranges and these pushbuttons will not light.

## DETAILED OPERATING INFORMATION

### Triggering Considerations

When using Sequential equivalent-time sampling to observe a fast risetime pulse, a pretrigger or external delay line is normally required. Use of a 50  $\Omega$  delay line is discussed later in this section.

Internal triggering or any one of three modes of External triggering can be selected by using four pushbuttons on the 7T11A front panel. Triggering signals are not routed through the pushbuttons. The front panel pushbuttons control need relays located in the 50  $\Omega$  path provided for triggering signals. (Triggering controls on the oscilloscope mainframe have no controlling effect). This triggering system reduces pickup of unwanted noise and loss of high frequency components of the trigger signals.

Internal triggering of the 7T11A from the signal applied to either vertical channel is available. Pushing in the INT pushbutton on the 7T11A will cause this button to light. The INT pushbutton lights on the 7S11 that is supplying the triggering signal.

### Triggering Rate

Triggering rate is limited by holdoff. The minimum trigger holdoff time at each of the seven available time positioning ranges (indicated in the TIME POS RNG window) is shown in Table 2-1. The TIME POS RNG is determined by the setting of the SWEEP RANGE control.

**TABLE 2-1**  
**Minimum Trigger Holdoff**

	Indication in TIME POS RNG window	Minimum Trigger Holdoff Time
<b>Real Time</b>	50 ms	at least 2 ms
	5 ms	at least 2 ms
	500 $\mu$ s	at least 2 ms
<b>Equiv. Time</b>	50 $\mu$ s	at least 220 $\mu$ s
	5 $\mu$ s	at least 25 $\mu$ s
	500 ns	at least 25 $\mu$ s
	50 ns	at least 25 $\mu$ s

The maximum rate at which triggers can be recognized is the reciprocal of the minimum trigger holdoff time shown in Table 2-1. In real-time operation, delay introduced using the TIME POSITION controls and the duration of the time window (ten times the TIME/DIV setting) must be added to the minimum values shown in Table 2-1. The Sweep Range providing the greatest time-positioning range and the slowest real-time sweep can therefore cause the greatest variation from the minimum holdoff time shown in Table 2-1.

In Random mode the triggering point,  $T_0$  is displayed close to the center line of the CRT with the Time Position control fully CW and the Time/Div switch fully CCW. The lowest allowable triggering rate for the 7T11A in Random mode is 100 Hz; this applies to all equivalent-time Sweep Ranges. The lowest usable triggering rate for any particular Time/Div setting depends on the minimum dot density that the operator is willing to use. In Random mode, the sampling event referenced to a particular trigger is timed from the preceding trigger. If the trigger rate is high and uniform, then the sampling event prediction is more accurate and the samples occur where they are programmed to occur. As the rate goes down, the ability to predict when the next trigger will occur diminishes, and the samples begin to happen in a more random fashion. When the trigger rate slows (or the period jitter increases) sufficiently, the predictability is reduced to the point where the sampling distribution falls over the whole screen. In this case, best dot density is obtained by selecting MAN SCAN and placing the center of the dot distribution at mid-screen.

### **SWEEP RANGE Control**

Sweep rate of the display is controlled by three concentric knobs. The outer, larger knob (SWEEP RANGE control) controls the sweep range over which the TIME/DIV knob may be switched. The window on the left of the TIME/DIV knob displays the TIME POS RNG (time positioning range);

this number is always 10 times the slowest available TIME/DIV of a particular SWEEP RANGE setting. The selected TIME/DIV is displayed on the CRT by the oscilloscope if the oscilloscope is provided with readout capability. The VARIABLE control can provide a minimum of 2.5 to 1 magnification at any TIME/DIV setting. At the three slowest SWEEP RANGE settings, sampling is in real-time while the remaining four positions provide equivalent-time (random or sequential) sampling.

The TIME/DIV settings available at each position of the SWEEP RANGE control are shown in Table 2-2. Turning the SWEEP RANGE control fully CW selects the slowest setting of the SWEEP RANGE control. Thus the fully CW position has been designated as SWEEP RANGE position 1 in Table 2-2. Reading horizontally to the right from the fully CW (designated as position 1 in Table 2-2) SWEEP RANGE position shows, under the TIME POS RNG column, a value of 50 ms. Continuing to the right shows that nine TIME/DIV settings, from 5 ms/div at X1 magnification to 10  $\mu$ s/div at X500 magnification, are available. As the SWEEP RANGE control is rotated CCW increasingly faster Sweep Ranges are selected.

It should be noted that the nine TIME/DIV settings available at each of the seven positions of the SWEEP RANGE control provide a total of 63 combinations. Only 27 different TIME/DIV settings are available, however, since most TIME/DIV settings are available at two or three settings of the SWEEP RANGE control. For example, TIME/DIV settings of 50  $\mu$ s, 20  $\mu$ s and 10  $\mu$ s are shown in Table 2-2 to be available at all three real-time positions of the SWEEP RANGE control. If a TIME/DIV setting of 20  $\mu$ s/div is required, any of the three real-time Sweep Ranges can be used; however, more time-positioning range (TIME POS RNG) is provided at the slower SWEEP RANGE settings.

### **TIME/DIV Settings**

A total of 27 different sweep rates are available ranging from 5 ms/div to 10 ps/div in a 5, 2, 1 sequence (see Table 2-2). On the slowest SWEEP RANGE position a total of nine TIME/DIV settings (5 ms/div to 10  $\mu$ s/div) are available. Each of the six other positions of the SWEEP RANGE also offer a choice of nine TIME/DIV settings.

The nine TIME/DIV control settings determine the amount of display magnification. See Fig. 2-6. On all Sweep Ranges the display magnification changes from X1 to X500 in a 1, 2.5, 5 sequence as the selected TIME/DIV setting is changed from the slowest available rate to the fastest.

**TABLE 2-2**  
**SWEEP RANGE and TIME/DIV Settings**

	Sweep Range Position	TIME POS RNG	TIME/DIV and Magnification								
			CCW	←							CW
			X1	X2.5	X5	X10	X25	X50	X100	X250	X500
Real Time	Fully CW 1	50 ms	5 ms	2 ms	1 ms	.5 ms	.2 ms	.1 ms	50 $\mu$ s	20 $\mu$ s	10 $\mu$ s
	2	5 ms	.5 ms	.2 ms	.1 ms	50 $\mu$ s	20 $\mu$ s	10 $\mu$ s	5 $\mu$ s	2 $\mu$ s	1 $\mu$ s
	3	.5 ms	50 $\mu$ s	20 $\mu$ s	10 $\mu$ s	5 $\mu$ s	2 $\mu$ s	1 $\mu$ s	.5 $\mu$ s	.2 $\mu$ s	.1 $\mu$ s
Equiv. Time	4	50 $\mu$ s	5 $\mu$ s	2 $\mu$ s	1 $\mu$ s	.5 $\mu$ s	.2 $\mu$ s	.1 $\mu$ s	50 ns	20 ns	10 ns
	5	5 $\mu$ s	.5 $\mu$ s	.2 $\mu$ s	.1 $\mu$ s	50 ns	20 ns	10 ns	5 ns	2 ns	1 ns
	6	.5 $\mu$ s	50 ns	20 ns	10 ns	5 ns	2 ns	1 ns	.5 ns	.2 ns	.1 ns
	Fully CCW 7	50 ns	5 ns	2 ns	1 ns	.5 ns	.2 ns	.1 ns	50 ps	20 ps	10 ps

**TIME POSITION Control**

The TIME POSITION control permits delaying the display or time window start by an amount up to the value indicated in the TIME POS RNG window. Delay introduced by this control is removed by turning the control fully clockwise. The FINE control serves the same purpose but has only about 1% as much effect as the TIME POSITION control.

Fig. 2-7A and 2-7B show that the duration of the display or time window is ten times the selected TIME/DIV setting. At the SWEEP RANGE setting specified in Fig. 2-7 the TIME POS RNG (time positioning range) is 50  $\mu$ s. During SEQUENTIAL operation and with the TIME POSITION control fully CW (clockwise) the start of the display or time window occurs just after trigger recognition (time  $T_0$ ).

During RANDOM equivalent-time sampling a lead-time of approximately 1/2 TPR (time-positioning range) is provided. Trigger recognition ( $T_0$ ) will therefore occur at about 25  $\mu$ s with the SWEEP RANGE setting represented in Fig. 2-7. During Random sampling the 50  $\mu$ s of time-positioning range shown in Fig. 2-7B permits seeing from 25  $\mu$ s before  $T_0$  to 35  $\mu$ s after  $T_0$ .

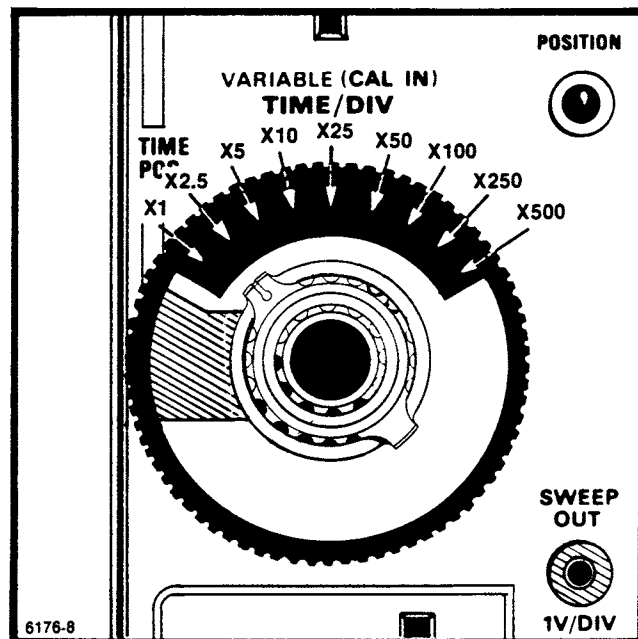

**Figure 2-6.** Position of selected TIME/DIV setting within control window and corresponding magnification rate.

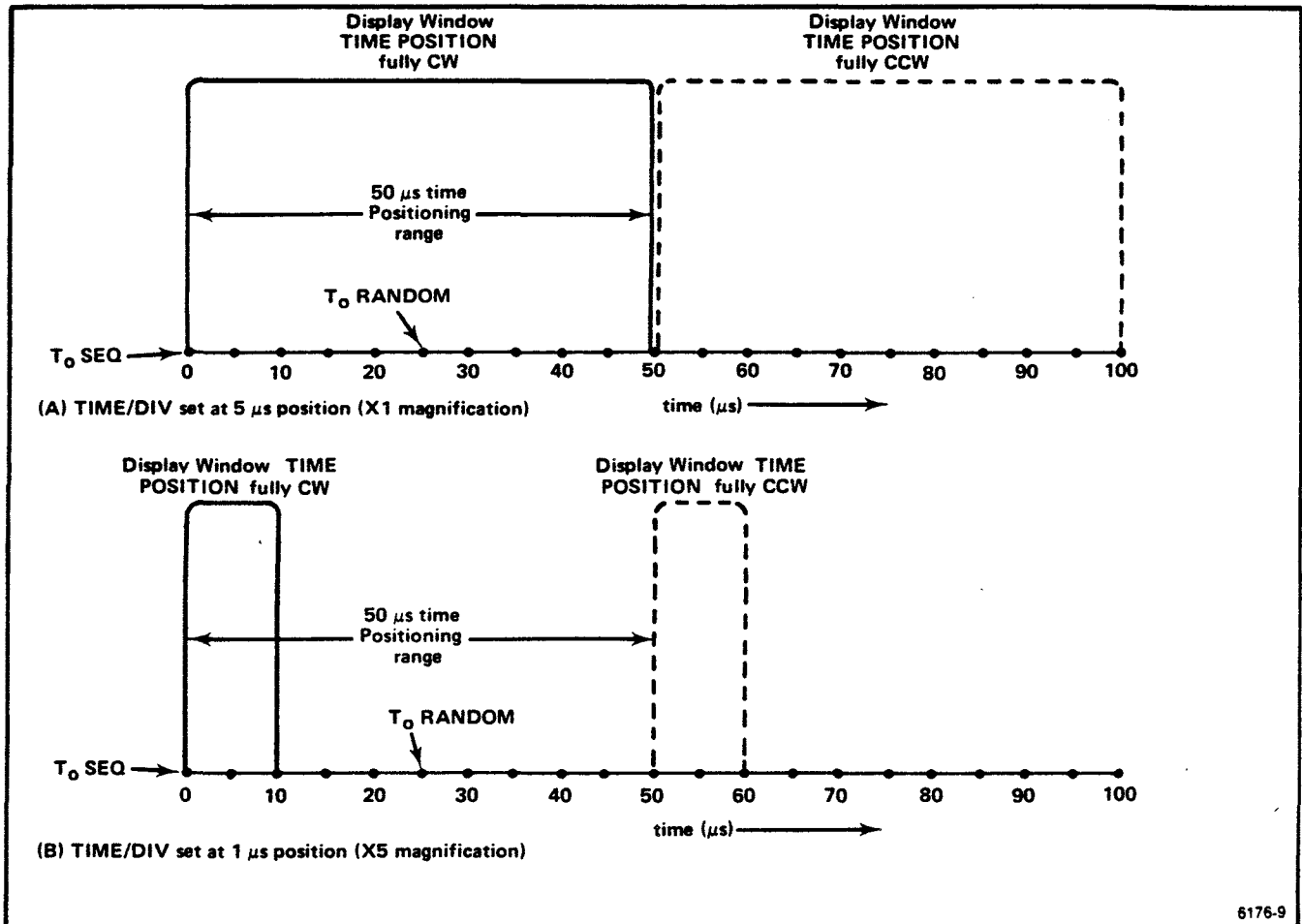

Figure 2-7. Effect of TIME POSITION control (SWEEP RANGE at 5  $\mu\text{s}/\text{div}$  to 10 ns/div position).

The TIME POSITION control also works during real-time operation. The smaller the delay from  $T_0$  the brighter the display.

### SCAN Control

During real-time operation the SCAN control and push-buttons are inoperative and the pushbutton lights go out.

The SCAN control serves three functions, selected by the pushbuttons. Pushing in the REP pushbutton results in a free-running sweep, the scan rate increasing with CW rotation of the SCAN control. Selecting MAN gives a single point of time on the screen, or centers the distribution of samples around a point on the screen. This control also provides a means of setting the SWEEP CAL adjustment for 10 centimeters of scan using a built-in zener diode as a voltage reference. EXT input allows the 7T11A to be driven from other sweep sources, with the SCAN control acting as an attenuator. Single Sweep operation has not been provided, but is possible by EXT INPUT drive from a real-time sweep plug-in.

As mentioned above, turning the SCAN control clockwise increases the scan rate. At faster scan rates the horizontal spacing between dots is increased. Fewer samples per scan are taken, resulting in a decrease in dot density. Counterclockwise rotation of the SCAN control has the opposite effect; scan rate decreases and dot density is increased.

### TRIG LEVEL and STABILITY Controls

These controls provide control of the Schmitt trigger circuit as in a conventional oscilloscope. Rotation clockwise from a central position picks up triggering on a more and more positive portion of the wave; counterclockwise from midrange picks up triggering from more and more negative portions of the triggering signal. The stability control setting is not critical for most triggering situations. A CCW rotation sets the Schmitt hysteresis at about 50 mV when driven by an unamplified waveform. Rotation to CW causes the Schmitt hysteresis bands to overlap, providing free-run operation for trigger level settings near the center of the range. This allows synchronization to signals from 50 MHz to around 1 GHz.

### Trigger Pushbutton Switches

The SLOPE pushbuttons permit selection of triggering on either the (+) or (-) slope of the triggering signal.

A trigger amplifier is provided and pushing in the X10 pushbutton provides amplification of the input trigger signal. This amplifier is switched out when the X1 pushbutton is pushed in. When the unit is switched to HF SYNC, the SLOPE and TRIG AMP switch lights go out because the circuits they control become inoperative.

The remaining four trigger pushbuttons allow the user to select Internal triggering or 3 modes of External triggering, 50  $\Omega$ , 1 megohm, or HF Sync: the most often used for high speed pulse work is the 50  $\Omega$  mode. Both the 50  $\Omega$  and 1 M $\Omega$  positions are DC coupled. In HF SYNC, the signal is routed through a high pass filter to a 200 MHz oscillator, allowing synchronism up to X band signals. The STABILITY control is here used as a coarse sync control; the TRIG LEVEL control is used for fine sync adjustments.

### PULSE OUT Connector

This connector provides a positive-going, 0.5 volt pulse into 50  $\Omega$  that is useful for triggering external circuits for closed loop testing. This pulse occurs shortly after the Trigger recognition point (time  $T_0$ ).

### Use of Real-Time Mode

In general, real-time sampling is used to observe low frequency signals while equivalent-time sampling is used to observe the higher frequency signals. Since the faster real-time TIME/DIV settings are also available using equivalent-time sampling, at these TIME/DIV settings, the mode providing the best display is used.

The real-time sampling display of 0.2 V, 1 kHz square-wave output of a 7000-series oscilloscope calibrator is shown in Fig. 2-8. Few, if any, dots representing samples taken, are visible during the relatively fast rise and fall time of this square wave. During real-time operation the dot density, or samples per division of display, is affected by the TIME/DIV setting. Faster TIME/DIV settings result in a fewer number of samples per division of display.

### Use of a 50 $\Omega$ Delay Line

As mentioned during the Operators Checkout procedure, a 50  $\Omega$  delay line may be used instead of a pretrigger to get the sweep started before the vertical signal reaches the CRT. Consult the instruction manual for the delay line for detailed operating instructions.

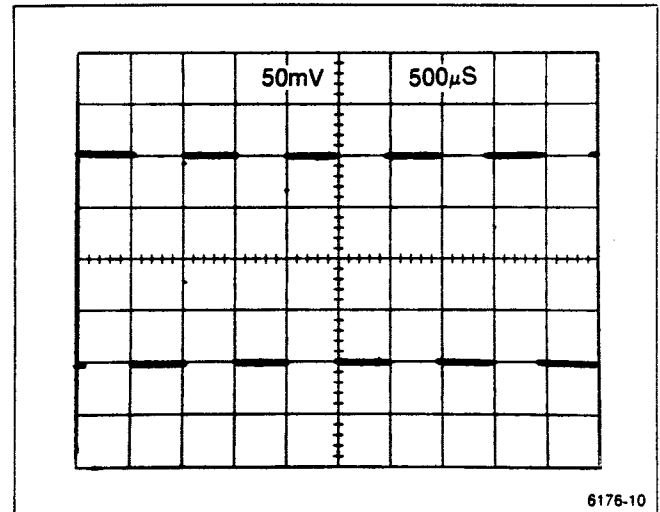

Figure 2-8. Real-time sampling display of the 0.2 V, 1 kHz output of a 7000-series oscilloscope calibrator.

1. Connect the Trigger Output of the delay line through a 50  $\Omega$  coaxial cable to the TRIG INPUT connector on the 7T11A. The 50  $\Omega$  delay line is connected between the signal source and the Sampling Head input.
2. Connect the signal to be observed to the Input connector of the delay line.
3. Connect the output of the delay line to the input of the Sampling Head.

### NOTE

*The effect of the delay line on the input signal must be considered. Consult the delay line instruction manual for details.*

### Random Sampling

Use of the Random mode of sampling provides a sweep that starts before the triggering point on the signal, without the need for a pretrigger or delay line. The loss of input signal amplitude and increase in system risetime resulting from use of the delay line is eliminated in the Random mode. The minimum triggering rate, however, is about 100 Hz during Random operation instead of the 10 Hz rate permissible during Sequential operation. Either Internal or External triggering may be used.



## SECTION 3 THEORY OF OPERATION

### Introduction

This section is divided into two parts: Circuit Theory, and Detailed Circuit Description. The Circuit Theory portion describes the purpose and relationship of the various 7T11A circuits. The three sampling modes are discussed in the following order: Real Time, Sequential Equivalent-Time, and Random Equivalent-Time. The effect of the 7T11A operating controls on each of the three modes is also explained.

The Detailed Circuit Description portion of this section provides a detailed discussion of the 7T11A circuits shown on schematic diagrams in Section 8 of this manual. The purpose of the circuits and of many circuit components shown on these schematics is explained in the Detailed Circuit Description.

Section 2, Operating Instructions, provides information about 7T11A controls which must be understood before beginning this section. For more information on Tektronix Sampling Techniques, read the section entitled "Basic Sampling Principles" in your Sampling Unit instruction manual.

## CIRCUIT THEORY REAL-TIME SAMPLING

### General

In Figure 3-1, the Trigger, TTH Converter, and Horizontal Amplifier serve the same purpose as the Trigger, Sweep Generator, and Horizontal Amplifier circuits in a conventional horizontal sweep unit. The function of these blocks will be discussed first.

The 7T11A Trigger circuit permits triggering at any desired portion of an input signal. A suitable trigger from an internal or external source results in an output from the trigger circuit if the trigger circuit is in a ready-to-fire condition. The time at which the trigger circuit delivers an output is referred to as trigger recognition and is designated as  $T_0$  in this manual. Once the trigger circuit fires, starting the TTH ramp, no further incoming triggers will be recognized until the sweep ends and the recovery time has elapsed.

A selected portion of the negative-going output of the TTH ramp is amplified in the Horizontal Amplifier by an amount dependent upon the selected TIME/DIV setting. The output of the Horizontal Amplifier is fed to the Horizontal Memory circuit. The Horizontal Memory circuit provides X2 amplification of the Horizontal Amplifier output. The output ramp of the Horizontal Memory differs from the usual horizontal deflection signal in that it runs down in a series of voltage steps.

The output of the Horizontal Amplifier is connected to the input of the Horizontal Memory only when the Memory Gate is open. The Memory Gate is controlled by the Real-Time Multivibrator, which is controlled by the Real-Time Oscillator in the vertical plug-in unit.

A ramp amplitude of 10 volts is required at the output of the Horizontal Memory to produce 10 divisions of horizontal deflection on the CRT. The 10-volt ramp at the Horizontal Memory output is fed to the Output Amplifier. The Output Amplifier prevents loading of the Horizontal Memory circuit and changes the single-ended output of the Horizontal Memory to the push-pull horizontal drive signal required by 7000 series-oscilloscopes. The 10-volt output of the Output Amplifier is delivered to a Horizontal Interface board in the oscilloscope, and then to the CRT horizontal deflection plates. If either output of the Output Amplifier exceeds +5 volts the Overrun blanking circuit (now shown in Figure 3-2) is enabled, preventing display of the overrun portion of the sweep.

The 10-volt change at the Horizontal Memory output must occur in 5 ms in order for timing to be correct at the TIME/DIV setting shown in Figure 3-1. Figure 3-3 shows that the TTH Converter output voltage changes only 5 volts in 5 ms at the selected position of the SWEEP RANGE control. With the SWEEP RANGE and TIME/DIV settings given in Figure 3-1, the Horizontal Amplifier has a gain of 1. The fixed X2 gain of the Horizontal Memory provides the required rate of change of voltage. Since the TTH ramp continues to run negative after 5 ms from ramp start as shown in Figure 3-3, the Horizontal Amplifier output continues to run positive. This positive run is stopped by a reset circuit (not shown on Figure 3-1) when the Horizontal Amplifier Output voltage reaches approximately 5.2 volts.

Figure 3-3 shows that the rate of change of the ramp output of the Horizontal Memory is twice that of the ramp output of the Horizontal Amplifier. In addition to providing X2 gain, the Horizontal Memory inverts the applied signal and shifts its starting level from 0 volts to +5 volts. The output from the memory is not the perfect linear ramp it appears to be in Figure 3-3D. The voltage change from +5 volts to -5 volts is accomplished in 250 steps of 40 millivolts each.

### Staircase Ramp Output of the Horizontal Memory

Although the TTH Converter produces a linear ramp, just as the time base generator in a conventional oscilloscope, the ramp leaving the memory (see Figure 3-4D) is a staircase. This is due to the sampling, at regular intervals, of the Horizontal Amplifier output by the Horizontal Memory. The output of the Horizontal Amplifier is connected to the input of the Horizontal Memory only when a memory pulse is applied.

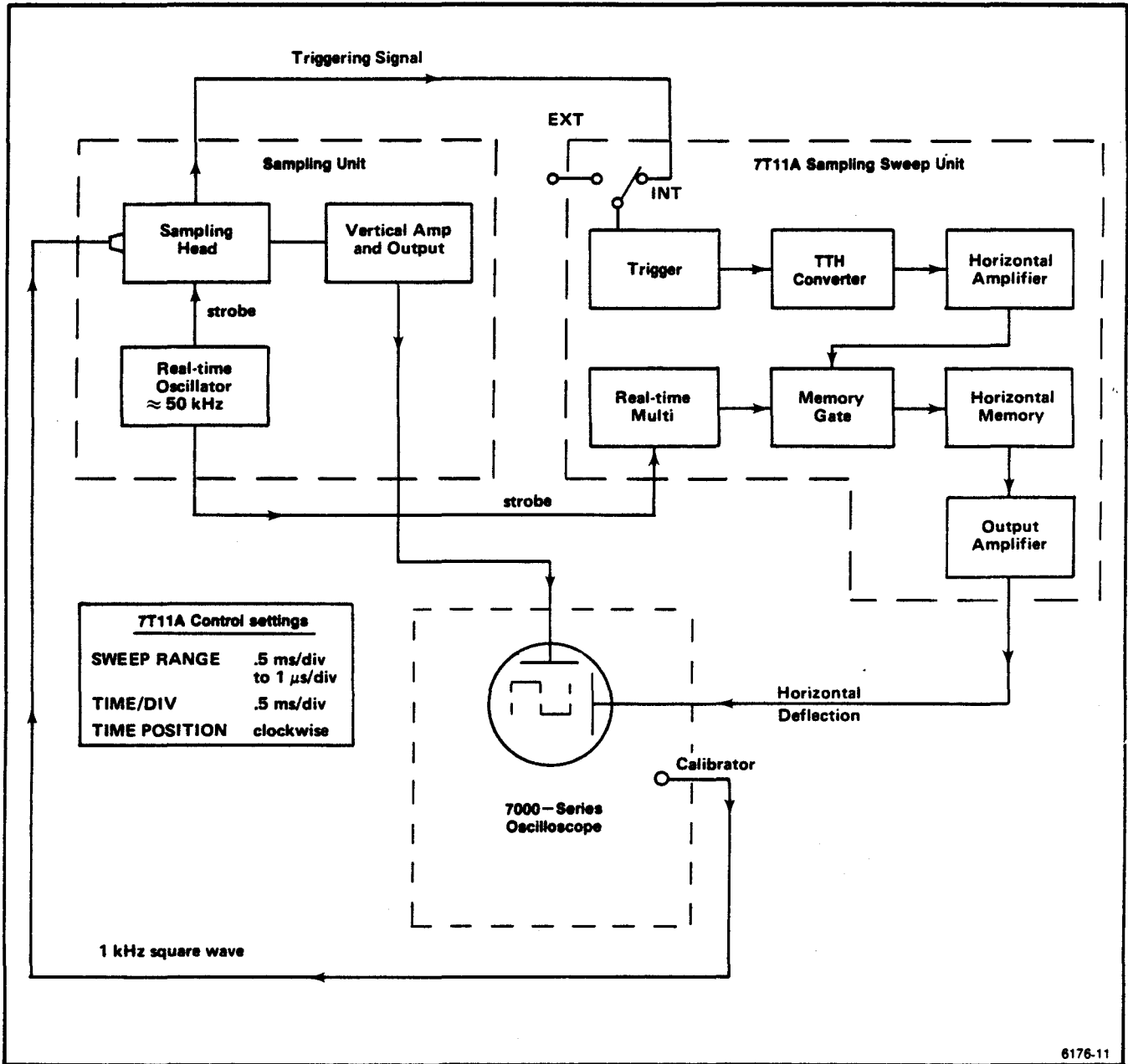

Figure 3-1. Simplified block diagram of a sampling system using the 7T11A as a Real-time Sweep Unit.

plied to the Memory Gate. The action of the Memory Gate changes the linear ramp at the Horizontal Amplifier output to the staircase ramp appearing at the output of the memory. A  $3\ \mu\text{s}$  duration gating pulse is applied from the Real Time Multivibrator to the Memory Gate at intervals of  $20\ \mu\text{s}$ . The  $50\ \text{kHz}$  Real Time Oscillator, shown in Figure 3-1, controls the period of the Real Time Multivibrator and therefore determines the  $20\ \mu\text{s}$  interval between gating pulses. The CRT is blanked during the  $3\ \mu\text{s}$  gating pulse.

### Lead Time During Real-Time Sampling

The Real-Time Oscillator, located in the vertical plug-in unit, and the Real-Time Multivibrator operate only on the

three Real-Time sweep ranges. The Real-Time Oscillator furnishes a strobe pulse to the sampling heads in the vertical plug-ins. The strobe pulse causes the sampling heads to sample the vertical input signal. The amplitude of the input signal is measured at this instant (when the sampling head is strobed) and the signal value is stored in the vertical memory until the next sample is taken  $20\ \mu\text{s}$  later. Samples are not displayed until  $3\ \mu\text{s}$  after they are taken because the CRT is blanked during the  $3\ \mu\text{s}$  memory gating pulse. Since the voltage applied to the horizontal deflection plates is changing during this  $3\ \mu\text{s}$  blanking interval, all samples are displayed approximately  $3\ \mu\text{s}$  to the right of where they might be expected to occur. This effectively gives the 7T11A lead time during real-time sampling and results in the triggering point being displayed approximately  $3\ \mu\text{s}$  after sweep start.

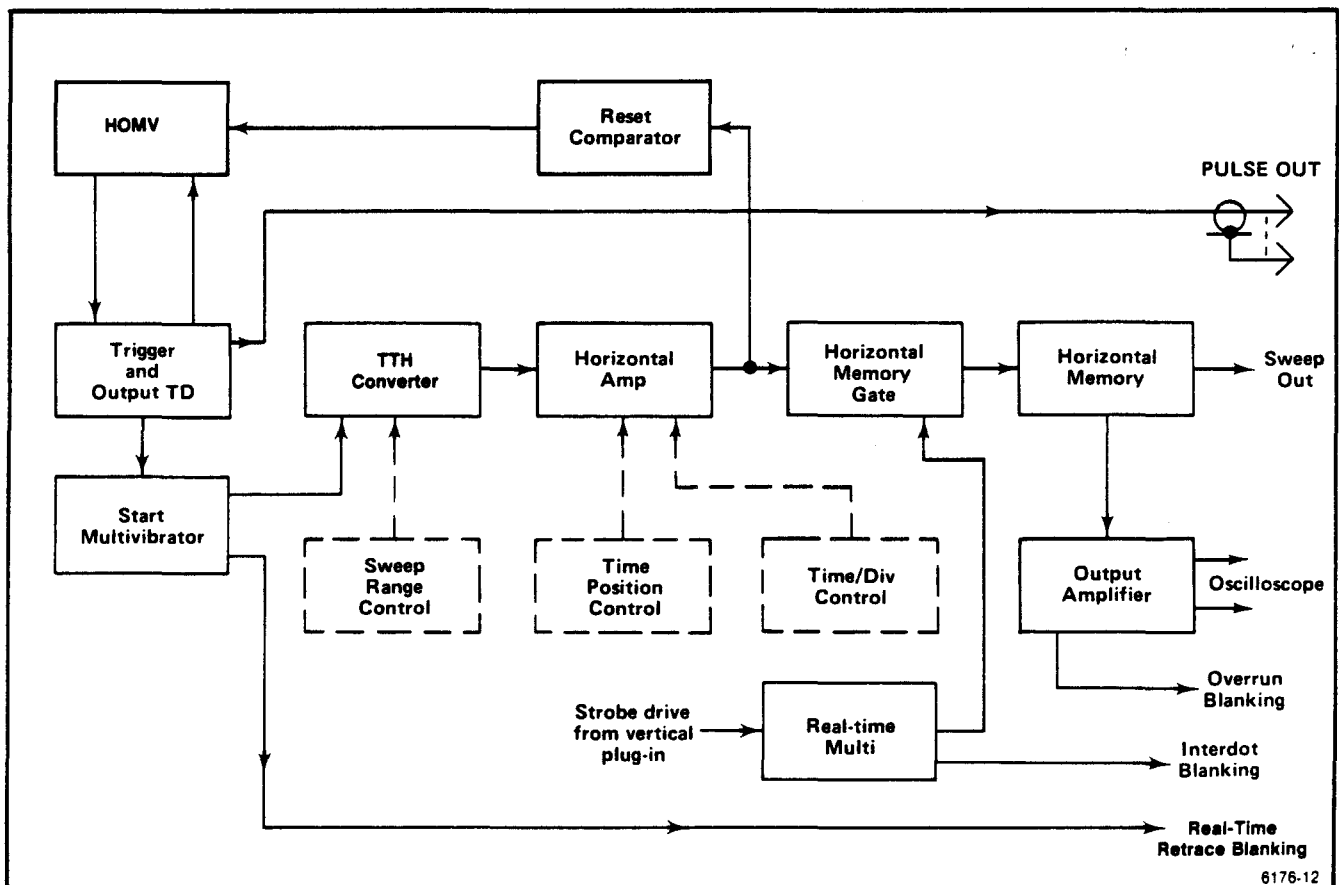

Figure 3-2. 7T11A complete block diagram for Real-time sampling.

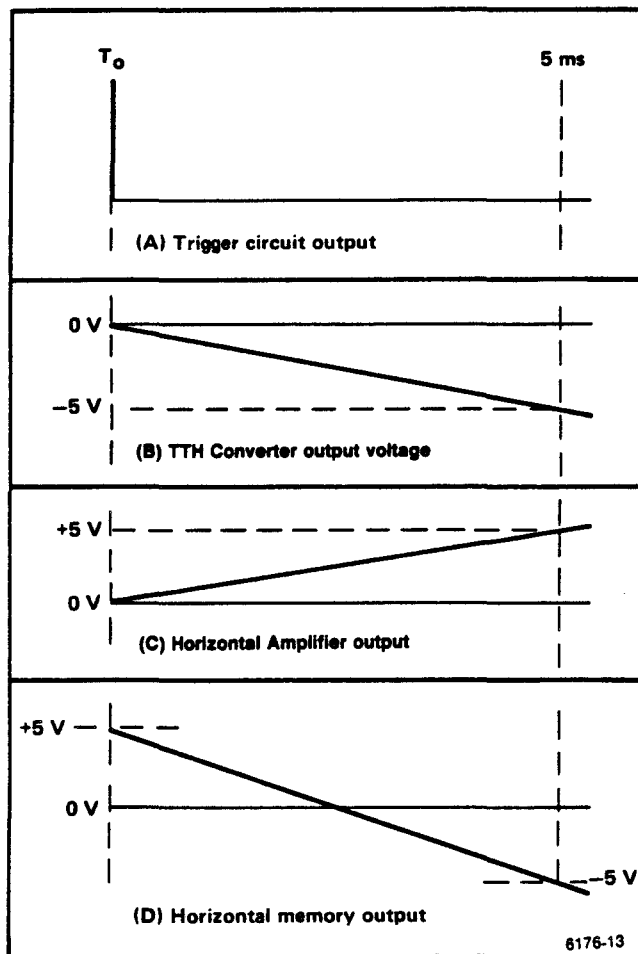

Figure 3-3. Circuit waveforms at control settings shown in Figure 3-1.

During the sweep illustrated in Figure 3-4, strobe pulses are shown occurring 10, 30, 50, 70 and 90  $\mu\text{s}$  after sweep triggering. Vertical samples taken at these times would be displayed 13, 33, 53, 73 and 93  $\mu\text{s}$  after sweep start. No fixed time relationship exists between the triggering point on the signal and the occurrence of the first strobe. This is ensured by frequency modulating the 50 kHz Real-Time Oscillator, which determines strobe timing, at an approximate 200 Hz rate. Frequency specifications for the Real-Time Oscillator are given in Section 1 of the Sampling Unit Instruction Manual.

The time interval, between trigger recognition ( $T_0$ ) and the first strobe, varies in value from 0  $\mu\text{s}$  to 20  $\mu\text{s}$ , so all parts of a repetitive signal will be sampled after a number of sweeps have occurred. When a sweep occurs in which the first strobe is at trigger recognition ( $T_0$ ), the triggering point

of the signal will be displayed approximately 3  $\mu\text{s}$  after sweep start. Unless the sweep repetition rate is very slow, the persistences of the CRT phosphor and the viewer's eye result in a display of samples taken during more than one sweep. This gives the sweep a more continuous appearance.

### Samples/Division Using Real-Time Sampling

In Figure 3-4, samples are being taken at 20  $\mu\text{s}$  intervals and the ramp voltage is changing at an average rate of 2 mV/ $\mu\text{s}$ . The displayed output of the Horizontal Memory therefore changes in 40 mV steps. The CRT is blanked during the shaded 3  $\mu\text{s}$  intervals. Each time the CRT is unblanked, a spot appears 1/25th of a division to the right of its previous position. One sweep consists of 250 dots or samples. The amplitude of the first step in the Horizontal Memory output, as well as its distance from sweep trigger and the first strobe.

Since the dots on the CRT, representing samples taken, occur at 20  $\mu\text{s}$  intervals, increasing the sweep rate by positioning the TIME/DIV control to a more clockwise setting increases the horizontal distance between samples. Fewer samples per sweep will therefore be displayed. Counterclockwise rotation of the SWEEP RANGE control selects faster ranges. Rotating the SWEEP RANGE control counterclockwise steepens the TTH ramp, increasing the amplitude of the Horizontal Memory Output voltage steps and reducing the number of steps required to move the sweep ten horizontal divisions.

### Summary of Real-Time Basic Block Diagram

The basic block diagram for Real-Time (Figure 3-1) shows a system very similar to a standard real-time oscilloscope. The arrival of a trigger starts the timing ramp, or Time to Height (TTH) Converter. The 50 kHz Real-Time Oscillator supplies strobe pulse to the Real-Time Multivibrator every 20  $\mu\text{s}$ . When a strobe occurs, the Real-Time Multivibrator fires, causing the Memory Gate to conduct for about 3  $\mu\text{s}$ . The CRT is blanked by the Interdot blanking circuit during this 3  $\mu\text{s}$  period. The memory tracks along with the amplified TTH ramp until the gate quits conducting. The CRT is then unblanked and the memory voltage remains constant until the next memory gating pulse arrives approximately 17  $\mu\text{s}$  later. The width of the memory gating pulse sets the lead time of the instrument. During Real-Time sampling this lead time is about 3  $\mu\text{s}$ . For each triggering event, one sweep across the screen is produced. The display created during each sweep consists of a series of dots spaced at 20  $\mu\text{s}$  intervals. At the faster real-time sweep rates the number of dots displayed per sweep decreases.

**Additional Real-Time Circuits**

Figure 3-2 shows a number of circuits and controls that did not appear in the basic block diagram of Figure 3-1. The additional circuit blocks are: Start Multivibrator, Reset Comparator, and HOMV (hold-off multivibrator). Operating controls shown on this block diagram are: SWEEP RANGE, TIME/DIV, and TIME POSITION.

The block labeled Trigger in Figure 3-1 is labeled Trigger and Output TD in Figure 3-2. This block represents all circuits through which the triggering signal passes before arriving at the Trigger Output tunnel diode. The time at which the trigger signal causes the Trigger Output TD to fire is referred to as trigger recognition or time  $t_0$ . The Trigger circuit switches the Start Multivibrator circuit, which in turn

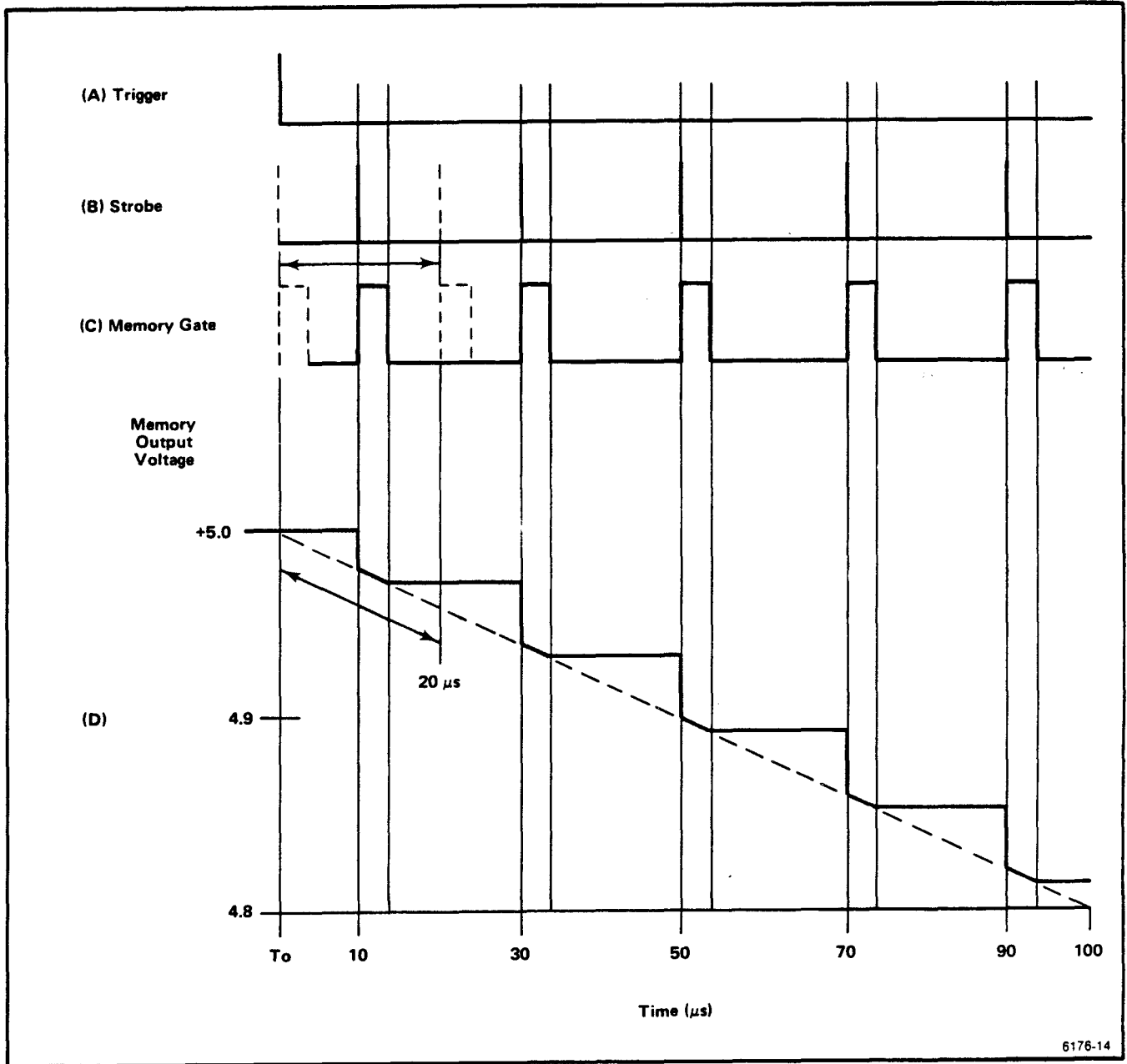

Figure 3-4. Timing relationships during the first 1/50th of one typical Real-time sweep. 7T11A control settings as given in Figure 3-1.

sends a start pulse to the TTH Converter. The Start Multivibrator also determines when Real-Time Retrace blanking operates. The Reset Comparator is provided to stop the rise in the Horizontal Amplifier output voltage when the voltage reaches a value of about +5.2 volts. When the output voltage of the Horizontal Amplifier reaches the reset value, the Reset Comparator produces an output that causes the HOMV to reset the Trigger and TTH circuits. This ends the sweep and provides Real-Time Retrace blanking.

The HOMV prevents triggering until the sweep has ended and adequate holdoff time has been provided for the TTH Converter to recover. The HOMV then resets permitting trigger recognition.

### Controls Affecting Timing and Delay

**SWEEP RANGE Control.** The Sweep Range control determines the basic timing of the 7T11A and the available amount of Time Positioning Range. The rate of change, or slope, of the TTH ramp changes by a factor of ten as the SWEEP RANGE control is rotated between positions.

Figure 3-5 shows the rate of change of the TTH Converter output voltage for the three Real-Time Sweep Ranges. It should be noted that a different time scale is used in Figure 3-5 for each of the ranges. The second ramp is ten times as fast as the first, and the third range provides a ramp that is ten times as fast as the second. The TTH ramp voltage runs from 0 volts to -5 volts in a time interval equal to ten times the slowest available TIME/DIV setting.

**TIME/DIV Control.** Figure 3-2 shows that the TIME/DIV control operates on the Horizontal Amplifier block. Changing the setting of the TIME/DIV control changes the gain of the Horizontal Amplifier and thereby changes display magnification. Display magnification varies from X1 to X500 depending upon the location of the TIME/DIV setting within the window provided on the front panel control. Refer to Figure 2-6 in the Operating Instructions section of this manual.

Display magnification is X1 at the slowest TIME/DIV setting available on each of the seven positions of the SWEEP RANGE control. At TIME/DIV settings providing X1 magnification, a 5 volt change in the TTH Converter output will cause the output of the Horizontal Amplifier to change 5 volts. At TIME/DIV settings providing greater than X1 magnification, less than 5 volts is required at the Horizontal Amplifier input to obtain a 5 volt output.

With the SWEEP RANGE control in the 5 ms/div to 10  $\mu$ s/div position and the TIME POSITION control fully CW, switching the TIME/DIV control from 5 ms/div (as shown in Figure 3-5) to 1 ms/div results in only the first 10 ms of the TTH ramp being used. During this time interval the TTH ramp will run from 0 volts down to -1 volt. This change in TIME/DIV setting changes the Horizontal Amplifier gain from 1 to 5. The 1 volt change at the TTH Converter output will end up as a 10 volt change at the memory output and therefore 10 divisions of horizontal deflection on the CRT. Magnification is X5.

**TIME POSITION Control.** Figure 3-2 shows that the TIME POSITION control also operates on the Horizontal Amplifier block. Essentially the TIME POSITION control delays the start of the magnified linear sweep delivered to the Horizontal Memory Gate. See Figure 3-6.

The TIME POSITION control determines the time separation between the start of the TTH ramp and the start of the ramp from the Horizontal Amplifier. With the control settings given in Figure 3-6, TIME POS RNG is 50 ms. Figure 3-6A shows the time relationship of the TTH Converter and Horizontal Amplifier outputs with the TIME POSITION control fully clockwise, while Figure 3-6B shows the time relationship with TIME POSITION fully counterclockwise. Any value of delay between that shown in Figure 3-6A and 3-6B is available at intermediate positions of the TIME POSITION control.

In Figure 3-6C the TIME POSITION control is set to mid-position and the TIME/DIV control has been switched from 5 ms/div to 1 ms/div (X5 Mag). Before the arrival of the Trigger, the output of the TTH Converter and the Horizontal Amplifier is at zero, and the Horizontal Memory output is at +5 volts; the dot is blanked. The arrival of a trigger pulse starts the TTH ramp running negative. The Horizontal Amplifier still remains at zero until the TTH Converter output voltage passes -2.5 volts; its output then rises positive 1 volt per 2 ms. The Horizontal Memory follows this amplified and delayed ramp in the form of a staircase, stepping nega-

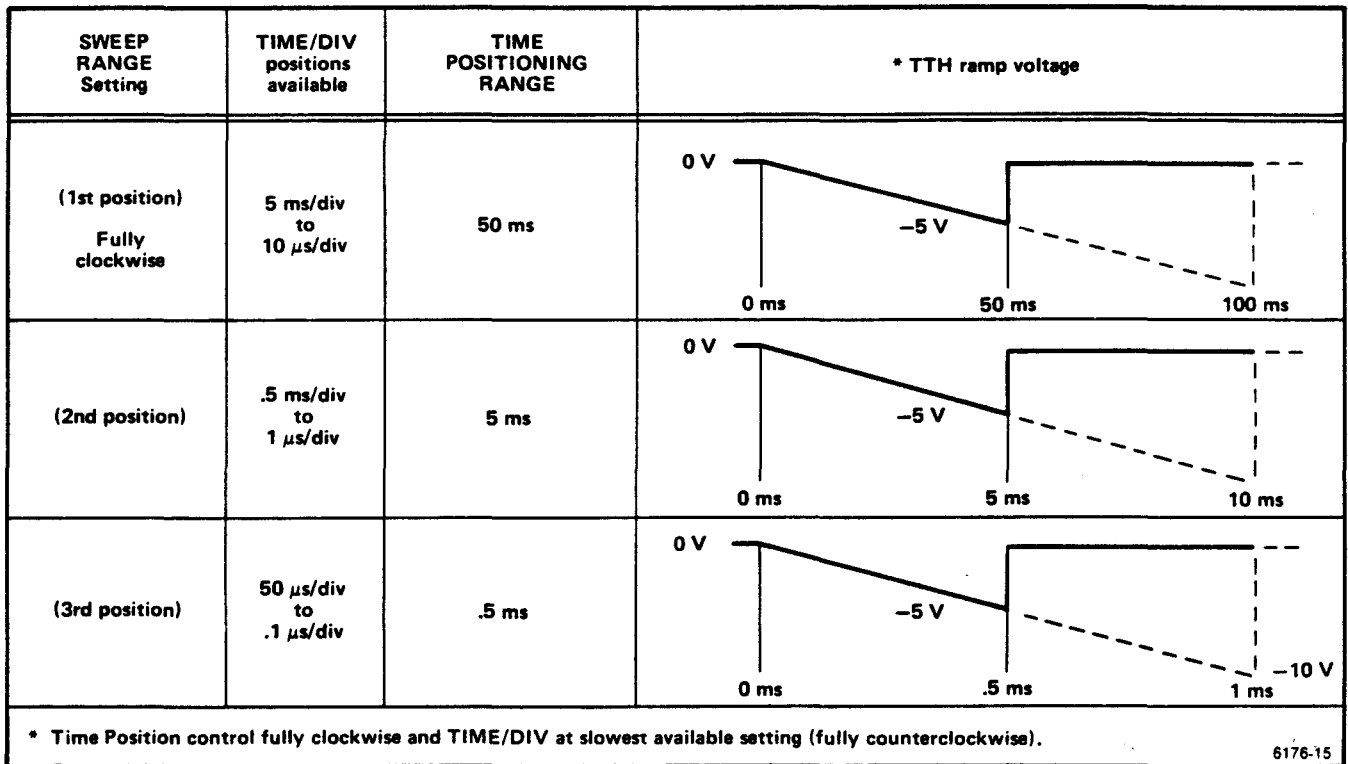

Figure 3-5. TTH ramp voltage versus time at the three Real-time positions of the SWEEP RANGE control.

tive as the strobos arrive. The sweep continues until the output of the Horizontal Amplifier reaches a voltage of approximately +5.2 volts. Then the Reset Comparator operates, resetting the HOMV, Trigger, and TTH Converter circuits.

### Important Waveform Relationships

Assume that the TTH Converter has recovered from the previous sweep and that Trigger Output TD (tunnel diode) is armed and ready to be triggered. The arrival of a suitable triggering signal causes the output TD to switch to its high state at a time designated as  $T_0$  on Figure 3-7. When the Output TD switches, it causes a positive pulse to appear at the front panel PULSE OUT connector. This positive pulse ends when the output TD returns to its low state. Switching of the Output TD also causes a signal to be sent through trigger output and coupling circuits to the Start Multivibrator, which starts the negative-going TTH ramp.

Strobe pulses are occurring at intervals of approximately 20  $\mu$ s; causing sampling of the vertical signal, gating of the Horizontal Memory, and Interdot blanking for a period of about 3  $\mu$ s out of each 20 microseconds (see Figure 3-4).

While the Output TD is at its high level, the Start Multivibrator is held ON. With the Start Multivibrator ON, retrace blanking is disabled and blanking is controlled by the Interdot and Overrun blanking circuits.

After an interval of time determined by an RC circuit in an input to the A section of the HOMV, outputs of HOMV sections A and B switch (see Figure 3-7). This switching occurs at a time referred to as 1/2 hold-off interval and occurs approximately 1 ms after  $T_0$  on the three Real-Time Sweep Ranges. The switching of HOMV sections A and B result in one of the C inputs rapidly rising to the level required to switch the outputs of HOMV sections C and D. Sections C and D will not switch, however, until both C inputs are at the required positive level.

The output of the Horizontal Amplifier does not start rising until 2.5 ms after  $T_0$  since the conditions stated on Figure 3-7 specify that 2.5 ms of time positioning is in use. During the time interval from 2.5 ms to 7.7 ms after  $T_0$ , the Horizontal Amplifier output changes from 0 volts to approximately +5.2 volts. When the output of the Horizontal Amplifier reaches about +5.2 volts the Reset Comparator drives the other section C input (pin 9) positive. The C section output of the HOMV switches, causing the D section to switch.

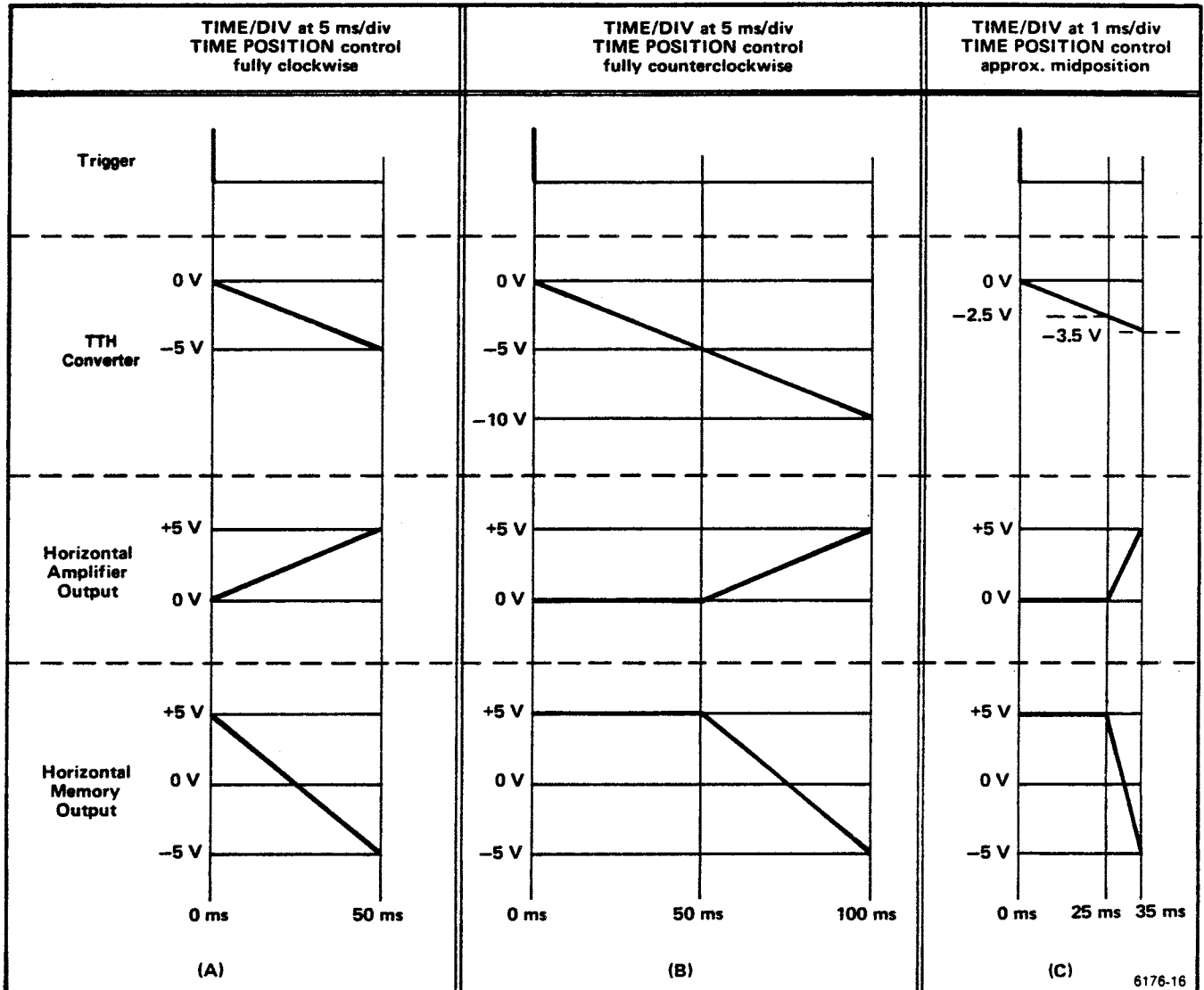

6176-16

Figure 3-6. Effect of TIME POSITION and TIME/DIV controls. SWEEP RANGE set at 5 ms/div to 10 μs/div position.

When the D output of the HOMV switches (shown at 7.7 ms on Figure 3-7) it causes switching of the Trigger Output TD to its low level. This causes the Start Multivibrator to shut off; this ends the TTH ramp, permits retrace blanking to operate, and ends the output from the PULSE OUT connector.

After an interval of time (1/2 hold-off interval) determined by the RC previously mentioned, HOMV Sections A, B, C and D return to their quiescent state (8.7 ms after  $T_0$  on Figure 3-7). The Arming and Output TD's are now returned to a ready-to-fire condition. The next incoming trigger (10 ms in Figure 3-7) will be recognized and the cycle repeats.



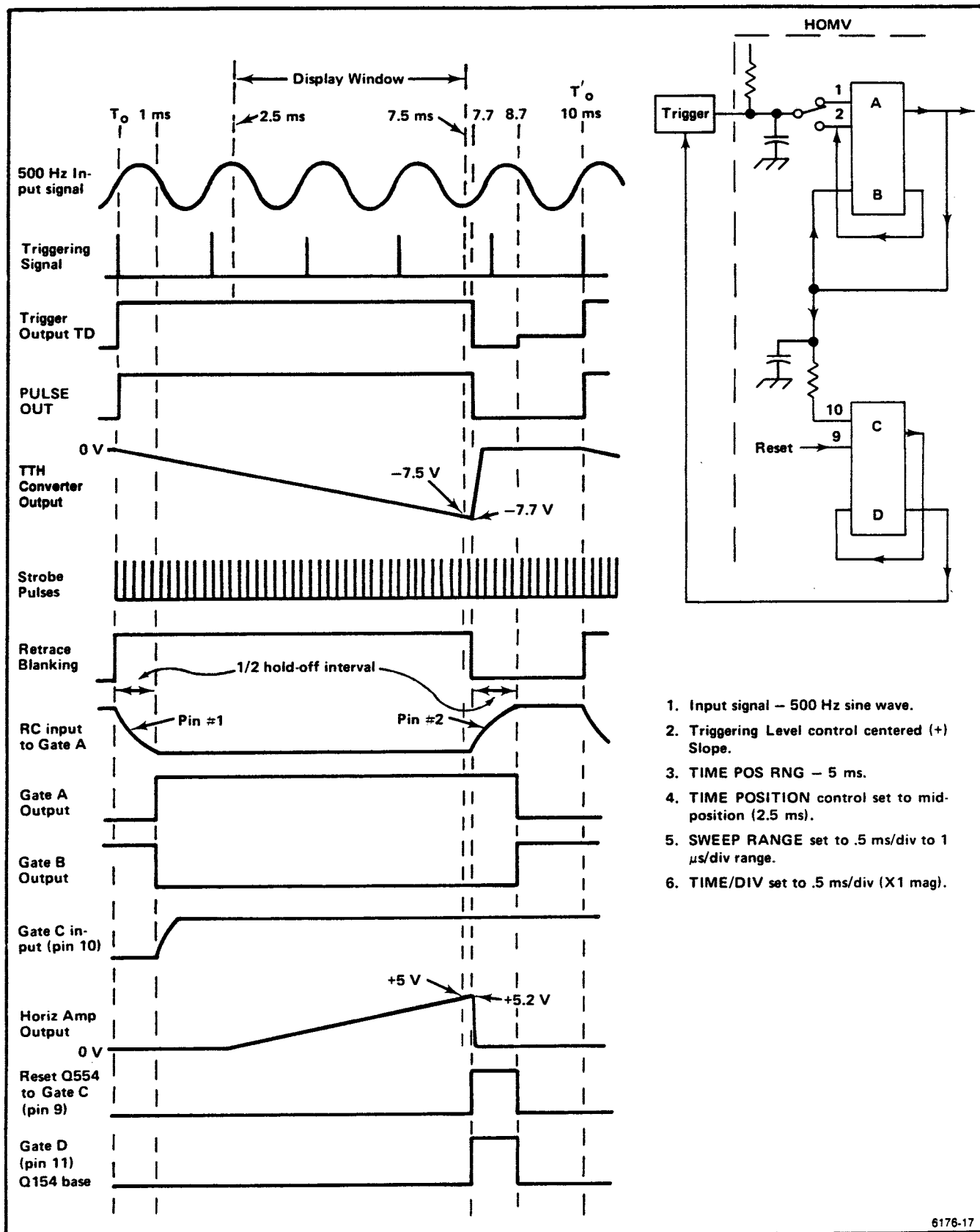

1. Input signal – 500 Hz sine wave.
2. Triggering Level control centered (+) Slope.
3. TIME POS RNG – 5 ms.
4. TIME POSITION control set to mid-position (2.5 ms).
5. SWEEP RANGE set to .5 ms/div to 1  $\mu$ s/div range.
6. TIME/DIV set to .5 ms/div (X1 mag).

Figure 3-7. Ideal Trigger, Sweep, and HOMV waveform relationships during real-time sampling.

6176-17

The minimum hold-off time on the three real-time ranges is approximately equal to the sum of the two 1/2 hold-off intervals (a total of about 2 ms). At the slower real-time sweep rates or when time positioning is used, hold-off time increases and the maximum triggering rate therefore decreases.

## SEQUENTIAL EQUIVALENT-TIME SAMPLING

### Additional Circuits Required

Figure 3-8 shows a simplified block diagram of circuits required for sequential equivalent-time operation of the 7T11A. Comparison of Figure 3-8 with the real-time block diagram shown in Figure 3-2 shows that the Reset Comparator and Real-Time Multivibrator are not used during equivalent-time operation.

Additional circuits (shown in Figure 3-8), required during sequential operation are: Slewing Ramp, Slewing Comparator, Slow Ramp Generator, Slow Ramp Inverter, Dot Position Comparator, and Dot Position Memory.

**Slewing Ramp.** The Slewing Ramp is a fast ramp that is started at the same time as the TTH ramp and runs negative at the same rate. Its slope is determined by which of the four equivalent-time Sweep Ranges is selected. The output of the Slewing Ramp is fed to one input of the Slewing Comparator, where its voltage is compared to the inverted output of the Slow Ramp Generator.

**Slow Ramp.** The Slow Ramp Generator output, after passing through the Slow Ramp Inverter, provides an input reference voltage to the Slewing Comparator against which the output of the Slewing Ramp is compared.

The output of the Slow Ramp Generator rises from 0 volts to slightly more than +10 volts and is then reset by a reset multivibrator. After a short hold-off interval, a negative-going output of the HOMV is able to again shut off the reset multivibrator, permitting generation of another slow ramp.

The rate of rise and therefore the time required to generate the Slow Ramp is controlled by the SCAN control. On equivalent-time ranges and with REP SCAN selected, the SCAN control permits controlling the dot density of the display.

**Slow Ramp Inverter.** The Slow Ramp Inverter inverts the Slow Ramp output. The negative-going output of the Inverter is applied to the Slewing Comparator.

The TIME POSITION control introduces offset to the Slow Ramp Inverter input to compensate for the offset introduced into the Horizontal Amplifier by the Time POSITION control. Unless this is done the TTH ramp could be stopped by the comparator before any change in voltage appeared at the output of the Horizontal Amplifier.

**Slewing Comparator.** The purpose of the Slewing Comparator is to compare the output of the Slewing Ramp with the output of the Slow Ramp Inverter. When these two inputs to the comparator are equal, the comparator delivers an output. The Slewing Comparator output initiates the strobe pulses that are delivered to the vertical unit sampling heads and cause them to sample the input signals. The Slewing Comparator output also stops the negative-going TTH ramp. This stopped level is then amplified and read into the Horizontal Memory at 1/2 hold-off time.

**Dot Position Comparator and Memory.** Factors determining the timing and linearity of the CRT display are the cleanliness of the TTH Converter, Horizontal Amplifier, Horizontal Memory, and output circuits. The nonlinearities and distortions present in the Slewing Ramp, Slewing Comparator, and Slow Ramp circuits do not affect display timing and linearity. The independence of these two groups of circuits cause the timing of the output from the Slewing Comparator to be critical.

If the Horizontal Amplifier is set to a magnification ratio of 50, a 0.1 volt excursion of the TTH ramp shows up as a 10 volt excursion at the output of the Horizontal Memory. Also, the Time Position control can be set so that the TTH Converter must go through an excursion of 5 volts before the Horizontal Amplifier becomes operative. It is this situation that makes the timing of the Slewing Comparator output very critical.

Since the timing of the Slewing Comparator output sets the output level of the TTH Converter, and since this firing is dependent upon the programmed level set by the Slewing Ramp, Slewing Comparator, Slow Ramp, and Slow Ramp Inverter, it is easy to see that a few millivolts of programming error can cause the TTH ramp to be stopped at a level corresponding to an off screen dot position. The Dot Position Comparator and Dot Position Memory are provided to prevent this programming error.

The Dot Position Comparator compares the voltage from the Horizontal Memory (via the Output Amplifier) with the Slow Ramp voltage. If the Memory voltage is not at the



correct level, an error signal causes the Dot Position Memory to shift level. This new DC level is fed back to the Slow Ramp Inverter to slide the next sample closer to the correct position. Care is taken to make the strobe slewing and the TTH Converter system track each other, so only a small position error remains to be corrected by the Dot Positioning circuits.

### Constructing the Display

One major difference between real-time and equivalent-time sampling in the 7T11A is the manner in which the display is constructed on the CRT. During real-time operation many samples of the vertical input signal are normally taken during one horizontal sweep. During equivalent-time operation only one sample of the vertical input signal is taken and one dot is displayed for each input trigger. In Figure 3-9, ideal waveforms are shown for the 7T11A sequential equivalent-time sampling.

Each time a trigger is recognized (time  $T_0$ ) a new TTH Converter sweep is generated. When the output level of the fast ramp generator (the Slewing Ramp) equals that of the Slow Ramp Inverter, a sampling head strobe pulse is generated and the vertical input signal is sampled. The signal amplitude is stored in the vertical memory. The CRT is blanked when the strobe occurs and the change in TTH Converter output voltage is stopped.

The TTH Converter voltage, after passing through the Horizontal Amplifier and the X2 gain of the Horizontal Memory, is stored in the Horizontal Memory by turning on the Memory Gate for approximately  $2 \mu\text{s}$  at the  $1/2$  hold-off time. The CRT is then unblanked, permitting display of a dot at a position determined by the voltages stored in the vertical and horizontal memories. After a suitable hold-off interval, determined by the HOMV, the circuits are returned to normal and another triggering signal can be recognized.

When the next trigger signal is recognized (shown at  $25 \mu\text{s}$  in Figure 3-9) the TTH ramp and Slewing Ramp again start running negative at the same rate. Since the output voltage of the Slow Ramp is continuously changing at a slow rate the Slewing Ramp must run slightly more negative this time. The strobe pulse therefore occurs at a slightly later time with respect to trigger recognition ( $T_0$ ).

Each sample results in the display of a dot slightly to the right of the dot representing the preceding sample. This increase in delay between  $T_0$  and the strobe pulse continues until dots have been placed horizontally completely across the CRT. The Slow Ramp resets and another equivalent-time display is then started at the left of the CRT and progresses slightly to the right at each sample as the process repeats.

The number of recognized triggers required to construct one equivalent time sweep is dependent upon how close together horizontally the samples are spaced. This is dependent upon dot density or samples per sweep. The SCAN control permits changing the Slow Ramp slope and thereby changing dot density.

### Waveform Relationships

Figure 3-9 shows ideal waveform relationships for sequential equivalent-time sampling. Minimum trigger hold-off time for the three fastest equivalent time ranges is at least  $25 \mu\text{s}$ . The HOMV will not permit triggering at intervals of time closer than  $25 \mu\text{s}$  regardless of the input trigger repetition rate. For purposes of explanation, triggering is at  $25 \mu\text{s}$  intervals, and the following control settings are assumed:

TIME POSITION	fully clockwise
SWEEP RANGE	$.5 \mu\text{s}/\text{div}$ to $1 \text{ ns}/\text{div}$
TIME/DIV	$.5 \mu\text{s}/\text{div}$
SCAN	adjusted to $50,000 \mu\text{s}$ per sweep (about a 20 Hz rate)

When the Output TD switches to its high state at time ( $T_0$ ), the TTH ramp and Slewing Ramps start running negative at the same rate. The Slow Ramp is assumed to have started its run from 0 volts to +10 volts  $25,000 \mu\text{s}$  previously and has completed  $1/2$  of its positive run. The Slow Ramp output is therefore +5.0 volts. At the control settings given above, the Horizontal Amplifier gain is X1 and therefore no attenuation is introduced at the Slow Ramp Inverter input. The Slow Ramp Inverter gain is set at 0.5 so the +5 volt input signal will appear as a -2.5 volt signal at the output. The -2.5 volt output of the inverter is fed to one input of the comparator. When the Slewing Ramp output voltage applied to the comparator reaches a value equal to that applied by the Slow Ramp Inverter, the comparator output goes positive.

The comparator output stops the negative-going TTH ramp and prevents the Slewing Ramp from going below the level of the Slow Ramp. At the same time the comparator enables the 7T11A Interdot blanking and causes a strobe pulse to be sent to the sampling head(s) in the Sampling Unit plug-in(s). This is shown occurring at  $2.5 \mu\text{s}$  after  $T_0$  in Figure 3-9. The sampling head(s) sample the input signals and the signal amplitudes are stored in the vertical memories. No spot will appear on the CRT at this time since the Interdot blanking is operative.

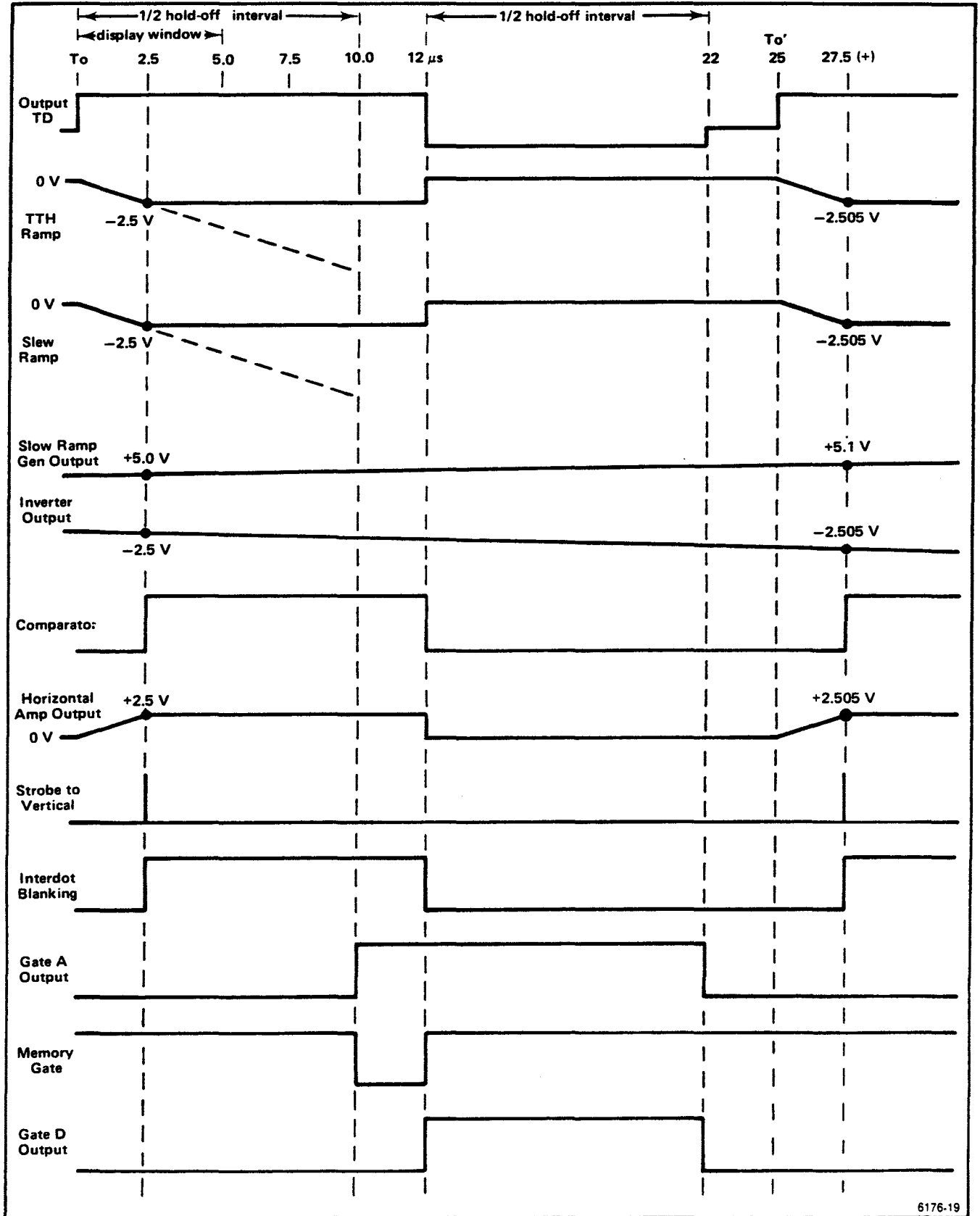

6176-19

Figure 3-9. Ideal waveform relationships during sequential equivalent-time sampling.

## Theory of Operation—7T11A

After an interval of time determined by an RC circuit in the HOMV, the A output of the HOMV switches to a more positive level. This switching occurs at a time referred to as 1/2 hold-off interval and is shown occurring at 10  $\mu\text{s}$  in Figure 3-9. This 10  $\mu\text{s}$  is the absolute minimum time duration that will permit a full 10 division sweep at a TIME/DIV setting of .5  $\mu\text{s}/\text{div}$  and with the full 5  $\mu\text{s}$  of available time positioning range in use. The actual value of 1/2 hold-off interval must therefore be somewhat longer than the 10  $\mu\text{s}$  shown.

Switching of HOMV section A causes the Horizontal Memory Gate to be turned on. The -2.5 volt level of the TTH ramp appears at the Horizontal Amplifier output as a +2.5 volt level, and at the Horizontal Memory output as a 0 volt output level. These voltage relationships are illustrated in Figure 3-3.

After an interval of about 2  $\mu\text{s}$ , as determined by a second RC circuit in the HOMV, the D output of the HOMV switches to its high level. See Figure 3-9. Gate D, shown as switching at 12  $\mu\text{s}$  after  $T_0$ , ends the Horizontal Memory gating pulse. Interdot blanking is disabled and a dot appears on the CRT at a position determined by the voltage level stored in the vertical and horizontal memories. Since the Horizontal Memory output voltage is now 0 volts, the dot is positioned at the horizontal midposition (at the 2.5  $\mu\text{s}$  position on the display).

The switching of HOMV section D (12  $\mu\text{s}$  after  $T_0$ ) also causes the Output TD to return to its low state and the TTH Converter, Slewing Ramp, and Horizontal Amplifier outputs to return to their 0 volt level. After another interval of at least 10  $\mu\text{s}$  (1/2 hold-off interval) the HOMV permits rearming of the Output TD to a "ready-for-trigger" condition.

In Figure 3-9 triggering is shown to occur again at 25  $\mu\text{s}$  and the cycle repeats. Since the Slow Ramp voltage is steadily rising toward its 10 volt limit, the Slow Ramp voltage is slightly more positive than at the previous  $T_0$  and the Slewing Ramp must run more negative before the comparator output again occurs. The output of the Horizontal Memory is now -10 mV when unblanking occurs, instead of the 0 volts present following the previous  $T_0$ . A dot appears on the CRT positioned 1/100th of a division to the right of the previous dot.

Ideally, if triggering continues to occur at 25  $\mu\text{s}$  intervals, dots will continue to be placed 1/100th of a division to the right of the previous dot at intervals of 25  $\mu\text{s}$  until the Slow Ramp reaches its approximate +10 volt limit. When the Slow Ramp reaches +10 volts, the Reset Multivibrator provides retrace blanking and resets the Slow Ramp to zero. After a hold-off interval, the Slow Ramp can again be started.

Turning the TIME POSITION control fully CCW affects the waveforms (of Figure 3-9) as shown in Figure 3-10. With the full 5  $\mu\text{s}$  of available time positioning in use, the time interval from 5  $\mu\text{s}$  to 10  $\mu\text{s}$  after  $T_0$  is displayed.

The Time Position control provides an offset current to the Slow Ramp Inverter input that causes the Inverter output to be shifted negative by 5 volts. If at the time indicated as 7.5  $\mu\text{s}$  on Figure 3-10, the Slow Ramp Generator is delivering +5 volts to the Inverter input, this signal will appear as an additional -2.5 volt signal at the output. Adding this -2.5 volt signal to the -5 volts produced by the Time Position control results in a -7.5 volts at the Inverter output.

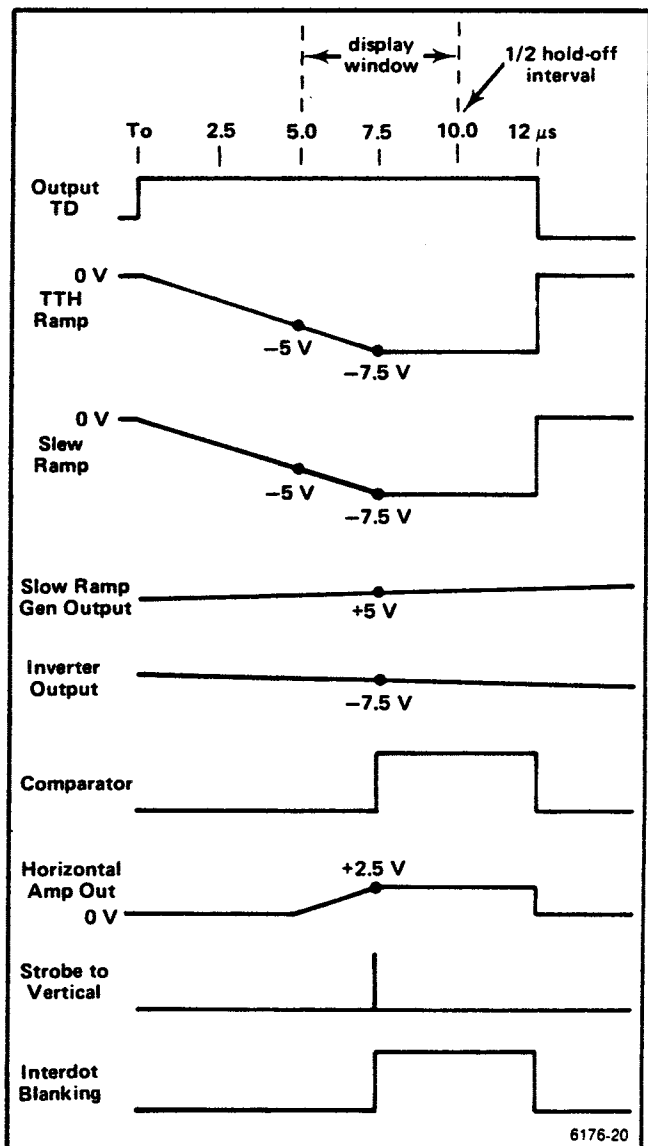

Figure 3-10. Effect of turning TIME POSITION control fully CCW on waveforms of Figure 3-9.

### Factors Affecting Dot Density

On the three fastest equivalent-time sweep ranges, the triggering interval can be no less than about 25  $\mu$ s. As the trigger repetition rate is reduced so that the interval between triggers is more than 25  $\mu$ s, a reduction in dot density becomes apparent. This is because the dot density is dependent on the amount of change in the Slow Ramp voltage. An interval longer than the 25  $\mu$ s minimum triggering interval permits a greater change in the slow ramp voltage and therefore increased dot spacing.

Switching the Sweep Range control between the three fastest equivalent-time ranges has no noticeable effect on samples taken per sweep, but when the slowest equivalent-time Sweep Range (5  $\mu$ s/div to 10 ns/div) is selected, the HOMV range capacitor is changed. The HOMV now permits triggering at intervals no closer than 200  $\mu$ s. Since the slow ramp voltage will change more in 200  $\mu$ s than in 25  $\mu$ s, if triggers are arriving at intervals closer than 200  $\mu$ s, switching from one of the three fastest equivalent-time ranges to the slowest equivalent-time sweep range reduces the dot density.

Changing the setting of the TIME/DIV control has no effect on dot density because an attenuator network, controlled by the TIME/DIV control, reduces the slope of the signal delivered to the Slow Ramp Inverter by the same factor as Horizontal Amplifier gain is increased. Also, dot density is not affected by rotation of the VARIABLE time per division control. Rotation of the VARIABLE control clockwise increases Horizontal Amplifier gain while reducing input to the Slow Ramp Inverter by the same factor.

Assume that the TIME/DIV control is at a position where Horizontal Amplifier gain is X1. The entire 5 volt output of the TTH Converter will be used by the Horizontal Amplifier. Assuming 1000 samples per sweep, samples are taken at 5 mV intervals along the TTH ramp. With the TIME/DIV control at a setting providing X10 Horizontal Amplifier gain, only 0.5 volts of the TTH ramp is used to produce 10 divisions of horizontal deflection. In order to maintain the dot density (1000 samples/sweep was assumed) samples must be taken at  $0.5/1000 = 0.5$  mV intervals along the TTH ramp rundown. This is accomplished by reducing the rate of change of the slow ramp at the inverter input to one-tenth of its former value, using the attenuation network mentioned above.

In summary; the SCAN control affects dot density. Dot density may also be affected by the trigger repetition rate or by switching from one of the three fastest equivalent-time Sweep Ranges to the slowest equivalent-time Sweep Range. Dot density is not affected by switching from one TIME/DIV setting to another.

### Blanking

Four types of blanking are used in the 7T11A. Inputs to the blanking circuits are provided via the interface connector to allow mainframe logic circuits the ability to determine when CRT blanking may occur. The four types of blanking used in the 7T11A are: Interdot, Overrun, Real-Time Retrace, and Slow Ramp Retrace (see Figure 3-11). The first two types, Interdot and Overrun, are used during both real- and equivalent-time sampling. Real-Time Retrace blanking is used only during real-time sampling and Slow Ramp Retrace is used only during equivalent-time operation.

The purpose of Interdot blanking is to blank the CRT until the voltages representing the latest TTH Converter and vertical signal sample are stored in their respective memories. Figure 3-4 shows that during real-time operation, Interdot blanking occurs at the time a strobe pulse is delivered to the vertical unit and the Horizontal Memory is gated on. Figure 3-9 shows that during equivalent-time operation, Interdot blanking starts at the time of the vertical strobe pulse and ends when the horizontal memory gating pulse ends.

Overrun blanking prevents the display of a dot if either of the push-pull outputs of the Horizontal Amplifier exceeds +5 volts. This prevents display of undesirable parts of the sweep.

Both Real-Time Retrace and Slow Ramp Retrace blanking prevent the user from seeing the retrace portion of the sweep. Retrace blanking keeps the CRT blanked from the time the sweep ends until a new sweep starts.

The logic shown in Figure 3-11A includes a peak detector. At normal trigger repetition rates the peak detector delivers a signal that permits normal operation of all four types of blanking. If a period of more than one or two seconds elapses between triggers, the output of the peak detector is lost and all blanking is disabled.

No sweep is present in the absence of triggers and if the CRT is blanked, the beam cannot be located using the oscilloscope beam finder. As explained above, blanking is disabled if more than a couple of seconds elapses between triggers and the beam finder will then function.

Retrace blanking is provided for use by the oscilloscope mainframe Sweep Gate circuit. Interdot and Overrun blanking are provided to the mainframe Auxiliary Z-Axis circuit. This blanking circuit also provides for input from the mainframe Control Logic to ensure that the 7T11A may only blank the CRT during its allotted display time. An inverted version of the Z-Axis blanking signal is provided for use by the mainframe's Auxiliary Sweep circuit.

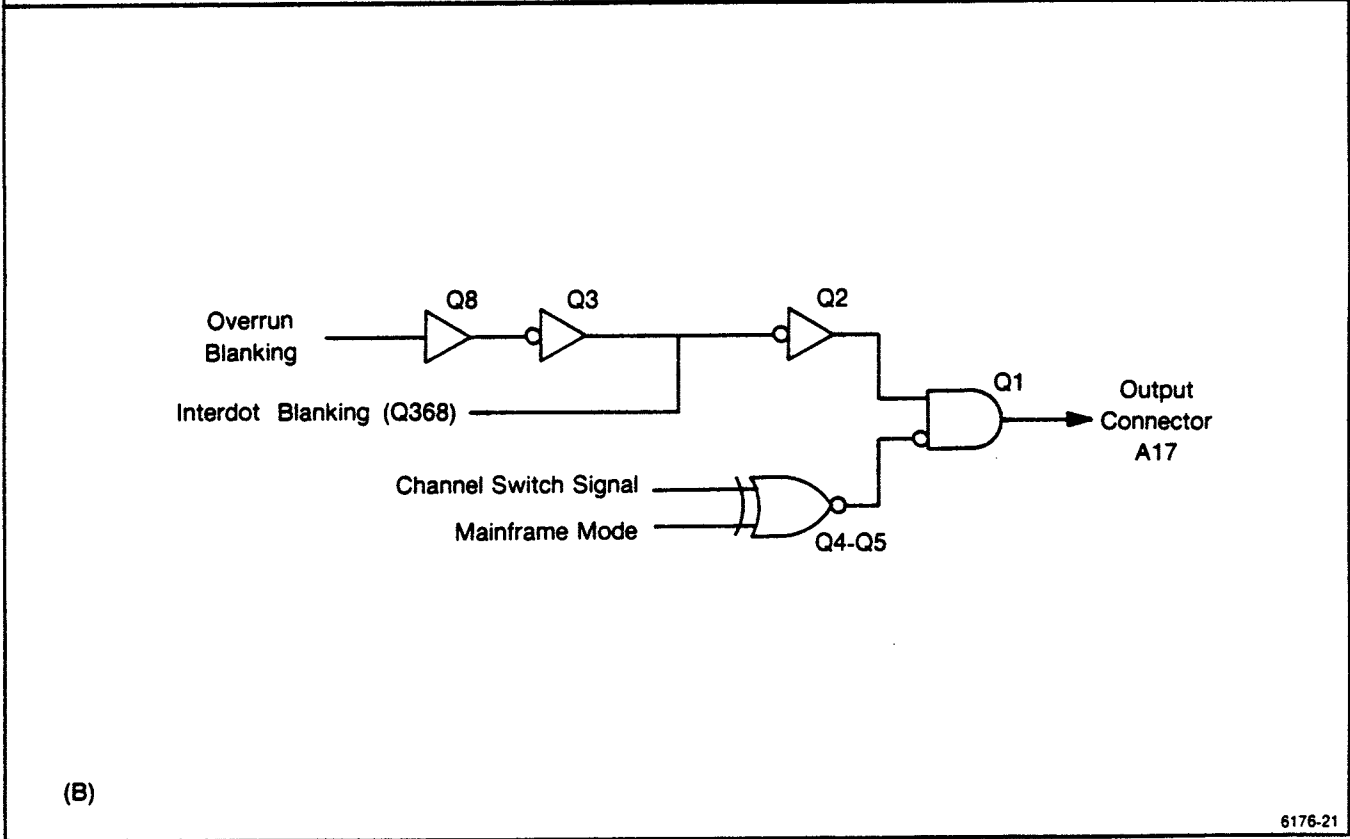
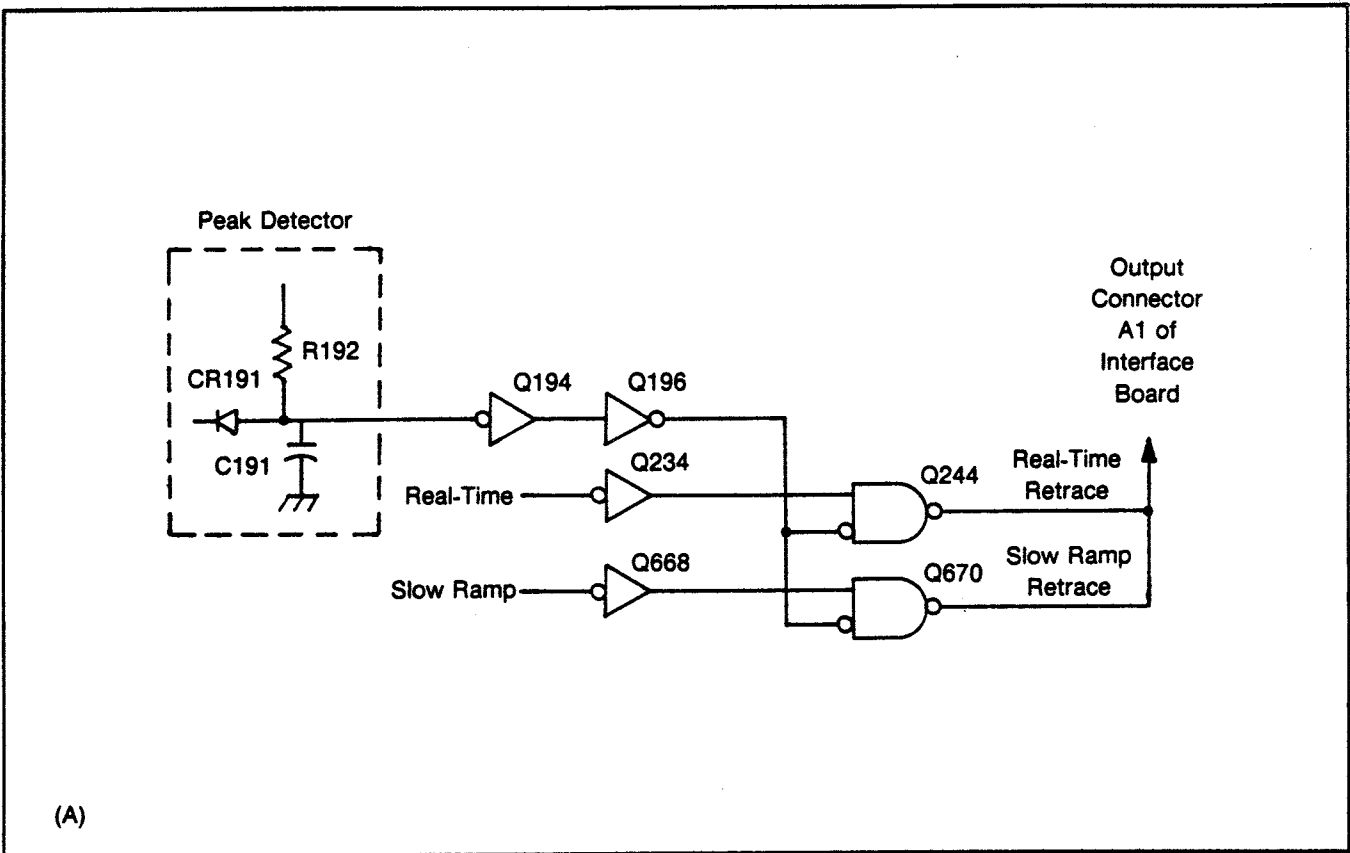

Figure 3-11. 7T11A Blanking Logic.



### Unavoidable Delay Introduced by the 7T11A

During sequential equivalent-time sampling a fast rise, low repetition-rate pulse cannot be displayed using Internal triggering. The reason for this is illustrated in Figure 3-12. With Triggering Level and Stability controls set to produce triggering as near as possible to the start of the pulse leading edge, some of the pulse leading edge occurs before the triggering level is reached and is therefore lost.

Another factor preventing display of the input signal leading edge is that triggering is not instantaneous. Time is required for the signal to travel to the trigger circuits and cause the Trigger Output TD to switch to its high state. By the time the Trigger Output TD switches (time  $T_0$ ), the signal illustrated in Figure 3-12 has reached its peak value. If a strobe pulse is delivered to the sampling bridge at this instant (time  $T_0$ ) none of the leading edge of the input pulse is displayed. The display window has been shifted to the right since its start is delayed by the same amount as  $T_0$  lags the triggering level.

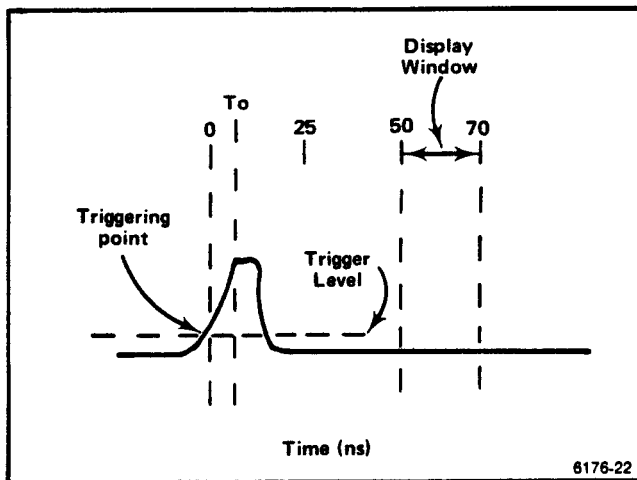

Figure 3-12. Unavoidable delay between trigger point on input signal and start of display window.

If the Slow Ramp is at zero, the Comparator should produce a strobe pulse at time  $T_0$  for delivery to the sampling heads. Some lag exists between  $T_0$  and production of the strobe pulse and additional time is required for the strobe to travel from the 7T11A to the Vertical Unit and thence to the sampling bridge. If the sampling head is operating on an extender cable, or a probe type sampling head is used, the travel time is further increased. The display window is shifted due to this travel time. In Figure 3-12 the display window is shown extending from 50 ns to 70 ns after the triggering level is reached. With the input signal shown, delivering strobe pulses to the sampling bridge during the interval from 50 ns to 70 ns will result in sampling the vertical input signal after it has returned to zero. A straight line will therefore be displayed horizontally across the CRT.

The display window can be moved further to the right on Figure 3-12 by further delaying the start of the sweep. Turning the Time Position control CCW increases the amount of delay between  $T_0$  and the start of the display window. If the time between input pulses is not too long and repetition rate is constant, a display can be created by triggering on one input pulse and delaying the display window so that the strobe pulses arrive at the sampling head coincident with the next input pulse. Setting the triggering level and slope controls for triggering on the trailing edge of the input pulse shown in Figure 3-12 reduces the delay (time positioning) required.

Two methods of starting the sweep and strobing the sampling heads before the input signal reaches the sampling bridges are discussed in Section 2 of this manual. The first method is to introduce delay in the vertical signal path between the signal source and the input to the sampling head. A 50  $\Omega$  delay line can be used for this purpose. The second method requires use of a signal source providing a Pretrigger. In both of these methods the trigger signal must be connected to the 7T11A External Trigger connector. Operation is satisfactory at both low and high trigger repetition rates and when the repetition rate is not constant.

## RANDOM EQUIVALENT-TIME SAMPLING

### Introduction

Random sampling permits display of the leading edge, or any other part, of the input signal shown in Figure 3-13. This is possible even when observing fast-rise, short duration pulses, and when using either internal or external trigger sources (EXT modes of triggering give better results in Random Sampling).

Not only the input signal leading edge, but also vertical inputs prior to the arrival of the triggering signal can be displayed. An example is shown in Figure 3-13, where the triggering is set for the (+) slope and at a triggering level above that of the first pulse. The pulse occurring prior to the trigger point is displayed.

Seeing before the triggering point is possible when using the 7T11A in Random mode due to the introduction of lead time. The effect of lead time is opposite to that produced by the Time Position control. Rotation of the Time Position control CCW increases the delay between trigger recognition (time  $T_0$ ) and the start of the display window. Lead time, however, moves the display window in the opposite direction. The effect of lead time is evident if the position of the display window is compared in Figures 3-12 and 3-13.

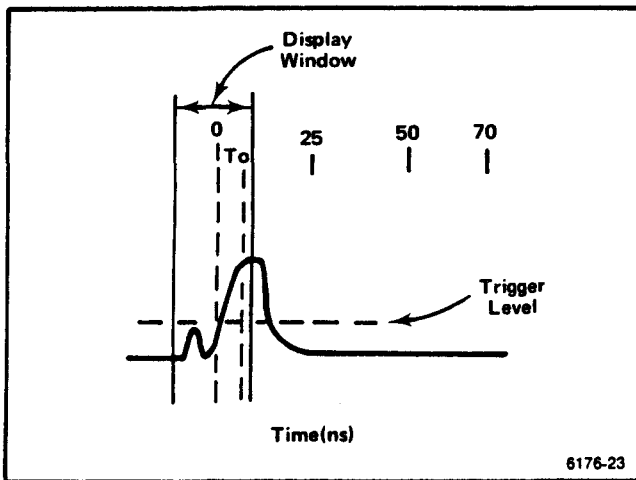

Figure 3-13. Effect of lead time in moving display window.

During Random mode operation, a lead time of approximately one-half the time positioning range (TPR) is introduced on all four equivalent-time sweep ranges. In addition, in the 5 ns/div to 10 ps/div sweep range, another 50 ns of lead time is introduced. Since the TPR is 50 ns, at this sweep range setting, a total of (1/2 of 50 ns + 50 ns) approximately 75 ns of lead time is introduced at the fastest sweep range setting.

Lead time results from the action of the Ratemeter circuit and the introduction of offset current to the input of the Horizontal Amplifier. The direction of lead time offset current is opposite to offset current introduced by the Time Position control.

### Random Mode Block Diagram

Comparison of Figure 3-14 with the Sequential Block diagram of Figure 3-8 shows that a number of blocks have been added. The additional blocks shown in Figure 3-14 are: Ratemeter, Lead Time Offset, Ratemeter Correction, and Start Correction Memory. Another difference between the Sequential and the Random block diagrams is that the Random block diagram shows a (+) stop input to the TTH Converter, and an OR logic symbol is shown at the TTH Converter input.

**Ratemeter.** The Ratemeter provides an output that permits the display window to include time prior to arrival of a signal at the sampling head as shown in Figure 3-13. The Ratemeter effectively determines the time between triggers. Two Ratemeter inputs are needed to determine this time

interval (see Figure 3-14). These two inputs are a reset pulse delivered by the HOMV (at 1/2 hold-off interval after  $T_0$ ), and an input delivered by the Trigger circuit at time  $T_0$ . The Ratemeter effectively measures the time between reset and the next trigger recognition ( $T_0$ ) and adds this time to the 1/2 hold-off time.

A third input to the Ratemeter is the DC correction. This input supplies the required lead time and correction to the timing of the Ratemeter output.

**Lead Time Offset.** The Leadtime Offset circuit causes the Ratemeter output to occur approximately 1/2 time positioning range (1 1/2 TPR on the fastest Sweep Range) sooner than it normally would. This lead time permits strobe pulses to be delivered to the sampling heads before arrival of the signal to be observed and therefore permits seeing before the triggering point. The Lead Time Offset also provides an offset voltage to the Horizontal Amplifier so that trigger recognition (time  $T_0$ ) is displayed at the approximate center of the display window.

**Ratemeter Correction.** The Ratemeter Correction circuit combines Lead Time Offset with the output of a comparator. This comparator is considered to be included in the Ratemeter Correction block of Figure 3-14. The comparator delivers an output if the output of the TTH Converter and the output of the Slow Ramp Inverter are unequal. The error voltage from the comparator is combined with the Lead Time Offset at the Ratemeter Correction output.

**Start Correction Memory.** The Start Correction Memory includes a gating circuit. When the HOMV delivers a strobe pulse to this gating circuit, the output of the Ratemeter Correction circuit is stored in the Start Correction Memory. The Start Correction Memory delivers a DC voltage to the Ratemeter. This DC voltage provides Ratemeter lead time and assists in correcting any error in the timing of the Ratemeter output.

### Random Operation

At a programmed time before the arrival of the trigger event, the Ratemeter produces a start command. The start command starts the Slewing Ramp. The Slewing Ramp and the Slow Ramp Inverter outputs are compared in the Slew-

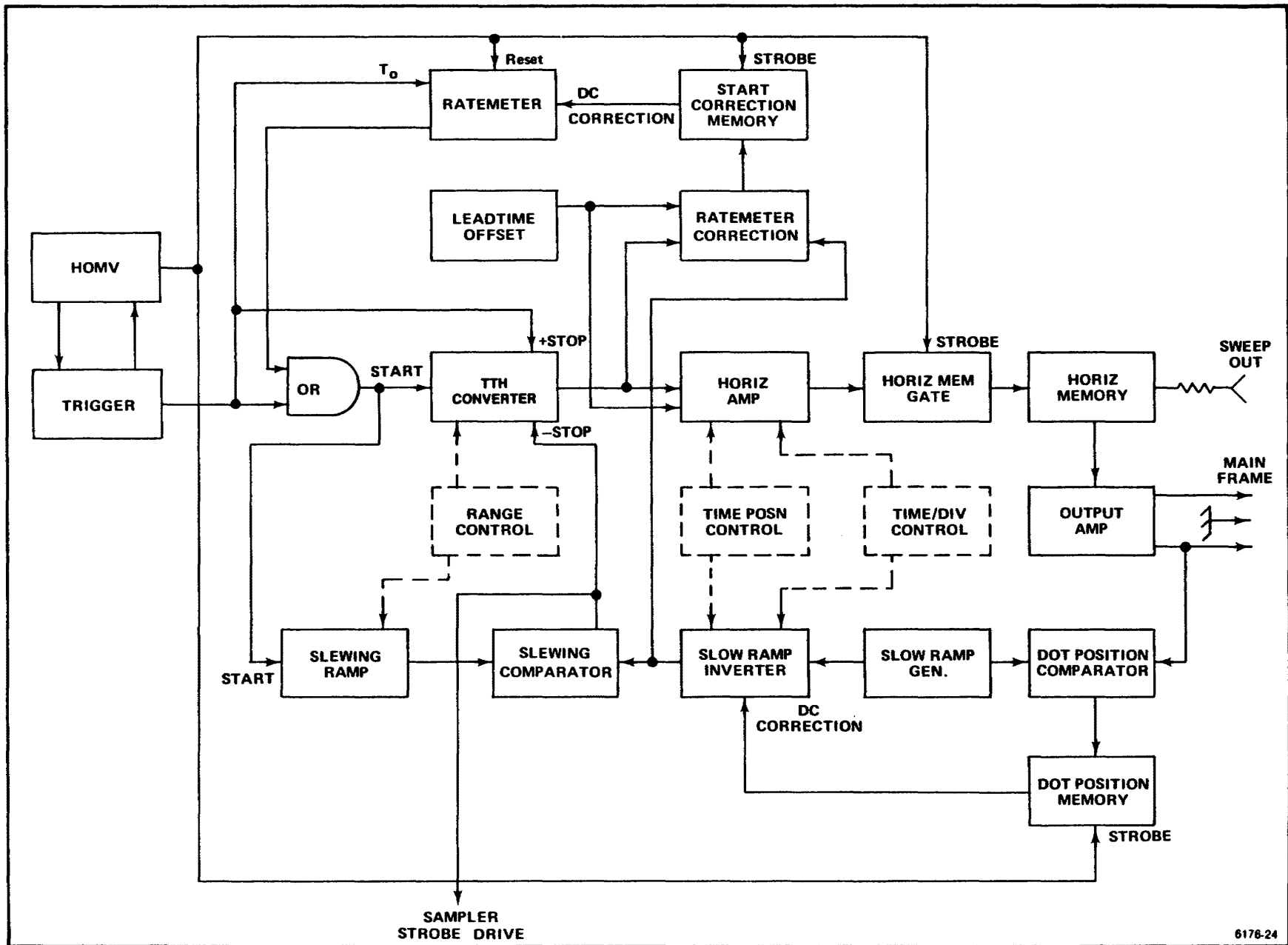

Figure 3-14. Random mode block diagram.

6178-24

ing Comparator, which will deliver an output (strobe pulse) when the two ramps reach the same level. Although the TTH Converter receives a start command from the Ratemeter at the same time as the Slewing Ramp, the TTH Converter does not initially make any output excursion. The reason for no initial TTH Converter output is that during Random operation the start command results in both a (+) input and an equal (-) input being applied at the same time to the TTH Converter input. If the trigger arrives before the strobe, a (+) stop command occurs and the TTH ramp runs negative until a strobe drive pulse and (-) stop command come from the Slewing Comparator. If the trigger and strobe events both happen simultaneously, the TTH Converter produces no change in output voltage. If the strobe occurs before the trigger, then the TTH ramp runs positive.

The start input to the TTH Converter and Slewing blocks of Figure 3-14 shows two inputs operating through an OR circuit. In normal Random operation, the Ratemeter produces a start drive pulse that precedes the trigger pulse. The incoming trigger pulse then has no more effect on the already started TTH Converter and Slewing Ramp circuits. In the event that the Ratemeter guesses much too late, or the period of an individual trigger is much shorter than the average period, then the trigger circuit will start the TTH Converter and Slewing Ramp circuits, the same as in sequential.

Correction of the timing of the Ratemeter start commands results primarily from the use of ( $T_0$ ) and HOMV (Reset) information fed to the Ratemeter. Because this correction is not adequate to make a start decision with the needed accuracy, the Start Correction Memory and DC correction circuits are added.

In the normal course of creating a CRT display, the strobe pulses are made to occur in a slewed manner over a window of time related to the trigger pulse. As the strobes slew across the time window, the TTH Converter produces different output levels corresponding to the different points in time.

The comparator (in the Ratemeter Correction block of Figure 3-14) checks the output level of the TTH Converter after it has been told to stop by both stop inputs. It compares this level plus a DC offset against the level of the Slow Ramp Inverter output. The comparator operating on the output of the TTH Converter uses the slewing programming as a reference base; if the start commands are operating at the correct time with respect to the trigger, the comparator reads the same voltage at the TTH Converter output as at the Slow Ramp Inverter (without leadtime offset). If the Slow Ramp Inverter has a -1 volt output, the TTH Converter must have a -1 volt output. To obtain the earliest

strobe possible after a start pulse has been received, the Slow Ramp Inverter output is set as close to zero as possible.

The DC offset provides the lead time correction needed to get the  $T_0$  point (0 volts output from the TTH Converter) shifted to the center of the screen with CW rotation of the Time Position controls. In order for this strobe to occur 1/2 a TPR (time position range) ahead of the trigger, the start command must occur 1/2 a TPR ahead of the trigger. The TTH Converter must be producing a voltage of +2.5 volts for the start (and the strobe) to be at this point ahead of the trigger. It is therefore necessary to add an offset voltage of 2.5 volts to balance out the difference in the comparator between the TTH Converter and Slow Ramp Inverter outputs. To keep the Dot Position Servo content, it is also necessary to insert an offset into the input of the Horizontal Amplifier to make it appear that the TTH Converter is putting out 0 volts instead of +2.5 volts. If the TTH Converter output level agrees with the Slow Ramp Inverter output, then the start command was correctly timed and no shift in DC correction is needed. If the level is offset (+), the start was too early. Once the circuit decides that the correct starting time has been reached, the DC correction stops moving. The Dot Position servo then balances its comparator so that the dot ends up in the correct position on the screen.

### Waveform Relationships During Random Sampling

Ideal waveform relationships during Random Sampling are shown in Figure 3-15. The Triggering Level is set at the level indicated by the dotted line on the input signal waveform. Trigger recognition  $T_0$  is occurring at 0  $\mu$ s, 25  $\mu$ s, 50  $\mu$ s, and so forth. Control settings are:

TIME POS RNG	5 $\mu$ s
SWEEP RANGE	.5 $\mu$ s/div to .1 ns/div
TIME/DIV	.5 $\mu$ s/div
TIME POSITION	fully ccw

Trigger repetition rate is constant and the Ratemeter is starting the Slewing Ramp 1/2 TPR (time position range) or 2.5  $\mu$ s before trigger recognition.

The waveform shown as the Ratemeter Input in Figure 3-15 is at its higher level during the same interval of time that the Trigger Output TD is at its higher level. When the Trigger Output TD goes to its high level at time  $T_0$ , a positive-going

pulse is fed to the  $T_0$  Gate of the Ratemeter. When the Trigger Output TD switches back to its low level, the negative-going portion of the Ratemeter Input waveform causes reset of the Ratemeter. By effectively measuring the time

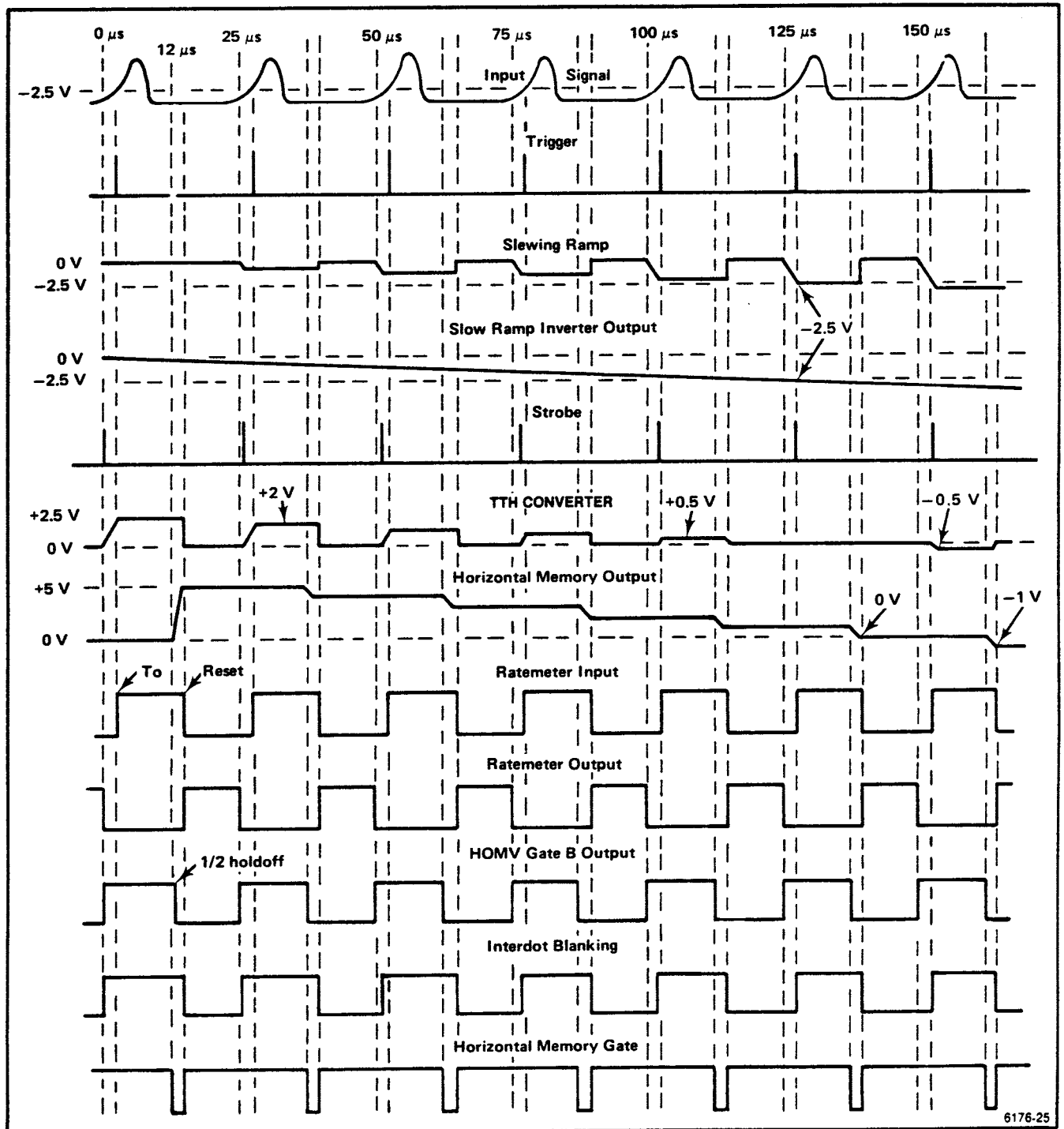

Figure 3-15. Ideal waveform relationships during Random equivalent-time sampling.

## Theory of Operation—7T11A

interval between reset and the following  $T_0$ , the Ratemeter is able to predict when the next trigger will occur. A change in trigger repetition rate results in the Ratemeter changing the timing of its output pulse to ensure starting of the Slewing Ramp  $1/2$  TPR before trigger recognition. The Ratemeter Comparator and Correction Memory also assist in maintaining the relationship between Ratemeter Output and  $T_0$ .

In Figure 3-15 the part of the vertical signal sampled by each strobe pulse is located vertically directly above each strobe pulse. The seven strobe pulses shown give a display of seven dots located one division apart horizontally (see Figure 3-16). The sixth strobe pulse occurs at the same time as the trigger (at  $125 \mu\text{s}$ ) and this sample is displayed 5 divisions from the left graticule edge. The triggering point is therefore displayed at the graticule center.

Using a slower SWEEP RANGE will provide more lead time ( $1/2$  of time position range) and permit seeing further ahead of the trigger. The TIME/DIV control will still permit selecting the same or other sweep rates. Lack of space on Figure 3-15 prevents showing the four additional strobe pulses required to fill the ten divisions display area.

The low dot density in Figure 3-16 is a result of the unrealistic slope of the Slow Ramp Inverter Output waveform shown. The actual slope is determined by the SCAN control and is much more gradual than illustrated.

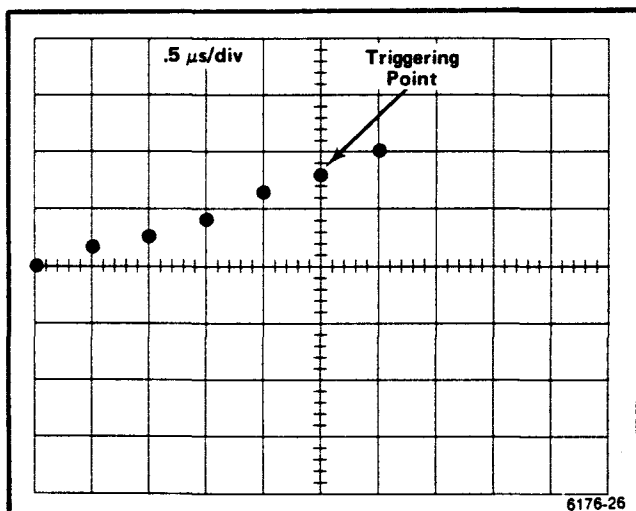

Figure 3-16. Display of samples taken in Figure 3-15.

The input to the Horizontal Amplifier, in the example shown in Figure 3-15, is identical to the TTH Converter Output except for being offset  $-2.5$  volts from that for the TTH Converter.

When the fastest SWEEP RANGE setting is selected (5 ns/div to 10 ps/div) an additional 50 ns of lead time is automatically switched in. Adding this 50 ns to the  $1/2$  TPR (time positioning range is 50 ns at the fastest SWEEP RANGE setting) gives a total lead time of about 75 ns. With a lead time of  $1 \frac{1}{2}$  TPR (75 ns) the TTH Converter is 7.5 volts more positive than the Horizontal Amplifier input. Although it may appear that the vertical input is being sampled 75 ns before  $T_0$ , such is not the case. If, for example, 50 ns is required for the strobe pulse to travel to the sampling bridge, the first sample displayed is actually taken only 25 ns before  $T_0$ .

## DETAILED CIRCUIT DESCRIPTION

### Introduction

The following description of 7T11A circuits begins with a discussion of the instrument's relationship with Sampling Units used in the oscilloscope's vertical compartments. Next, each circuit is described in detail in subsections having the same titles as related diagrams in Section 8 of this manual. These diagrams, as well as figures referred to in this section, will help in understanding the relationship between the various circuits.

### Relationships Between the 7T11A and Vertical Unit

Figure 3-17 shows the relationship between circuits in the 7T11A Sampling Sweep Unit and a Sampling Unit located in the adjacent vertical compartment of a 7000-Series oscilloscope. Designations of RT are used in Figure 3-17 to indicate switch positions during Real-Time operation. ET indicates switch positions during Equivalent-Time operation. Switching represented is actually done by transistors and diodes. The actual switching method used is discussed later in this section. The dotted lines in the vertical unit (labeled Strobe, Sampling Drive, and Oscillator Control) are in use only during Equivalent-time operation.

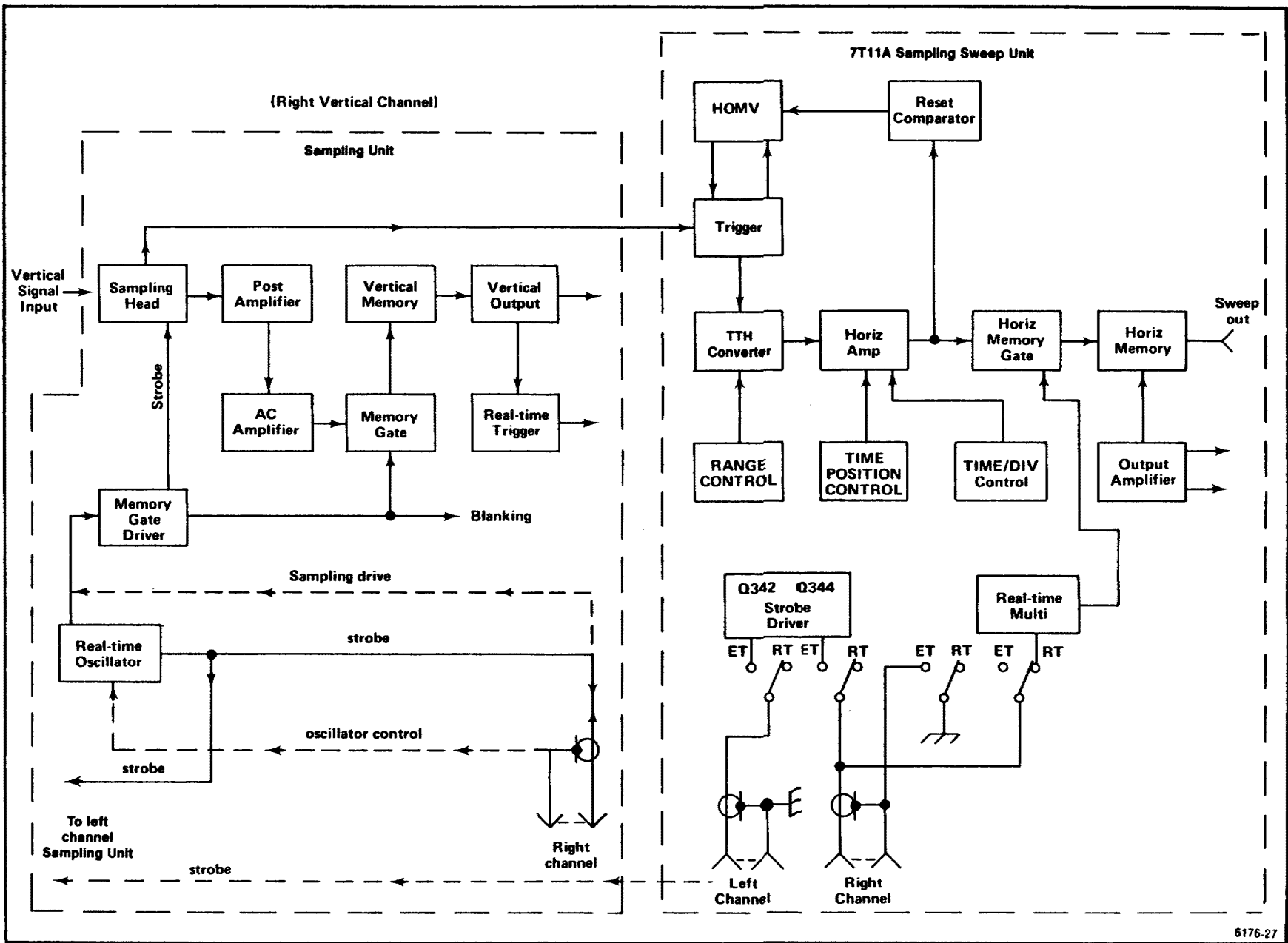

Figure 3-17. Block diagram showing interconnections between 7T11A and vertical plug-in during real-time operation.

## Theory of Operation—7T11A

In Figure 3-17, switching is shown set to the RT (real-time) position. The 50 kHz Real-Time Oscillator in the vertical unit is providing strobe pulses to the Memory Gate Driver in the vertical unit and to the Real-Time Multivibrator in the 7T11A. The strobe pulse to the Real-Time Multivibrator is supplied by the adjacent Sampling Unit Plug-in through the center conductor of a coaxial cable. Interconnection between units is via pin 14 of J641 (the connector mounted along the lower left side of the 7T11A).

With the switches in Figure 3-17 set to the ET (Equivalent-Time) position, the Real-Time Oscillator in the vertical unit is disabled and the Strobe Driver in the 7T11A supplies strobe pulses to the Memory Gate Driver of the vertical unit. During equivalent-time sampling (either Sequential or Random) the 7T11A determines when the signal applied to the vertical unit is sampled. During equivalent-time operation, the Real-Time Oscillator is disabled by effectively grounding the shield of the coaxial cable between the right-hand vertical plug-in and the 7T11A. The Real-Time Oscillator is disabled when the line labeled "Oscillator Control" is grounded.

The block in the Sampling Unit (see Figure 3-17), labeled Real-Time Trigger, serves no purpose when using a Sampling Sweep Unit such as the 7T11A. The Real-Time Trigger circuit is for use with conventional time base units. See the Sampling Unit instruction manual for further information about this circuit.



### 1 TRIGGER INPUT

A schematic diagram of the Trigger Input circuit is given on Diagram 1, in Section 8, Diagrams and Circuit Board Illustrations. The schematic is divided by grey shaded lines separating the circuitry into major stages. These stages aid in locating components mentioned here. Sub-headings in the following discussion use these stage names to further identify portions of the circuitry on Diagram 1.

#### General

Figure 3-18 is a block diagram of the complete trigger circuit. Four modes of triggering are available: Internal triggering from the signal applied to the sampling head of either vertical plug-in, or one of three modes of external triggering. All triggering signals are carried by 50  $\Omega$  stripline or coaxial cable. Triggering signals do not go through front-panel switches of the plug-in or the oscilloscope. Switching between different triggering modes is done by coaxially mounted reed relays controlled from the 7T11A front panel switches.

Triggering signals, except when the HF SYNC mode is selected, pass through the Trigger Slope Amplifier to the Schmitt Trigger circuit. The output of the Schmitt Trigger is fed to the Arming and Output tunnel diodes. Output Tunnel Diode CR152 (Diagram 2), if ready to recognize a trigger, provides a fast trigger signal to start the TTH ramp and the HOMV cycle.

The 1 Meg Amplifier shown in Figure 3-18 is used only if the EXT 1M triggering mode is selected. The X10 Amplifier is available on all triggering modes except HF SYNC.

#### Internal Triggering

When internal triggering (INT) is selected, a portion of the input signal from either of the Sampling Unit plug-ins can be fed to the 7T11A. This signal is carried between the adjacent vertical plug-in and the 7T11A through contact 2 or 8 of J641 (lower left side of the 7T11A).

Within the 7T11A the triggering signal passes through the closed contact of internal (INT) reed relay K32 (see Figure 3-18) to the Trigger Slope Amplifier (Q62 and Q72). The Trigger Slope Amplifier provides the proper polarity (positive-going) signal to the Schmitt Trigger circuit when triggering from either the positive-going or negative-going portion of the vertical input signal. When the Schmitt Trigger circuit fires, a fast-rise pulse is coupled to Arming and Output tunnel diodes CR142 and CR152.

With the INT pushbutton on the 7T11A pushed, the vertical unit (left or right) that supplies the triggering signal is selected by pressing its INT TRIG pushbutton. Figure 3-19 is a simplified diagram of the circuits used to determine which vertical unit supplies the triggering signal. The figure shows a Sampling Unit in both the right and left-hand vertical plug-in compartments of the oscilloscope. The Sampling Unit in the right-hand plug-in compartment is supplying the internal triggering signal to the 7T11A. Which sampling unit supplies the 7T11A trigger depends upon the state of the multivibrator in the Multivibrator and Trigger Logic Block of Figure 3-19. One-half of this multivibrator is in the left channel Sampling Unit and the other half is in the right channel Sampling Unit. Although this simplified circuit represents the trigger logic circuit using a switch and resistor, the actual circuit utilizes transistors, diodes, and resistors.

In Figure 3-19, triggering from the right channel has been selected and a portion of the input signal to this channel is applied, through Q38 and the closed contacts of INT reed relay K32, to the Trigger Slope Amplifier (Q62 and Q72). Q62 and Q72 are shown in block diagram form in Figure 3-19.



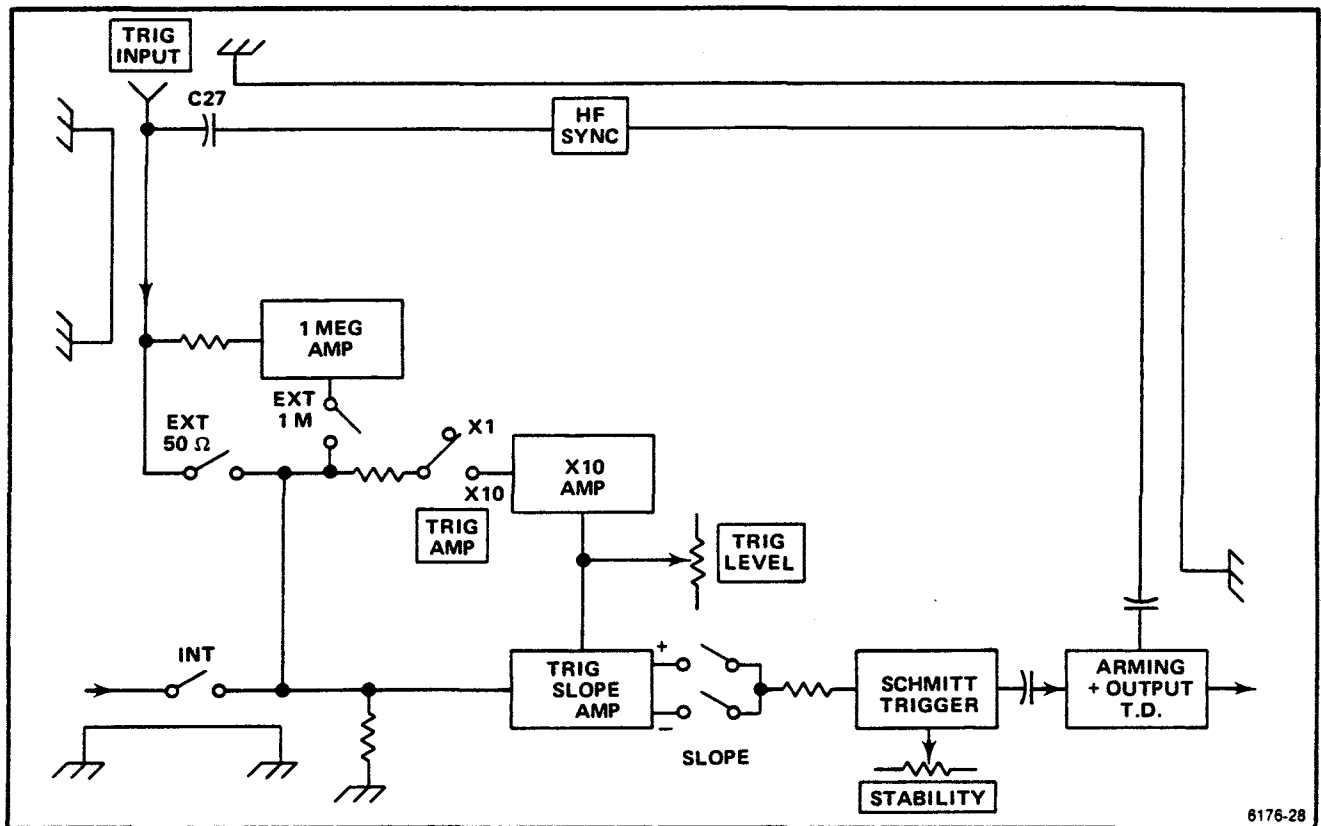

Figure 3-18. Block diagram of the 7T11A trigger circuit.

In Figure 3-19 the low resistance shunting the left channel trigger pickoff and the input of Q36 reduces the level of this trigger signal below the level required to forward bias Q36. Pressing the INT trigger pushbutton on the left channel vertical plug-in causes the multivibrator to change state. The shunting resistance is removed from Q36 input and Q38 input is now shunted by a low value of resistance. The trigger signal picked off the left channel sampling head is now applied to the Trigger Slope Amplifier through Q36.

With the 7T11A INT trigger pushbutton pushed in, the coil of reed relay K32 is connected to +5 volts. Energizing this relay completes the circuit between the sampling head and the Trigger Slope Amplifier. The other set of contacts on the 7T11A INT trigger switch provide a ground to the multivibrator and trigger logic circuits in both Sampling Units. Without this ground the INT trigger pushbuttons on the vertical units will not light, due to reverse biasing of their current sources. This reverse bias causes shunting of the trigger pickoffs of both sampling heads, preventing passage of trigger signals through either Q36 or Q38.

#### External (EXT 50 Ω) Triggering

When the 7T11A External 50 Ω input pushbutton is pushed in, trigger signals connected to the TRIG INPUT connector pass through contacts of EXT 50 Ω reed relay K31 to the Trigger Slope Amplifier. Refer to Figure 3-18. Selecting EXT 50 Ω provides a more direct and higher speed path than the INT or EXT (1 M) modes.

#### External (EXT 1 M Ω) Triggering

When the EXT 1 MΩ pushbutton is pushed in, the 1 MEG AMP is inserted between the TRIG INPUT connector and the input of the Trigger Slope Amplifier. The 1 Meg Amplifier is a X1 gain, 1 megohm input FET amplifier. R42 provides the 1 megohm input impedance. Series limiting resistor R43 provides overload protection to the input of the amplifier for positive voltages. Diode CR43 provides overload protection against excessive negative input voltages. 1 M ZERO ad-

6176-28

justment R45 is used to set the amplifier output to 0 VDC when no trigger signal is applied. Resistor R51 and C51 provide power supply decoupling while diode CR51 protects Q50 emitter-base junction against excessive reverse bias.

The trigger signal is applied to the gate of Q44A. This signal appears at the drain of Q44 and is coupled to Q44B through Q50. The signal appearing at the gate of Q44B is practically equal in amplitude to, and is the same polarity as, the signal applied to the gate of Q44A. Negative feedback appearing across the common source resistor R47 limits gain of the 1 MEG AMP to X1.

### HF SYNC

When HF SYNC is selected, the Schmitt trigger circuit is disabled by applying a large forward bias to the base of Q128 (Diagram 2). A simplified diagram of the HF SYNC circuit is shown in Figure 3-20. Important parts of the HF SYNC circuit are integrated circuit U20, 200 MHz tunnel diode oscillator CR28, and 10 MHz tunnel diode CR29.

Integrated circuit U20 (pin 4) supplies +7.15 volts as a stable source of voltage for the front-panel STABILITY control and HF Sync Adjustment R10. The integrated circuit also delivers a stable voltage of approximately +3 volts from pin 6 for use by tunnel diode oscillator CR28. The voltage at pin 6 of the integrated circuit can be changed approximately  $\pm 10\%$  by rotating the STABILITY control.

The 200 MHz oscillator (CR28) is synchronized to a submultiple of the incoming high-frequency trigger signals. The high-frequency sine-wave or pulse trigger signal, applied to the TRIG INPUT connector, is coupled to the 200 MHz oscillator through a coupling arrangement built into the trigger circuit board and through C27. Oscillator inductor L23 is the lead of tunnel diode CR28. Trigger signals, within a frequency range of approximately 1 to 12 GHz, are counted down to about 200 MHz by CR28. The free-run frequency of CR28 is adjustable with R10. The 7T11A STABILITY control permits the 200 MHz oscillator frequency to be varied about the value set by R10. The STABILITY control can be used as a coarse sync control during HF SYNC operation.

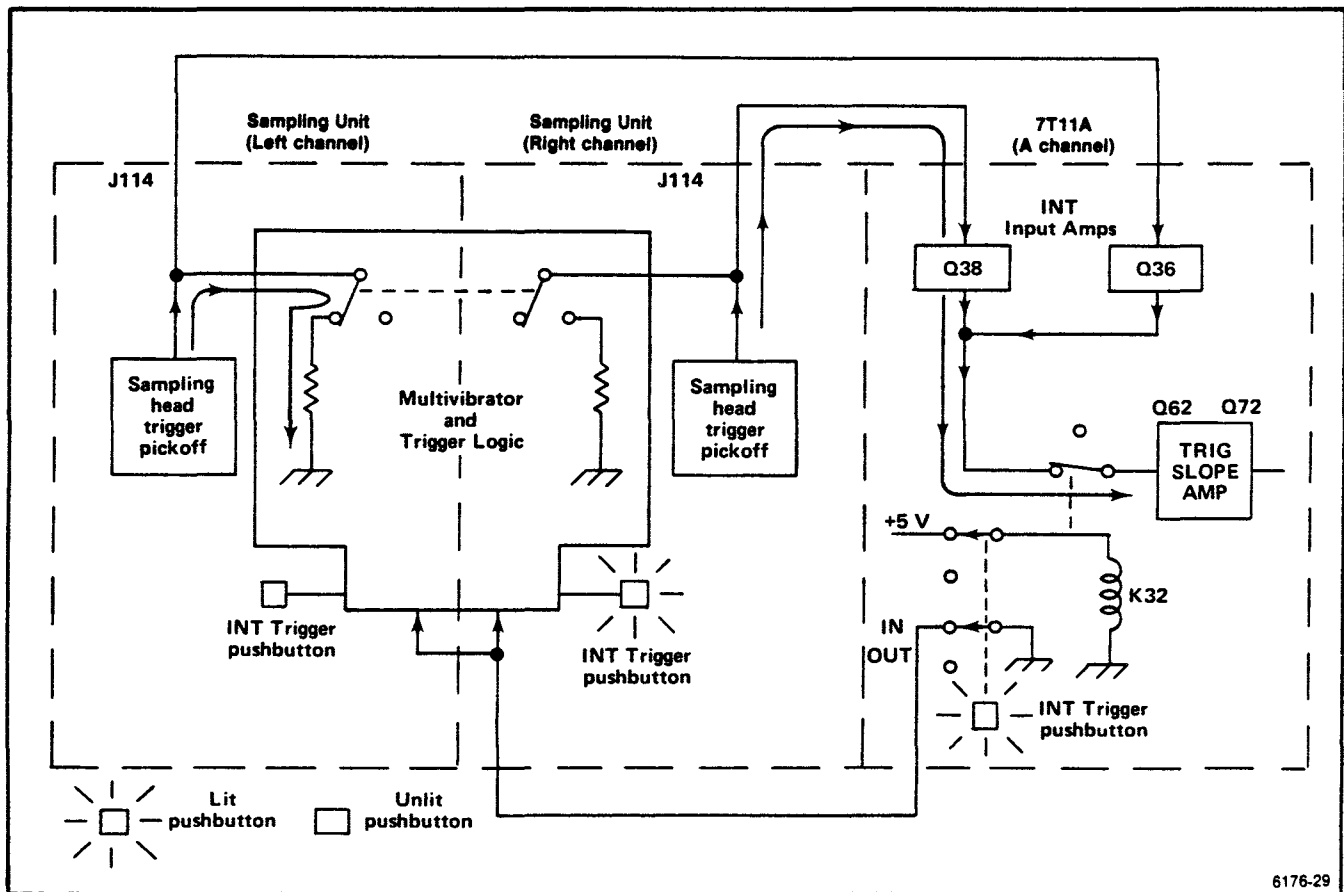

6176-29

Figure 3-19. Simplified 7T11A Trigger Selector circuit showing use of right channel Sampling Unit as source of internal trigger signal.

Rotating the TRIG LEVEL control causes a slight change in the bias of the 200 MHz tunnel diode oscillator. During HF SYNC operation the TRIG LEVEL control functions as a fine sync control.

The output of CR28 is counted down by a factor of about 20 to 1 by 10 MHz tunnel diode oscillator CR29. Sync Countdown adjustment R30 is used to set the bias and fre-

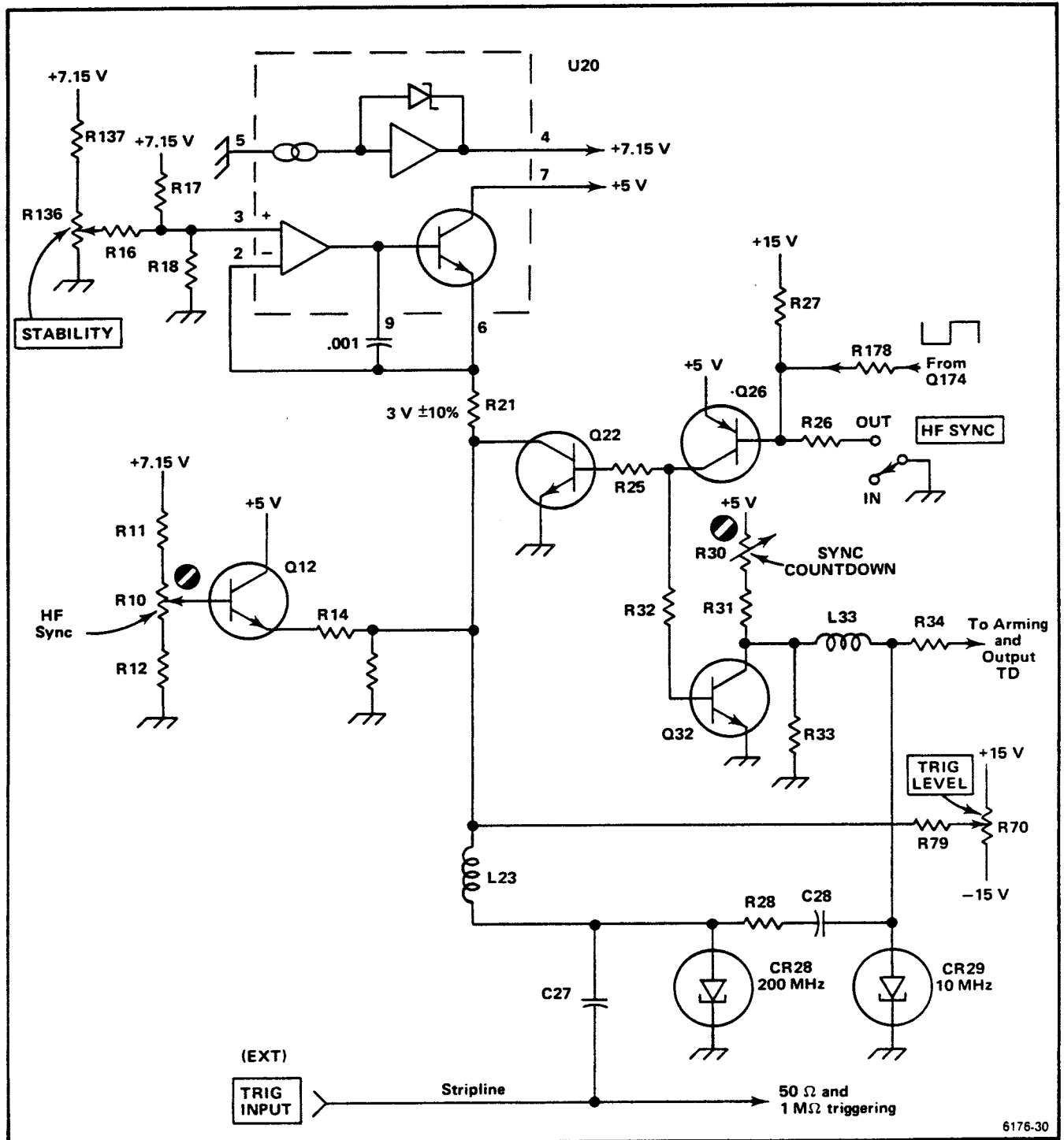

Figure 3-20. Simplified diagram of HF SYNC circuit.

quency of the 10 MHz tunnel diode oscillator. The approximate 10 MHz output of CR29 is fed through R34 to the Arming and Output tunnel diodes (Diagram 2).

When the 7T11A HF SYNC pushbutton is in the out position both tunnel diode oscillators are disabled. The base of transistor Q26 is grounded through R26 causing Q26 to turn ON. Conduction of Q26 causes both Q22 and Q32 to turn ON. Conduction of Q22 disables the 200 MHz oscillator and Q32 disables the 10 MHz oscillator.

Pushing in the HF SYNC pushbutton removes the ground, applied through R26, from the base of Q26. With the HF SYNC selected the tunnel diode oscillators free-run except when a negative pulse is applied to the base of Q26 through R178 (Diagram 2). This negative pulse is applied when the Arming and Output tunnel diodes (CR142 and CR152 of Figure 3-21) are at their high level.

Output triggers from the Sync Oscillator are coupled directly to the Arming and Output tunnel diodes, CR142 and CR152 respectively. See "Arming and Output Tunnel Diodes" in the discussion for Diagram 2, TRIGGER & HOLDOFF, for more information.

### Trigger Slope Amplifier, SLOPE (-) or (+)

Diagram 1, TRIGGER INPUT, in Section 8 shows the Slope Amplifier connections with negative slope (-) selected. Q62 and Q72 are connected as a differential amplifier. With the TRIG LEVEL control set to mid-position, and no input trigger, current through each transistor is about 5 mA. Q72 current is delivered by the +5 volt supply through CR73, while Q62 current is supplied through R69. Current through R69 must be reduced below 5 mA to cause triggering of the Schmitt Trigger circuit. With (-) slope selected, this will occur when the base of Q62 is driven below the level on the base of Q72. With (+) slope selected, triggering will occur when the base of Q62 is driven above the level at the base of Q72. The level at the base of Q72 is determined by the setting of the TRIG LEVEL control. Triggering on either the positive-going or negative-going portion of the trigger signal can be selected using SLOPE switch S70.

### Trigger Amplifier (TRIG AMP X1, X10)

The trigger path is connected to one input of the Slope Amplifier at all times. When the X10 pushbutton is pushed in, this same trigger path is also connected to the input of the X10 Amplifier. Q82 and Q92 form a high speed inverting amplifier. The amplified and inverted output of this amplifier

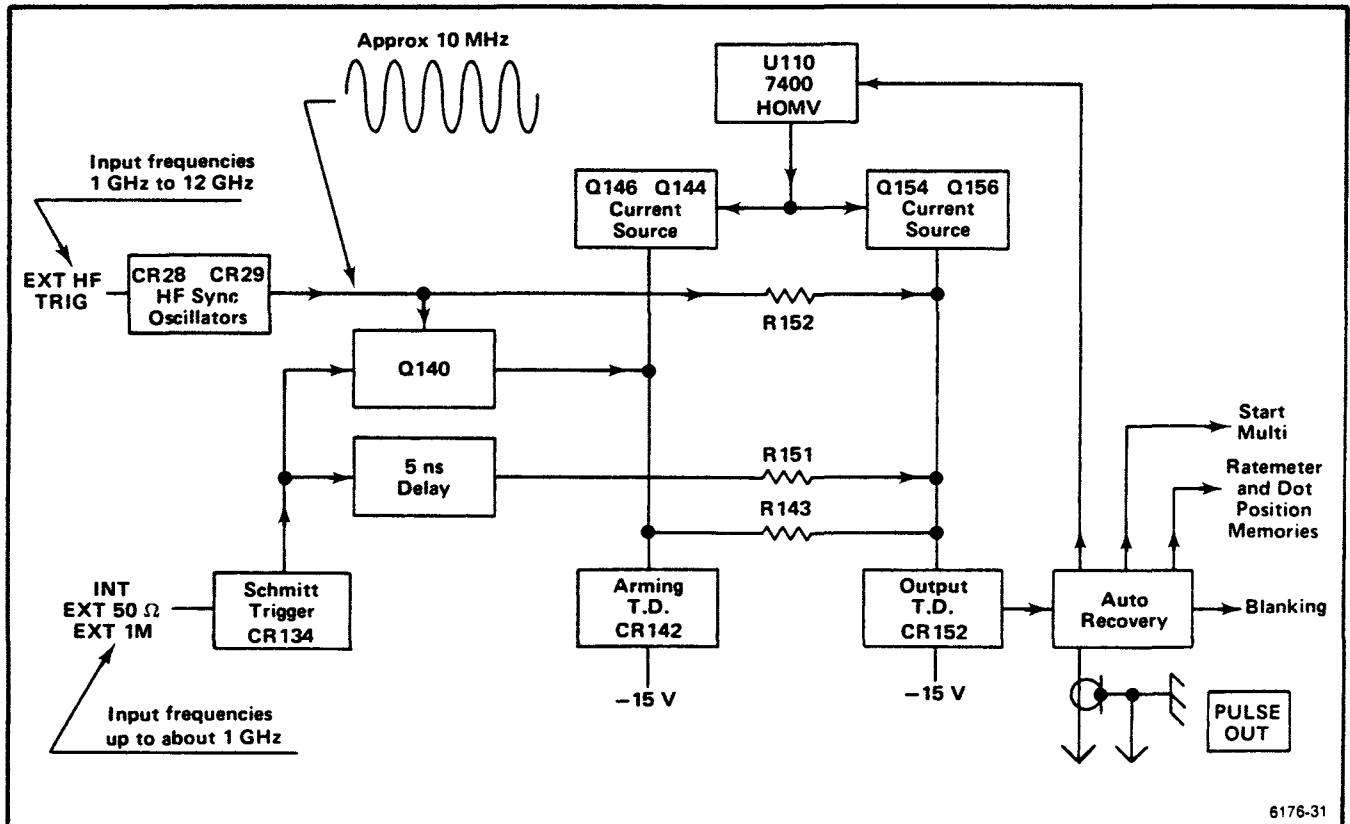

Figure 3-21. Relationship of the Output Tunnel Diode to other 7T11A circuits.

is fed to the other input of the Slope Amplifier, giving an effective boost to the gain, especially for trigger risetimes of greater than a few nanoseconds.

The input trigger is applied to the base of Q82A. The signal appearing across the emitter resistor R88 serves as the input signal to Q82B. The in-phase signal developed across R87 is fed to the base of Q92. The inverted output signal appears across R96 and is coupled through C93 to the base of Q72. The amplified trigger signal appearing at the emitter of Q72 aids the unamplified signal at the base of Q62 and results in a X10 amplification of the trigger signal.

X10 Zero adjustment R80 is used to set the voltage at the output of the X10 Amplifier to 0 volts. Diodes CR91 and CR92 protect transistor Q92 against excessive reverse bias. Power supply decoupling is provided by R86 and C86. Decoupling filters are also used in the +5 and -15 volt supply lines.

## 2

### TRIGGER & HOLDOFF

A schematic diagram of the Trigger & Holdoff circuit is given on Diagram 2, in Section 8, Diagrams and Circuit Board Illustrations. The schematic is divided by grey shaded lines separating the circuitry into major stages. These stages aid in locating components mentioned here. Sub-headings in the following discussion use these stage names to further identify portions of the circuitry on Diagram 2.

#### Schmitt Trigger

The Schmitt trigger circuit used in the 7T11A provides a hysteresis band that can be made very narrow (around 1 millivolt) while retaining the use of a very fast, non-stabilizable tunnel diode. The tunnel diode is connected into a positive feedback circuit that does two things: It amplifies, by positive feedback, an input trigger signal; and once the tunnel diode has changed state in response to step trigger input, the circuit reduces current in the tunnel diode so that it will revert to the low state when the trigger step is removed. This circuit is disabled when the HF SYNC push-button is pushed in.

With tunnel diode CR134 (see Figure 3-22) armed and sensitive to small trigger input signals, current through the tunnel diode is just slightly below the value required for firing. The current through Q122 can be adjusted using Trig Level Zero adjustment R120. Part of Q122 current flows

through Q128 and the remainder through the series combination of the tunnel diode and Q138. An additional current is supplied to the series combination of the tunnel diode and Q138 through resistor R132.

Adjusting Trig Level Zero adjustment R120 permits the tunnel diode current to be set to just below the firing value (see point 1 on Figure 3-23). A small positive-going trigger signal at the emitter of Q122 causes an increase of current. This increase in Q122 current flows through the tunnel diode and Q138. Even if this initial increase does not cause tunnel diode current to exceed the value designated as  $I_p$ , rapid firing of the tunnel diode may still occur due to amplification in the circuit. Any increase in tunnel diode current produces a change in voltage at the collector of Q138. A part of this change in voltage, as determined by the settings of Stab Zero adjustment R135 and the front-panel STABILITY control, appears at the emitter of Q128 as a decrease in forward bias. This results in a larger percentage of Q122 current passing through tunnel diode CR134 and transistor Q138. If the initial increase in tunnel diode current plus the increase due to amplification result in tunnel diode current exceeding  $I_p$ , the tunnel will switch to point 2 on Figure 3-23. Switching of the tunnel diode results in a loss of tunnel diode current because of the DC load supplied by R132. This loss of current is amplified by the circuit. The decrease in tunnel diode current causes an effect opposite to that produced by an increase in tunnel diode current. The forward bias of Q128 increases and a larger portion of Q122 current flows through Q128 causing tunnel diode current to move from point 2 on Figure 3-23 to point 3. With the tunnel diode current set to a value just greater than  $I_p$ , removal of the small triggering current causes the tunnel diode to switch back to the low voltage state shown as point 4. With the tunnel diode in the low voltage state, current is again supplied through R132 and tunnel diode current is again returned to the value indicated by point 1. The output of the Schmitt Trigger circuit is fed to Arming and Output TD's CR142 and CR152.

The front-panel STABILITY control permits control of the sensitivity of the Schmitt trigger circuit. Gain of the amplifier is dependent upon the parallel resistance of Stab Zero adjustment R135 and the resistance of photosensitive resistor R136. Applying a more positive voltage from the STABILITY control to the base of Q136 increases light output. An increase in light output reduces the resistance of light sensitive resistor R136 and increases the gain of amplifier Q128 and Q138. The STABILITY control receives regulated voltage from integrated circuit regulator U20 (Diagram 1) through R137.

**Hold-Off Multivibrator (HOMV)**

The HOMV is responsible for supplying signals at the proper time to several different circuits. Outputs to five different circuits are shown along the right side of Figure 3-24.

The HOMV consists of four, two-input gates. The four sections are shown as U110A, B, C and D in Figure 3-24.

The four gates are divided into two sets. Each set is connected as a DC coupled multivibrator. The first set is formed using the gates designated A and B and having terminals, 1, 2, 3, 4, 5 and 6. These two gates form the HOMV. The second set, consisting of gates C and D is used for Horizontal Memory Gate drive pulse logic and Real-Time HOMV logic.

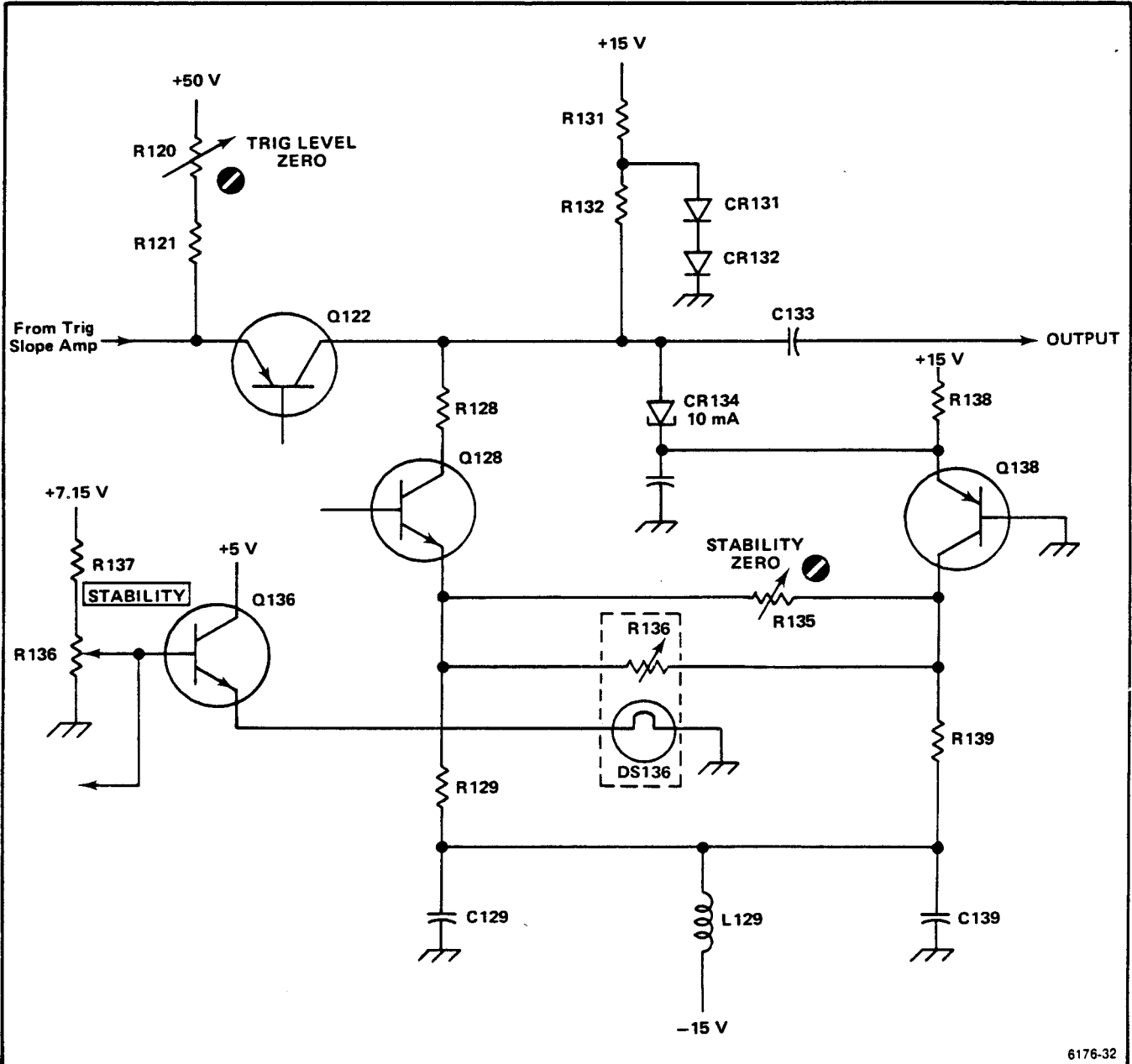

6176-32

Figure 3-22. Simplified schematic of the Schmitt Trigger circuit.

Each of the gates has the following characteristics: When both inputs are above +2 volts, the output is at 0 volts. Inputs to the gates will rise above +2 volts if the input circuit is opened. When one or the other input is pulled below 0.8 volts with a current of 1 mA, the output goes to +4 volts. Since both inputs of Gates B and D are connected together they function as inverters.

The quiescent state of the gate is as follows: The output of Gate A is 0 volts, B is +4 volts, C is +4 volts, and D is 0 volts.

Inputs 1 and 2 of Gate A are both above +2 volts due to the positive voltage at the junction of R174 and R176. The voltage at this junction reverse biases Q102 and forward biases Q104. With Q102 reverse biased, input 1 is open and will pull itself up to a positive voltage. Input 2 is positive due to current through Q104 and R105.

The 0 volt output at pin 3 of Gate A is applied to inputs 4 and 5 of Gate B and results in +4 volts at the output (pin 6) of Gate B. Conduction of diode CR105 holds pin 2 positive when current through Q104 ceases shortly after trigger recognition ( $T_0$ ).

The output of Gate C is also +4 volts. Pin 9 input of Gate C is above the +2 volt level if the equivalent-time mode is used and below the +0.8 volt level during real-time operation (note voltage at top of R103 in Figure 3-24). Gate

C output (pin 8) will be +4 volts however, when Gate A output is 0 volts, since pin 10 is kept below the +0.8 volt level by input current supplied through R108 and CR106. With Gate C output at +4 volts, the Gate D output (pin 11) is 0 volts.

The main difference in the action of the HOMV during real-time and equivalent-time operation is the manner and time at which sections C and D change state. During equivalent-time operation, pin 9 of the integrated circuit is held positive by voltage applied through R103 and CR103. All that is required to cause sections C and D to switch levels is to raise the voltage on pin 10 to about +2 volts. When Gate A output switches to +4 volts, diode CR106 is reverse biased, and pin 10 pulls itself positive at a rate determined by the RC of R108 and C106. When the voltage at pin 10 reaches approximately +2 volts, the output of Gate C switches to 0 volts and causes Gate D output to switch to +4 volts.

During real-time operation, raising pin 10 to a positive potential may not change the state of Gates C and D, because a positive potential must be present at both Gate C inputs (pins 9 and 10). The positive voltage applied through R103 and CR103, during equivalent-time operation, is not present during real-time operation. The positive voltage required at pin 9 is supplied by reset transistor Q554 (Diagram 6). This reset pulse occurs when the output ramp of the Horizontal Amplifier reaches approximately +5.2 volts.

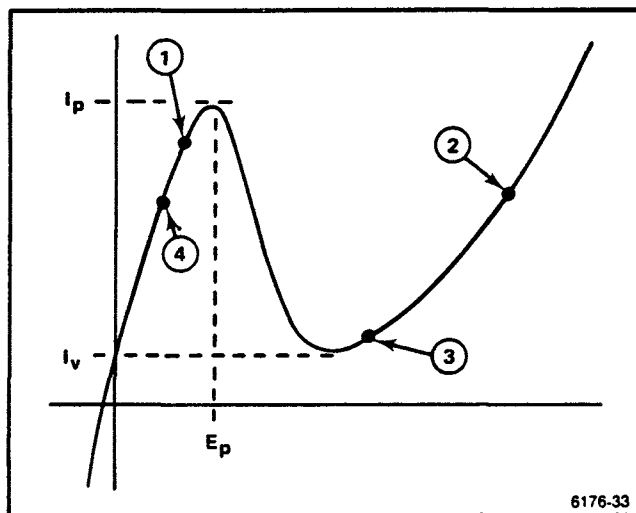

Figure 3-23. Operating characteristics of Schmitt Trigger circuit tunnel diode (CR134).

### Real-Time HOMV Switching

Use of Figure 3-25 and Figure 3-24 together with the block diagram in Figure 3-2 will aid in understanding the time relationships of inputs and outputs of the real-time circuits in the following discussion.

Assume that the TTH Converter has recovered from the previous sweep and Output TD CR152 is armed and ready to be triggered. The arrival of a suitable triggering signal switches the Output TD to its high state, at a time designated as  $T_0$  on Figure 3-25. This sends a negative-going pulse from Q162 to Q212 (Diagram 3). The Start Multivibrator then causes the TTH Converter circuit to start a negative ramp output. Q162 also cuts off Q164, driving Q174 into conduction. The conduction of Q174 produces a negative output at its collector and this output is utilized in three places during real-time operation. Figure 3-24 shows that this output is applied through R178 to the base of Q26 (Diagram 3) if HF Sync triggering is selected. This disables the HF Sync oscillator.

The signal at the collector of Q174 is also applied through Q194 to Q196. As explained earlier, none of the four types of blanking can produce blanking unless Q196 is turned on. Real-Time Retrace blanking is disabled at this time due to conduction of Q234 in the Start Multivibrator. Interdot blanking is not active at time  $T_0$  unless a strobe pulse happens to occur simultaneous with the switching of the trigger Output tunnel diode to its high state.

The negative signal output of Q174 at  $T_0$  drives Q184 into conduction. The positive pulse appearing at the collector of Q184 is delivered, by way of Q186, to the PULSE OUT connector on the 7T11A front panel. The negative pulse at the collector of Q174 occurs when Output tunnel diode CR152 switches to its high state (at time  $T_0$ ) and remains until CR152 is returned to its low state by an output from pin 11 of the HOMV.

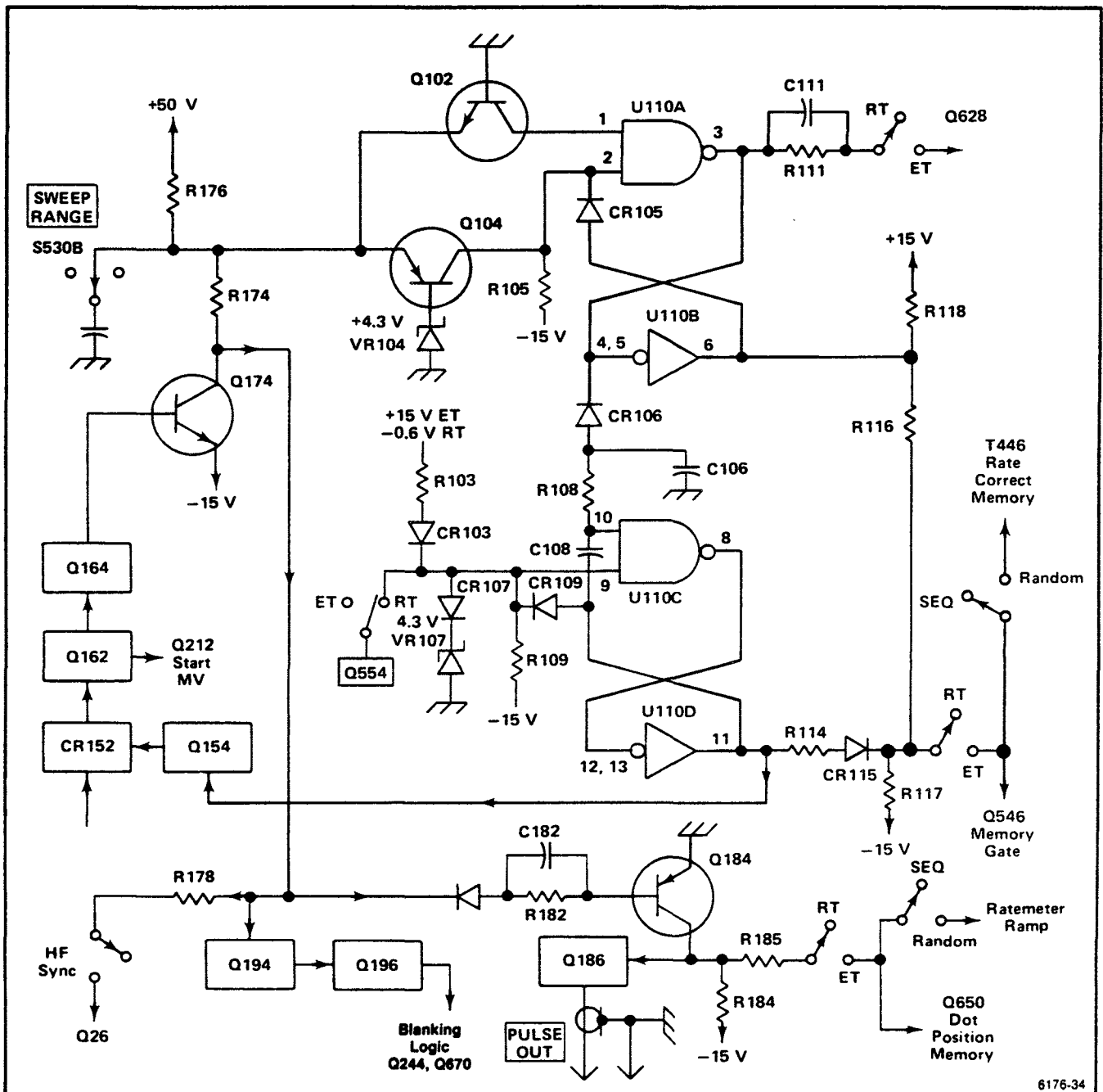

Figure 3-24. Outputs of the HOMV and associated circuits.



Another output occurs as a result of the conduction of Q174 at time  $T_0$ . The voltage at the junction of R174 and R176 drops from +4.9 volts toward -5.3 volts at a rate determined by a hold-off capacitor switched in by the range switch. When the hold-off capacitor voltage reaches -0.6 volts, Q102 turns on, causing gates A and B to change state. When gates A and B change state, current through R105 and CR105 holds the gates in this state after removal of the negative voltage applied through Q102. This change in state of gates A and B occurs at a time referred to as 1/2 hold-off interval. Figure 3-25 shows this occurring 1 ms after time  $T_0$ .

The switching of gates A and B at 1/2 hold-off interval causes the input current to pin 10 of gate C (through R108 and CR106) to stop due to reverse biasing of CR106. With input current stopped, pin 10 of gate C pulls itself positive at a rate determined by the RC at this input. When the voltage at pin 10 of gate C reaches approximately +1.5 volts, gate C switches provided its pin 9 input is also positive. As previously mentioned, pin 9 is kept positive at all times during equivalent-time operation, but during real-time operation pin 9 is driven positive by Q554 (Diagram 6) when the output of the Horizontal Amplifier reaches about +5.2 volts. During real-time operation, Q554 usually drives pin 9 of gate C positive after pin 10 reaches the required +1.5 volts. With both pin 9 and pin 10 positive, gate C output switches to 0 volts, driving gate D output to +4 volts.

If the TIME POSITION control is set fully CW so that the Horizontal Amplifier ramp starts at the same time as the TTH ramp, and if a fast real-time sweep rate is selected, pin 9 of gate C will be driven positive by Q554 before pin 10 reaches +1.5 volts. Gate C will therefore not switch until C108 charges to the required +1.5 volts. The output of the Horizontal Amplifier will continue above +5.2 volts until limited by the dynamic range of the amplifier. Since Overrun blanking permits a display of only the 0 to +5 volt portion of the Horizontal Amplifier output, no adverse effects result.

When gates C and D switch, a positive pulse is coupled to Q144 and Q154, the current sources for Arming TD CR142 and Output TD CR152 respectively. This causes both tunnel diodes to go to their low state. Q162 shuts off, causing the Start Multivibrator to shut off and end the TTH ramp and enable Real-Time Retrace blanking. Q164 starts conducting, causing Q174 to shut off. The positive pulse at the PULSE OUT connector now ends.

When Q174 shuts off, the junction of R174 and R176 attempts to go to +50 volts but is prevented from doing so by the hold-off capacitor. When the charge on this capacitor reaches approximately +4.9 volts, transistor Q104 conducts, returning Gates A, B, C and D of the HOMV to their

quiescent state. The Arming and Output tunnel diodes receive bias and the cycle is to repeat when another trigger is recognized.

### Equivalent-Time HOMV Switching

Figures 3-24 and 3-26 together with the block diagram in Figure 3-8 will aid in understanding time relationships of the equivalent-time circuits in the following discussion.

The right side of Figure 3-24 shows a total of five circuits receiving signals from switching of the HOMV during equivalent time sampling. The switching shown in Figure 3-24 is actually done using transistors. Figure 3-26 shows waveform relationships during sequential equivalent-time sampling. The same basic time relationships exist during Random sampling except for the influence of the Ratemeter circuits and lead time offset current on sweep related circuits. Comparison of Figure 3-15 with Figure 3-26 shows that the same basic time relationships hold between the HOMV, Trigger, and blanking circuits.

The output levels of the four gates, just prior to trigger recognition, is the same as listed for Real-Time HOMV operation. Output of Gate A is 0 volts, B is +4 volts, C is +4 volts, and gate D is 0 volts.

When the Output TD in the trigger circuit fires, Q174 conducts. Q184 also conducts, producing a pulse output drive and a drive pulse to the Ratemeter  $T_0$  memory level. Conduction of Q174 results in the voltage at the junction of R174 and R176 dropping from +4.9 volts toward -5.3 volts at a rate determined by the hold-off capacitor switched in by the SWEEP RANGE switch. When the capacitor voltage reaches -0.6 volts, Q102 turns on, causing A and B gates to change state. This is shown occurring 10  $\mu$ s after time  $T_0$  in Figure 3-26.

When Gate B goes from +4 volts to 0 volts, part of this change in voltage appears at the junction of R116 and R117. Figure 3-25 shows that this negative pulse is applied to the base of Q546 (Horizontal Memory Gate circuit, Diagram 6) as a conduction command during equivalent-time sampling.

The switching of Gate A output from 0 volts to +4 volts shuts off input current to pin 10 of Gate C due to reverse biasing of CR106. Within approximately 2  $\mu$ s the voltage at pin 10 of Gate C (see Figure 3-26) rises to the approximate

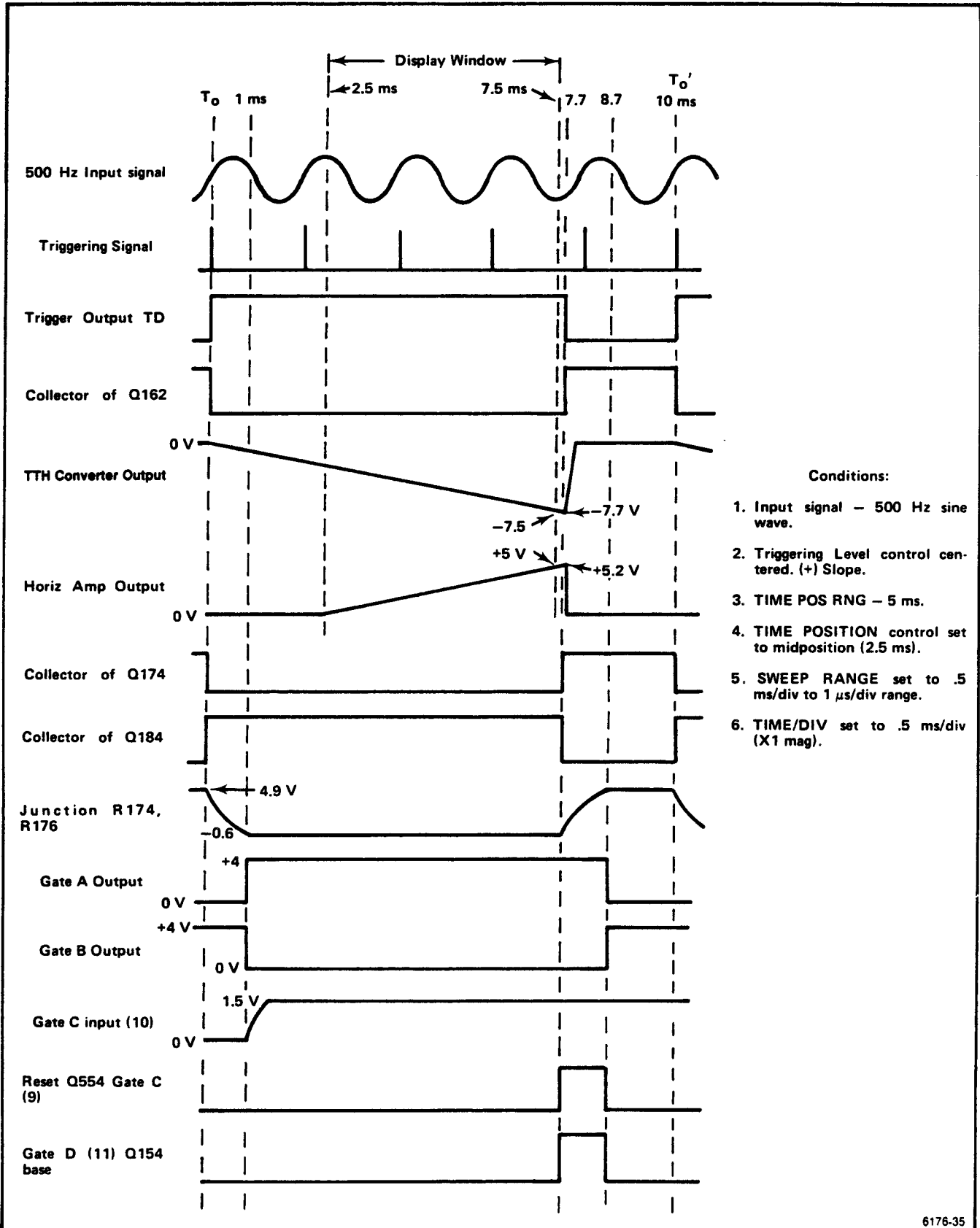

Figure 3-25. Trigger, Sweep, and HOMV waveform relationships during real-time sampling.

6176-35

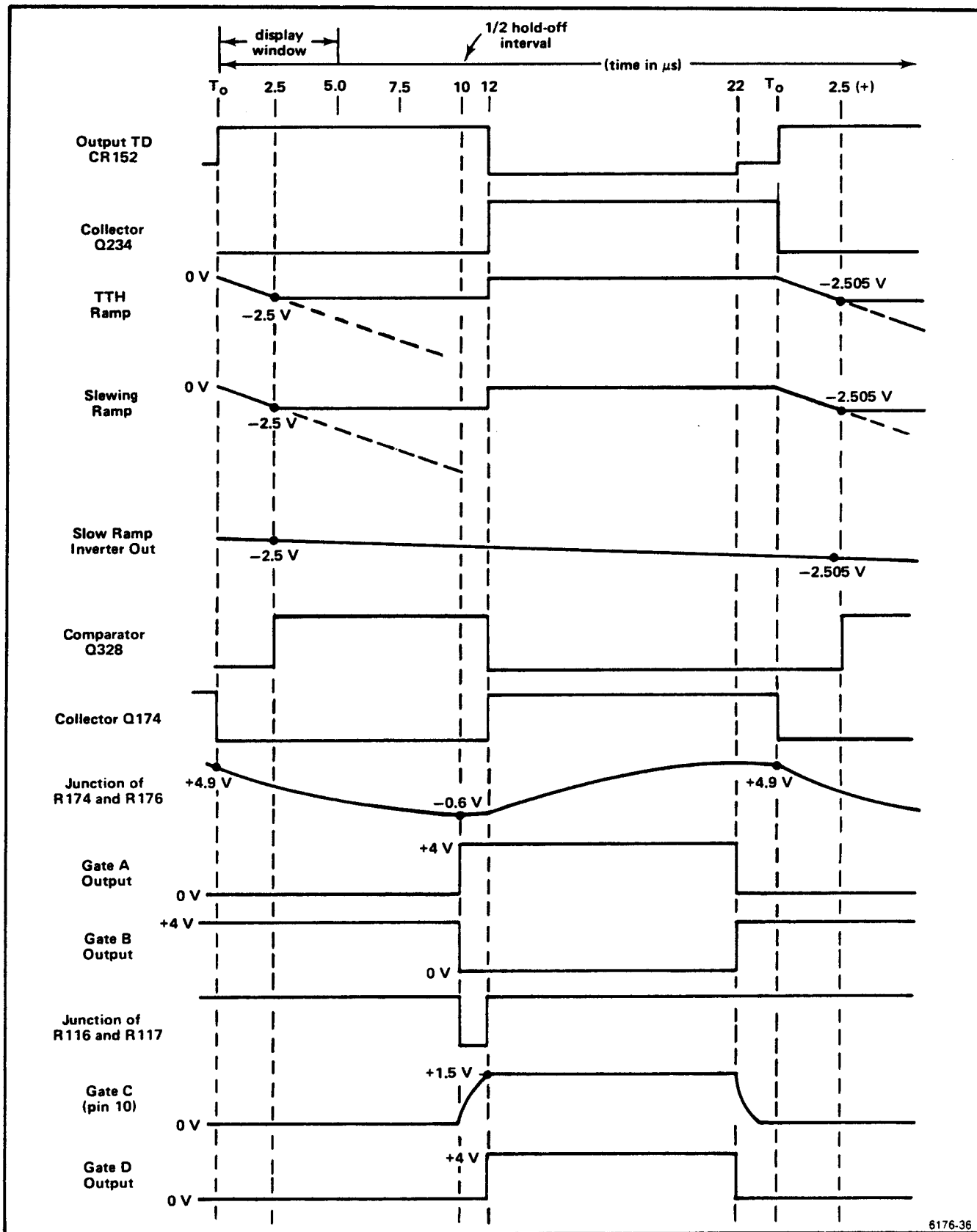

Figure 3-26. Typical waveform relationships during sequential equivalent-time sampling.

6176-36

## Theory of Operation—7T11A

+1.5 volts required to cause switching of Gates C and D. The requirement that both Gate inputs be positive to get a low output is met since pin 9 is also positive. Figure 3-24 shows that during equivalent-time operation a positive voltage is supplied to pin 9 through R106 and CR106.

Switching of Gate D output to +4 volts is shown in Figure 3-26 at approximately 12  $\mu$ s after  $T_0$ . This positive output from Gate D ends the Memory Gating pulse. At the same time Gate D output shuts off current sources Q144 and Q154, causing the Arming and Output TD's to switch to their low state. With Output TD CR152 at its low state, conduction of Q174 stops (12  $\mu$ s after  $T_0$  in Figure 3-26).

When Q174 shuts off, Q184 also shuts off causing the pulse at the Pulse Out connector to end. A negative-going pulse is fed from the collector of Q184 through R185 to gate the Dot Position Memory during equivalent-time operation and to Q404 to reset the Ratemeter Ramp (Diagram 5).

When Q174 shuts off (12  $\mu$ s after  $T_0$  in Figure 3-26) the SWEEP RANGE switch hold-off capacitor connected to the junction of R174 and R176 starts charging toward +50 volts. When the voltage at the junction of these resistors is approximately 0.6 volts more positive than the 4.3 volts maintained at the base of Q104 by zener VR104, Q104 will turn on. The pin 1 input of Gate A has pulled itself positive since Q102 conducted only momentarily at the 1/2 hold-off interval (10  $\mu$ s to 12  $\mu$ s in Figure 3-26) when gates A and B switched. The pin 2 input has been held down by the input current supplied through R105.

As soon as the emitter of Q104 reaches +4.9 volts the current through R105 switches to Q104 and pin 2 of gate A pulls itself positive causing all gates to switch back to their original quiescent level. The current sources Q144 and Q154 for the Arming and Output tunnel diodes are turned on by the output of gate D and all circuits are again ready for the next trigger.

### Arming and Output Tunnel Diodes

Use Figure 3-21 to aid in understanding the following discussion. When the HF SYNC mode of triggering is selected, the signal source for the Arming TD and Output TD is the HF SYNC Oscillator (tunnel diode CR29, Diagram 1). Triggering energy is supplied through Q140A to Arming tunnel diode CR142, and through R152 to Output tunnel diode CR152.

In any mode other than HF SYNC the Schmitt Trigger circuit supplies the triggering signal to the Arming and Output tunnel diodes. Triggering signals are supplied to the Arming TD through Q140A while the Output TD is supplied through R151 and a section of signal path providing a 5 ns delay.

Output tunnel diode CR152 controls the state of the transistor differential pair Q162-Q164. This circuit provides output or controlling signals to a number of other circuits as shown in Figure 3-21.

In order for a small trigger signal to switch the Output tunnel diode to the high state, the Arming and Output tunnel diodes CR142 and CR152 respectively must first have sufficient arming current through them. Arming current for the Arming tunnel diode is supplied by the differential amplifier consisting of Q146 and Q144. Transistors Q154 and Q156 are used as a differential amplifier and provide the current source for the Output tunnel diode. The base of one transistor in each of the differential amplifiers is grounded (Q146 and Q156) while the voltage on the other bases (Q144 and Q154) is controlled by the HOMV (hold-off multivibrator).

When the output of Gate D of the HOMV (pin 11 of U110) is at approximately +4 volts, both Q144 and Q154 are shut off and neither tunnel diode can receive arming current. When the HOMV output switches to 0 volts the current sources for the tunnel diodes are turned on.

Current will increase to the armed value sooner in the Output tunnel diode than in the Arming tunnel diode due to a difference in the RC of components in the collector circuits. Providing the arming current is close to the armed value of CR142, the arrival of a trigger will switch CR142 to its high state. Switching CR142 to its high state increases the current through CR152 by about 3 mA. The Output tunnel diode is now fully armed and will switch to its high state as soon as the trigger that switched CR142 reaches it through the 5 ns delay line.

### Output T.D. Circuits

Refer to Figures 3-21 and 3-27 as well as Diagram 2, TRIGGER & HOLDOFF, in Section 8 of this manual to aid in understanding the following discussion.

**Trigger Pulse.** When Output tunnel diode CR152 is in the low state, current is flowing through transistor Q164 of the differential pair. When CR152 goes to the high state,

Q164 shuts off and Q162 turns on. Turning on Q162 sends a fast current pulse to Q212 and thence to Q230 of the Start Multivibrator. The Start Multivibrator then starts the TTH Ramp (Diagram 3, TIME TO HEIGHT CONVERTER).

**HOMV Drive.** When Output tunnel diode CR152 goes to its high state Q164 turns off, which turns on Q174. This starts the Hold-off Multivibrator cycle. The voltage at the junction of R174 and R176 starts dropping at a rate determined by the parallel resistance of R174 and R176 and the capacitance of C101.

**Pulse Out.** When Q174 turns on, Q184 also turns on rapidly. This shuts off grounded base stage Q186, interrupting a 10 mA current. Interrupting this current produces a 1/2 volt, positive-going output pulse into 50  $\Omega$ . (The output pulse is 10 volts or more if the output is open circuited).

**Blanking Logic.** No blanking is possible unless Q196 is turned on. Transistor Q196 will stay on as long as Q194 is shut off. Transistor Q194 is kept off by the peak detector (CR191, R191, C191, and R192) connected to its gate. Each time CR152 switches to its high level any slight loss in voltage on C191 is replaced. See Figure 3-11 and discussion under the heading of Blanking in the Circuit Theory part of this section.

### 3 TIME TO HEIGHT CONVERTER

A schematic diagram of the Time to Height Converter circuit is given on Diagram 3, in Section 8, Diagrams and Circuit Board Illustrations. The schematic is divided by grey shaded lines separating the circuitry into major stages. These stages aid in locating components mentioned here. Sub-headings in the following discussion use these stage names to further identify portions of the circuitry on Diagram 3.

#### Start Multivibrator

This circuit, formed by transistors Q230 and Q234, controls the start of the TTH and Slewing Ramps and provides logic for CRT blanking (see Figure 3-28). Transistor Q234 supplies a 22 volt negative drive pulse to the gate of the switching FET (Q294) in the TTH Converter, a 2/3 mA drive to the base of start transistor Q304 of the Slewing Ramp (Diagram 4), and Real-Time Retrace blanking logic to Q244. The Slewing Ramp is used only during equivalent-time sampling.

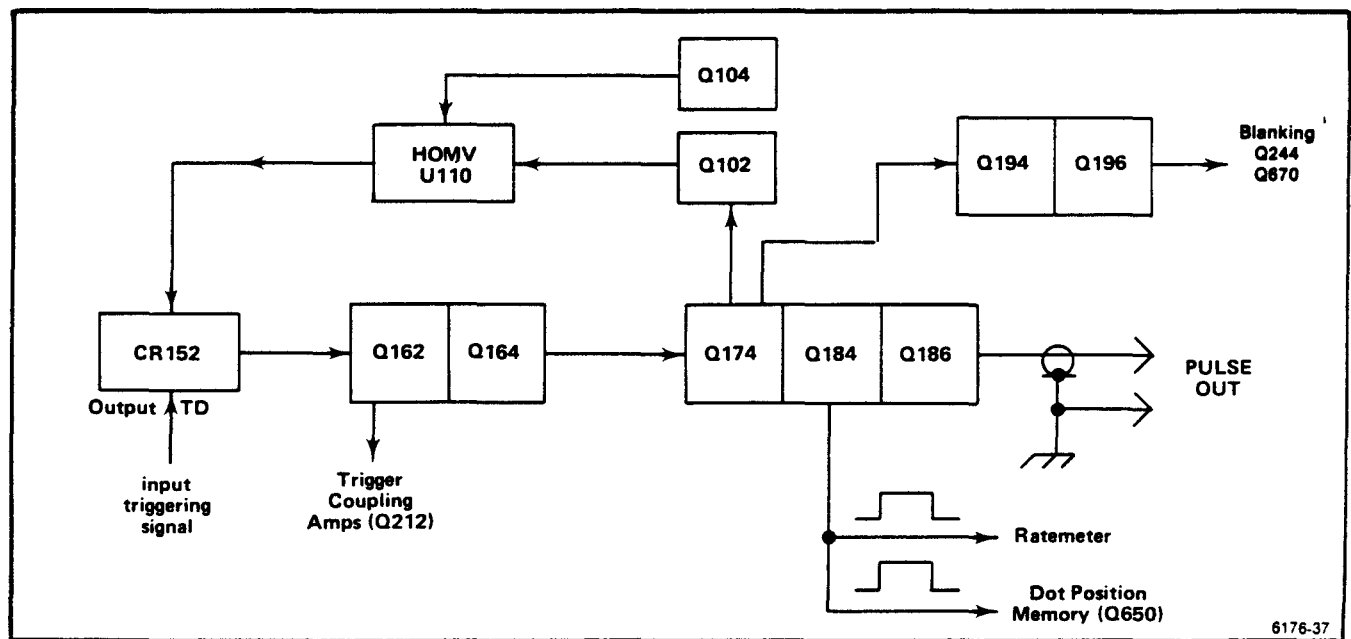

Figure 3-27. Trigger Output Circuits.

Transistor Q230 receives drive from either the Trigger Circuit (Diagram 2) by way of grounded base stage Q216 or from the Ratemeter (Diagram 5). The Ratemeter controls the Start Multivibrator only during Random sampling. The input from the Ratemeter is disabled in either Sequential Mode or the Real-Time Sampling Mode by transistor Q222. Voltage at the junction of resistor R224 and capacitor C224 together with the voltage at Random-Sequential switch S220 ensure conduction of Q222 during both Real-Time and Sequential operation.

The bias on this multivibrator is set so that both transistors shut off when no drive is applied to the base of Q230. The quiescent voltage at the collector of Q234 is  $-0.6$  volt, as set by CR234 and R234. The network CR295, CR296, CR294, R296 and R294 ensures that the gate of the switching FET Q294 is never forward biased. The arrival of a drive signal causes the two transistors to conduct heavily, switching the collector of Q234 to  $-22$  volts in about 15 nanoseconds. When the drive is removed, the transistors store for a microsecond or so, then shut off. TTH transistor Q294 recovers first; the Slew Ramp is delayed slightly by the inclusion of the diode - RC network in the base. This diode decoupling network is necessary to keep the Slewing Ramp from receiving false restarts (with resultant double strobing) from reset aberrations present in the TTH Converter.

Negative drive voltage of  $-22.5$  volts is used for the gate of FET Q294 because the TTH Converter output can fall as low as  $-10$  volts in normal operation. In order to ensure that the turn off bias of the gate is always greater than pinch off, it must be set at a voltage much lower than the lowest allowable level of either the drain or source. C294 and Gate Comp adjustment C237 counteract and equalize the FET gate blowby charge received during the start drive pulse. This blowby equalization is especially important when operating with the fastest range, where a 50 pF feedback capacitance is used. The ratio of gate-drain to feedback capacitance is large for this range.

### TTH Circuit

The Time to Height Converter is the key timing circuit in the 7T11A. It is essentially a Miller integrator formed by transistors Q280 and Q284, and feedback capacitors switched by the SWEEP RANGE control.

Figure 3-28 shows two outputs from the TTH Ramp Generator. One output is fed to Q446 of the Ratemeter Correction Memory (Diagram 5). The Ratemeter is used only during Random sampling and is discussed later in this section. The second output of the TTH Converter is fed to U512A at the input of the Horizontal Amplifier (Diagram 6), also discussed later in this section.

The TTH output ramp may be made to run positive or negative with respect to its zero volt starting point. During Real-Time and Sequential Sampling the TTH ramp may only run negative. During Random Sampling the direction the TTH ramp runs depends upon whether strobe or trigger occurs first.

The direction that the TTH ramp runs is determined by the TTH Slope control circuits (see Figure 3-28). With (−) Slope Driver Q262 supplying input to the Miller Integrator circuit, the Miller output ramp will be negative-going. When (+) Slope Driver Q272 supplies input current, the Miller output ramp is positive-going. Q262 and Q272 supply equal but opposite inputs. If both Q262 and Q272 are allowed to supply current to the feedback capacitors (C290, C291 and C292) the net result is no input and therefore no change at the Miller output.

To produce an output ramp, either Q262 or Q272 must be shut off. Conduction of Q252 will shut off (−) Slope Driver Q262, while conduction of Q228 will shut off (+) Slope Driver Q272. Another condition must be met if an output ramp is to be developed: Switching transistor Q294 must be shut off. When this transistor is ON, the input current is shorted around the feedback capacitors. Q294 provides a means of rapidly returning the Miller integrator output to the 0 volt level, thereby ending the TTH ramp.

When Output tunnel diode CR152 (Diagram 2) switches to the high state, Q162 turns on. This turns on Q212 and results in a negative pulse at the collector of Q216 and Q218. This negative voltage level remains at the output of Q216 and Q218 until the Output TD is switched back to its low level.

During Random operation the output of Q218 is used to drive Q228 into saturation. With Q228 saturated Q272 is reverse-biased. The (+) Slope drive to the Miller circuit is therefore cut off and remains cut off as long as the Output TD remains at its high level. During Real-Time and Sequential operation the output of Q218 has no effect on the (+) Slope Drive since the (+) Slope Driver is always off during these modes of operation. The same logic that causes Q222 to conduct, killing the Ratemeter input to the Start Multivibrator, also causes Q228 to remain on at all times during Real-Time or Sequential operation. The voltage at the junction of R221 and R223 causes Q228 to saturate shutting off (+) Slope Driver Q272.

As mentioned previously the Start Multivibrator (Q230 and Q234) may be turned on by either of two signals. During Real-Time and Sequential operation when Output TD

CR152 recognizes a trigger and switches to its high level, a negative pulse is delivered from the collector of Q216 to the base of Q230 causing both Q230 and Q234 to conduct. During Random operation the Ratemeter normally provides a negative pulse to the base of Q230 to turn on the Start Multivibrator. However, in the event that a trigger does occur before the Ratemeter delivers a start signal to Q230, the Start Multivibrator will be turned on by the output of Q216.

When Q234 turns on, a negative pulse is developed at its collector. The negative pulse from Q234 is fed through CR244 to the Slewing Ramp and to the gate of Q294. The negative voltage applied to the gate of Q294 shuts off Q294, permitting the Miller circuit feedback capacitors to start charging.

Two timing current sources are available. The +50 volt

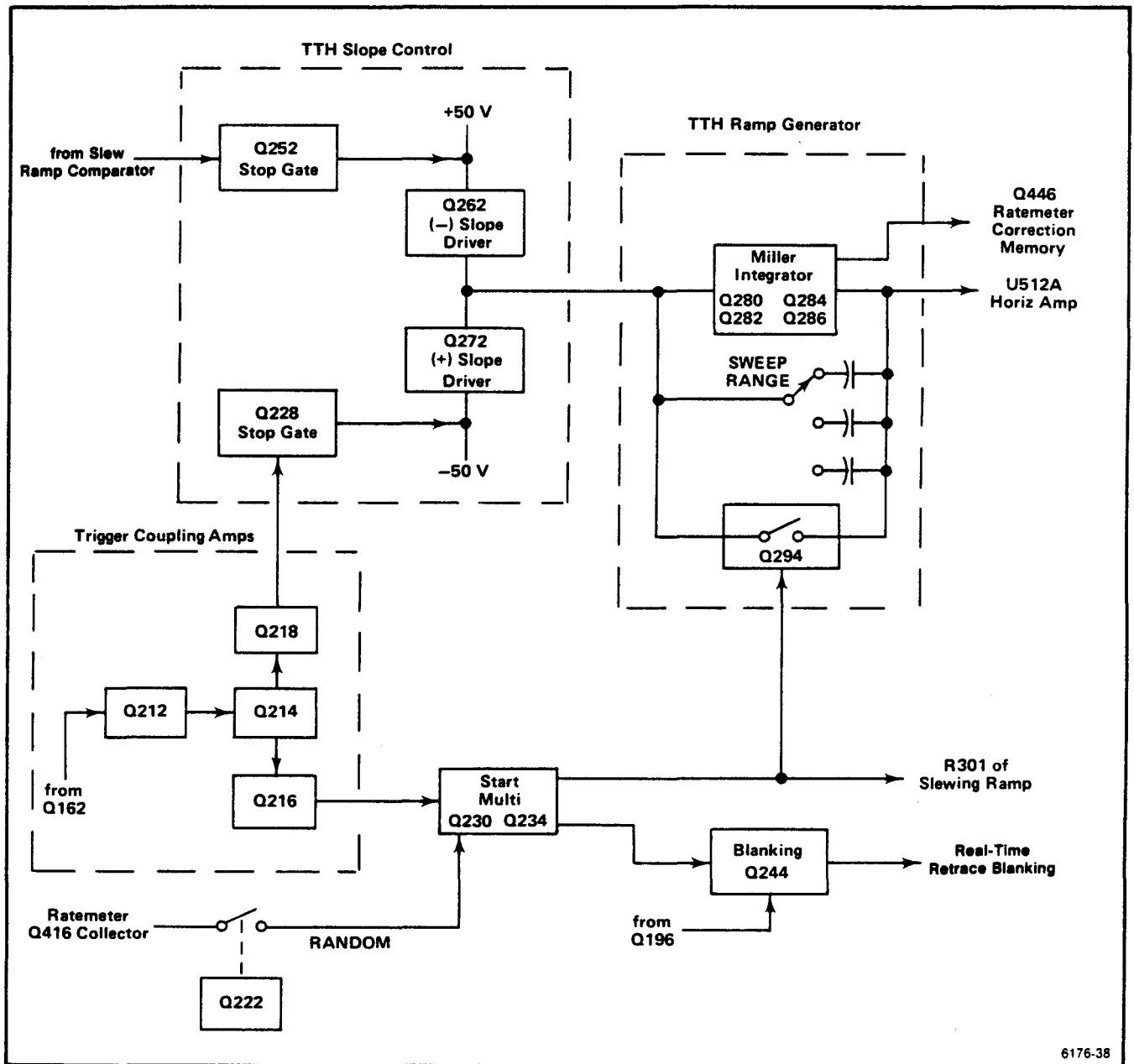
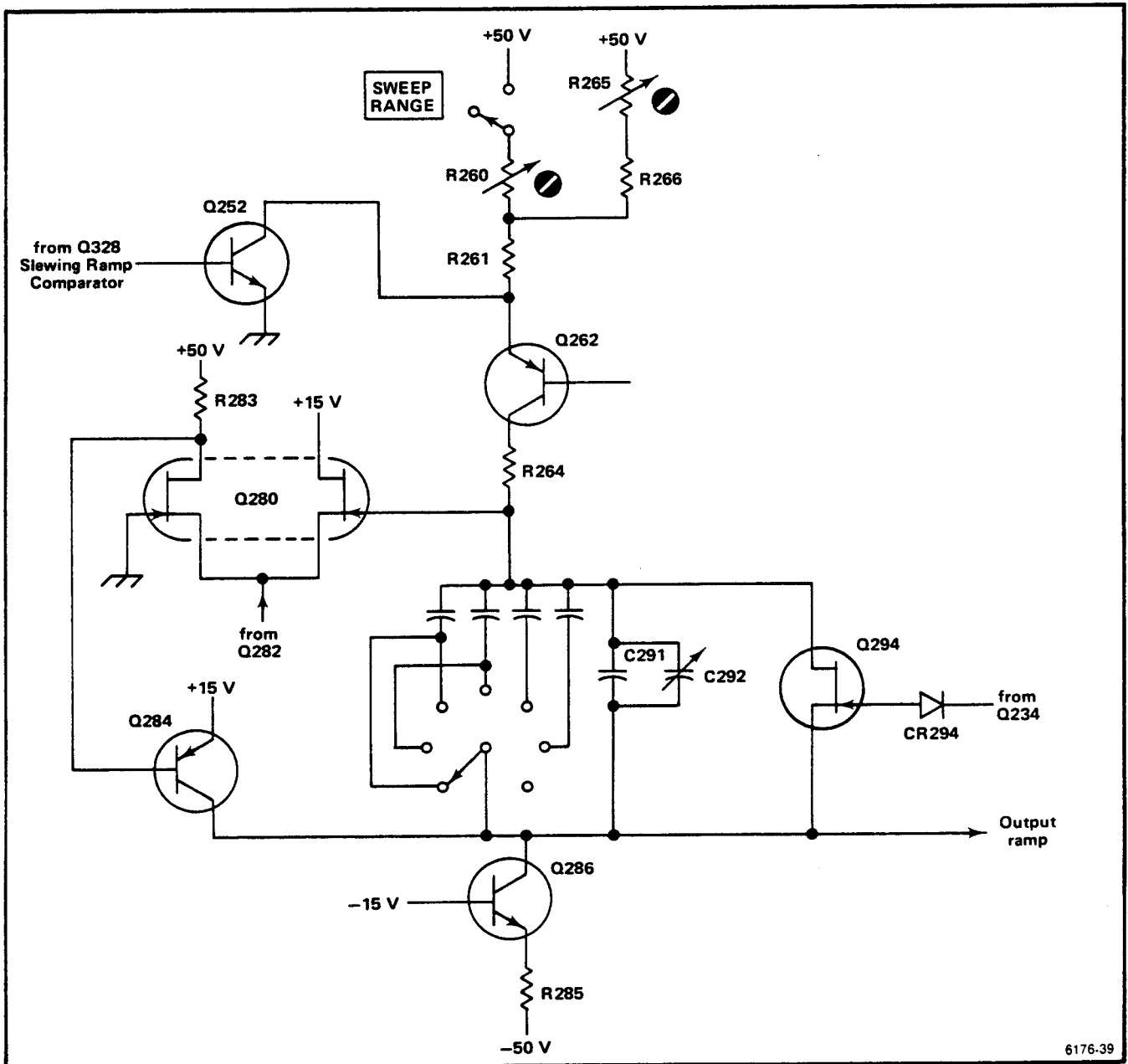

Figure 3-28. Block diagram of circuits shown on TIME TO HEIGHT CONVERTER schematic.

**Theory of Operation—7T11A**

supply and Q262 provide input current to drive the Miller output negative. The -50 volt supply and Q272 provide an input current in the opposite direction and cause a positive-going TTH Converter output. Q272 is shut off when any of the three real-time ranges are selected and during sequential equivalent-time operation. Q272 is also shut off during Random operation by the output of Q218 at the time of trigger recognition.

The path for (-) Slope Drive current when developing a negative-going TTH Converter output is shown in Figure 3-29. Current through Q262 results in a negative-going TTH ramp at the output of the Miller circuit provided that Q294 has been shut off by the Start Multivibrator and (+) Slope Driver Q272 is also shut off. Current through Q262 is stopped by driving (-) Slope Stop transistor Q252 into saturation. This is done only during equivalent-time sam-



**Figure 3-29. Active portion of the TTH circuit when producing a negative-going output ramp.**



ping. The (–) Stop signal is provided by Slewing Ramp Comparator transistor Q328 (Diagram 4).

Input current is 5 mA for all sweep Ranges except the two slowest; where it is switched to 50  $\mu$ A. The fastest ramp feedback capacitors are C291 and 50 ns Timing adjustment C292, and these are left across the Miller circuit at all times. The next slower sweep range uses 450 pF, followed by 0.00495, 0.05, and 0.5  $\mu$ F. The 0.05 and 0.5  $\mu$ F are each used at two settings of the SWEEP RANGE control; once for the two slowest sweep ranges when timing current is 50  $\mu$ A and again on the third and fourth positions of the SWEEP RANGE control when timing current is 5 mA. Fast Timing adjustment R260 is used to set the timing current to 5 mA for the five fastest Sweep Ranges. On the two slowest ranges, when the path through R260 is opened, the timing current is set to 50  $\mu$ A by Slow Timing adjustment R265. An adjustment corresponding to R265 is not needed for Q272 since the three slowest ranges are for Real-Time operation and Q272 never conducts on these ranges.

Figure 3-30 shows the equivalent circuit of the Miller integrator used to develop the TTH ramp. The 10K resistor represents the resistance of R260, R261, Q262 and R264. The 50 pF feedback capacitor represents the capacitance of C291 and C292. At the fastest SWEEP RANGE setting, the feedback capacitor consists of C291 and C292 in parallel. The +50 volt supply is providing a 5 mA input current.

The TTH Converter output voltage will theoretically change at a rate dependent upon the value of the feedback capacitor and the input current. The time (t) in seconds, for a given change in TTH Converter output voltage, can be found from the following relationship:

$$t = \frac{CV}{I}$$

Where: t = time in seconds

C = value of feedback capacitance in farads

I = input current in amperes

V = change in TTH Converter output voltage

At the fastest sweep rate the TTH Converter output does not move fast enough to keep up with the amount of charge being delivered to it by the 5 mA current source. Without capacitor C264 this lag in the TTH Converter output would result in a change in voltage at the TTH Converter input and possible saturation of the input current sources. Capacitor

C264 acts as a temporary charge storage device preventing the input of the TTH Converter from moving until the amplifier circuit has had a chance to operate and transfer the charge from C264 into the 50 pF feedback capacitor. After a period of time, but before the Horizontal Memory Gate pulse occurs, the TTH Converter output level finally represents the amount of charge gated into its input between start and stop commands.

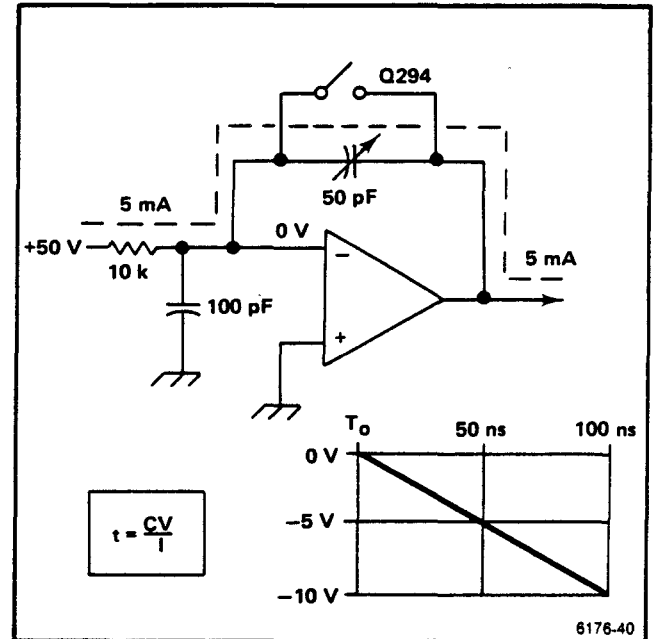

Figure 3-30. Equivalent circuit of Miller Integrator used to generate TTH ramp.

#### 4 SLEWING RAMP & RT MULTIVIBRATOR

A schematic diagram of the Slewing Ramp & RT Multivibrator circuit is given on Diagram 4, in Section 8, Diagrams and Circuit Board Illustrations. The schematic is divided by grey shaded lines separating the circuitry into major stages. These stages aid in locating components mentioned here. Sub-headings in the following discussion use these stage names to further identify portions of the circuitry on Diagram 4.

### Slewing Ramp Generator

The switching of Output TD CR152 (Diagram 2) to its high level causes the output of Q162 to go negative. The negative-going output of Q162 is fed to Q212, which results in a negative-going output from Q234 of the Start Multivibrator (Diagram 3). The negative pulse produced at the collector of Q234 starts both the TTH and Slew Ramps. Both of these ramps run at the same rate. The rate of change of the ramp voltage is dependent upon the setting of the SWEEP RANGE control.

Current through Q308 is set to 5 mA, or to a value producing a Slewing Ramp having the same slope as the TTH ramp. Slewing Ramp adjustment R310 is used to set this current level.

The 5 mA current is passing through Q306 just prior to trigger recognition. Immediately following trigger recognition, a negative-going pulse from Q234 drives Q304 into saturation. With Q304 saturated, Q306 is shut off and the 5 mA current is switched into the timing capacitor.

The parallel combination of C312 and C313 is used on the fastest sweep range. 50 ns Slewing adjustment C313 sets the Slewing Ramp slope equal to that of the TTH ramp on the fastest sweep range. Additional capacitance (C318) is switched in on each of the three remaining equivalent-time sweep ranges. The same amount of capacitance is added to the Slewing Ramp circuit as is added to the TTH Converter circuit.

As the constant 5 mA current charges the timing capacitor, the voltage at the base of Q318 runs down from 0 volts toward -15 volts.

### Slewing Ramp Comparator and Strobe Drivers

A voltage reference is provided by the Slow Ramp Inverter to the base of Q316. When the Slewing Ramp runs down to the level necessary to turn on Q316 and Q318, the ramp current is switched from the timing capacitor into a path through Q316 and Q318 thereby ending the rundown of the Slewing Ramp. The time duration of the Slewing Ramp rundown is dependent upon the voltage applied from the

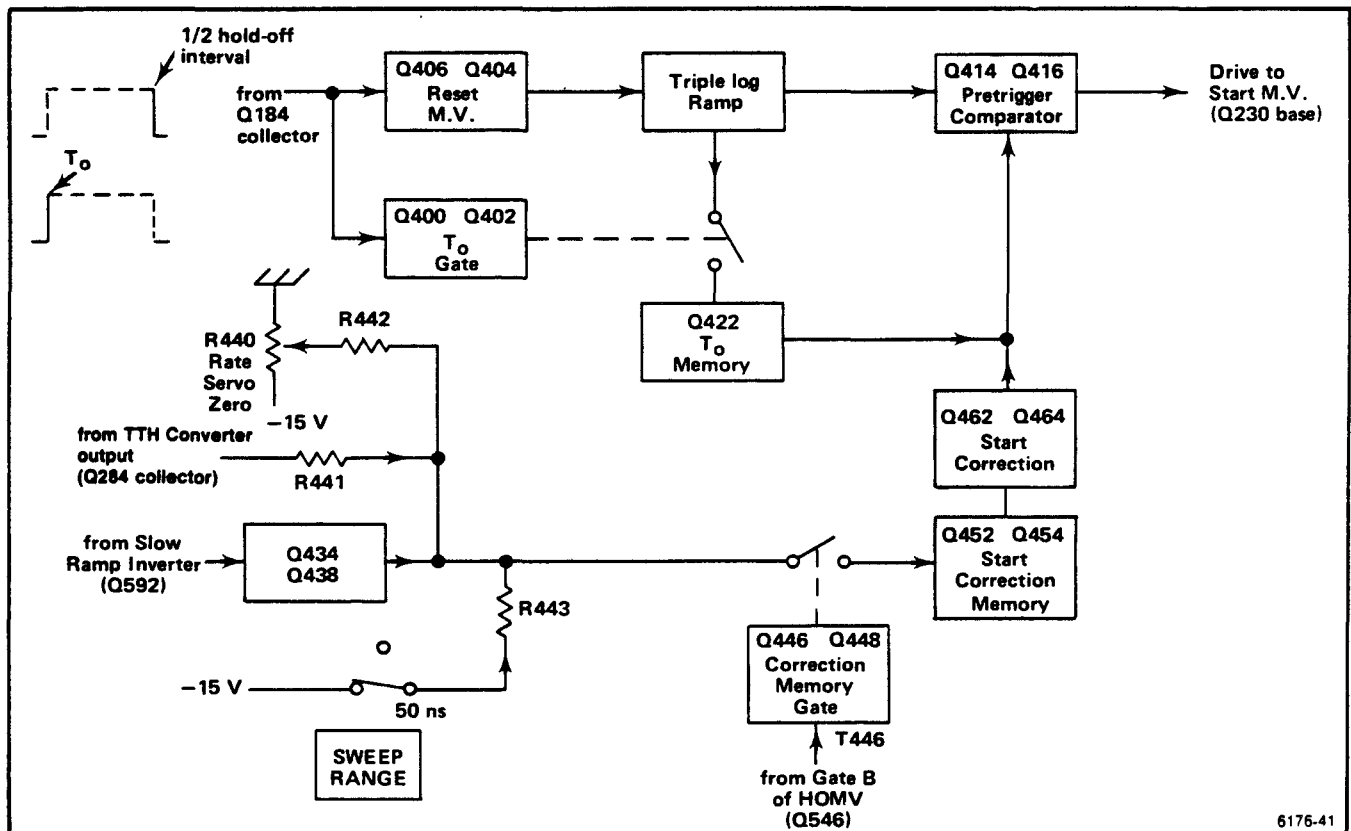

Figure 3-31. Simplified block diagram of Ratemeter circuit.

Slow Ramp Inverter to the base of Q316. When Q316 and Q318 turn on, Q322 turns on, causing transistor Q328 to switch to its high state. Switching of Q328 is prevented during real-time operation by conduction of Q326. During equivalent-time operation sufficient reverse bias is applied to the base of Q326 to insure that it remains shut off.

When Q328 switches to its high level, a fast drive pulse is provided to transistors Q342 and Q344, thence to the right and left-hand sampling units. The positive-going pulse appearing at the collector of Q328 is also fed through CR251 to Q252 in the TTH Converter circuit (Diagram 3). This turns on Q252 and Q252 saturates, shutting off the (–) Slope Drive to the TTH Converter and ending the rundown of the TTH ramp.

As was pointed out during the discussion of Random mode operation in the Circuit Theory portion of this section, during Random operation the TTH and Slewing Ramps do not normally start running together although a start pulse is delivered to the TTH Converter (gate of Q294) by the Start Multivibrator at the same time as the Slewing Ramp is started. Also the TTH ramp does not always run negative as it does during real-time and sequential operation. Other than the two exceptions just pointed out, the summary below applies to all modes of sampling.

To summarize, both the TTH and Slewing Ramps are started at the same time by Q234 (Start Multivibrator, Diagram 3) immediately after Output TD CR152 (Diagram 1) switches to its high state at time  $T_0$ . As shown in Figure 3-9, the TTH and Slewing Ramps both run negative at the same rate until voltage on the Slewing Ramp timing capacitor is negative enough to overcome the reverse bias between the base and emitter of Q316. When Q316 and Q318 conduct, the Slewing Ramp ends and Q328 is turned on. Q328 ends the rundown of the TTH ramp and causes Strobe Drivers Q342 and Q344 to deliver strobe pulses, thereby causing sampling of the vertical input signals. Q328 also provides a positive pulse to the base of Q368, which provides Interdot blanking.

### Real-Time Multivibrator

During real-time sampling the Real-Time Multivibrator provides a 3  $\mu$ s, positive-going drive pulse from the collector of Q362 to the emitter of Q546 (Diagram 6) at intervals of approximately 20  $\mu$ s. Memory Gate Driver Q546 applies this positive pulse to the gate of Q556, which connects the input of the Horizontal Memory (Q560) to the output of the Horizontal Amplifier for the 3  $\mu$ s gating interval.

During real-time sampling a positive-going 3  $\mu$ s duration pulse is also applied from the collector of Q362 to the base

of Q368. This enables Q368 and provides Interdot blanking for a 3  $\mu$ s interval.

The Real-Time Multivibrator consists of transistors Q352, Q356, and Q362. During real-time operation transistor Q326 conducts, clamping Q328 so that no outputs come from this source. Also during real-time operation the shield of the coaxial line to the right channel vertical unit is disconnected from ground by shutting off Q370. Removing the ground from the right channel coax shield permits the Real-Time Oscillator in the right-channel Sampling Unit to function. See Figure 3-17. This oscillator free-runs at about a 50 kHz rate and is frequency modulated at an approximate 200 Hz rate. The oscillator output is fed to the base of Q356 through CR348 and C348 as a series of positive pulses spaced at 20  $\mu$ s intervals.

When a trigger is received from the sampler, Q356 conducts, driving Q352, which drives Q356. Transistor Q362 also conducts, driving both the Horizontal Memory Gate and Interdot blanking circuit. The feedback from Q352 to Q356 is through C358 and diode CR358. When the base side of C358 has charged to a negative level that shuts off Q356, transistors Q352 and Q362 are shut off. Resistor R357 provides a discharge path for C358, allowing the collector of Q352 to return to ground. The output of the Real-Time Multivibrator appears at the collector of Q362 as a 3  $\mu$ s positive pulse.



## RATEMETER

A schematic diagram of the Ratemeter circuit is given on Diagram 5, in Section 8, Diagrams and Circuit Board Illustrations. The schematic is divided by grey shaded lines separating the circuitry into major stages. These stages aid in locating components mentioned here. Sub-headings in the following discussion use these stage names to further identify portions of the circuitry on Diagram 5.

### General

The purpose of the Ratemeter (see Figure 3-31) is to start the displayed portion of the sweep before a trigger arrives, thus permitting time before triggering can be displayed. The Ratemeter estimates when the next trigger will occur by measuring time from Ratemeter reset (1/2 hold-off interval) to the next trigger recognition, or  $T_0$ .

### Pretrigger Comparator

Pretrigger Comparator Q414-Q416 is responsible for delivering an output, from the collector of Q416 to the base of Q230, to get the trace started prior to arrival of the triggering signal. The Pretrigger Comparator will deliver an output pulse when Q416 conducts. Conduction of Q416 occurs when Q414 is shut off. Transistor Q414 shuts off when its base voltage reaches a more negative voltage than is present at the base of Q416.

The voltage at the base of Q414 is determined by the voltage to which capacitor C414 in the Triple Log Ratemeter Ramp has charged. The voltage at the base of Q416 can be considered to be the result of the output of two sources. These two sources are the output of Q422, supplied through R424, and the output of the Start Correction circuit taken from the collectors of Q462 and Q464. The Start Correction input will be discussed after the Ratemeter outputs supplied to the base of Q414 and Q416 are explained.

### Triple Log Ramp

The Triple Log Ramp consists of R408 and R409 serving as the source of charging voltage for the ramp, resistors R411 and R412, capacitors C411, C412, and C414 and two diodes. Resistors R408 and R409 together with the -50 volt supply can be considered to be a source of approximately -15 volts and having a resistance of about 12 k $\Omega$ . This 12 k $\Omega$  resistor in parallel with R411 and R412 forms a divider network that charges C414 to a negative voltage of about -5 volts, or 1/3 of 15 volts. The time constant is 80  $\mu$ s (see Figure 3-32), set by C414 and the parallel combination of the four resistors. Charging starts immediately after the network is discharged by the Reset Multivibrator.

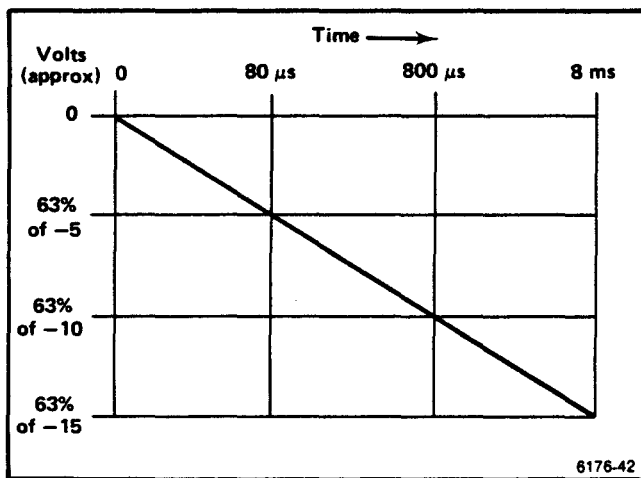

Figure 3-32. Theoretical change in voltage of Ratemeter Triple Log Ramp capacitor (C414) with charging time.

After the network reaches the -5 volt level, C412 charges toward -10 volts from 0 volts with a time constant of C412 (R412 + parallel resistance of R411, R408, and R409) or approximately 800  $\mu$ s. As C412 charges, the junction of the 4 resistors slides from -5 volts to -10 volts. Then C411 begins to charge from 0 volt to -15 volts with a time constant of C411 (R411 + parallel resistance of R408 and R409) or about 8 ms. The junction of the four resistors slides from -10 volts to -15 volts during this time.

The Triple Log Ramp eliminates the need to switch Ratemeter capacitors when the Sweep Range setting is changed and to specify lower limits for trigger repetition rate for each Sweep Range.

### Reset Multivibrator

The Reset Multivibrator (Q404 and Q406 of Figure 3-31) is used to discharge the capacitors in the Ratemeter Ramp network. The Reset Multivibrator is turned on at 1/2 hold-off interval by the negative-going portion of the pulse supplied by Q184 (Diagram 2). This pulse coincides in time with the time during which Trigger Output TD CR152 is reset to the low state. The negative-going portion of this pulse is fed through C402 to the base of the Reset Multivibrator. Turning on the Reset Multivibrator discharges the negative charge on C411, C412 and C414.

Discharge of C411 and C412 occurs through the low resistance path offered by CR411 and CR412 respectively. After reset, conduction of the diodes stops.

### T<sub>0</sub> Memory and T<sub>0</sub> Gate

The purpose of the T<sub>0</sub> Memory is to supply an input to the Pretrigger Comparator that is an indication of what length of time interval existed between the 1/2 hold-off interval and trigger recognition (T<sub>0</sub>), during the previous run of the Ratemeter Ramp.

The input supplied to the base of Q416 by T<sub>0</sub> Memory transistor Q422, is dependent upon the charge on C421. The charge on T<sub>0</sub> Memory capacitor C421 is determined by the voltage of the Ratemeter Ramp at the time the T<sub>0</sub> Gate is turned on. The T<sub>0</sub> Gate is turned on by the positive-going portion of the pulse appearing at the collector of Q184 (Diagram 2). The positive-going portion of this pulse results from the Trigger Output TD switching to its high level when it recognizes a trigger. This pulse is coupled through C401 to transformer T400 and appears as a negative pulse at the emitters of T<sub>0</sub> Gate transistors Q400 and Q402. Diode CR400 limits base-emitter reverse bias to a few tenths of a volt.

When the  $T_0$  Gate transistors are turned on, the  $T_0$  Memory capacitor C421 is connected to the Ratemeter Ramp network through the low resistance of the Gate transistors. With the Gate turned on, C421 adjusts its voltage to that of the Ratemeter Ramp. If a constant trigger repetition rate is assumed, the Ratemeter always reaches the same level between reset and  $T_0$ .

With a constant trigger repetition rate and ignoring the signal delivered by the Start Correction circuit (Q462 and Q464), the Pretrigger Comparator will deliver an output at time  $T_0$ . The Ratemeter seems to be serving no purpose since it's desired to start the trace before time  $T_0$ . Actually, the circuits discussed provide an input to the base of Q416 that is dependent upon trigger repetition rate. The time between outputs from the Pretrigger Comparator will quickly adjust to the new  $T_0$  time interval. The leadtime required to get the trace started prior to trigger recognition is provided by the signal delivered by the Start Correction circuit (Q462 and Q464).

If the triggering interval is very random, it is possible for trigger recognition to occur part of the time prior to Pretrigger Comparator output in spite of the leadtime provided. This presents no problems however, but results in the Start Multivibrator being turned on by the trigger instead of the Pretrigger Comparator. The vertical input will be sampled and the sample displayed following  $T_0$  by a time interval dependent upon the value of the Slow Ramp Inverter output.

### Start Correction

Leadtime and start correction inputs are delivered to the base of Pretrigger Comparator transistor Q416 from the collectors of Q462 and Q464. Figure 3-31 shows that the sum of four inputs can be connected to the Start Correction Memory (Q452 and Q454) by turning on the Correction Memory Gate.

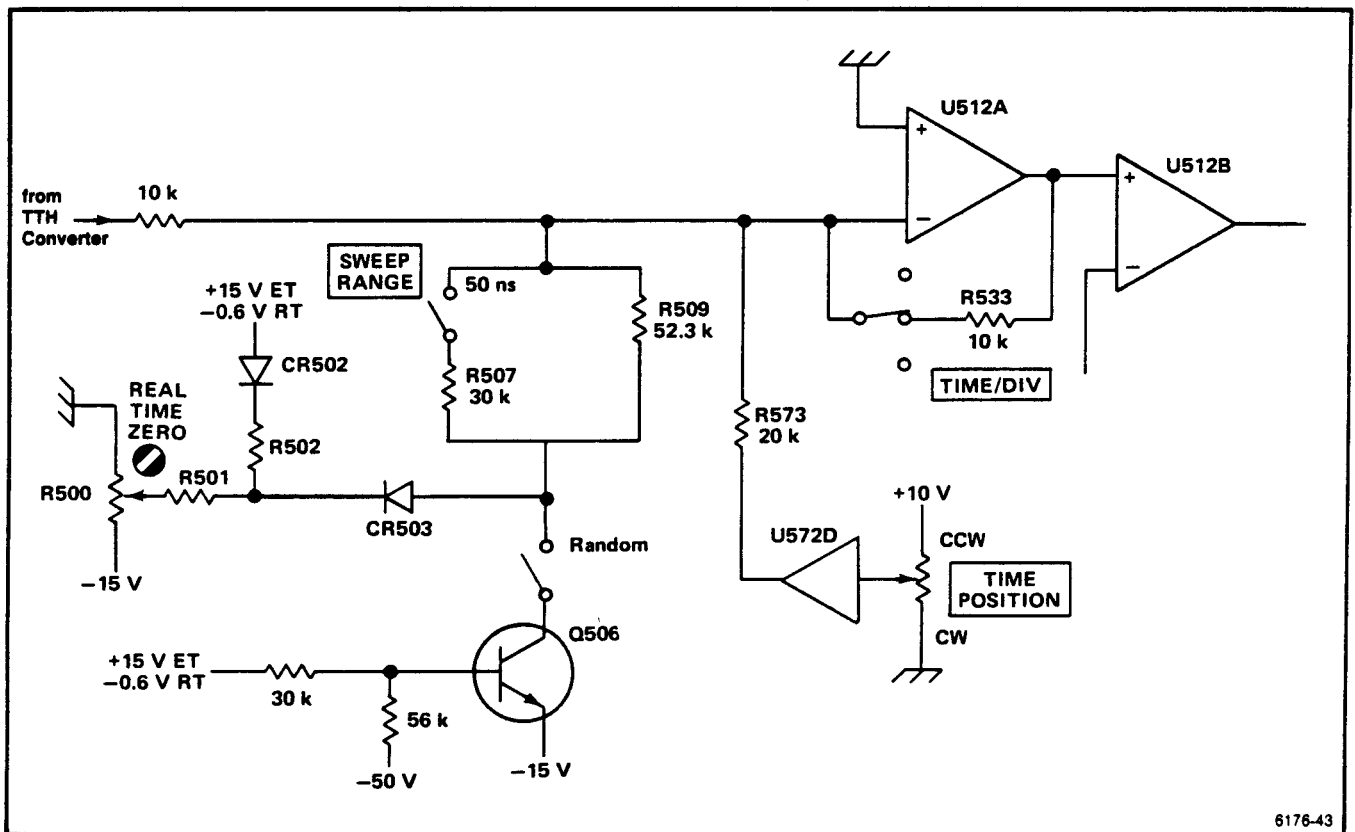

Figure 3-33. Simplified diagram showing sources of Horizontal Amplifier offset current.

6176-43

## Theory of Operation—7T11A

The four inputs are from Rate Servo Zero adjustment R440, TTH Converter output (Diagram 3), Slow Ramp Inverter (Diagram 8), and the -15 volts supplied through R443 at the fastest setting (fully CCW) of the SWEEP RANGE switch. The TIME POS RNG is 50 ns at this setting.

Rate Servo Zero adjustment R440 provides the 1/2 TPR (time positioning range) of leadtime introduced during the Random Mode of operation. An additional 50 ns of leadtime is introduced at the fastest Sweep Range setting by the input through R443.

The TTH Converter and Slow Ramp Inverter inputs provide correction if the TTH and Inverter output voltages do not differ by the correct amount for the intended leadtime. If the output of the Pretrigger Comparator is too early, possibly due to an increase in time between triggers, the TTH Converter output will be more positive with respect to the Slow Ramp Inverter output than it should be. When Gate transistors Q446 and Q448 are turned on, a less negative than normal voltage will be stored on C451. This results in a more negative voltage at the base of Pretrigger Comparator transistor Q416 and delays firing of the Pretrigger Comparator.

Transistor Q434 provides inversion of the negative-going output of the Slow Ramp Inverter. Gating transistors Q446 and Q448 are turned on by a pulse induced in the secondary of T446 when a pulse is applied to the primary of T446. Diode CR446 prevents the negative-going portion of the applied pulse from inducing an excessive reverse-bias voltage across the base-emitter junction of Q446 or Q448.

The pulse that turns on Gate Transistors Q446 and Q448 is the same as that used for Horizontal Memory drive. At 1/2 Holdoff time Q546 (Diagram 6) turns on and a positive-going pulse is coupled through CR547 to the bottom of transformer T446 primary. This positive-going pulse turns on Q446 and Q448 except when Q694 (Diagram 7) is turned on. Q694 is turned on during Slow Ramp Generator retrace time and during Sequential or Real-time operation. With Q694 conducting, the top of T446 primary is grounded. This reverse biases diode CR547 and prevents coupling of the positive pulse to T446.



## HORIZONTAL AMPLIFIER

A schematic diagram of the Horizontal Amplifier circuit is given on Diagram 6, in Section 8, Diagrams and Circuit Board Illustrations. The schematic is divided by grey shaded lines separating the circuitry into major stages. These

stages aid in locating components mentioned here. Sub-headings in the following discussion use these stage names to further identify portions of the circuitry on Diagram 6.

### Amplifier

Nine TIME/DIV settings are available at each of the seven positions of the SWEEP RANGE control. The gain of the Horizontal Amplifier is determined by the setting of the TIME/DIV control. The Horizontal Amplifier gain is changed in a X1, X2.5, X5 sequence as the TIME/DIV control is rotated clockwise. See Table 3-1.

**TABLE 3-1**  
Effect of TIME/DIV Control  
on Horizontal Amplifier Gain

TIME/DIV position	Gain provided by			Total Horizontal Amplifier Gain
	U512A	U512B	U512D	
CCW 1	X1	none	none	X1
2	X2.5	none	none	X2.5
3	X5	none	none	X5
4	X1	X10	none	X10
5	X2.5	X10	none	X25
6	X5	X10	none	X50
7	X1	X10	X10	X100
8	X2.5	X10	X10	X250
CW 9	X5	X10	X10	X500

An integrated circuit consisting of four operational amplifiers is used as the Horizontal Amplifier. The four stages of amplification are designated as U512A, U512B, U512D and U512C respectively on the schematic and block diagrams.

In the calibrated position, the first stage (U512A) provides a gain of X1, X2.5, or X5. This gain is set by R533, R534, or R536 together with R287 (Diagram 3). Resistors R535 and R537 are used to ensure that a 10 k impedance is seen looking from the output back to the input on the X2.5 and X5 gain positions. This ensures that the front-panel VARIABLE control will provide the same variable ratio as provided on the X1 position. The input signal is inverted in passing through the first stage (U512A) of the Horizontal Amplifier.

Time positioning current is injected at the input of U512A to offset the dynamic range of the amplifier. See Figure 3-33. Time positioning permits the Horizontal Amplifier to amplify different portions of the TTH Converter output. The TIME POSITION control permits the start of the displayed sweep to be delayed after trigger recognition by an amount dependent upon the setting of the TIME POSITION control. The maximum time position current of 0.5 mA, with the control fully CCW, produces a 5 volt shift at the Horizontal Amplifier input. The TTH ramp must now run down to  $-5$  volts before being recognized as an input signal by the Horizontal Amplifier. The coarse control accounts for practically all of this current; the FINE control has only a one percent effect.

On real-time sweep ranges Real Time Zero adjustment R500 is operative. This adjustment permits the start of the real-time sweep to be on screen, even in magnified positions of the TIME/DIV switch, by applying an offset current through R509. In equivalent-time operation, the Real Time Zero adjustment is disabled by applying  $+15$  volts to the anode of CR502.

Two other paths for supplying the input of the Horizontal Amplifier with offset current are also shown in Figure 3-33. Both of these paths are used only during random equivalent-time sampling. When random sampling is used, a path for offset current is provided through Q506 and R509. The direction of this current is opposite that provided by the TIME POSITION control. This circuit therefore introduces lead time offset. For the 50 ns range, random mode, an additional offset current is provided through R507. This additional current provides the additional 50 nanoseconds of lead time needed for display of a triggering edge.

Transistors Q512, Q514 and Q524 serve as clampers and prevent driving the operational amplifiers of the Horizontal Amplifier into saturation.

The second and third stages of amplification, U512B and U512D, each provide X10 gain when used. At a given setting of the Sweep Range control, the equivalent-time sweep rate is directly proportional to the gain of the Horizontal Amplifier.

The last stage of the Horizontal Amplifier (U512C) provides a power gain. This stage must supply a maximum of 5 mA to the input of the Horizontal Memory and 2 mA to the HOMV reset circuit.

### Horizontal Memory Gate Driver

The driver for the Horizontal Memory Gate is Q546. During real-time operation, the voltage applied to R543 and

R541 drops to  $-0.6$  volts. This voltage shuts off Q544 and saturates Q542. The base input of Q546 is now grounded and the emitter is not. The positive-going memory gating pulse, from the collector of Q362 (Diagram 4), is applied to the emitter of Q546 and is coupled through Q546 to the gate of Q556. In equivalent-time operation, Q544 is saturated by the  $+15$  volts applied to R543 during equivalent-time operation. With Q544 saturated, the emitter input of Q546 is grounded. However, Q546 can still be turned on by applying a negative-going memory gating pulse from the HOMV to the base of Q546.

Transistor Q552 is a variable-gain amplifier used to correct memory offset caused by blowby of the gating signal applied to Q556. R547 ensures that some reverse bias still remains at the gate of Q556 with the positive going pulse applied.

An output is taken from the junction of R547 and R548 to drive the Start Correction Memory of the Ratemeter Servo (Diagram 5). It is used only when operating in Random Equivalent-Time.

### Horizontal Memory and Gate

The Horizontal Memory is a Miller integrator similar to that used in the TTH Converter. The feedback capacitor is C566. The input of the Miller is formed by dual FET Q560. The output of this differential amplifier is fed to the base of Q564. The signal appearing at the collector of Q564 is inverted from that applied to the input of Q560. Resistors R556 and R558 set the X2 gain of the Horizontal Memory. Resistor R557 shifts the output voltage swing of Q564 to  $+5$  V to  $-5$  V for inputs of 0 V to  $+5$  V. Thus, both an inversion and a level shift is made.

The output level at the collector of Q564 is set by causing Memory Gate FET Q556 to conduct. Q556 is gated on by turning on Q546. A positive-going memory drive pulse applied to the emitter of Q546 during real-time sampling, or a negative-going pulse fed to the base of Q546 during equivalent-time operation, will supply a positive pulse to the gate of Q556. With a positive gating pulse applied to Q556, the output of Horizontal Drive Amplifier U512C is connected to the input of Q560; the output of the Memory is also connected to its input through R558.

During gate conduction time, C566 tends to slow down the response of the Horizontal Memory circuit. The response is determined by the 100 ns RC time of C566 and R558. A 2 or 3  $\mu$ s wide memory gate drive pulse is used to insure 100% sampling efficiency. When the gate pulse ends and causes the FET gate to stop conducting, the Horizontal

Amplifier and feedback resistor R558 are disconnected from the input. Memory capacitor C566 retains the final voltage reached by the amplifier until the next strobe occurs. Output of the Horizontal Memory is fed to the SWEEP OUT connector on the front panel and to integrated-circuit output amplifiers U572A and U572B.



## SLOW RAMP GENERATOR & OUTPUT AMPLIFIER

A schematic diagram of the Slow Ramp Generator and Output Amplifier circuit is given on Diagram 7, in Section 8, Diagrams and Circuit Board Illustrations. The schematic is divided by grey shaded lines separating the circuitry into major stages. These stages aid in locating components mentioned here. Sub-headings in the following discussion use these stage names to further identify portions of the circuitry on Diagram 7.

### Slow Ramp Generator - REP SCAN

Refer to the block diagram of Figure 3-34 during the following discussion. The slow ramp is generated by the Miller integrator consisting of transistors Q634 and Q636 and dual FET Q616. During REP Scan operation, the input signal is applied to Q616B while Q616A is grounded through R619. Transistor Q618 is the current source for Q616. The positive-going 10 volt Slow Ramp output is taken from the collector of Q636. Transistor Q634 terminates the output ramp when the collector of Q636 reaches approximately +10.2 volts.

Since the ramp can only run from 0 volts to approximately +10 volts before being reset, the slope and time duration of the output ramp is dependent upon R615 and C620, and the voltage at the collector of Q612. The voltage at the collector of Q612 can be set at any value of voltage between approximately -15 volts and 0 volts, using the SCAN control. The SCAN control provides a means of changing the slope and therefore the time duration of the ramp. With Q612 shut off, R612 and R613 set the emitter of Q612 at approximately +10 volts.

With the SCAN control fully clockwise, the wiper of SCAN control R610 is connected to the +10 volt end of the control and Q612 current is shut off. This produces approximately -15 volts at the collector of Q612 and provides maximum input current through R615 to the Miller circuit. Turning the SCAN control counterclockwise permits increasing values of current through Q612 (up to a maximum of about 0.1 mA with the wiper of R610 at the ground end of the control).

Turning the SCAN control CCW reduces the input current to the Miller circuit and therefore reduces the slope of its output ramp. A longer time is therefore required for the ramp to run from 0 V to +10 volts. Since the ramp is running at a slower rate, more samples will be taken during a sweep, but fewer sweeps per second will be displayed.

Conditions just prior to run-up are: Gating transistor Q620 is on, thereby preventing run-up of the ramp; transistor Q662 is off, which provides Slow Ramp Retrace blanking to the CRT; and Reset Multivibrator transistors Q628 and Q626 are both off. The TTH and Slewing Ramps, as well as the trigger and HOMV circuits are going through their normal cycles of operation.

The output pulse from gate A of the HOMV (Diagram 2) is applied to the base of Q628 through C630. Gate A output of the HOMV drops from approximately +4 volts to 0 volts as the HOMV resets to a ready for trigger condition. Provided sufficient time has elapsed since termination of the previous slow ramp, the negative pulse from the HOMV turns on Q628, which turns on Q626. Conduction of Q626 latches Q628 ON so that neither positive nor negative-going pulses from the HOMV will change the state of Q628 during the remainder of the slow ramp run-up. Conduction of Q626 also shuts off Gating transistor Q620, permitting the start of the slow ramp run-up and turning on transistor Q662, thereby removing Slow Ramp Retrace blanking of the CRT.

The Slow Ramp Generator output voltage (collector of Q636) slowly rises from 0 volts to +10 volts at a rate determined by the setting of the SCAN control. During this slow rise, triggering signals are being recognized and the TTH and Slewing Ramps are periodically started and stopped.

The Slow Ramp output voltage charges C631 through CR631 and is also applied to the emitter of Q634. When the emitter of Q634 reaches approximately +10 volts, Q634 is turned on. Current through Q634, R634, and CR627 shuts off Q628, which shuts off Q626. When Q626 shuts off, Q620 turns on discharging C620 and resets the slow ramp output voltage to zero. When Q626 shuts off, transistor Q662 is shut off resulting in Slow Ramp Retrace blanking of the CRT.

When Q662 shuts off, Gate Control transistors Q644 and Q694 are both turned on. The conduction of Q644 prevents Dot Position Gating transistor Q650 from being turned on by an output from Q184 (Diagram 2) during Slow Ramp Retrace time. The conduction of Q694 prevents turn on of Ratemeter Correction Memory Gating transistors Q446 and Q448 (Diagram 5) by the output of Q546 during Slow Ramp Retrace time.



Transistor Q628 is switched off by the conduction of reset transistor Q634. Although resistor Q634 shuts off almost immediately due to loss of forward bias resulting from the turn on of Q620, transistors Q628 and Q626 remain shut off. Capacitor C631 is charged to approximately 10 volts and its discharge through R631 and CR627 holds off the Reset Multivibrator (Q628 and Q626) until the Slow Ramp Generator circuit has had time to reset and stabilize. When the current delivered through C630 (by a negative-going pulse from Gate A of the HOMV, Diagram 2) exceeds the current discharging C631, diode CR627 will shut off and Q628 will be turned on. Q628 then turns on Q626 as the cycle repeats itself.

### Blanking

Slow Ramp Retrace blanking occurs when Q662 is shut off. With Q662 shut off Q668 conducts. Conduction of Q668 turns on Q670, which produces blanking. Overrun blanking also drives Q8. If the output of U572A or U572B exceeds +5 volts, Q8 will be turned on. Q8 then turns on Q2 and Q3 to blank the crt display through interface connector A17.

Slow Ramp Retrace blanking is disabled or inhibited by turning on Q662. As previously mentioned, Q662 is turned on by the negative voltage at the collector of Q626 during run-up of the Slow Ramp. Slow Ramp Retrace blanking is therefore prevented during this time. Q662 can also be turned on, disabling retrace blanking by turning on Q664. Transistor Q664 is turned on when the MAN or EXT INPUT SCAN pushbutton is pushed in. A voltage of +15 volts is delivered by switch S610 to R665 which turns on Q664. Transistor Q664 can also be turned on, disabling retrace blanking, by selecting one of the three real-time Sweep Ranges. This is accomplished by Q608. Since the Slow Ramp Generator is not disabled during real-time operation, Slow Ramp blanking would occur during real-time operation on REP SCAN except for the disabling action of Q608. Conduction of Q608 also keeps gating transistor Q620 turned on, preventing slow ramp run-up, and holds Q628 and Q626 of the Reset Multivibrator off.

Interdot blanking is disabled until Q368 (Diagram 3) receives a trigger signal because the base and emitter of Q368 are held high by pin 6 of U110B and Q196 (Diagram 2). When a trigger signal is received by Q196, it enables

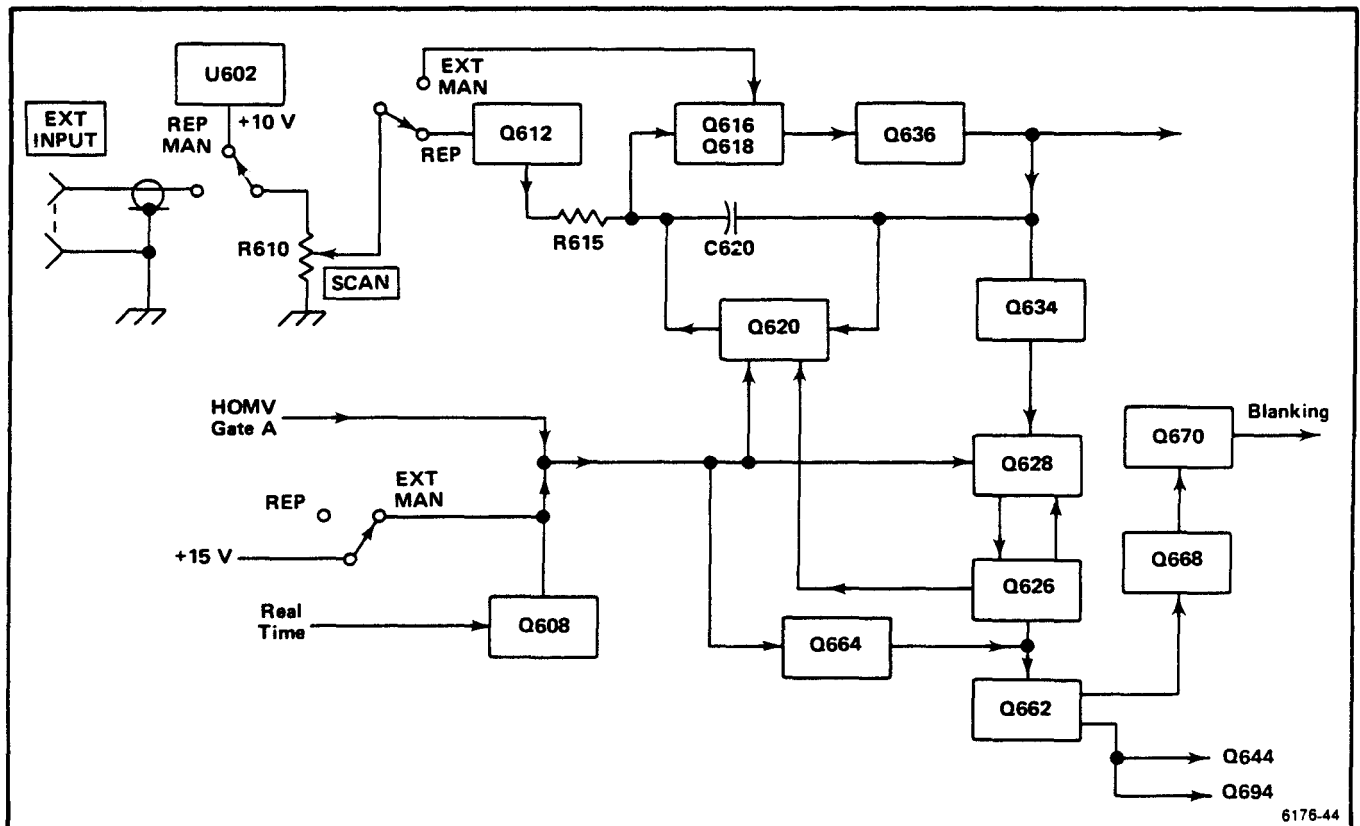

Figure 3-34. Slow Ramp Generator block diagram.

## Theory of Operation—7T11A

Q368 by pulling its emitter low. Q368 then drives Q2 to provide a positive CRT blanking signal at output connector A17. The CRT blanking signal will remain high at A17 until Q368 is turned off.

Blanking can also occur when Q8 is turned on by the Horizontal Amplifier circuit (Diagram 6). The emitter of Q8 is connected to R671 at the output of the Horizontal Amplifier and is biased on whenever the Horizontal Amplifier output exceeds +5 volts (Overrun). Q8 then drives Q3, Q2, and Q1 to provide a positive blanking level at output connector A17. The purpose of this Overrun blanking configuration is to keep undesirable portions of the sweep from being displayed on the CRT.

Q4 and Q5 give the mainframe control over when blanking can occur by switching Q1 on and off. Blanking can only occur when either of these transistors is turned on by the mainframe's control logic through interface connectors B7 of A16. This ensures that the 7T11A can only cause CRT blanking during its allotted display time.

Q6 inverts the signal at output connector A1 to provide a positive gate pulse to the mainframe through output connector B4 at the end of each 7T11A sweep.

## MAN and EXT INPUT SCAN

When the MAN or EXT INPUT is selected, the REP pushbutton is released to the out position. When in the out position, a contact of the REP pushbutton is connected to the +15 volt supply. This voltage prevents Slow Ramp Retrace blanking by turning on Q664 which turns on Q662. Q662 is normally on only when Reset Multivibrator Q626 and Q628 are on during generation of a slow ramp. The +15 volts mentioned above also keeps the Reset Multivibrator turned off and turns on Q620. With Q620 turned on, the collector of Q636 is connected to the gate of the left section of Q616.

When the MAN SCAN pushbutton is pushed in, Q616 and Q636 of the Slow Ramp Generator function essentially

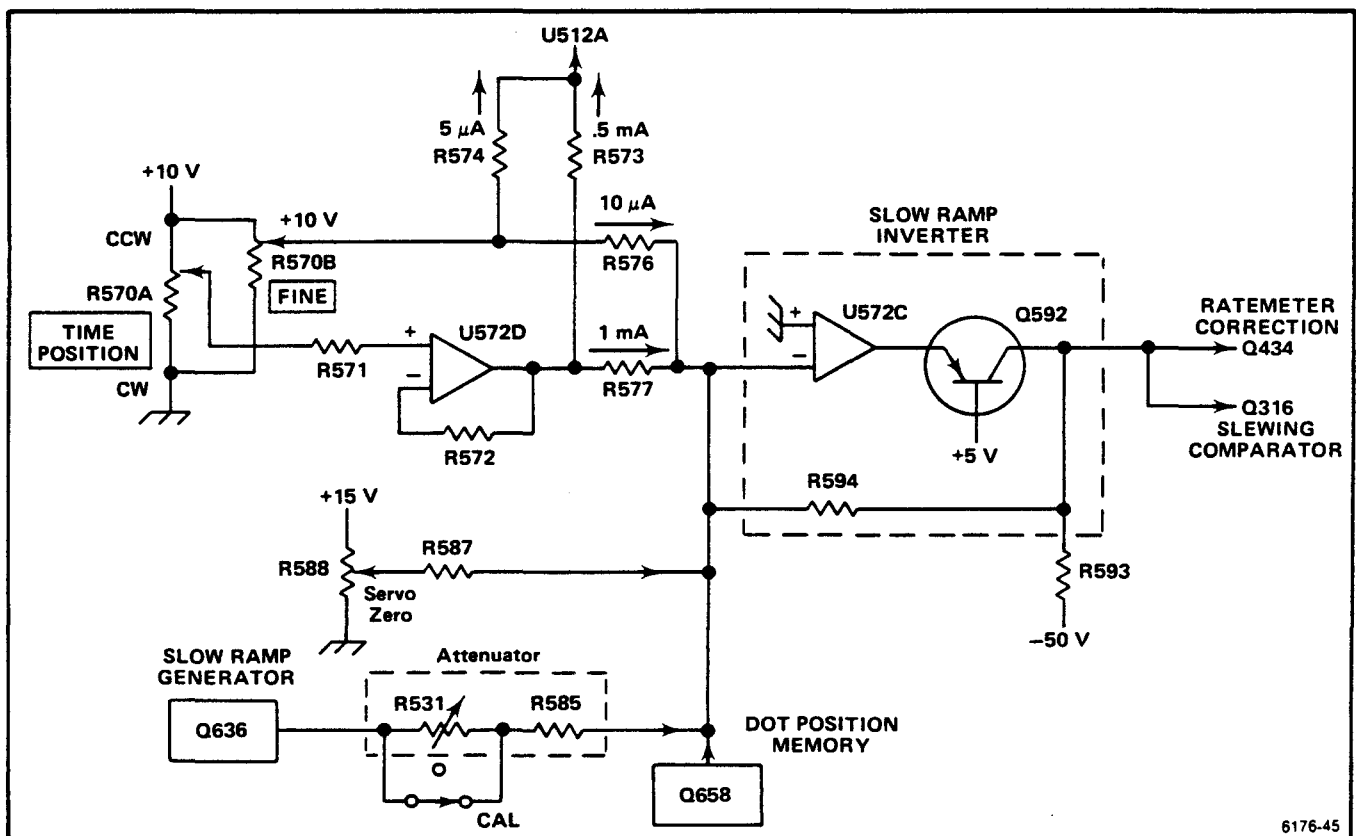

Figure 3-35. Inputs and outputs of the Slow Ramp inverter.

as a high impedance voltage follower. The output voltage of U602 still appears across the SCAN potentiometer R610. Voltage picked off by the moveable contact of the SCAN control is applied to Q616B. The output of Q616 is applied to the base of Q636 and appears at the collector of Q636. This output voltage is fed back to Q616A through the ON resistance of Q620. The X1 gain of the combination of Q616 and Q636 permits use of the SCAN control to set the 7T11A front panel SWEEP CAL adjustment. Since U602 provides an accurate +10 volt source, turning the SCAN through its range will result in 10 divisions of horizontal movement if the SWEEP CAL is properly set.

Operation is the same when EXT SCAN is selected except the SCAN control is now connected to the EXT SCAN INPUT jack.

### Dot Position Memory

As explained in the Circuit Theory portion of this section, a very small voltage at the input of the Horizontal Amplifier can result in a considerable error in the horizontal placement of samples on the CRT. The Dot Position Memory detects errors in the Horizontal Amplifier output by using the Slow Ramp Generator output as a reference.

The 0 volt to +10 volt output of the Slow Ramp Generator is applied across R644, R646, and Dot Position Memory adjustmet R645. The +5 volt to -5 volt output of Output Amplifier U572B is applied across R647, R646 and R645. Resistors R646 and R645 provide an offset to make up for the zero level shift of the memory. With no Output Amplifier error, the positive-going voltage from the Slow Ramp Generator, plus the negative-going voltage from U572B, plus the offset provided by current through R646 and R645 results in 0 volts at the input of the memory (collector of Q652).

Assume a condition that should place a dot horizontally at the center of the CRT. The Slow Ramp Generator output is at +5 volts and when the Slewing Ramp reaches -5 volts Comparator transistor Q316 will fire, stopping the TTH ramp (Diagram 4). The TTH Converter voltage should be -2.5 volts and will appear at the output of the Horizontal Memory as 0 volts. This will place a dot at the horizontal center of the CRT. If a slight voltage error at the Horizontal Amplifier input causes the Output Amplifier voltage to lag, an error voltage will appear at the input of the Dot Position Memory. If the voltage at the output of U572B is +1 volt, instead of the 0 volts that should be present with a slow ramp output voltage of +5 volts, a dot will be placed to the left of graticule center. The result of error in the relationship of these two voltages is a positive error voltage at the collector of Q652.

When the Trigger Output TD (Diagram 2) switches to its low level at 1/2 hold-off interval, a negative-going pulse is applied from the collector of Q184 to the base of Q650. Transistor Q650 turns Q652 and Q654 on, resulting in the error voltage being stored on C654. Resistors R648 and R649 reduce the circuit sensitivity as the gain of the Horizontal Amplifier is increased to prevent overcorrection of dot position error and resultant Dot Position Servo oscillation.

A positive error voltage stored on C654 results in a positive voltage at the output of the Dot Position Memory. The effect of this voltage is to shift negative the reference voltage applied by the Slow Ramp Inverter to the Comparator. The TTH ramp runs longer as a result of the positive error at the input of the Dot Position Memory and the next sample will be positioned closer to its proper position.

If the sample is being displayed to the right of its proper position, a negative error signal appears at the Dot Position Memory input and the TTH ramp will be stopped earlier than normal.

Transistor Q644 is provided to disable gating transistor Q650 during Slow Ramp Retrace.

### Output Amplifier

Two sections (U572A and U572B) of a four-section operational amplifier integrated circuit produce the push-pull signals for the oscilloscope drive. Drive requirements are 0.5 mA/div, push-pull, acting from the center of the screen. Amplifier U572B is a voltage follower with X1 gain and serves to amplify the Horizontal Memory output. Amplifier U572A inverts the information from the memory for the push-pull drive requirement. Both amplifier outputs are used for Overrun blanking drive. The output of U572B is also used during equivalent-time operation for Dot Position Comparator drive. The gain of the output amplifiers is adjusted by shunting some of the amplifier current around the load through front-panel SWEEP CAL control R680. Horizontal positioning is provided by front-panel POSITION control R679.

While the output of U572B is changing from +5 volts to -5 volts, the output of U572A is changing from -5 volts to +5 volts. If the output of either section rises above +5 volts, Blanking Amplifier Q668 turns on Q670 (used for Overrun blanking) thereby preventing a visible display of this portion of the sweep.



## SLOW RAMP INVERTER

A schematic diagram of the Slow Ramp Inverter circuit is given on Diagram 8, in Section 8, Diagrams and Circuit Board Illustrations. The schematic is divided by grey shaded lines separating the circuitry into major stages. These stages aid in locating components mentioned here. Sub-headings in the following discussion use these stage names to further identify portions of the circuitry on Diagram 8.

### General

Two sections of a quad operational amplifier are used for these two amplifiers. The other two sections of this four-section package are used as the Horizontal Output Amplifier. Inputs are delivered to the Slow Ramp Inverter (U572C) from four sources. See Figure 3-35. The four sources are: Time Position Amplifier U572D, Servo Zero adjustment R588, the output of Slow Ramp Generator transistor Q636, and the output of Dot Position Memory transistor Q658 (Diagram 7). The Slow Ramp Inverter delivers an output to two circuits; Ratemeter Correction Memory transistor Q434 (Diagram 5) and Slewing Ramp Comparator transistor Q316 (Diagram 4).

### Time Position Amplifier

The front-panel TIME POSITION control provides a range of voltage from +10 volts (fully CCW) to 0 volts (fully CW) at the input of operational amplifier U572D. The output of Time Position Amplifier U572D simultaneously drives the input of the Horizontal Amplifier (U512A, Diagram 6) and U572C of the Slow Ramp Inverter.

Time position offset current sent through R573 (Diagram 6) effectively delays the TTH Converter output in driving the input of the Horizontal Amplifier below the 0 volt level it requires to produce an output. Time Position current sent through R577 to the Slow Ramp Inverter delays firing of the Slewing Comparator (Diagram 4). With firing of the Comparator delayed, the stopping of the TTH ramp and generation of the strobe pulses that cause sampling of the vertical signal are delayed. The time or display window is therefore delayed with respect to trigger recognition.

With TIME POSITION control R570A set fully CCW, Time Position Amplifier U572D supplies a 1 mA offset current to the input of the Slow Ramp Inverter. The output of Q592 collector is shifted negative, by 5 volts, from the value determined by the other three outputs.

### Slow Ramp Inverter

The output of the Slow Ramp Inverter is fed to the base of Q434 (Diagram 5) and Q316 (Diagram 4). With the reference at the Slewing Ramp Comparator (base of Q316) 5 volts more negative, the Slewing Ramp must run 5 volts more negative to produce a strobe. The first sample and the start of the display window now occur one Time Position Range after  $T_0$ .

The Slow Ramp Inverter output delivered to the base of Q434 is explained in this section under the heading of Ratemeter.

Another input to the Slow Ramp Inverter is delivered through an attenuator from transistor Q636 of the Slow Ramp Generator (Diagram 7). The Slow Ramp Generator output is attenuated by the same factor that the Horizontal Amplifier gain is increased, and is determined by the setting of the TIME/DIV control. Attenuating the Slow Ramp maintains dot density constant as the TIME/DIV control is rotated.

The 20 k $\Omega$  front-panel VARIABLE control is ganged to the VARIABLE control shown at the input to the Horizontal Amplifier and both VARIABLE controls are shorted out in the CAL position. The attenuators at the Slow Ramp Inverter input are shown on Diagram 9, TIMING SWITCHES, set to the position producing zero attenuation. This same condition (TIME/DIV at X1 Mag setting) is represented in Figure 3-35 where only R585 is connected to the Slow Ramp Inverter input. The 0.5 gain (set by ratio or R594 to R585) of the Slow Ramp Inverter results in a positive 5-volt change at the Slow Ramp Generator output appearing as a -2.5 volt change at the Slow Ramp Inverter output.

In addition to the output of Time Position Amplifier U572D and the output of the Slow Ramp Generator, two more inputs are applied to the input of the Slow Ramp Inverter. Dot Position Memory (Diagram 7) is connected through R586 to the input of Slow Ramp Inverter IC U572C. Servo Zero Adjustment R588 is also connected to the input of U572C and sets the output of the Dot Position Memory as near zero as possible.



## TIMING SWITCHES

A schematic diagram of the TIMING SWITCHES and related circuitry is given on Diagram 9, in Section 8, Diagrams and Circuit Board Illustrations. The schematic is divided by grey shaded lines separating the circuitry into major stages.

These stages aid in locating components mentioned here. Sub-headings in the following discussion use these stage names to further identify portions of the circuitry on Diagram 9.

### General

Diagram 9 shows SWEEP RANGE switch S530B and TIME/DIV switch S530A. Twenty cams are provided on each of these switches. Switch S530B does not utilize cams 7, 11, or 12. On both of these switches the cam numbers are determined by considering the cam nearest the instrument front panel to be number 1. The switch actuated by each cam is shown by a dotted line connecting the cam number and the switch.

With the SWEEP RANGE switch turned fully clockwise to its slowest speed setting (5 ms/div to 10  $\mu$ s/div) a reading of 50 ms is indicated in the TIME POS RNG window. Dots are used to indicate which cams close switches at this setting of the Sweep Range switch. Proceeding horizontally from 50 ms shows that cams 17, 15, 9 and 3 are closing their switches.

The TIMING SWITCHES diagram also shows which cams operate switches at each of the nine positions of the TIME/DIV switch. With the Time/Div set fully CCW to the slowest available speed (5 ms/div with the TIME POS RNG window indicating 50 ms) the magnification is X1. At this setting of the TIME/DIV switch, cams 1, 4, 9, 12, 15, 17 and 19 close the switches to which they are connected as shown by dotted lines.

Switches operated by cams of the SWEEP RANGE and TIME/DIV controls are used to produce circuit changes required by different sweep rates and modes of operation. Among changes provided by these switches are changes in hold-off, gain, attenuation, logic, and ramp slope.

### Readout

Readout logic is provided to the oscilloscope readout circuitry by some of the cams of the SWEEP RANGE and TIME/DIV switches. On SWEEP RANGE switch S530B cams 1, 2, 3, and 4 are used. On TIME/DIV switch S530A cams 17, 18, 19 and 20 are used. Another switch (S531C), activated when the front panel VARIABLE (CAL IN) knob is in the out position, also provides readout logic. With S531C closed, a Column current of 0.2 mA and a Row current of 0.1 mA will be provided to the oscilloscope readout circuitry during time slot 3. The symbol for less than (<) will appear on the CRT, just to the left of the time per division readout.

With the SWEEP RANGE switch at its fully clockwise position and the TIME/DIV switch set fully counterclockwise, the CRT readout is 5 ms. Diagram 9, TIMING SWITCHES, shows that the switch controlled by cam 3 of the SWEEP RANGE switch is closed, thereby providing a current path through R745. Switches controlled by cams 17 and 19 of the TIME/DIV switch are also closed, providing current paths through R752 and R755. The effect of closing contact 3 of the SWEEP RANGE switch and contacts 17 and 19 of the TIME/DIV switch can be determined by consulting Table 3-2.

Reference to Table 3-2 indicates that during time-slot 1 closing of contacts 3 and 19 causes the instruction "reduce prefix" to be stored by the oscilloscope readout circuit. Table 3-2 also indicates that during time-slot 4 the number 5 is selected and displayed by the oscilloscope readout.

During time slot 8 Table 3-2 shows that the prefix micro ( $\mu$ ) is selected since neither contact 1 nor 2 is closed. The selected prefix ( $\mu$ ) is not displayed by the readout however, since during time slot 1 the instruction to reduce the prefix was stored. Therefore, the milli (m) symbol is selected and displayed by the oscilloscope readout circuits.

**TABLE 3-2**  
7T11A Readout Switching  
Time Slot 1 (B33)

3 R745 150k	4 R744 75k	19 R752 75k	20 R751 150k	Column Current A37	Row Current B37	Information Stored
					0.2 mA	None
			X	0.1 mA	0.2 mA	Add 1 zero
		X		0.2 mA	0.2 mA	Add 2 zeros
	X			0.2 mA	0.2 mA	Add 2 zeros
X				0.1 mA	0.2 mA	Add 1 zero
	X		X	0.3 mA	0.2 mA	Reduce prefix
X			X	0.2 mA	0.2 mA	Add 2 zeros
	X	X		0.4 mA	0.2 mA	Reduce prefix & add 1 zero
X		X		0.3 mA	0.2 mA	Reduce prefix

Time Slot 4 (A32)

17 R755 37.5k	18 R754 150k	Column Current A37	Row Current B37	Character Selected
		0.2 mA	0.0 mA	1
	X	0.3 mA	0.0 mA	2
X		0.6 mA	0.0 mA	5

Time Slot 8 (A30)

1 R743 150k	2 R747 75k	Column Current A37	Row Current B37	Symbol Selected
		0.2 mA	0.3 mA	$\mu$
X		0.3 mA	0.3 mA	n
	X	0.4 mA	0.3 mA	p

The remaining symbol required to produce a readout of 5 ms is selected during time slot 9. During time slot 9 a Column current of 0.1 mA passes through R741 and a Row current of 0.4 mA passes through R765. These values of current cause the symbol for second (s) to be selected.

For more specific information on the readout circuitry, refer to the instruction manual for your Tektronix 7000-series oscilloscope.



## VOLTAGE DISTRIBUTION & DECOUPLING

A schematic diagram of Voltage Distribution and Decoupling circuits is given on Diagram 11, in Section 8, Diagrams and Circuit Board Illustrations.

### Real-Time and Equivalent-Time Logic

The circuit providing Real-Time and Equivalent-Time Logic consists of diode CR807 and resistor R807. This circuit provides an output voltage of +15 volts if the SWEEP RANGE control is set to an equivalent-time position and an output voltage of -0.6 volts on real-time positions.

The output of the Real-Time/Equivalent-Time Logic circuit is used to enable or disable various circuits when changing from real-time to equivalent-time operation. The notation (+15 V ET, -0.6 V RT) is used on schematics in Section 8, Diagrams and Circuit Board Illustrations, to indicate where the output of the logic circuit is applied.

## SECTION 4 MAINTENANCE

This section of the manual contains information for performing preventive maintenance, corrective maintenance, and troubleshooting for the 7T11A.

### PREVENTIVE MAINTENANCE

Preventive maintenance consists of cleaning, visual inspection, lubrication, etc. Preventive maintenance performed on a regular basis will improve the reliability of this instrument. The severity of the environment to which the 7T11A is subjected determines the frequency of maintenance. A convenient time to perform preventive maintenance is preceding electrical adjustment of the instrument.

#### CLEANING

The side panels of the 7T11A provide protection against dust in the interior of the instrument. Operation without the panels in place necessitates more frequent cleaning.



*Avoid the use of chemical cleaning agents which may damage the plastics used in this instrument. Use a nonresidue type of cleaner, preferably isopropyl alcohol or totally denatured ethyl alcohol. Before using any other type of cleaner, consult your Tektronix Service Center or representative.*

#### Exterior

Loose dust accumulated on the outside of the 7T11A can be removed with a soft cloth or small paint brush. The paint brush is particularly useful for dislodging dirt on and around the front-panel controls. Any remaining dirt can be removed with a soft cloth dampened in a mild detergent and water solution. Abrasive cleaners should not be used.

#### Interior

Dust in the interior of the instrument should be removed occasionally due to its electrical conductivity under high-humidity conditions. The best way to clean the interior is to blow off the accumulated dust with dry, low-pressure air. Remove any remaining dirt with a soft paint brush or a cloth dampened with a mild detergent and water solution. A cotton-dipped applicator is useful for cleaning in narrow spaces on circuit boards.

#### LUBRICATION

The reliability of potentiometers, switches and other moving parts can be maintained if they are kept properly lubricated. However, too much lubrication is as detrimental as too little lubrication. A lubrication kit containing the necessary lubricants and instructions is available from Tektronix, Inc. Order Tektronix Part No. 003-0342-02.

#### VISUAL INSPECTION

The 7T11A should be inspected occasionally for such defects as broken connections, damaged or improperly installed circuit boards, and heat-damaged parts.

The corrective procedure for most visible defects is obvious; however, particular care must be taken if heat damaged components are found. Overheating usually indicates other trouble in the instrument; therefore, it is important that the cause of overheating be corrected to prevent recurrence of the damage.

#### SEMICONDUCTOR CHECKS

Periodic checks of the semiconductors in the 7T11A are not recommended. The best check of semiconductor performance is actual operation in the instrument. More details on semiconductors are given under Troubleshooting later in this section.

#### PERIODIC ELECTRICAL ADJUSTMENT

To ensure accurate measurements, check the electrical adjustment of the 7T11A after each 500 hours of operation or every six months if used infrequently. In addition, replacement of components may necessitate readjustment of the affected circuits. Complete adjustment instructions are given in Section 5, Checks and Adjustment. This procedure can be helpful in localizing certain types of trouble in the instrument, and in some cases, correct them.

# TROUBLESHOOTING

The following information is provided to facilitate troubleshooting of the 7T11A. Information contained in other sections of this manual should be used along with the following information to aid in locating a defective component. An understanding of circuit operation is very helpful in locating trouble. See Section 3, Theory of Operation, for complete information.

## TROUBLESHOOTING AIDS

### Diagrams

Complete schematic diagrams are given on the pullout pages in Section 8, Diagrams and Circuit Board Illustrations. The component circuit number and electrical value of each component in this instrument are shown on these diagrams. Reference designators and symbols used to identify components in this instrument are defined on the first page of Section 8. Important voltages and numbered waveform test points are also shown on the diagrams. Typical waveforms and the numbered test points where they were obtained are located adjacent to each diagram. Portions of circuits located on circuit boards are enclosed with heavy black lines on the diagrams.

### Circuit Board Illustrations

To aid in locating circuit boards, an illustration showing circuit board location within the 7T11A appears beside each circuit board illustration in Section 8. The circuit board illustrations are located on the rear of pullout pages and are used to identify the physical location of components and waveform test points that appear on the respective schematic diagrams. Each circuit board illustration is arranged within a grid and has a locator index for rapid location of components contained in the corresponding schematic diagrams.

### Adjustment and Test Point Locations

To aid in locating test points and adjustable components referred to in various sections of this manual, an Adjustment and Test Point Locations foldout page is provided in Section 8.

### Static-Sensitive Device Classification



*Static discharge can damage any semiconductor component in this instrument.*

This instrument contains electrical components that are susceptible to damage from static discharge. See Table 4-1 for relative susceptibility of various classes of semiconductors. Static voltages of 1 kV to 30 kV are common in unprotected environments.

**TABLE 4-1**  
Relative Susceptibility to Damage  
from Static Discharge

Semiconductor Class	Relative Susceptibility Level <sup>1</sup>
MOS or CMOS microcircuits and discrete or linear microcircuits with MOS inputs (most sensitive).	1
ECL	2
Schottky signal diodes	3
Schottky TTL	4
High-frequency bipolar transistors	5
JFET's	6
Linear microcircuits	7
Low-power Schottky TTL	8
TTL (least sensitive)	9

<sup>1</sup>Voltage equivalent for susceptibility levels. (Voltage discharged from a 100 pF capacitor through a resistance of 100  $\Omega$ ).

1 = 100 to 500 V	6 = 600 to 800 V
2 = 200 to 500 V	7 = 400 to 1000 V
3 = 250 V	8 = 900 V
4 = 500 V	9 = 1200 V
5 = 400 to 600 V	

Observe the following precautions to avoid damage:

1. Minimize handling of static-sensitive components.



2. Transport and store static-sensitive components or assemblies in their original containers on a metal rail or conductive foam. Label any package that contains static-sensitive assemblies or components.

3. Discharge the static voltage from your body by wearing a wrist strap while handling these components. Servicing static-sensitive assemblies or components should be performed only at a static free work station by qualified service personnel. We recommend use of the Static Control Mat, Tektronix Part No. 006-3414-00, and Wrist Strap, Tektronix Part No. 006-3415-00.

4. Allow nothing capable of generating or holding a static charge on the work station surface.

5. Keep the component leads shorted together whenever possible.

6. Pick up components by the body, never by the leads.

7. Do not slide the components over any surface.

8. Avoid handling components in areas that have a floor or work-surface covering capable of generating a static charge.

9. Use a soldering iron that is connected to earth ground.

10. Use only special antistatic suction-type desoldering tools.

### Wiring Color Code

All insulated wire and cable used in the 7T11A is color coded to facilitate circuit tracing. Table 4-2 gives the wiring color code used in the 7T11A.

**TABLE 4-2**  
**Power Supply Wire Color Code**

Supply	Color Code
+ 50 V	Orange/Red
+ 15 V	Brown/Red
+ 5 V	Black/Red
- 15 V	Black/Violet
- 50 V	Brown/Violet

### Resistor Color Code

In addition to composition resistors, some metal-film resistors are used in the 7T11A. The resistance values of composition resistors and metal-film resistors are color coded on the components with EIA color code (some metal-film resistors may have the value printed on the body). The color code is read starting with the stripe nearest the end of the resistor. Composition resistors have four stripes that consist of two significant figures, a multiplier and a tolerance value (see Figure 4-1). Metal-film resistors have five stripes consisting of three significant figures, a multiplier and a tolerance value.

### Capacitor Marking

The capacitance values of common disc capacitors and small electrolytics are marked in microfarads on the side of the component body. The white ceramic capacitors used in the 7T11A are color coded in picofarads using a modified EIA code (see Figure 4-1).

### Diodes

The cathode end of each glass-encased diode is indicated by a stripe, a series of stripes, or a dot. The cathode and anode ends of metal-encased diodes can be identified by the diode symbol marked on the body.

### Semiconductor Lead Configuration

Figure 4-2 shows the lead configuration for semiconductor devices used in this instrument.

### Multi-Pin Connector Identification

Multi-pin connectors mate with groups of pins soldered to circuit boards. Pin number 1 is indexed with a triangular mark etched on the circuit board and molded on the holder of the multi-pin connector, as shown in Figure 4-3. Each group of pins is identified by its corresponding P number etched on the circuit board. The J and P numbers on the circuit boards correlate to the J and P circuit numbers on schematic diagrams.

### Interface Connector Pin Locations

The Interface circuit board couples the plug-in unit to the associated oscilloscope mainframe. Figure 4-4 identifies the pins on the Interface connector as shown in Section 8 on Diagram 10.

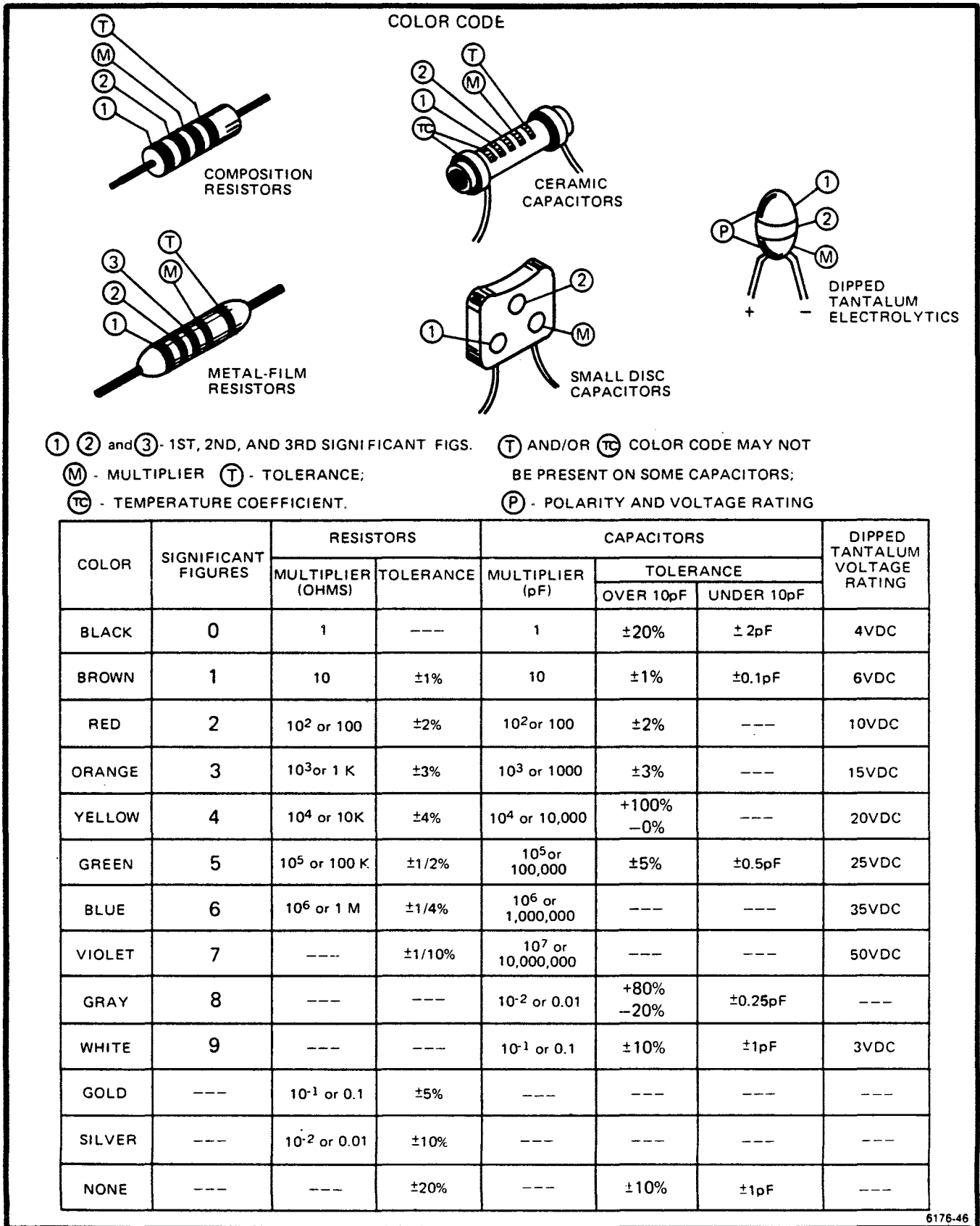
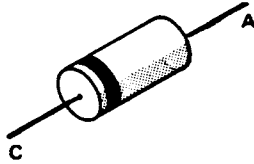

Figure 4-1. Resistor and capacitor color code.

6176-46

**NOTE**  
LEAD CONFIGURATIONS AND CASE STYLES ARE TYPICAL, BUT MAY VARY DUE TO VENDOR CHANGES OR INSTRUMENT MODIFICATIONS.



SIGNAL DIODE

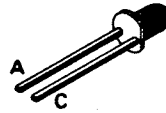

LIGHT EMITTING DIODE (L.E.D.)

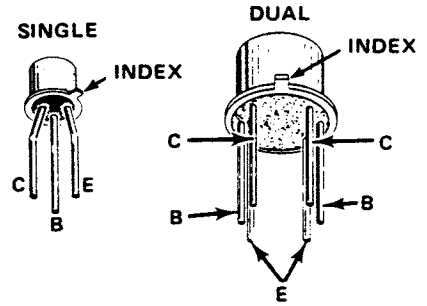

METAL CASE TRANSISTORS

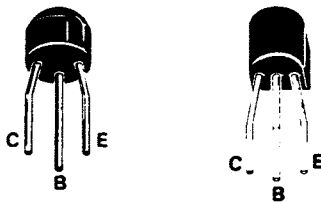

PLASTIC CASE TRANSISTORS

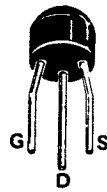

PLASTIC CASE FETS

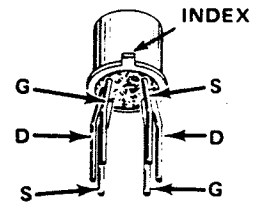

DUAL METAL CASE FET

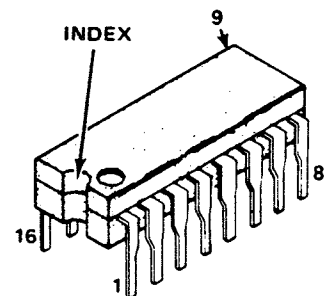
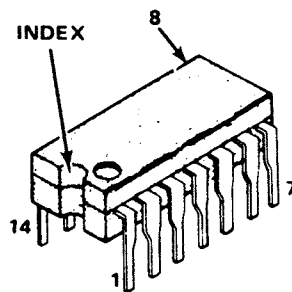
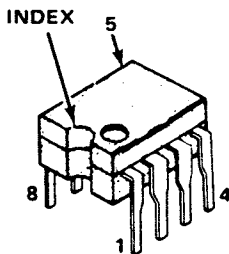

INTEGRATED CIRCUITS

6176-47

Figure 4-2. Semiconductor lead configuration.

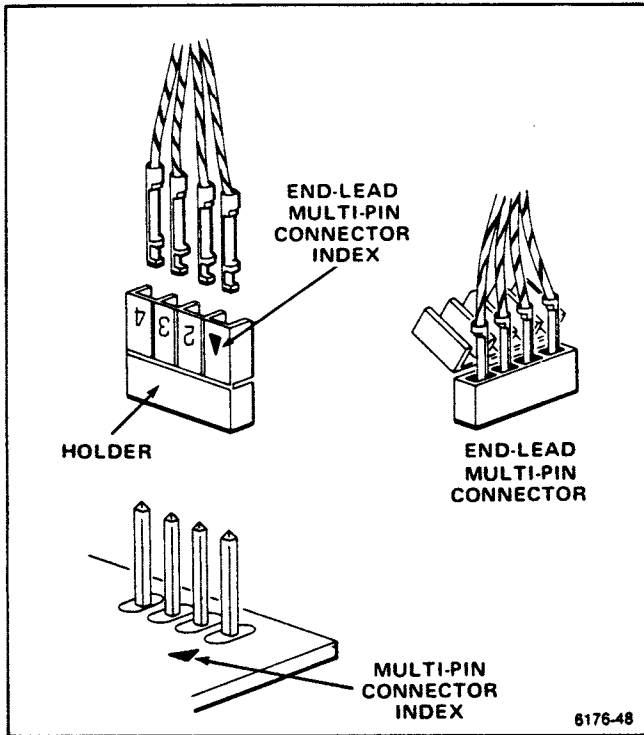

Figure 4-3. Orientation of multi-pin connectors.

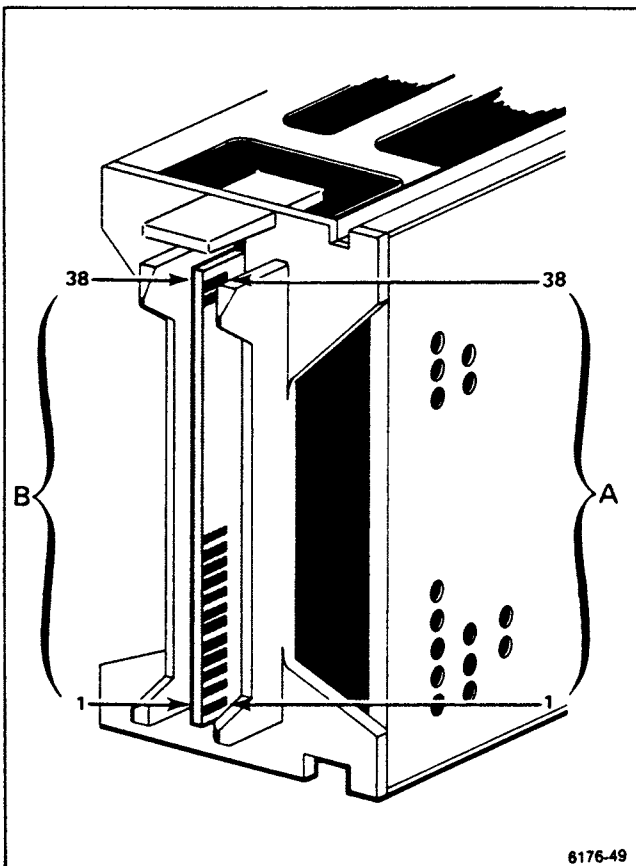

Figure 4-4. Pin numbering on interface connector.

## TROUBLESHOOTING TECHNIQUES

This troubleshooting procedure is arranged in an order that checks the simple trouble possibilities before proceeding with extensive troubleshooting. The first few checks assure proper connection, operation, and adjustment. If the trouble is located by these checks, the remaining steps aid in locating the defective component. When the defective component is located, replace it using the replacement procedure given under Component Replacement in this section.

### 1. Check Control Settings

Incorrect control settings can simulate a problem that does not exist. If there is any question about the correct function or operation of any control, see Section 2, Operating Instructions.

### 2. Check Associated Equipment

Before proceeding with troubleshooting of the 7T11A, check that the indicator oscilloscope and equipment used with this instrument are operating correctly. Check that the signal is properly connected and that the interconnecting cables are not defective. Also check the line-voltage source.

### 3. Visual Check

Visually check the portion of the instrument in which the trouble is located. Many problems can be located by visual indications such as unsoldered connections, broken wires, damaged circuit boards, damaged components, etc.

### 4. Check Instrument Adjustment

Check the electrical adjustment of the instrument, or of the affected circuit if the trouble appears in one circuit. The apparent trouble may only be a result of misadjustment. Complete adjustment instructions are given in Section 5, Checks and Adjustment.

### 5. Isolate Trouble to a Circuit

To isolate trouble to a particular circuit, note the trouble symptom. The symptom often identifies the circuit in which the trouble is located. When trouble symptoms appear in more than one circuit, check affected circuits by taking voltage and waveform readings. Also check for the correct output signals at the front-panel output connectors with a test oscilloscope. If the signal is correct, the circuit is working correctly up to that point.

## 6. Check Voltage and Waveforms

Often the defective component can be located by checking for the correct voltage or waveform in the circuit. Typical voltages and waveforms are given on the diagrams pullout pages in Section 8.

### NOTE

*Voltages and waveforms given on the diagrams are not absolute and may vary slightly between instruments. To obtain operating conditions similar to those used to take these readings, see the Voltage and Waveform Test Conditions pullout page in Section 8.*

## 7. Check Individual Components

The following procedures describe methods of checking individual components in the 7T11A. Components that are soldered in place are best checked by first disconnecting one end. This isolates the measurement from the effects of surrounding circuitry.

### WARNING

*To avoid electric shock and possible damage to the instrument, Remove the 7T11A from the oscilloscope mainframe before removing or replacing semiconductors.*

**Transistors.** A good indication of transistor operation is its actual performance under operating conditions. A suspect transistor can most effectively be checked by substituting one that has been checked previously. However, be sure that circuit conditions are not such that a replacement transistor might also be damaged. If substitute transistors are not available, use a dynamic tester. Static-type testers are not recommended, since they do not check operation under simulated operating conditions.

**Integrated Circuits.** Integrated circuits can be checked with a voltmeter, test oscilloscope, or by direct substitution. A good understanding of circuit operation is essential for troubleshooting circuits that use integrated circuits. In addition, operating waveforms, logic levels, and other operating information for integrated circuits are given in Section 3, Theory of Operation. Use care when checking voltages and waveforms around the integrated circuits so that adjacent leads are not shorted together. Use proper tools while removing or inserting integrated circuits. An integrated circuit test clip provides a convenient means of clipping a test probe to the 14- and 16-pin integrated circuits. The clip also doubles as an integrated circuit extraction tool.

**Diodes.** A diode can be checked for an open or shorted condition by measuring the resistance between terminals with an ohmmeter. The diode resistance should be very high in one direction and very low when the meter leads are reversed. Do not check tunnel diodes or zener diodes with an ohmmeter.

### CAUTION

*Do not use an ohmmeter scale that has a high internal current. High currents may damage the diode.*

**Resistors.** Check resistors with an ohmmeter. See Section 7, Replaceable Electrical Parts List, for the tolerance of resistors used in this instrument. Resistors normally do not need to be replaced unless the measured value varies widely from the specified value.

**Inductors.** Checking for continuity with an ohmmeter can identify open inductors. Shorted or partially shorted inductors can usually be identified by checking the waveform response when high-frequency signals are passed through the circuit. Partial shorting often reduces high-frequency response (causes roll-off).

**Capacitors.** A leaky or shorted capacitor can best be detected by checking resistance with an ohmmeter set to the highest scale. Do not exceed the voltage rating of the capacitor. The resistance reading should be high after initial charge of the capacitor. An open capacitor can best be detected with a capacitance meter or by checking if the capacitor passes AC signals.

## 8. Repair and Readjust the Circuit

If any defective parts are located, follow the replacement procedures given under Component Replacement in this section. Be sure to check the performance of any circuit that has been repaired or has had any electrical components replaced.

## TROUBLESHOOTING PROCEDURE

If the 7T11A is operating well except for certain settings of one or two controls, then troubleshooting can usually be limited to the areas affecting the operation of the unit for these settings. In event of extensive failure, the procedure outlined below can sometimes facilitate repairs.



*The oscilloscope mainframe Power switch must be turned off before removing or replacing the plug-in.*

Remove the 7T11A from the oscilloscope mainframe and check the power supply buses (including the 10-volt reference bus) for shorts to ground. Turn off the power to the oscilloscope mainframe and connect the 7T11A to the oscilloscope via an extender plug-in (Calibration Fixture, Tektronix Part No. 067-0589-00). Connect A2J344 (7T11A) and J430 (Sampling Drive and Oscillator Control) from the Sampling Unit in the adjacent vertical compartment) using a Special RF Cable Assembly (Tektronix Part No. 012-0203-00).

Turn the power on.

**1. Check power supply voltages**, including the 10-volt reference supply provided by A2U602.

**2. Check the trigger selection circuit** for proper operation.

**3. Check reed switch drive coils** for applied voltage (+5 V) when the actuating button is pushed.

**4. Check reed switch actuation** with an ohmmeter.

### 5. Check the Trigger Source switch:

INT	Voltage to INT coil A3K32: +5 V
EXT 50 $\Omega$	Voltage to EXT 50 $\Omega$ coil A3K31: +5 V
EXT 1 M $\Omega$	Voltage to EXT 1 M $\Omega$ coil A3K30: +5 V
HF SYNC	Voltage to all coils: 0 V. Slope and Trig Amp lights out.
All buttons up	Voltage to EXT 50 $\Omega$ coil A3K31: +5 V

### 6. Check the Trigger Amp switch:

X1	No coil voltage, A3Q82 input connected to gnd.
X10	Voltage to X10 coil A3K80: +5 V. A3Q82 input connected to the trig line.

### 7. Check the Trigger Slope switch:

+	Voltage to + coil A3K71: +5 V
-	Voltage to - coil A3K70: +5 V

**8. Check operation of the 1 M $\Omega$  Amplifier** and set 1 M Zero adjustment A3R45 for zero input-output differential with zero signal input.

**9. Check operation of the X10 Amplifier.** Measure from the junction of A3CR95 and A3CR96 to ground. Output should be zero when X10 pushbutton is actuated (use 50  $\Omega$ , external source, zero signal). Output should drop to approximately -0.5 volts in the X1 position.

**10. Check the Schmitt Trigger circuit for operation.** Set the STABILITY control full counterclockwise. Voltage at varistor light bulb A3DS136 should be zero. Set the STABILITY control full clockwise. Voltage at the varistor light bulb should be about 4 volts. The Schmitt Trigger circuit should not free run at any setting of the TRIG LEVEL control with the STABILITY control full counterclockwise.

**11. Check Trig Level Zero.** Set the STABILITY control for free running within a narrow band. The Schmitt Trigger circuit should still free run within this narrow band when + or - slope is selected.

**12. Check the TRIG LEVEL indicator dot position** to be 2 o'clock when Trig Level Zero is properly adjusted. For this check use 50  $\Omega$ , ext trig input, zero signal.

**13. Check Arming Bias and Output Bias adjustments** A3R145 and A3R155 are to be set for triggered operation. Use the Pulse Generator recommended for use in Section 5.

**14. Check the Holdoff Multivibrator;** it should now run. Check for operation in all equivalent-time (sequential) position ranges.

**15. Check for operation of the following circuits** with the Holdoff Multivibrator running. Set TIME POSITION RANGE to 5  $\mu$ s and refer to waveforms shown on the schematics in Section 8 of this manual.

a. Pulse Out Driver—When this circuit is functioning, the test scope can be triggered by this pulse.

b. Trigger Coupling Amplifiers.

c. Start Multivibrator.

d. Slewing Ramp—It may be necessary to unplug one end of 510  $\Omega$  resistor A1R586. Set TIME/DIV to .1  $\mu$ s and TIME POSITION to midrange.

e. Time Position Amplifier (A1U572D).

f. Slow Ramp Generator.

g. Slewing Ramp Comparator—the collector of A2Q328 should change from -15 V to about +3 volts in 2 ns.

h. Strobe Drivers—To get an output, return the collector of A2Q342 to ground through a resistor (100  $\Omega$  to 1 k).

i. Stop Drive to (-) Slope Driver (input of A2Q252).

j. Time to Height Converter.

k. Horizontal Amplifier.

l. Horizontal Memory Gate Driver.

m. Horizontal Memory—Memory Gate Bal adjustment A2R550 may now be set.

n. Output Amplifiers.

o. Dot Position Memory—Once the output amplifiers have been checked, reconnect the 510  $\Omega$  resistor.

**16. Check Time To Height Converter output.** Switch sampling mode from Sequential to Random. Set TIME POSITION RANGE to 5  $\mu$ s or 50  $\mu$ s. Set the TIME POSITION control full counterclockwise. Use the test oscilloscope and monitor the Time To Height Converter output. The plateau between the start multivibrator firing and the trigger input should be flat, with no + or - slope.

If the unit does not work properly in Random mode, check the Ratemeter and the Ratemeter Correction Memory for correct operation.

**17. Check for operation in Real Time sampling mode.** If not functional in the .5  $\mu$ s TIME POSITION RANGE, check the Real Time Multivibrator and feedback reset path through A2Q554 to the Holdoff Multivibrator.

# CORRECTIVE MAINTENANCE

Corrective maintenance consists of component replacement and instrument repair. Special techniques required to replace components in the 7T11A are given here.

## OBTAINING REPLACEMENT PARTS

### Standard Parts

All replaceable electrical and mechanical parts for the 7T11A can be obtained through your local Tektronix Field Office or representative. Before purchasing or ordering replacement parts, check the parts list for value, tolerance, rating, and description.

#### NOTE

*When selecting replacement parts, it is important to remember that the physical size and shape of a component may affect its performance in the instrument, particularly at high frequencies. All replacement parts should be direct replacements unless it is known that a different component will not adversely affect instrument performance.*

### Special Parts

In addition to standard electronic components, some special components are used in the 7T11A. These components are manufactured or selected by Tektronix, Inc. to meet specific performance requirements, or are manufactured for Tektronix, Inc. in accordance with our specifications. Most of the mechanical parts used in this instrument have been manufactured by Tektronix, Inc. To determine the manufacturer of parts, refer to the cross index, Manufacturer Code Number to Manufacturer, at the beginning of Section 7, Replaceable Electrical Parts List, and Section 9, Replaceable Mechanical Parts List. Order all special parts directly from your local Tektronix Field Office or representative.

### Ordering Parts

When ordering replacement parts from Tektronix, Inc. include the following information:

1. Instrument type.
2. Instrument serial number.

3. A description of the part (if electrical, include the circuit number).

4. Tektronix Part number.

## SOLDERING TECHNIQUES

### WARNING

*To avoid electric shock and possible damage to the instrument, Remove the 7T11A from the oscilloscope mainframe before soldering.*

### Circuit Boards

Use the procedures given under Component Replacement to remove the boards from the instrument before soldering. General soldering techniques that apply to maintenance of any precision electronic equipment should be used on this instrument. Use only 60/40 resin-core, electrical-grade solder and a 15- to 20-watt pencil type soldering iron on the circuit boards. The tip of the iron should be clean and properly tinned for best heat transfer to the solder joint. A higher wattage soldering iron may separate the etched circuit wire from the board base material.

The following technique should be used to replace a component on a circuit board.

1. Grip the component lead with long-nose pliers. Touch the soldering iron to the lead at the solder connections. Do not lay the iron directly on the board as it may damage the board.



2. When the solder begins to melt, pull the lead out gently. This should leave a clean hole in the board. If not, poke a sharp object such as a toothpick into the hole to clean it out. A vacuum-type desoldering tool can also be used for this purpose.

3. Bend the leads of the new component to fit the holes in the board. Insert the leads into the holes in the boards so the component is firmly seated against the board, or as positioned originally. If it does not seat properly, heat the solder and gently press the component into place.

4. Touch the iron to the connection and apply a small amount of solder to make a firm solder joint; do not apply more solder than is necessary for a good electrical connection. To protect heat-sensitive components, hold the lead between the component body and the solder joint with a pair of long-nose pliers or other heat sink.

5. Clip any excess component lead that protrudes through the board.

6. Clean the area around the solder connection with a flux-remover solvent. Be careful not to remove information printed on the board.

### Metal Terminals

When soldering metal terminals (e.g., potentiometers, etc.), use 60/40 resin-core, electrical-grade solder. Use a soldering iron with a 40- to 75-watt rating and a 1/8-inch wide wedge-shaped tip.

Observe the following precautions when soldering metal terminals:

1. Apply only enough heat to make the solder flow freely. Use a heat sink to protect heat-sensitive components.

2. Apply only enough solder to form a solid connection. Excess solder may impair the function of the part.

3. If a wire extends beyond the solder joint, clip off the excess.

4. Clean the flux from the solder joint with a flux-removing solvent.

## COMPONENT REPLACEMENT

### WARNING

*To avoid electric shock and possible damage to the instrument, remove the 7T11A from the oscilloscope mainframe before replacing components.*

The exploded-view drawing associated with the Replaceable Mechanical Parts List in Section 9 may be helpful in the removal or disassembly of individual components or sub-assemblies.

### Circuit Board Replacement

If a circuit board is damaged beyond repair, the entire assembly, including all soldered-on components, can be replaced. Part numbers are given in Section 7, Replaceable Electrical Parts List, for the completely wired board. Use the following procedure to remove the plug-on circuit boards.

1. Disconnect any pin connectors located on the front of the board.

2. Loosen all of the securing screws on the board.

3. Pull out the edges of the board until the board clears the chassis terminals. Attempt to lift the board away from the chassis in such a way that it remains parallel to the chassis at all times so as not to bend the interconnecting terminals.

4. To replace a plug-on circuit board, position it so the securing screw holders mate with the guide posts on the chassis.

5. Gently press the circuit board against the chassis. Be sure that all of the interconnecting pins and sockets have properly mated.

6. Uniformly tighten the securing screws. Recommended torque is four to six inch-pounds.

### Circuit Board Pin Replacement

It is important not to damage or disturb the ferrule when removing the old stub of a broken pin. The ferrule is pressed into the circuit board and provides a base for soldering the pin connector (see Figure 4-5). If the broken stub is long enough, grasp it with a pair of long-nose pliers, and apply heat with a small soldering iron to the pin base or the ferrule so a firm pull is required to pull it out. If the broken stub is too short to grasp with pliers, use a small dowel (0.028 inches in diameter) clamped in a vise to push the pin out of the ferrule after the solder has been heated. The old ferrule can be cleaned by reheating the solder and placing a sharp object such as a toothpick or small dowel into the hole. A vacuum-type solder removing tool is also useful for removing excess solder. Use a pair of diagonal cutters to remove the ferrule from the new pin, then insert the pin into the old ferrule, and solder the pin to both sides of the ferrule. If it is necessary to bend the new pin, grasp the base of the pin with long-nose pliers and bend against the pressure of the pliers to avoid breaking the board around the ferrule.

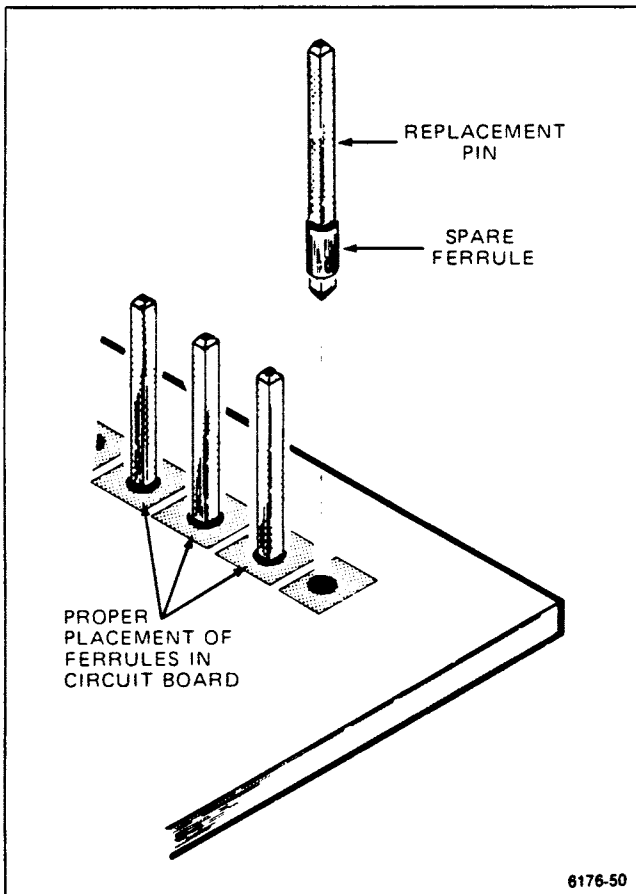

Figure 4-5. Exploded view of circuit-board pin and ferrule.

### Circuit Board Pin Socket Replacement

The pin sockets on the circuit boards are soldered to the rear of the board. To replace one of these sockets, first unsolder the pin (use a vacuum-type desoldering tool to remove excess solder). Then straighten the tabs on the socket and remove it from the hole in the circuit board. Place the new socket in the circuit board hole and press the tabs down against the board. Solder the tabs of the socket to the circuit board; be careful not to get solder into the socket.

#### NOTE

*The spring tension of the pin sockets ensures a good connection between the circuit board and the pin. This spring tension can be destroyed by using the pin sockets as a connecting point for spring-loaded probe tips, alligator clips, etc.*

### End-Lead Pin Connector Replacement

The pin connectors used to connect wires to the interconnecting pins are clamped to the ends of the associated leads. To replace damaged end-lead pin connectors, remove the old pin connector from the end of the lead and clamp the replacement connector to the lead.

### Coaxial End-Lead Connector Replacement (RF and Peltola Connectors)

Replacement of coaxial-type end-lead connectors requires special tools and techniques. We recommend that the cable be replaced as a unit. For cable part numbers, see the Replaceable Mechanical Parts List in Section 9. An alternative solution is to refer the replacement of the defective connector to your local Tektronix Field Office or representative.

### Multiple End-Lead Connector Replacement

Some of the pin connectors are grouped together and mounted in a plastic holder; the overall result is that these connectors are removed and installed as a multi-pin connector (see Figure 4-3). To provide correct orientation of this multi-pin connector when it is replaced, an arrow is etched on the circuit board and a matching arrow is molded into the plastic holder of the connector. These arrows must be aligned as the multi-pin connector is replaced. If the individual end-pin connectors are removed from the plastic holder, note the color of the individual wires for replacement.

### Tunnel Diode A3CR28 Replacement

Locate the clip shown in Figure 4-6 on Trigger Board assembly A3. Leadless capacitor C27 and tunnel diode CR28 are located under this clip. Figure 4-6 shows that one side of C27 is soldered to the 50  $\Omega$  stripline. A 0.3 inch length of 3/1000 inch diameter wire, serving as inductor L27, is connected from the 50  $\Omega$  stripline to relay K31. Be careful not to disturb this wire when replacing CR28, since the fine wire is easily broken.

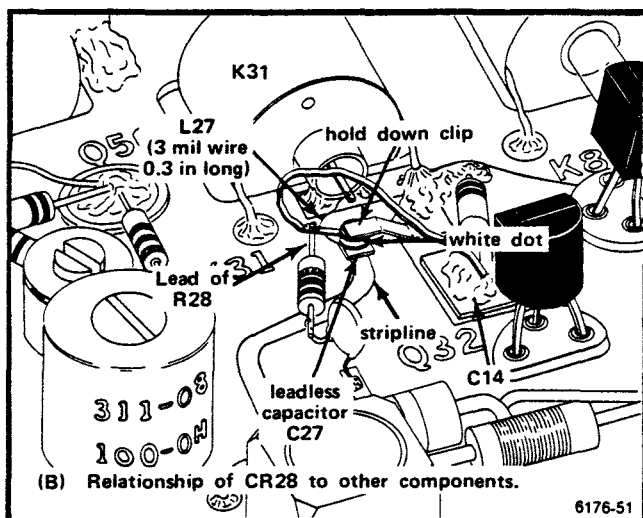

Figure 4-6. Location of 200 MHz oscillator tunnel diode (A3CR28).

Tunnel diode CR28 is positioned between C27 and the hold-down clip. The clip, together with the support provided by the lead of resistor R28, holds the tunnel diode in place. The lead from the anode of CR28 is formed into a loop (shown as L23 on the Trigger Input schematic in Section 8) and the lead end is soldered to leadless capacitor C14.

Carefully unsolder the tunnel diode lead from C14 using a 15-watt soldering iron and a pair of tweezers. Next unsolder R28 and C28. Use tweezers to carefully remove the tunnel diode from underneath the clip. Protect CR28 with a heat sink and unsolder R28 from the tunnel diode lead.

Determine the cathode side of the new tunnel diode before soldering R28 to the tunnel diode lead. The cathode is indicated by a white dot (see Figure 4-6). Clip off the lead connected to the tunnel diode cathode. Heat sink the tunnel diode and solder R28 to the tunnel diode anode lead. Carefully slip the tunnel diode under the hold down clip with the cathode side up. Resolder R28 to C28 and solder the extreme end of the tunnel diode lead to C14.

The free-run frequency of the 200 MHz oscillator is increased as more of the tunnel diode lead length is soldered to C14. The shape of the loop formed by the tunnel diode lead also has some effect on the oscillator frequency.

Set HF Sync adjustment R10 to the minimum bias current setting providing a stable display at all settings of the STABILITY control. Reducing the tunnel diode bias current increases the oscillator frequency range. Adjustment of R10 is explained in detail in Section 5 of this manual.

The frequency change provided by the STABILITY and TRIG LEVEL controls must be at least the amount shown in Figure 4-7. If the oscillator frequency is 220 MHz with the STABILITY and TRIG LEVEL controls fully counterclockwise, an oscillator frequency range of at least 55 MHz is required to ensure countdown on all frequencies from 1 GHz to 12.4 GHz. Turning the STABILITY and TRIG LEVEL controls fully clockwise (in this example) must result in an oscillator frequency of 275 MHz or higher.

If the minimum oscillator frequency (controls counterclockwise) is 250 MHz or higher, a large oscillator frequency range is required. To ensure that oscillator frequency range requirements are met, it is recommended that the minimum oscillator frequency (STABILITY and TRIG LEVEL counterclockwise) be 245 MHz or lower. As previously mentioned, lengthening the unsoldered portion of the tunnel diode lead (CR28) will reduce the oscillator frequency.

### Switch Replacement

Two types of switches, pushbutton and cam, are used in the 7T11A. Either type should be replaced as a unit if damaged. Special maintenance information for each type is provided below.



*Repair of the cam switch should only be undertaken by skilled maintenance personnel. Switch alignment and contact spacing must be carefully maintained for proper operation of the switch. The cam switch repair kit contains special alignment tools for use in repairing or replacing the cam and contacts. For information or assistance on maintenance of the cam switch, contact your local Tektronix Field Office or representative.*

**Cam Switch.** The cam switch (TIME/DIV and SWEEP RANGE) consists of a rotating cam, which is turned by the front panel knob, and a set of contacts mounted on an adjacent circuit board. These switch contacts are actuated by lobes on the cam. The switch can be disassembled for inspection, cleaning, repair, or replacement as follows:

1. Remove the two screws holding the metal covers on each of the two switch sections. The front switch section is the TIME/DIV switch and the rear switch section is the SWEEP RANGE switch. The covers can now be removed to clean or inspect the switch contacts.

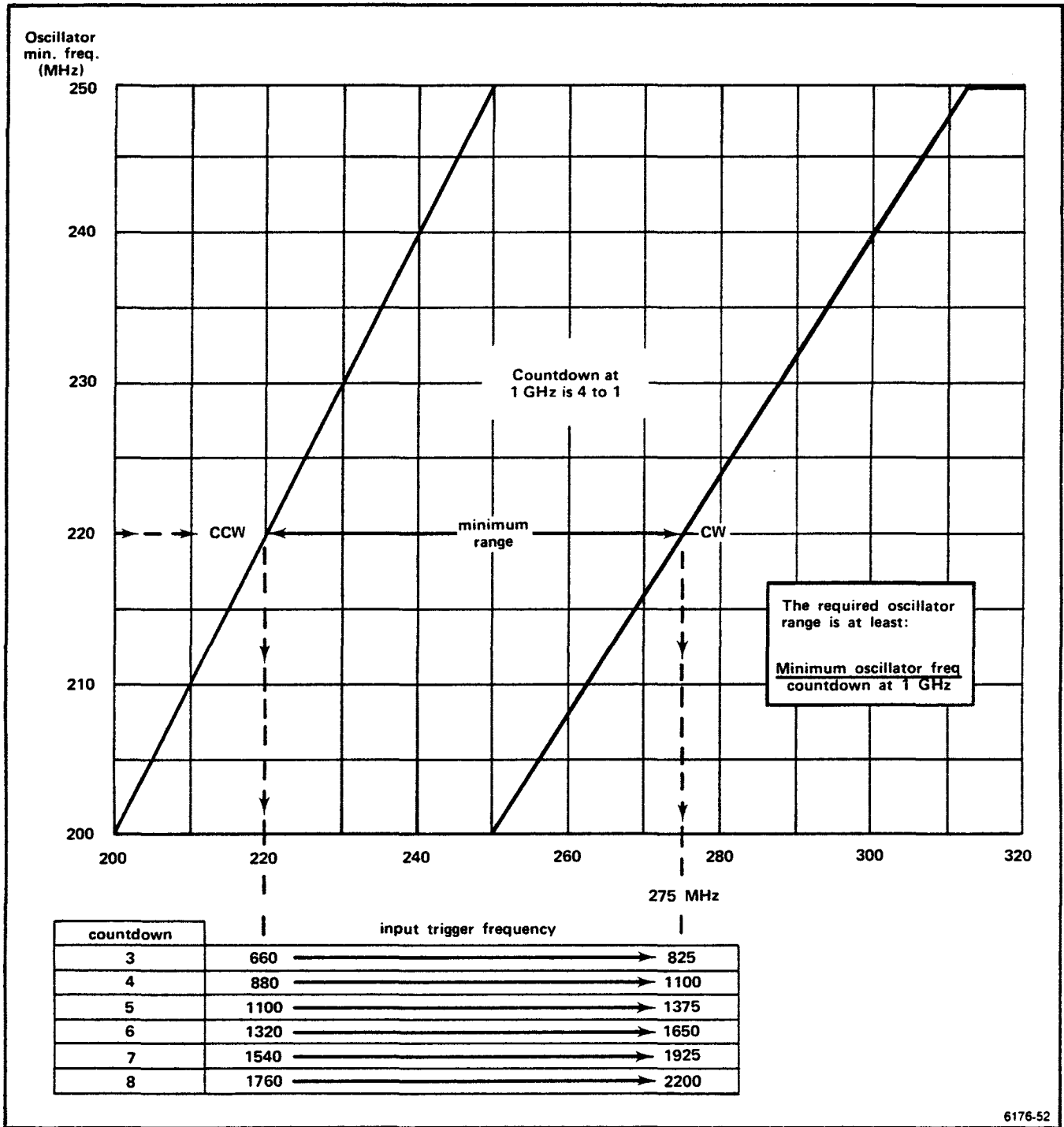

6176-52

Figure 4-7. Minimum range required for the 200 MHz oscillator.

2. To completely remove either of the switch sections from the board, loosen the hex-socket screws (use a 0.035-inch hex-key wrench) in the shaft at the front of the rear switch section and a hex-socket screw (use a 0.050-inch hex-key wrench) at the rear of the rear switch. Pull both long shafts out of the switch assembly.

3. The rear section can be removed by removing the four screws that hold the cam switch to the circuit board (from the rear side of board).

4. The front section can be removed by first removing the remaining knob (use a 1/16-inch hex-key wrench) and nut holding the switch shaft to the front panel. Remove the four screws that hold the cam switch to the circuit board (from the rear side of board).

5. To remove the cam from the front support block, remove the retaining ring from the shaft on the front of the switch and slide the cam out of the support block. Be careful not to lose the small detent roller.

6. To replace defective switch contacts, first unsolder the damaged contact and clean the solder from the hole in the circuit board. Then, position the new contact in the hole so it is properly aligned in relation to the other switch contacts and the mating area on the circuit board (alignment tool provided in switch repair kit). Finally, solder the new contact into place; be sure that the spring end of the contact has adequate clearance from the circuit board.

7. To re-install the switch assembly, reverse the above procedure.

**Pushbutton Switches.** Use the following procedure to replace any of the pushbutton switches.

1. Loosen the set screws and remove all front panel knobs.

2. Remove any other nut or part holding the front panel to the instrument.

3. Remove the front panel to gain access to the switch mounting screws.

4. To remove any of the pushbutton switches, first remove the screws securing the switch to the front panel. Unsolder and remove any wire connected to the switch circuit board and carefully note where it belongs. See Figure 4-8.

## Lamp Replacement

To replace a lamp in one of the pushbutton switch assemblies, follow the above procedure to remove the affected switch. Remove the screw and cover from the back of the switch to expose the lamp. Unsolder the two leads and remove the lamp. Cut the leads of the replacement lamp to the same length as those of the old lamp. Place insulated sleeves over the leads and replace the new lamp in the exact position of the old lamp.

Reassemble by reversing the above procedure.

## ADJUSTMENT AFTER REPAIR

After any electrical component has been replaced, the adjustment of that particular circuit or any closely related circuits should be checked. See Section 5, Checks and Adjustment for complete performance check and adjustment procedures.

## REPACKAGING FOR SHIPMENT

### NOTE

*The plug-in should not be shipped in an oscilloscope. The oscilloscope packaging material is not designed to protect the plug-ins.*

If the Tektronix instrument is to be shipped to a Tektronix Service Center for service or repair, attach a tag showing: owner (with address), the name of an individual at your firm that can be contacted, complete instrument serial number, and a description of the service required.

Save and re-use the package in which your instrument was shipped. If the original packaging is unfit for use or not available, repackage the instrument as follows:

Surround the instrument with polyethylene sheeting to protect the finish of the instrument. Obtain a carton of corrugated cardboard of the correct carton strength and having inside dimensions of no less than six inches more than the instrument dimensions. Cushion the instrument by tightly packing three inches of dunnage or urethane foam between carton and instrument, on all sides. Seal carton with shipping tape or industrial stapler.

The carton test strength for your instrument is 200 pounds.

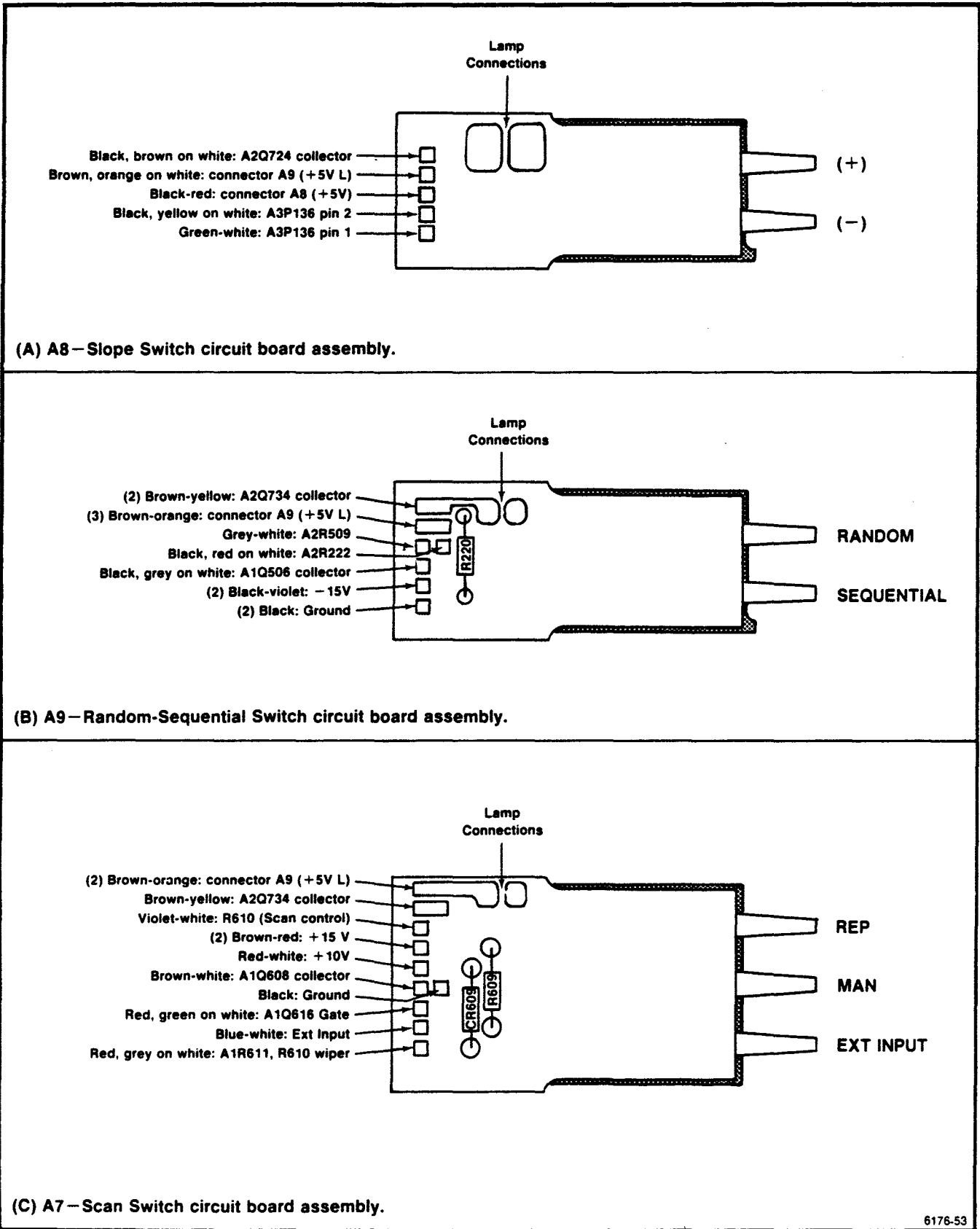

6176-53

Figure 4-8. Connections to switch assemblies.

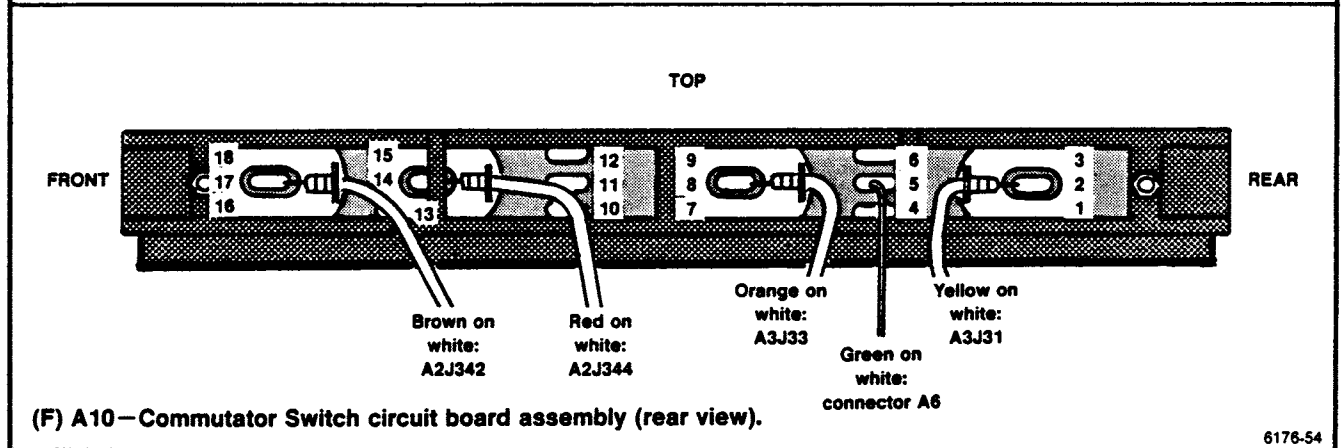
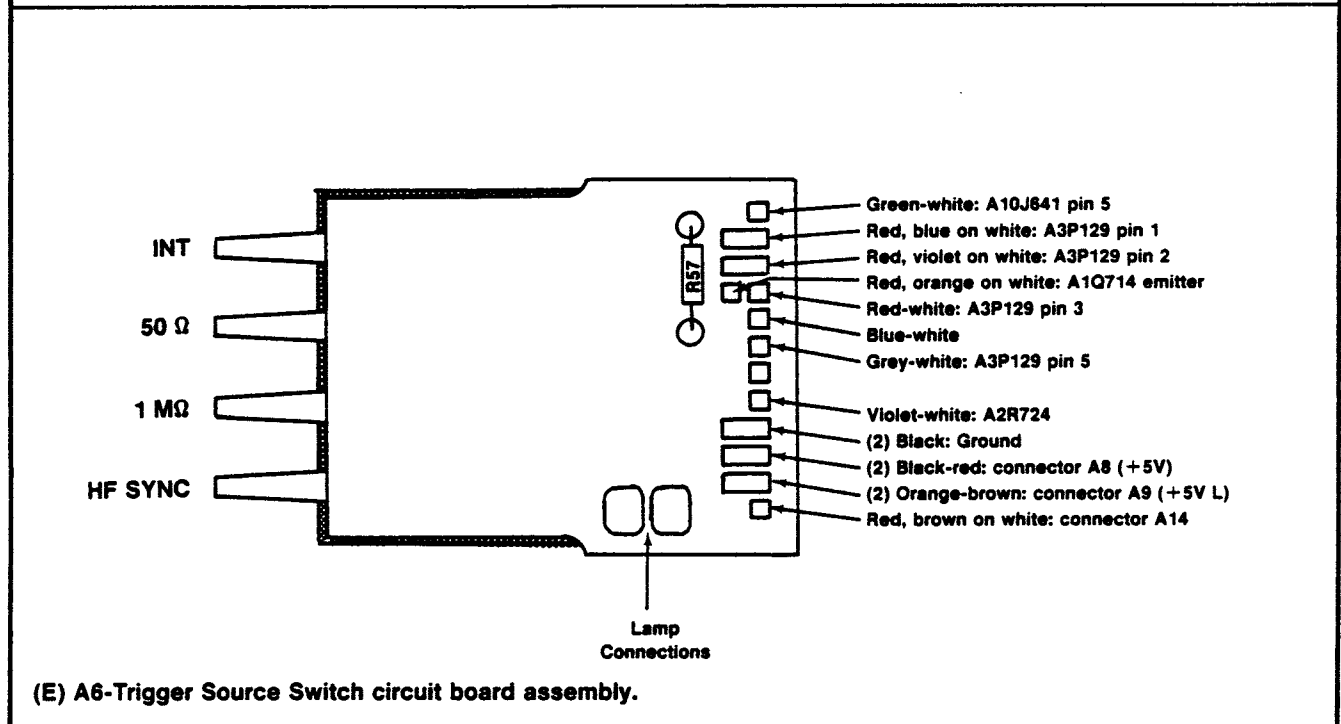
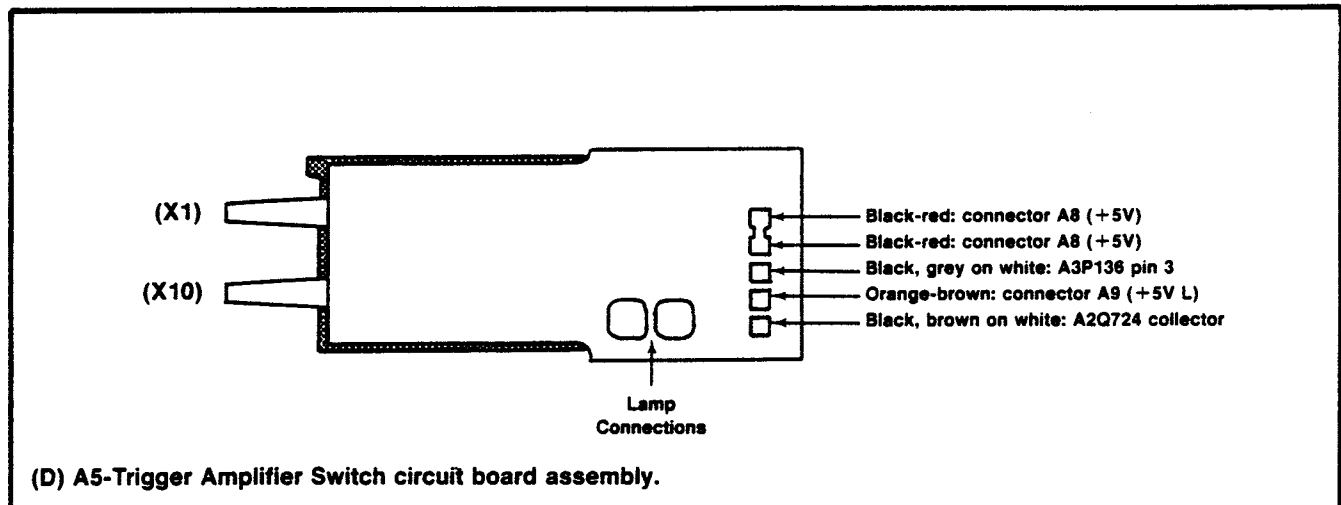

6176-54

Figure 4-8. Connections to switch assemblies (cont.).

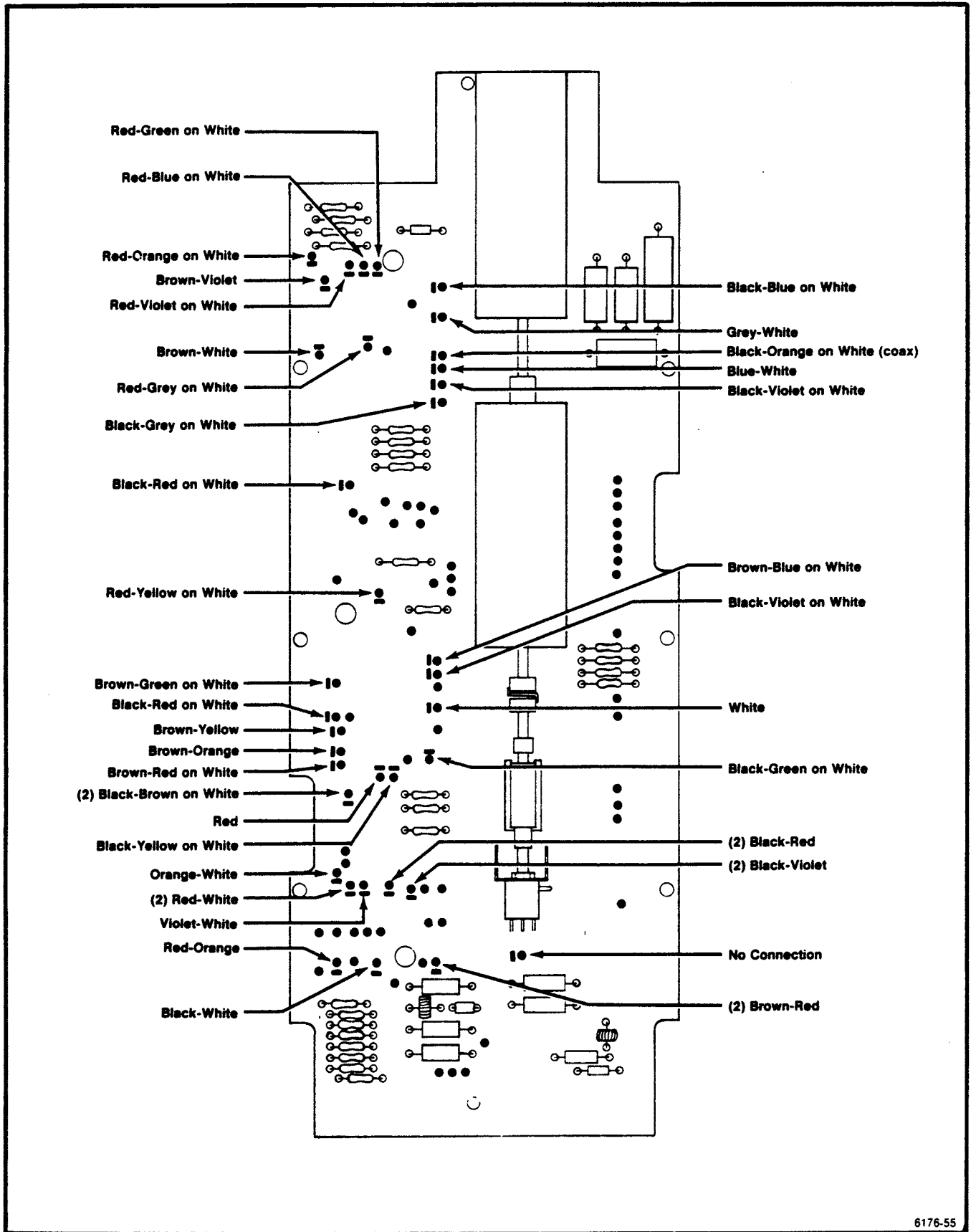

6176-55

Figure 4-9. Connections to interface assembly A4.



## SECTION 5 CHECKS AND ADJUSTMENT

This section provides information necessary to: (1) verify that the instrument meets applicable electrical specifications in Section 1, (2) verify that controls function properly, and (3) perform all internal adjustments.

The Part I—Performance Check procedure checks the electrical specifications listed in Section 1 with out making any internal adjustments.

The Part II—Performance Check and Adjustment procedure provides a complete sequential check of instrument performance concurrent with a complete sequential adjustment of internal controls.

A separate Operators Checkout Procedure is provided in Section 2 of this manual for familiarization with the instrument and to verify that all front-panel controls and connectors function properly.

### PRELIMINARY INFORMATION

#### Using These Procedures

Both Part I—Performance Check and Part II—Performance Check and Adjustment are divided into functional block subsections (e.g., A. TRIGGER ADJUSTMENTS, B. SCAN AND TIMING, etc.) The order in which the subsections and steps (A1, A2, B1, B2, etc.) appear in each procedure is the recommended sequence for accomplishing a performance check or adjustment of the instrument. Subsections within either procedure can be performed independently, as can each step within any subsection. Refer to Partial Procedures for specific instructions on performing either a partial Performance Check or partial Performance Check and Adjustment.

All functional block subsections begin with a list of required test equipment, followed by instructions for Before You Begin and the list of Preliminary Control Settings for that subsection (e.g., A1. TRIGGER ADJUSTMENTS PRELIMINARY CONTROL SETTINGS). Each step contains separate Setup Conditions which, if applicable, include the instrument control settings, an illustrated test setup, and test equipment control settings. The instrument and test equipment control settings listed in the Setup Conditions for each step may include additional settings, changes from the previous step, or changes to the Preliminary Control Settings making it possible to perform partial procedures. The illustrated test setup in the Setup Conditions shows all test equipment needed to perform the entire step, as well as the setup necessary to begin the step instructions.

In this procedure, capital letters within the body of text identify front-panel controls, indicators and connectors on the 7T11A (e.g., SCAN). Initial capital letters identify controls, indicators, and connectors (e.g., Position) on associated test equipment used in this procedure. Initial capitals also identify adjustments inside the 7T11A (e.g., Memory Gate Bal).

A heading system is provided to readily identify the steps (A1, A2, B1, B2, etc.) that contain performance check and/or adjustment instructions. For example, if CHECK is the first word in the title of a step, an electrical specification is checked. If ADJUST is the first word in the title, the step concerns one or more internal adjustments. If CHECK/ADJUST appears in the title, the step involves electrical specification checks and related adjustments. If EXAMINE is the first word in the step title, the step concerns measurement limits that indicate whether the instrument is operating properly; these limits are not to be interpreted as electrical specifications.

The alphabetical instructions under each step (a, b, c, etc.) may also contain CHECK, EXAMINE, ADJUST, or INTERACTION as the first word of the instruction. These terms are defined as follows:

1. **ADJUST**—describes which adjustment to make and the desired result. We recommend that the adjustments not be made if a previous CHECK or EXAMINE instruction indicates that no adjustment is necessary.

2. **CHECK**—indicates that the instruction accomplishes an electrical specification check. Each electrical specification checked is listed in Table 5-1, Performance Check Summary (see Performance Check Summary discussion for more information).

3. **EXAMINE**—usually precedes an ADJUST instruction and indicates that the instruction determines whether adjustment is necessary. If no ADJUST instruction appears in the same step, the EXAMINE instruction concerns measurement limits that have no related adjustment. Measurement limits following the word EXAMINE are not to be interpreted as electrical specifications. They are provided as indicators of a properly functioning instrument and to aid in the adjustment process.

4. **INTERACTION**—indicates that the adjustment described in the preceding instruction interacts with other circuits. The nature of the interaction is described and reference is made to the step(s) affected.

### Partial Procedures

**Part I—Performance Check.** To perform a partial Performance Check procedure, first determine which electrical specifications are to be checked. Table 5-1, Performance Check Summary, lists the performance characteristics specified in Section 1 and provides references to the step(s) in which the performance requirements are checked. The Performance Check Index, at the start of Part I—Performance Check, provides a convenient means for locating the desired subsections and steps. For example, if a circuit within the instrument has been repaired and a performance check is considered necessary, use the Performance Check Summary table to locate the specifications affected by the repair and the step title of Part I—Performance Check in which those performance requirements are checked. Then use the Performance Check Index to locate the procedure subsection and the step and page number of the applicable step(s).

Any step of a subsection can be performed separately by following the instructions given below.

1. Locate the desired subsection and applicable steps (e.g., B1, B2, etc.) with the Performance Check Summary table and the Performance Check Index.

2. Perform the Performance Check Power Up Sequence at the start of Part I—Performance Check and the instructions under Before You Begin and Preliminary Control Settings at the beginning of the subsection.

3. Perform the Setup Conditions instructions for the desired step. Disregard any control settings which are the same as those under Preliminary Control Settings.

4. Proceed with the lettered instructions (e.g., a, b, c, etc.).

### NOTE

*If the steps performed are consecutive, it is not necessary to repeat the Preliminary Control Settings after the first step. However, when a step is skipped, the Preliminary Control Settings must be performed again.*

**Part II—Performance Check and Adjustment.** Although each step in Part II—Performance Check and Adjustment can be performed independently, we recommend that the entire subsection be performed if any adjustments are made. Table 5-1, Performance Check Summary, lists the performance characteristics specified in Section 1 and provides references to the step(s) in which the performance requirements are checked and appropriate adjustments made. The Performance Check and Adjustment Index at the start of Part II provides a convenient means for locating the desired subsections and steps. For example, if a circuit board has been repaired or replaced, use the Performance Check Summary table to locate the specifications affected by the repair, and the step title(s) of Part II—Performance Check and Adjustment in which those performance requirements are checked and adjusted. Then use the Performance Check and Adjustment Index to locate the appropriate subsection, step, and page number.

### Performance Check Summary

Table 5-1, Performance Check Summary, lists the performance characteristics specified in Section 1 and checked in this section. Table 5-1 is intended to provide a convenient means for locating the procedures that check and/or adjust the instrument to meet the applicable electrical specifications. Steps containing internal adjustments that affect a performance characteristic are indicated by an asterisk in Table 5-1. Steps with adjustments that may indirectly affect the electrical specification are also given. For example, if the A3 Trigger Board has been repaired, use Table 5-1 to locate the performance characteristics affected by the repair or replacement. Then note the title of the procedure(s) in which those specifications are checked and/or adjusted. Use the index provided at the front of the procedure to find the page number of the desired procedure step(s).

**TABLE 5-1**  
**Performance Check Summary**

Steps containing adjustments are indicated by an asterisk.

<b>Characteristic</b>	<b>Part I— Performance Check Steps</b>	<b>Part II— Performance Check and Adjustment Steps</b>
Time/Div		
Timing	A2	B6*,B7*
Variable	A2	B6*
Triggering Sensitivity and Frequency Range		
Internal	B2, B3, B4	A2*, A3*, A4*, A5, A6*, C2, C3, C4
External 50 $\Omega$	B2, B3, B4	A2*, A3*, A4*, A5, A6*, C2, C3, C4
External 1 M $\Omega$	B2, B3	A2*, A3*, A4*, A5, A6*, C2, C3
HF Sync	B4, B5	A4*, A5, B10*, B11*, C4, C5
Display Jitter		
50 $\Omega$ and 1 M $\Omega$		
Sequential Mode	B6, B8	C6, C8, C10
Random Mode	B7, B8	C7, C8, C10
HF Sync (Random or Sequential)	B9	C9, C10
Pulse Out		
Amplitude	B10	C11
Risetime	B10	C11
Trigger Kickout	B11	C11
Minimum Trigger Rate in Random Mode	B12	A2*, A3*, A4*, A5, A6*, C15
Scan Rate (Repetitive)	A3	B2*, B3*, B5*, B8
Sweep Cal	A2	B6*
External Input Deflection Factor	A5	B2*, B3*, B5*, B6*, B12
Sweep Out Voltage	A4	B2*, B3*, B5*, B9

## Checks and Adjustment—7T11A

### Adjustment Interval

To maintain instrument accuracy, check performance every 500 hours of operation, or every 6 months if used infrequently. Before complete adjustment, thoroughly clean and inspect the 7T11A as outlined in Section 4, Maintenance.

### Tektronix Field Service

Tektronix Field Service Centers and the Factory Service Center provide instrument repair and adjustment services. Contact your Tektronix Field Office or representative for further information.

### Special Fixtures

Special Fixtures are used only where they facilitate instrument adjustment and no suitable alternative is known. These fixtures are available from Tektronix Field Offices or representatives.

### Test Equipment Alternatives

All the listed test equipment is required to completely check and adjust the 7T11A. However, complete checking or adjusting may not always be necessary or desirable. You may be satisfied with checking selected characteristics only, thereby reducing the amount of test equipment actually required.

## TEST EQUIPMENT REQUIRED

The test equipment listed in Table 5-2 is required for a complete Performance Check and Adjustment of the 7T11A. The specifications for test equipment, given in Table 5-2, are the minimum required to verify Performance Requirements. Detailed operating instructions for test equipment are omitted in these procedures. Refer to the test equipment instruction manual if more information is needed.

If only a Performance Check is to be performed, the items required for Adjustment are not required and are indicated in Table 5-2 by footnote 1. The remaining test equipment is common to both procedures.

The procedures are based on the first item of equipment given as an example. When other equipment is substituted, control settings or setups may have to be altered. If the exact item of equipment given as an example in Table 5-2 is not available, first check the Minimum Specifications column carefully to see if any other equipment might suffice. Then check the Purpose column to see where this item is used. If used for a performance check or adjustment that is of little or no importance for your measurement requirements, the item and corresponding step(s) can be deleted. Cables and adapters listed in Table 5-2 and shown in Setup Conditions illustrations are those recommended for use with the applicable test equipment given in Table 5-2. Use of alternate test equipment may require additional or different cables and adapters than those shown.

**TABLE 5-2**  
**Test Equipment**

Description	Minimum Specifications	Purpose	Examples of Applicable Test Equipment
1. Oscilloscope Mainframe	Tektronix 7000-Series; 250 MHz bandwidth; four plug-in compartments.	Provides display for test equipment and unit under test.	Tektronix 7704A.
2. Sampling Unit	Tektronix 7000-Series; compatible with S-Series Sampling Heads and 7T11A.	Accepts Sampling Head and interconnects with 7T11A to provide vertical portion of sampling system.	Tektronix 7S11.
3. Sampling Head	Tektronix S-Series; 50 $\Omega$ input impedance; internal trigger pickoff; 2 mV or less noise for checking trigger kickout.	Provides vertical signal input and internal trigger pickoff to the Sampling Unit.	Tektronix S-1 for checking trigger kickout. Tektronix S-4 for all other applications.
4. Time Mark Generator	50 ms to 1 ns; at least 200 mV output amplitude into 50 $\Omega$ ; accuracy within 1.5%.	Provides timing reference for verification of unit under test.	Tektronix TG 501.
5. Differential Comparator Plug-In	Tektronix 7000-Series; 1 mV/Div to 5 V/Div deflection factor; 0 to 10 V + or -0.1%; 1 M $\Omega$ input impedance.	Provides vertical input to the oscilloscope mainframe and internal voltage reference for comparator measurements.	Tektronix 7A13.
6. Time Base Plug-In	Tektronix 7B-Series.	Provides horizontal sweep on Oscilloscope Mainframe for Differential Comparator display.	Tektronix 7B50A.
7. Low Frequency Sine Wave Generator	50 Hz to 350 kHz frequency range; 0 to 5 V variable output amplitude.	Provides signal source for checking trigger operation.	Tektronix SG 502.
8. Medium Frequency Sine Wave Generator	350 kHz to 250 MHz frequency range; 0 to 5 V variable output amplitude.	Provides signal source for checking trigger operation.	Tektronix SG 503.
9. High Frequency Sine Wave Generator	500 MHz to 1 GHz frequency range; 0.5 to 4 V variable output amplitude.	Provides signal source for checking trigger operation.	Tektronix SG 504.
10. Pulse Generator	70 ps or less risetime; 1 $\mu$ s or more pulse width; at least 200 mV signal amplitude into 50 $\Omega$ .	Provides signal for trigger adjustments and display jitter checks.	Tektronix 284.
11. 50 $\Omega$ Delay Line	50 $\Omega$ impedance; 75 ns delay; 150 ps risetime.	Used as a signal delay to check display jitter.	Tektronix 7M11.

**TABLE 5-2 (cont)**  
**Test Equipment**

Description	Minimum Specifications	Purpose	Examples of Applicable Test Equipment
12. SHF Signal Generator	12.4 GHz; 200 - 500 mV variable output voltage.	Signal source for checking HF SYNC triggering.	Hewlett Packard 626A.
13. Calibration Fixture, Plug-In Extender <sup>1</sup>	Tektronix 7000-Series.	Provides access to internal connections and adjustments in the unit under test.	Tektronix Part No. 067-0589-00.
14. Special RF Cable Assembly <sup>1</sup>	36-inches long with coaxial connectors.	Provides signal interconnection between the Sampling Unit and unit under test.	Tektronix Part No. 012-0203-00.
15. 1X Probe	Compatible with 1 M $\Omega$ inputs.	Provides signal input to Differential Comparator for trigger adjustments.	Tektronix P6101A.
16. 10X Probe <sup>1</sup>	Compatible with 1 M $\Omega$ inputs; 10X attenuation.	Provides signal input to Differential Comparator for trigger adjustments.	Tektronix P6105A.
17. SMA to BNC Adapter (two required, one provided with 7T11A)	SMA male and BNC female connectors.	Provides signal interconnection to Sampling Head and unit under test.	Tektronix Part No. 015-1018-00.
18. SMA to GR Adapter (provided with 7T11A)	SMA male and GR874 connectors.	Provides signal interconnection between GR type cables and the unit under test.	Tektronix Part No. 015-1007-00.
19. GR to BNC Adapter (four required)	GR874 and female BNC connectors.	Signal interconnection for checking display jitter.	Tektronix Part No. 017-0063-00.
20. 50 $\Omega$ BNC Termination <sup>1</sup>	50 $\Omega$ feed through with BNC connectors.	Provides connector termination on the unit under test for external trigger adjustment.	Tektronix Part No. 011-0049-01.
21. 5X BNC Attenuator	50 $\Omega$ ; 5X (14 dB) attenuation; BNC connectors.	Provides signal attenuation for external trigger checks and adjustment.	Tektronix Part No. 011-0060-02.
22. 10X BNC Attenuator (provided with 7T11A)	50 $\Omega$ ; 10X (20 dB) attenuation; BNC connectors.	Provides signal attenuation for external trigger checks.	Tektronix Part No. 011-0059-02.
23. 2X SMA Attenuator	50 $\Omega$ , feed through type, female and male SMA connectors.	Signal attenuation for checking HF Sync triggering.	Tektronix Part No. 015-1001-00.
24. BNC T Connector	One male and two female BNC connections.	Provides dual signal path for checking external triggers.	Tektronix Part No. 103-0030-00.

<sup>1</sup> Required only for adjustment.

**TABLE 5-2 (cont)**  
**Test Equipment**

Description	Minimum Specifications	Purpose	Examples of Applicable Test Equipment
25. GR Power Divider	GR connectors; 50 $\Omega$ tee impedance when two legs are terminated in 50 $\Omega$ .	Provides dual signal path when checking external triggers and display jitter.	Tektronix Part No. 017-0082-00.
26. SMA Power Divider	50 $\Omega$ impedance; vswr less than 1.9 at 12.4 GHz; nominal 2X voltage attenuation; male SMA connectors.	Signal splitting for checking HF Sync triggering.	Tektronix Part No. 015-1014-00.
27. 18-Inch, 50 $\Omega$ BNC Cable (two required)	50 $\Omega$ ; 18 inches long; BNC connectors.	Provides signal interconnection between test equipment and unit under test.	Tektronix Part No. 012-0076-00.
28. 50 $\Omega$ BNC Cable (provided with 7T11A)	50 Ohms; 42 inches long; BNC connectors.	Provides signal interconnection between test equipment and unit under test.	Tektronix Part No. 012-0057-01.
29. BSM to BNC Cable	Coaxial; 10 inches long; female BSM and male BNC connectors.	Provides signal interconnection between Sampling Unit and unit under test for checking Pulse Out operation.	Tektronix Part No. 012-0128-00.
30. 50 $\Omega$ SMA Cable (two required)	2 ns delay, male and female SMA connectors.	Signal interconnection for checking HF Sync Triggering.	Tektronix Part No. 015-1005-00.
31. Patch Cord	two pin-jack connectors.	Interconnection of Sampling Unit and unit under test for checking EXT INPUT.	Tektronix Part No. 012-0179-00.
32. Low Capacitance Screwdriver <sup>1</sup>	2-inch shaft with 3/32p-inch bit.	Adjustment of variable capacitors and resistors.	Tektronix Part No. 003-0675-00.
33. Wrench <sup>1</sup>	5/16-inch open end.	Removal and replacement of front-panel EXT TRIG INPUT connector for adjustment procedure.	Tektronix Part No. 003-0260-00.
34. Screwdriver <sup>1</sup>	Pozidrive with #1 point.	Removal and replacement of Trigger Board for adjustment procedure.	Tektronix Part No. 003-0616-00.
35. GR T Connector	Three GR connectors.	Signal splitting for checking display jitter.	Tektronix Part No. 017-0069-00.

<sup>1</sup> Required only for adjustment.

## PART I—PERFORMANCE CHECK

The following procedure (Part I—Performance Check) verifies electrical specifications in Section 1 without making any internal adjustments.

Part II—Performance Check and Adjustment provides the information necessary to (1) verify that the instrument meets the applicable electrical specifications, (2) verify that all controls function properly, and (3) perform all internal adjustments.

A separate Operators Checkout Procedure is provided in Section 2 of this manual for familiarization with the instrument and to verify that all front-panel controls and connectors function properly. See Preliminary Information, at the beginning of this section, on performing a partial Performance Check procedure.

### PERFORMANCE CHECK INDEX

PAGE

#### A. SCAN AND TIMING

A1. SCAN AND TIMING PRELIMINARY CONTROL SETTINGS .....	5-9
A2. CHECK TIMING .....	5-10
A3. CHECK REPETITIVE SCAN RATE .....	5-12
A4. CHECK SWEEP OUT RANGE .....	5-13
A5. CHECK EXT INPUT .....	5-13

#### B. TRIGGERING

B1. TRIGGERING PRELIMINARY CONTROL SETTINGS .....	5-14
B2. CHECK LOW-FREQUENCY TRIGGERING ..	5-15
B3. CHECK MEDIUM-FREQUENCY TRIGGERING .....	5-15
B4. CHECK HIGH-FREQUENCY TRIGGERING ..	5-17
B5. CHECK 12.4 GHz HF SYNC TRIGGERING ..	5-17
B6. CHECK SEQUENTIAL-MODE DISPLAY JITTER AT FASTEST SWEEP RANGE POSITION .....	5-18
B7. CHECK RANDOM-MODE DISPLAY JITTER AT FASTEST SWEEP RANGE POSITION .....	5-19
B8. CHECK DISPLAY JITTER AT REMAINING SWEEP RANGE POSITIONS .....	5-20
B9. CHECK HF SYNC DISPLAY JITTER .....	5-21
B10. CHECK PULSE OUT INTO 50 Ω .....	5-21
B11. CHECK TRIGGER KICK OUT .....	5-22
B12. CHECK MINIMUM TRIGGER RATE IN RANDOM MODE .....	5-23

### PERFORMANCE CHECK POWER UP SEQUENCE

*NOTE*

*7T11A performance can be checked at an ambient temperature from 0° C to +50° C unless otherwise stated. Adjustments must be performed at an ambient temperature from +20° C to +30° C for specified accuracies.*

1. Install a Differential Comparator Plug-In unit in the left vertical compartment and a Time Base Plug-In unit in the B horizontal compartment of the Oscilloscope Mainframe.

2. Install the Sampling Unit (with the Sampling Head installed) in the right vertical compartment of the Oscilloscope Mainframe and the 7T11A in the A horizontal compartment.

3. Set the mainframe Intensity controls to minimum. Turn on the mainframe and allow at least 20 minutes warmup before beginning the procedure.



## A. SCAN AND TIMING

### Equipment Required:

- |                                     |                                    |
|-------------------------------------|------------------------------------|
| 1. Oscilloscope Mainframe           | 7. 1X Probe.                       |
| 2. Sampling Unit.                   | 8. 18-Inch BNC Cable (2 required)  |
| 3. Sampling Head.                   | 9. SMA to BNC Adapter (2 required) |
| 4. Time Mark Generator              | 10. BNC T Connector                |
| 5. Differential Comparator Plug-In. | 11. Patch Cord                     |
| 6. Time Base Plug-In.               |                                    |

### BEFORE YOU BEGIN:

(1) Perform the Performance Check Power Up Sequence.

(2) Refer to section 6, Instrument Options, and the Change Information section at the rear of this manual for any modifications that may affect this procedure.

(3) See the **TEST POINT AND ADJUSTMENT LOCATIONS** foldout page in section 8, Diagrams and Circuit Board Illustrations.

### NOTE

*The 7T11A SWEEP RANGE control and TIME POS RNG display window are integral features. In this procedure, SWEEP RANGE settings are indicated by the value appearing in the TIME POS RNG window.*

### A1. SCAN AND TIMING PRELIMINARY CONTROL SETTINGS:

7T11A

TIME POSITION .....	Fully clockwise
FINE .....	Fully clockwise
SLOPE .....	(-)
TRIG LEVEL .....	Midrange
STABILITY .....	Fully clockwise
SEQUENTIAL Pushbutton .....	Pressed in
SWEEP RANGE .....	50 $\mu$ s
TIME/DIV .....	5 $\mu$ s
VAR .....	CAL
REP Pushbutton .....	Pressed in
SCAN .....	Midrange

Sampling Unit

DC Offset .....	Midrange
Units/Div .....	100

Oscilloscope Mainframe

Vertical Mode .....	Right
Horizontal Mode .....	A

**Checks and Adjustment—7T11A**  
**Part I—Performance Check**

**A2. CHECK TIMING**

**NOTE**

First perform step A1, then proceed.

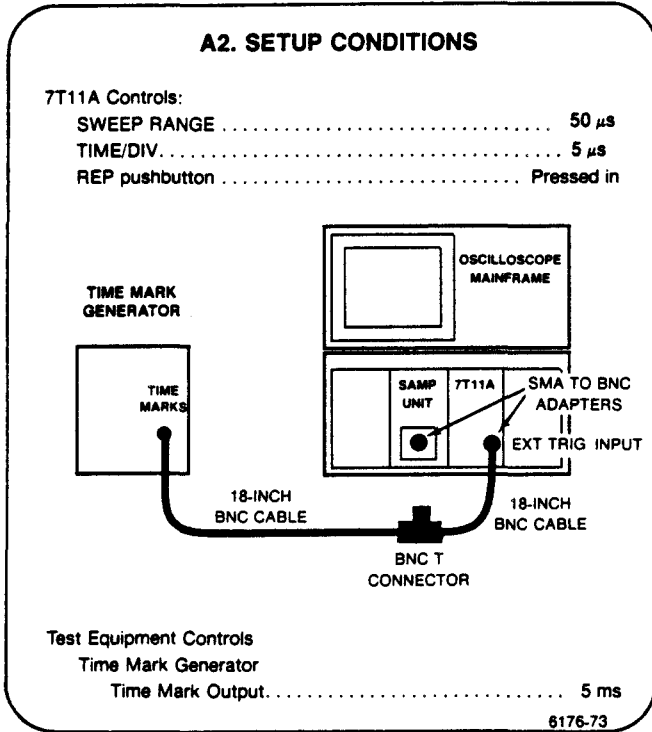

a. Set 7T11A TRIG LEVEL for a free running sweep.

b. Press the 7T11A MAN pushbutton in. Set the 7T11A SWEEP CAL and POSITION for exactly 10 divisions of dot range, beginning and ending at the graticule edges, while rotating the SCAN control from full counterclockwise to full clockwise.

c. Connect the Time Mark Generator to the Sampling Head input. Set the 7T11A SWEEP RANGE to 50 ms, TIME/DIV to 5 ms, and Scan to REP.

d. **CHECK**—the display for one time mark per division + or -3%. See Figure 5-1 for typical timing displays.

e. **CHECK**—for the sweep length and distance between time marks to become shorter and longer as 7T11A SWEEP CAL is rotated between full counterclockwise and full clockwise.

f. Set SWEEP CAL for exactly 1 time mark per division.

g. **CHECK**—timing accuracy to be within + or -3% by setting 7T11A SWEEP RANGE and TIME/DIV as indicated in Table 5-3 and checking for the corresponding display.

h. Set 7T11A VARIABLE (CAL IN) to Variable by pressing in the knob to release it.

i. **CHECK**—for the distance between time marks to increase as the VARIABLE control is rotated clockwise and for the distance to increase at least 2.5 times the calibrated value when the control is at full clockwise (see Figure 5-1).

j. Set 7T11A VARIABLE to calibrated operation by pressing the knob to latch it in the CAL IN position.

**TABLE 5-3**  
**Timing**

SWEEP RANGE	TIME/DIV	TIME MARK GENERATOR	DISPLAY	SWEEP START EXCLUDED
50 $\mu$ s	5 $\mu$ s <sup>1</sup>	5 $\mu$ s	1 marker/div	
50 $\mu$ s	2 $\mu$ s	2 $\mu$ s	1 marker/div	
50 $\mu$ s	1 $\mu$ s	1 $\mu$ s	1 marker/div	
50 $\mu$ s	.5 $\mu$ s	.5 $\mu$ s	1 marker/div	
50 $\mu$ s	.2 $\mu$ s	.2 $\mu$ s	1 marker/div	
50 $\mu$ s	.1 $\mu$ s	.1 $\mu$ s	1 marker/div	
50 $\mu$ s	50 ns	50 ns	1 marker/div	
50 $\mu$ s	20 ns	20 ns	1 marker/div	5 $\mu$ s
50 $\mu$ s	10 ns	10 ns	1 marker/div	
5 $\mu$ s	.5 $\mu$ s <sup>1</sup>	.5 $\mu$ s	1 marker/div	
.5 $\mu$ s	50 ns <sup>1</sup>	50 ns	1 marker/div	
50 ns	5 ns <sup>1</sup>	5 ns	1 marker/div	
.5 ms	50 $\mu$ s	50 $\mu$ s	1 marker/div	2.5 $\mu$ s
5 ms	.5 ms	.5 ms	1 marker/div	25 $\mu$ s
50 ms	5 ms	5 ms	1 marker/div	250 $\mu$ s

<sup>1</sup> Check at both RANDOM and SEQUENTIAL switch settings.

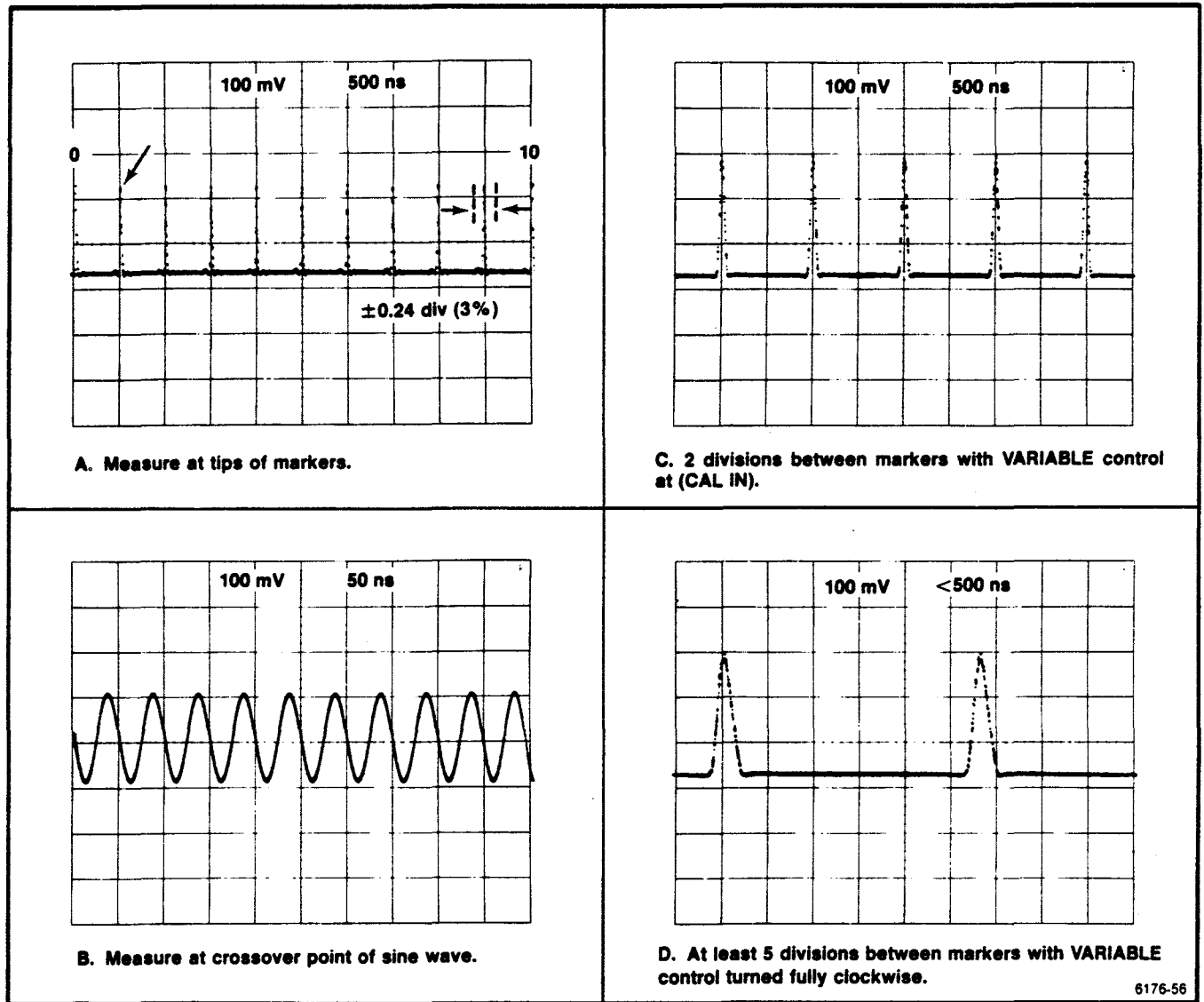

Figure 5-1. Typical displays for checking timing accuracy.

**Checks and Adjustment—7T11A**  
**Part I—Performance Check**

**A3. CHECK REPETITIVE SCAN RATE**

**NOTE**

*If the previous step was not performed, first perform step A1.*

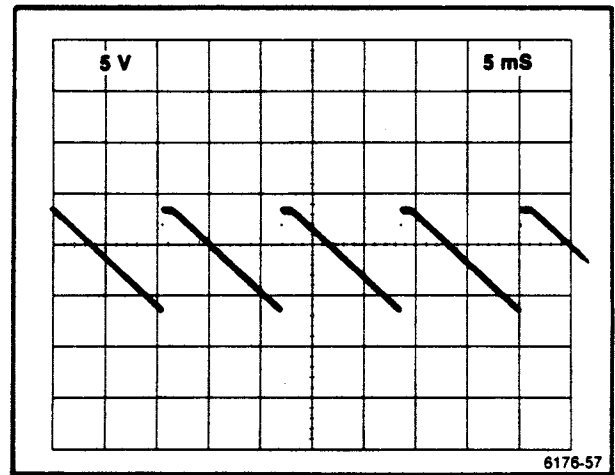

**Figure 5-2. Sweep Out waveform to check Repetitive Scan rate.**

**A3. SETUP CONDITIONS**

**7T11A Controls:**  
 SCAN ..... Full clockwise  
 SWEEP RANGE ..... 50  $\mu$ s  
 TIME/DIV ..... 5  $\mu$ s

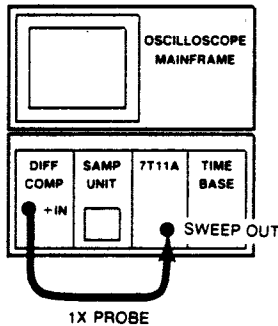

**Test Equipment Controls:**  
**Oscilloscope Mainframe**  
 Vertical Mode ..... Left  
 Horizontal Mode ..... B  
**Differential Comparator**  
 Volts/Div ..... 5  
 + Input ..... DC  
 - Input ..... GND  
**Time Base**  
 Time/Div ..... 5 ms

6176-74

a. **CHECK**—the display for 25 ms or less per sawtooth (see Figure 5-2).

b. Set the Time Base Time/Div to .1 s and set 7T11A SCAN to full counterclockwise.

c. **CHECK**—the display for 500 ms or more per sawtooth.

**A4. CHECK SWEEP OUT**

**NOTE**

If the previous step was not performed, first perform step A1.

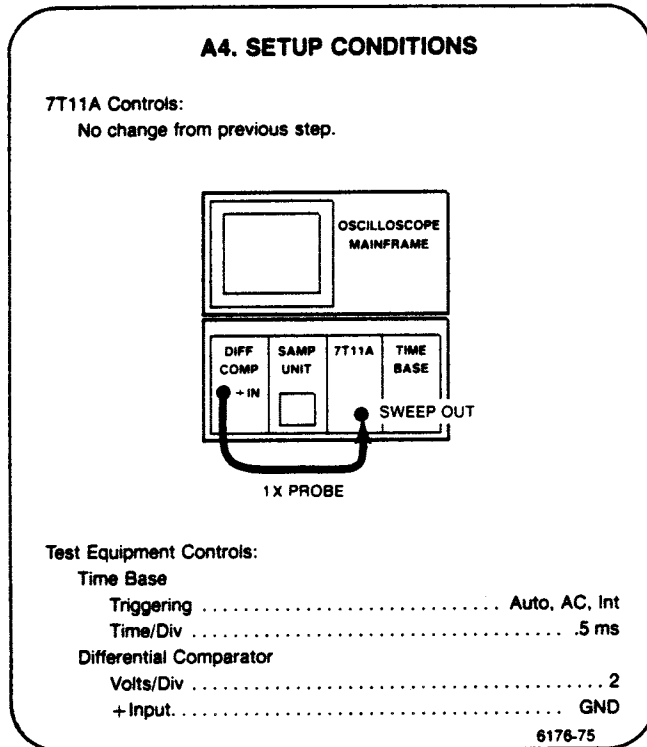

a. Use the Differential Comparator Position control to center the displayed sweep.

b. Set the Differential Comparator + Input to DC.

c. Press in the 7T11A MAN pushbutton.

d. **CHECK**—the displayed sweep to be at +5 volts with SCAN full counterclockwise and at -5 volts with SCAN full clockwise.

**A5. CHECK EXT INPUT**

**NOTE**

If the previous step was not performed, first perform step A1.

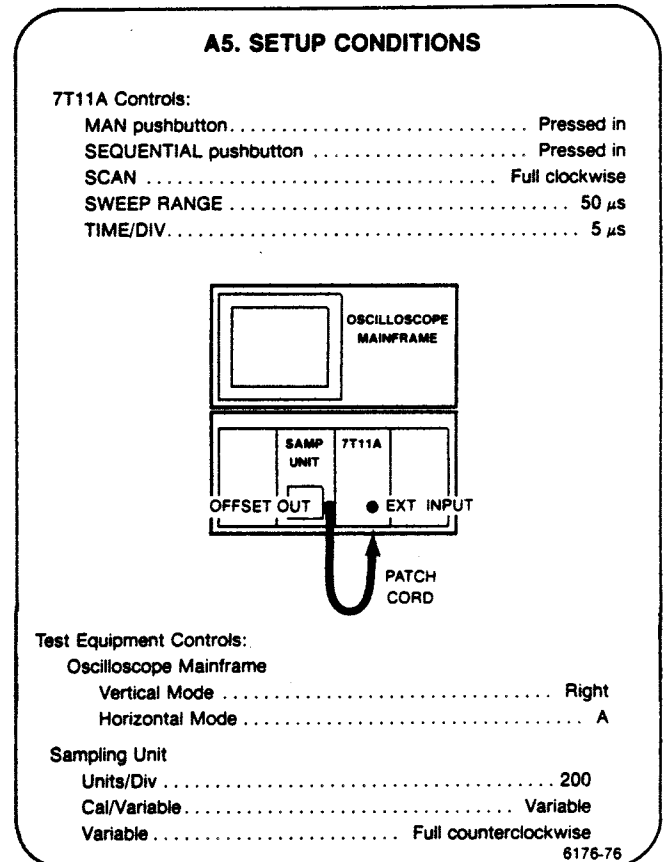

a. **CHECK**—for a dot on the display, positioned near the right graticule edge.

b. Press in the 7T11A EXT INPUT pushbutton. Connect Sampling Unit Offset Out to 7T11A EXT INPUT with a patch cord.

c. Set Sampling Unit Offset to position the dot at the right edge of the graticule.

d. **CHECK**—that the dot moves to the left graticule edge when SCAN is set to full counterclockwise.

## B. TRIGGERING

### Equipment Required:

- |   |                                     |
|---|-------------------------------------|
| 1. Oscilloscope Mainframe               | 13. BNC T Connector                 |
| 2. Sampling Unit                        | 14. SMA to BNC Adapter (2 required) |
| 3. Sampling Head                        | 15. 10X BNC Attenuator              |
| 4. Low Frequency Sine Wave Generator    | 16. 5X BNC Attenuator               |
| 5. Medium Frequency Sine Wave generator | 17. 2X SMA Attenuator               |
| 6. High Frequency Sine Wave Generator   | 18. 18-Inch BNC Cable (2 required)  |
| 7. SHF Signal Generator                 | 19. SMA to GR Adapter               |
| 8. Pulse Generator                      | 20. GR to BNC Adapter (4 required)  |
| 9. 50 $\Omega$ Delay Line               | 21. 50 $\Omega$ BNC Cable           |
| 10. Time Mark Generator                 | 22. GR Power Divider                |
| 11. BSM to BNC cable                    | 23. SMA Power Divider               |
| 12. 50 $\Omega$ SMA Cable (2 required)  | 24. GR T Connector                  |

### BEFORE YOU BEGIN:

(1) Perform the Performance Check Power Up Sequence.

(2) Refer to section 6, Instrument Options, and the Change Information section at the rear of this manual for any modifications that may affect this procedure.

(3) See the **TEST POINT AND ADJUSTMENT LOCATIONS** foldout page in section 8, Diagrams and Circuit Board Illustrations.

### NOTE

*The 7T11A SWEEP RANGE control and TIME POS RNG display window are integral features. In this procedure, SWEEP RANGE settings are identified by the value appearing in the TIME POS RNG window.*

### B1. TRIGGERING PRELIMINARY CONTROL SETTINGS:

7T11A

TIME POSITION ..... Midrange  
 SLOPE ..... (+)

Sampling Unit

Polarity ..... +Up  
 Normal/Smooth ..... Normal

Oscilloscope Mainframe

Vertical Mode ..... Right  
 Horizontal Mode ..... A

**B2. CHECK LOW-FREQUENCY TRIGGERING**

**NOTE**

First perform step B1, then proceed.

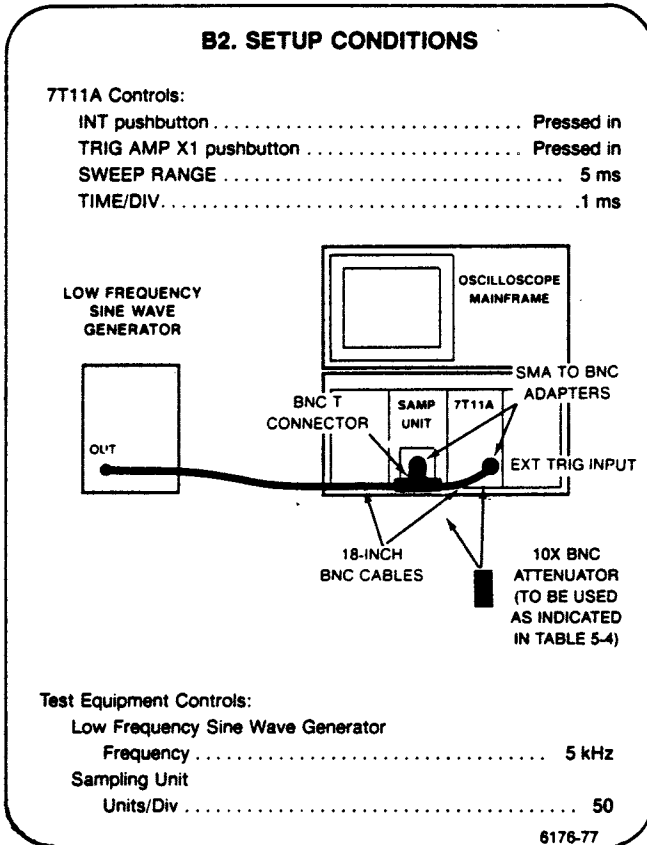

a. **CHECK**—7T11A low-frequency triggering capability by using the control settings and requirements given in Table 5-4 to obtain a stable, triggered display. The signal generator output amplitude is correct when its signal causes the amount of vertical deflection shown under the Display Size column. Add a 10X BNC Attenuator to the 7T11A trigger signal as indicated in the right-hand column of Table 5-4. Set 7T11A STABILIZ and TRIG LEVEL as necessary for a stable display. On real-time ranges TIME POSITION also aids in stabilizing triggering. Changes in control settings between successive steps are indicated in the table with an asterisk.

**NOTE**

To check internal triggering capability from the mainframe's other vertical compartment, an additional sampling unit may be installed and the internal triggering checks repeated for that compartment.

**B3. CHECK-MEDIUM FREQUENCY TRIGGERING**

**NOTE**

If the previous step was not performed, first perform step B1.

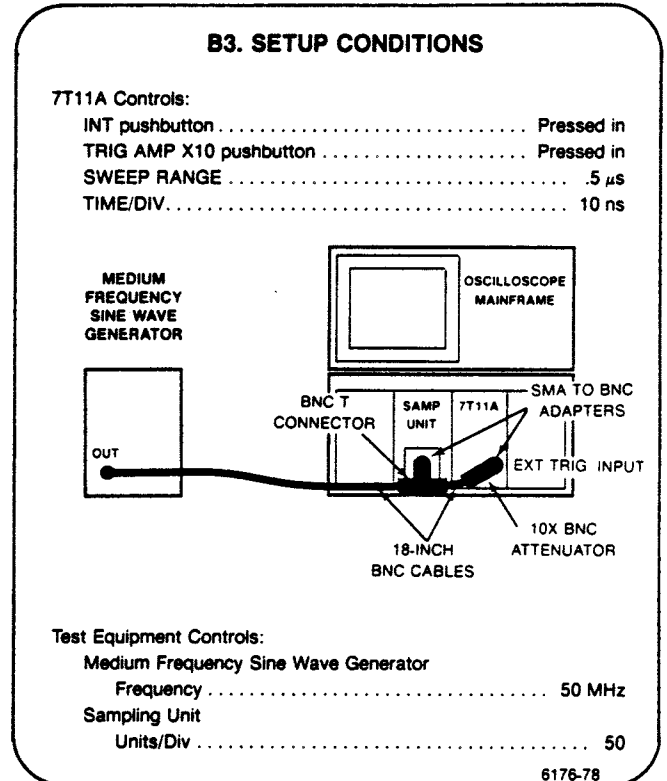

a. **CHECK**—7T11A medium-frequency triggering capability by using the control settings and requirements given in Table 5-5 to obtain a stable, triggered display. The signal generator output amplitude is correct when its signal causes the amount of vertical deflection shown under the Display Size column. Set 7T11A STABILIZ and TRIG LEVEL as necessary for a stable display. Add a 10X BNC Attenuator to the 7T11A trigger signal as indicated in the right-hand column of Table 5-5. Changes in control settings between successive steps are indicated in the table with an asterisk.

Checks and Adjustment—7T11A  
Part I—Performance Check

TABLE 5-4  
Low-Frequency Triggering

TRIGGERING MODE	SAMPLING UNIT UNITS/DIV	7T11A				GENERATOR FREQUENCY	GENERATOR OUTPUT	DISPLAY SIZE	10X ATTENUATOR
		SWEEP RANGE	TIME/DIV	TRIG AMP	TRIG MODE				
INTERNAL	50	5 ms	.1 ms	X1	INT	5 kHz	125 mV	2.5 div	NONE
INTERNAL	5*	5 ms	.1 ms	X10*	INT	5 kHz	12.5 mV	2.5 div	NONE
INTERNAL	200*	5 ms	.1 ms	X10	INT	5 kHz	1 V	5 div	NONE
EXTERNAL	5*	5 ms	.5 ms*	X10	EXT 50 Ω*	1 kHz*	12.5 mV	2.5 div	TRIGGER SIGNAL
EXTERNAL	5	5 ms	.5 ms	X10	EXT 1 MΩ*	1 kHz	12.5 mV	2.5 div	TRIGGER SIGNAL
EXTERNAL	50*	50 ms*	5 ms*	X1*	EXT 1 MΩ	50 Hz*	125 mV	2.5 div	TRIGGER SIGNAL
EXTERNAL	5*	50 ms	5 ms	X1*	EXT 50 Ω*	50 Hz	12.5 mV	2.5 div	TRIGGER SIGNAL

TABLE 5-5  
Medium-Frequency Triggering

TRIGGERING MODE	SAMPLING UNIT UNITS/DIV	7T11A				GENERATOR FREQUENCY	GENERATOR OUTPUT	DISPLAY SIZE	10X ATTENUATOR
		SWEEP RANGE	TIME/DIV	TRIG AMP	TRIG MODE				
INTERNAL	50	.5 μs	10 ns	X10	INT	50 MHz	125 mV	2.5 div	TRIGGER SIGNAL
EXTERNAL	5*	.5 μs	10 ns	X10	EXT 50 Ω*	50 MHz	12.5 mV	2.5 div	TRIGGER SIGNAL
EXTERNAL	5	.5 μs	10 ns	X10	EXT 1 MΩ*	50 MHz	12.5 mV	2.5 div	TRIGGER SIGNAL
EXTERNAL	50*	.5 μs	10 ns	X1*	EXT 1 MΩ	100 MHz*	125 mV	2.5 div	TRIGGER SIGNAL

TABLE 5-6  
High-Frequency Triggering

TRIGGERING MODE	SAMPLING UNIT UNITS/DIV	7T11A				GENERATOR FREQUENCY	GENERATOR OUTPUT	DISPLAY SIZE	10X ATTENUATOR
		SWEEP RANGE	TIME/DIV	TRIG AMP	TRIG MODE				
INTERNAL	50	50 ns	1 ns	X1	INT	500 MHz	125 mV	2.5 div	10X AT SIGNAL INPUT
EXTERNAL	100*	50 ns	.5 ns*	X1	EXT 50 Ω*	1 GHz*	625 mV	6.25 div	5X + 10X AT TRIGGER INPUT
EXT HF SYNC	100	50 ns	.5 ns	X1	EXT HF SYNC*	1 GHz	500 mV	5 div	10X AT TRIGGER INPUT
EXT HF SYNC	100	50 ns	.5 ns	X1	EXT HF SYNC	1 GHz	500 mV	5 div	NONE



**B4. CHECK HIGH-FREQUENCY TRIGGERING**

**NOTE**

If the previous step was not performed, first perform step B1.

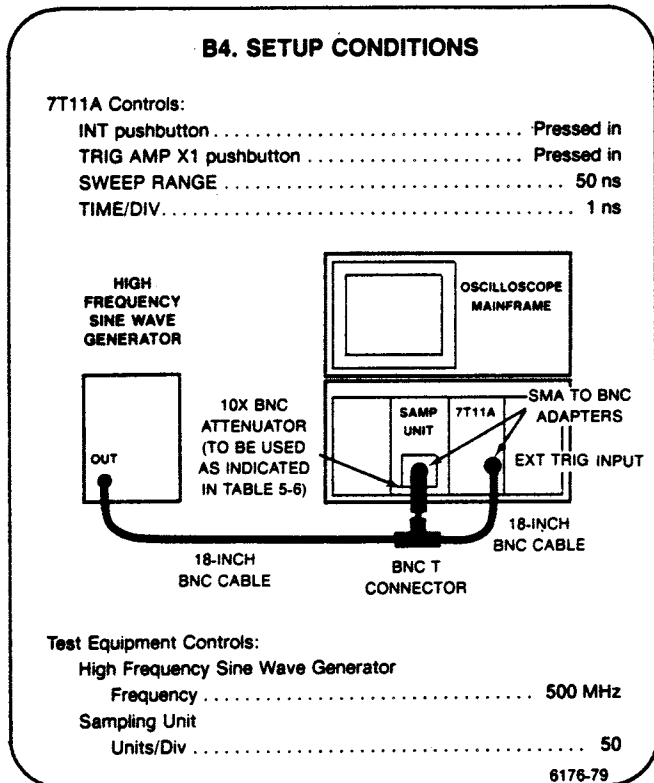

a. **CHECK**—7T11A high-frequency triggering capability by using the control settings and requirements given in Table 5-6 to obtain a stable, triggered display. The signal generator output amplitude is correct when its signal causes the amount of vertical deflection shown under the Display Size column. Set 7T11A STABILITY and TRIG LEVEL as necessary for a stable display. Add BNC Attenuators to the 7T11A trigger input signal or Sampling Unit signal input as indicated in the right-hand column of Table 5-6. Changes in control settings between successive steps are indicated in the table with an asterisk.

**B5. CHECK 12.4 GHz HF SYNC TRIGGERING**

**NOTE**

If the previous step was not performed, first perform step B1.

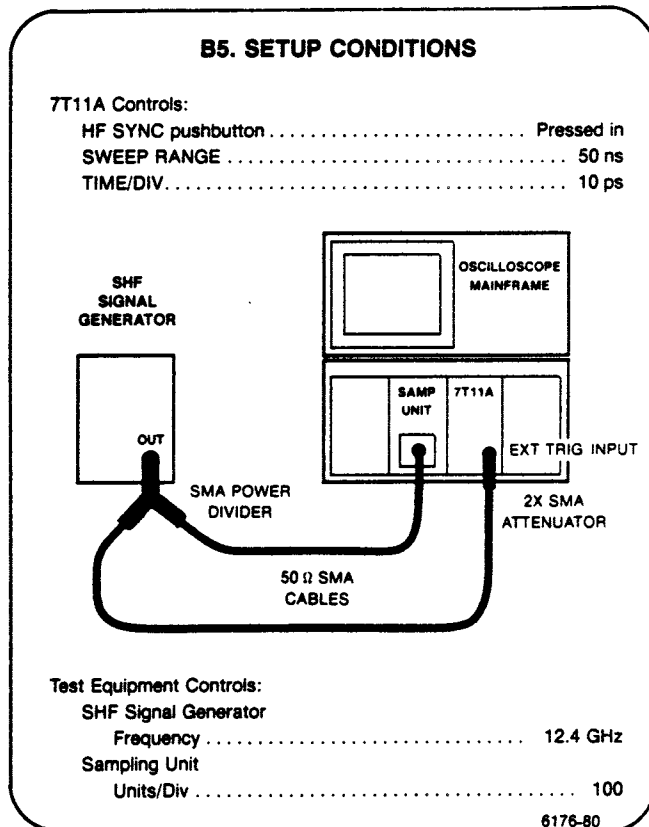

a. **CHECK**—that a stable, triggered waveform providing 200 mV of trigger signal to the 7T11A can be obtained on the oscilloscope with the 7T11A STABILITY and TRIG LEVEL controls along with the signal generator Amplitude control.

b. Set the Sampling Unit Units/Div to 200.

c. **CHECK**—that a stable, triggered waveform providing 500 mV of trigger signal to the 7T11A can be obtained on the oscilloscope with the 7T11A STABILITY and TRIG LEVEL controls along with the signal generator Amplitude control.

**Checks and Adjustment—7T11A**  
**Part I—Performance Check**

**B6. CHECK SEQUENTIAL-MODE DISPLAY JITTER AT FASTEST SWEEP RANGE POSITION**

**NOTE**

*If the previous step was not performed, first perform step B1.*

c. Set the Sampling Unit Units/Div to 2 and use DC Off-set and 7T11A TIME POSITION to keep the pulse leading edge visible.

d. While maintaining best possible display stability, rotate TIME/DIV to the 10 ps position.

e. **CHECK**—the oscilloscope display for less than 10 ps of jitter as shown in Figure 5-3B.

**NOTE**

*If display jitter exceeds the specified 10 ps value, the cause may be excessive trigger jitter or jitter by other circuits in the sampling system. The procedure of step C10 of Part II-Performance Check and Adjustment removes the trigger portion of display jitter, and is therefore a troubleshooting aid.*

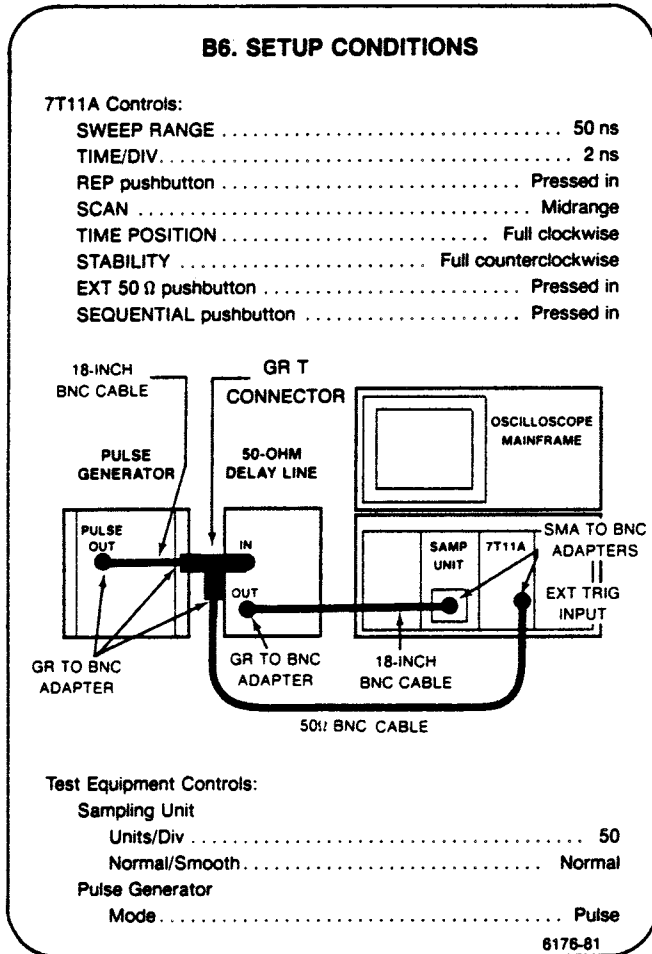

a. Set 7T11A TRIG LEVEL, if necessary for a display such as that shown in Figure 5-3A.

b. Rotate the TIME/DIV control clockwise to .2 ns, one step at a time, while using TIME POSITION, STABILITY, and TRIG LEVEL to maintain best possible stability of the displayed pulse leading edge.

**B7. CHECK RANDOM-MODE DISPLAY JITTER AT FASTEST SWEEP RANGE POSITION**

**NOTE**

If the previous step was not performed, first perform step B1.

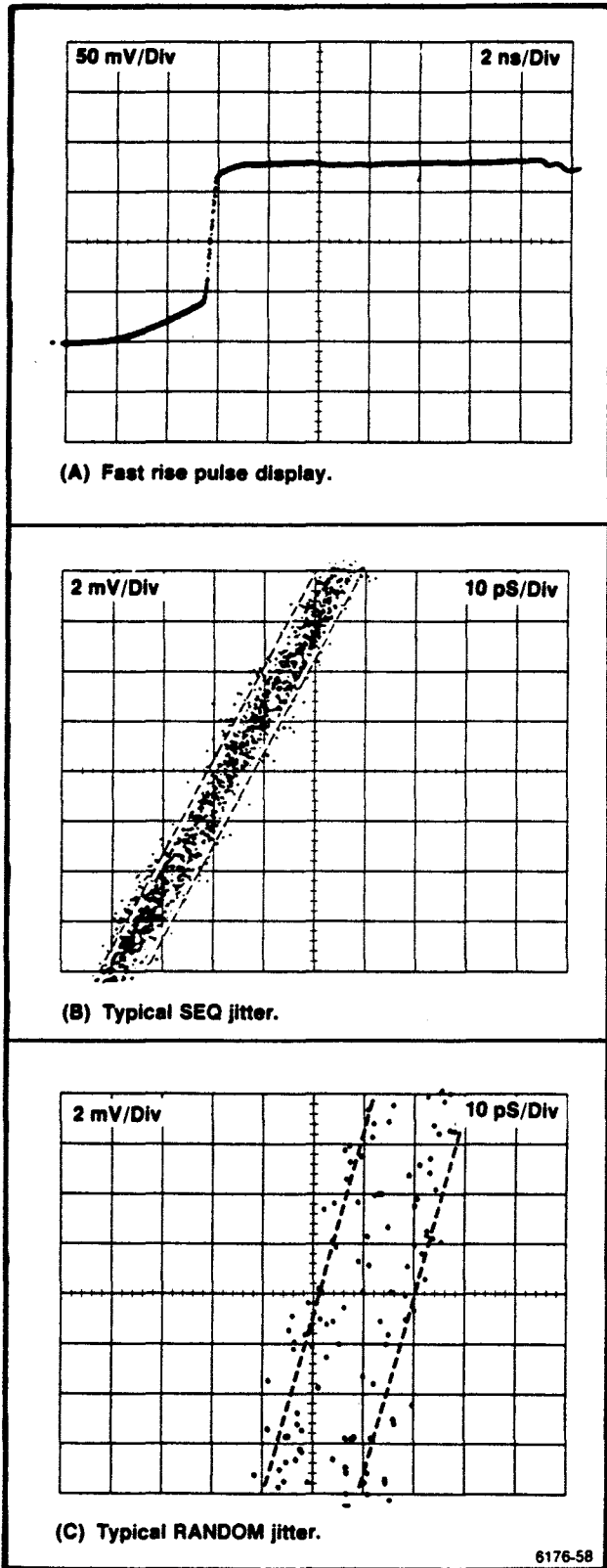
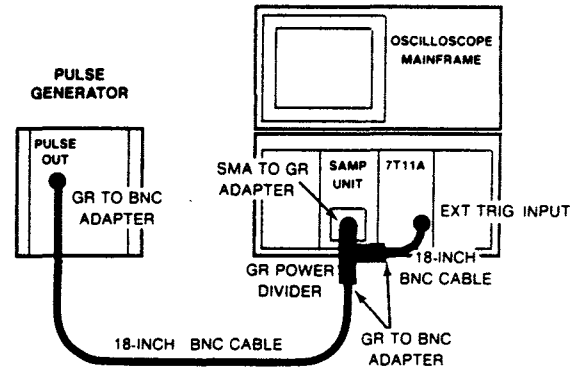

Figure 5-3. Determining display jitter.

**B7. SETUP CONDITIONS**

7T11A Controls:

RANDOM pushbutton ..... Pressed in  
MAN pushbutton ..... Pressed in



Test Equipment Controls:

No change in settings from previous step.

6176-82

- Set 7T11A TRIG LEVEL, if necessary for a display such as that shown in Figure 5-3A.
- Rotate the TIME/DIV control clockwise to .2 ns, one step at a time, while using TIME POSITION, STABILITY, and TRIG LEVEL to maintain best possible display stability of the pulse leading edge.
- Set the Sampling Unit Units/Div to 2 and use DC Offset and 7T11A TIME POSITION to keep the pulse leading edge visible.
- While maintaining best possible display stability, rotate TIME/DIV to the 10 ps position.
- CHECK**—the oscilloscope display for less than 30 ps of jitter as shown in Figure 5-3C.

**NOTE**

If display jitter exceeds the specified 30 ps value, the cause may be excessive trigger jitter or jitter by other circuits in the sampling system. The procedure of step C10 in Part II-Performance Check and Adjustment removes the trigger portion of display jitter, and is therefore a troubleshooting aid.

**Checks and Adjustment—7T11A**  
**Part I—Performance Check**

**B8. CHECK DISPLAY JITTER AT REMAINING SWEEP RANGE POSITIONS**

**NOTE**

*If the previous step was not performed, first perform step B1.*

**B8. SETUP CONDITIONS**

7T11A Controls:  
 SEQUENTIAL pushbutton ..... Pressed in  
 SWEEP RANGE ..... .5  $\mu$ s  
 TIME/DIV ..... .1 ns  
 REP pushbutton ..... Pressed in  
 EXT 50  $\Omega$  2 V MAX pushbutton ..... Pressed in  
 SCAN ..... Midrange

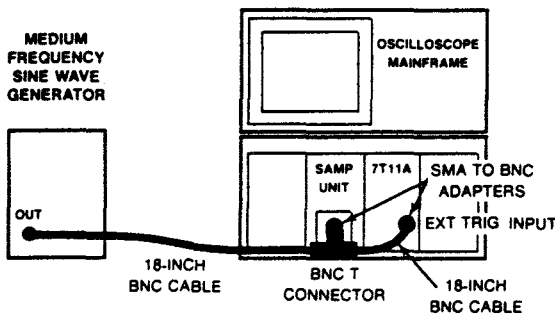

Test Equipment Controls:  
 Medium Frequency Sine Wave Generator  
 Frequency ..... 250 MHz  
 Sampling Unit  
 Units/Div ..... 50

6176-83

**NOTE**

*If display jitter exceeds the specified value, the cause may be excessive trigger jitter or jitter by other circuits in the sampling system. The procedure of step C10 in Part II-Performance Check and Adjustment removes the trigger portion of display jitter, and is therefore a troubleshooting aid.*

b. Disconnect the Medium Frequency Sine Wave Generator and connect the Low Frequency Sine Wave Generator in its place.

c. **CHECK**—the oscilloscope display for jitter using the settings and requirements given in Table 5-7B. Carefully adjust 7T11A STABILITY and TRIG LEVEL for minimum jitter before a measurement is made.

**TABLE 5-7**  
**Display Jitter with Optimum Trigger Conditions**

7T11A				GENERATOR FREQUENCY	DISPLAY JITTER
SCAN MODE	SAMPLING MODE	SWEEP RANGE	TIME/DIV		
(A) SEQUENTIAL AND RANDOM OPERATION					
REP	SEQUENTIAL	.5 $\mu$ s	.1 ns	250 MHz	$\leq 0.4$ division
REP		5 $\mu$ s	1 ns	75 MHz	
REP		50 $\mu$ s	10 ns	7.5 MHz	
MAN	RANDOM	.5 $\mu$ s	.1 ns	250 MHz	$\leq 1$ division
MAN		5 $\mu$ s	1 ns	75 MHz	
MAN		50 $\mu$ s	10 ns	7.5 MHz	
(B) REAL TIME OPERATION					
REP	REAL TIME	.5 ms	.1 $\mu$ s	350 kHz	$\leq 0.4$ division
REP		5 ms	1 $\mu$ s	50 kHz	
REP		50 ms	10 $\mu$ s	5 kHz	

**B9. CHECK HF SYNC DISPLAY JITTER**

**NOTE**

If the previous step was not performed, first perform step B1.

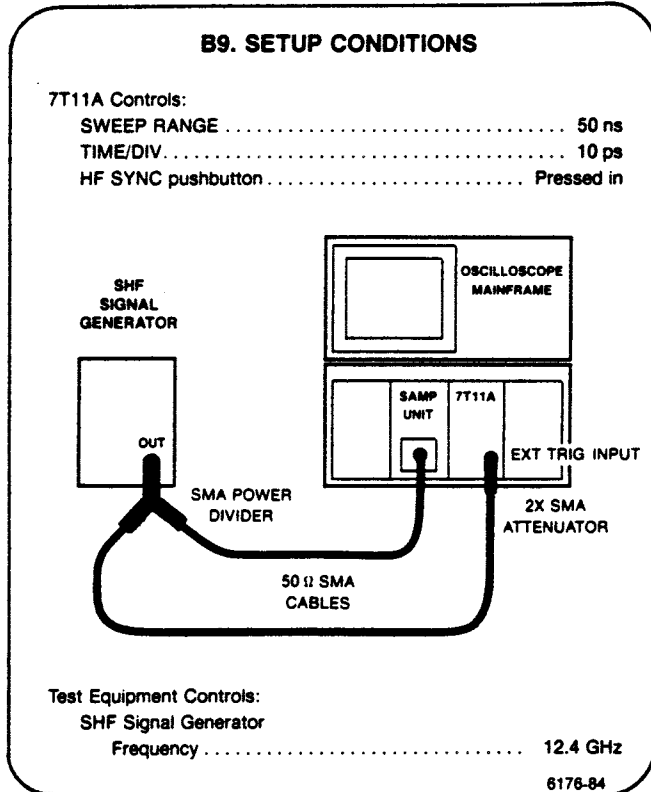

a. Set the signal generator Amplitude and Sampling Unit Units/Div controls to provide at least 200 mV of trigger signal to the 7T11A and display a steep enough waveform slope to accurately measure jitter.

b. CHECK—for 20 ps or less of display jitter.

**NOTE**

If display jitter exceeds the specified value, the cause may be excessive trigger jitter or jitter by other circuits in the sampling system. The procedure of step C10 in Part II-Performance Check and Adjustment removes the trigger portion of display jitter, and is therefore a troubleshooting aid.

**B10. CHECK PULSE OUT INTO 50 Ω**

**NOTE**

If the previous step was not performed, first perform step B1.

**B10. SETUP CONDITIONS**

7T11A Controls:

TIME POSITION .....	Full clockwise
SLOPE .....	(+)
TRIG LEVEL .....	Midrange
STABILITY .....	Full clockwise
RANDOM pushbutton .....	Pressed in
TRIG AMP X1 pushbutton .....	Pressed in
SWEEP RANGE .....	5 μs
TIME/DIV .....	20 ns
INT pushbutton .....	Pressed in
REP pushbutton .....	Pressed in

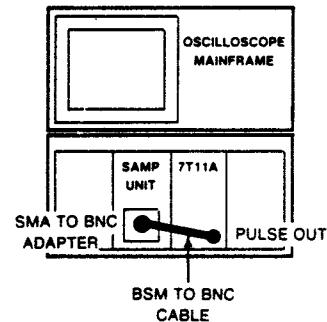

Test Equipment Controls:

Sampling Unit	
+ Up pushbutton .....	Pressed in
DC Offset .....	Centered display
Units/Div .....	100
Normal/Smooth .....	Normal

6176-85

a. Rotate 7T11A TIME POSITION counterclockwise to display the rising portion of the pulse.

b. CHECK—the display for at least 400 mV of signal amplitude (see Figure 5-4A).

c. Set TIME/DIV for 2 ns and Sampling Unit Variable for 5 divisions of amplitude at the rising portion.

d. CHECK—risetime to be 2.5 ns or less as measured between the 10% and 90% amplitude points on the rising portion (center four divisions; see Figure 5-4B).

e. Push the Sampling Unit Variable control back in.

**Checks and Adjustment—7T11A**  
**Part I—Performance Check**

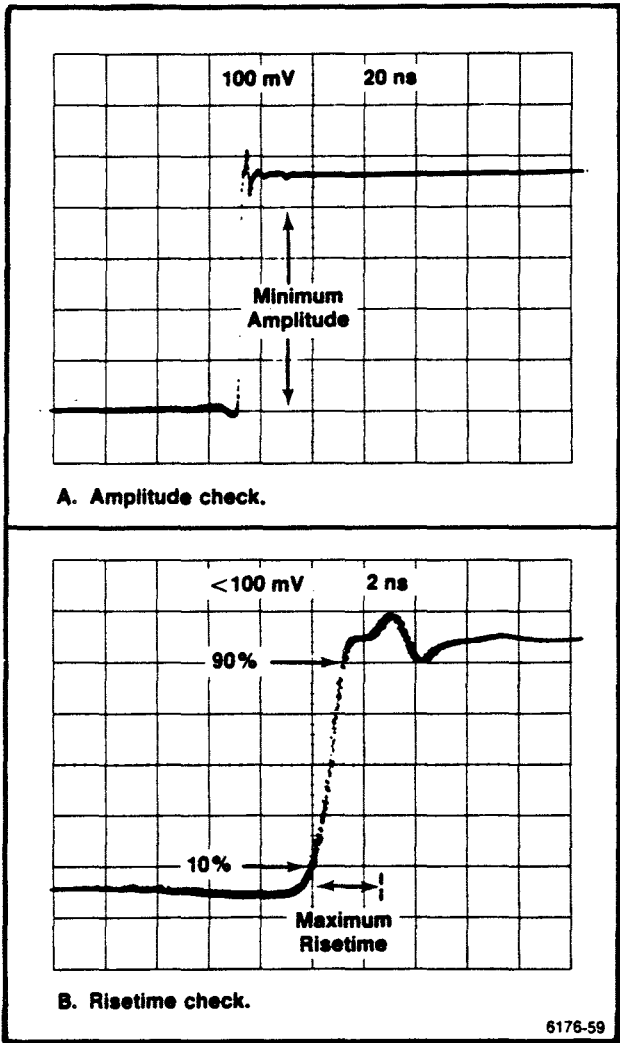

Figure 5-4. Typical display of the Pulse Out waveform.

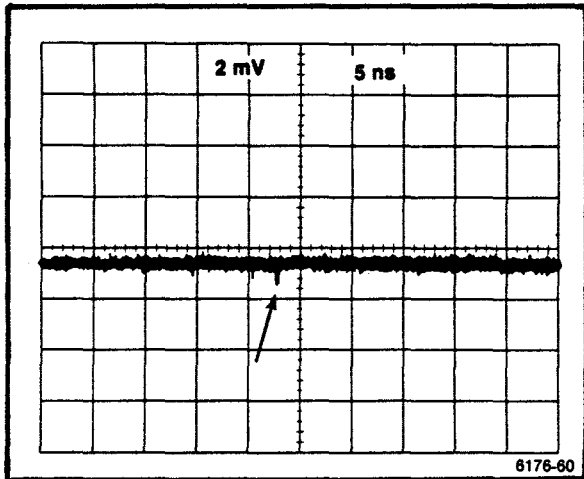

Figure 5-5. Typical display of trigger kickout.

**B11. CHECK TRIGGER KICK OUT**

**NOTE**

*If the previous step was not performed, first perform step B1.*

**B11. SETUP CONDITIONS**

7T11A Controls:

TIME POSITION .....	Full clockwise
FINE .....	Full clockwise
SWEEP RANGE .....	50 ns
TIME/DIV .....	5 ns
INT pushbutton .....	Pressed in

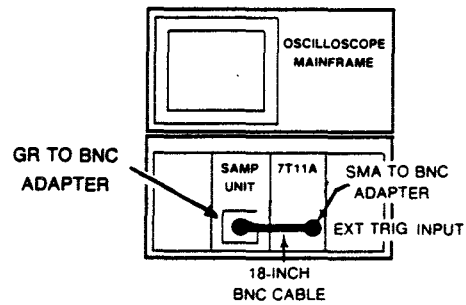

Test Equipment Controls:

Sampling Unit	
Normal/Smooth .....	Smooth
Units/Div .....	2
DC Offset .....	Midrange

6176-86

- a. Install a Sampling Head having less than 2 mV of display noise in the Sampling Unit. Connect the Sampling Head input to the 7T11A EXT TRIG INPUT.
- b. Set Sampling Unit DC Offset to position the trace at graticule center.
- c. **CHECK**—the trigger kickout pulse to be no more than  $\pm 2$  mV (see Figure 5-5).
- d. Replace the Sampling Head with the one previously used.

**B12. CHECK MINIMUM TRIGGER RATE IN  
RANDOM MODE**

*NOTE*

*If the previous step was not performed, first perform  
step B1.*

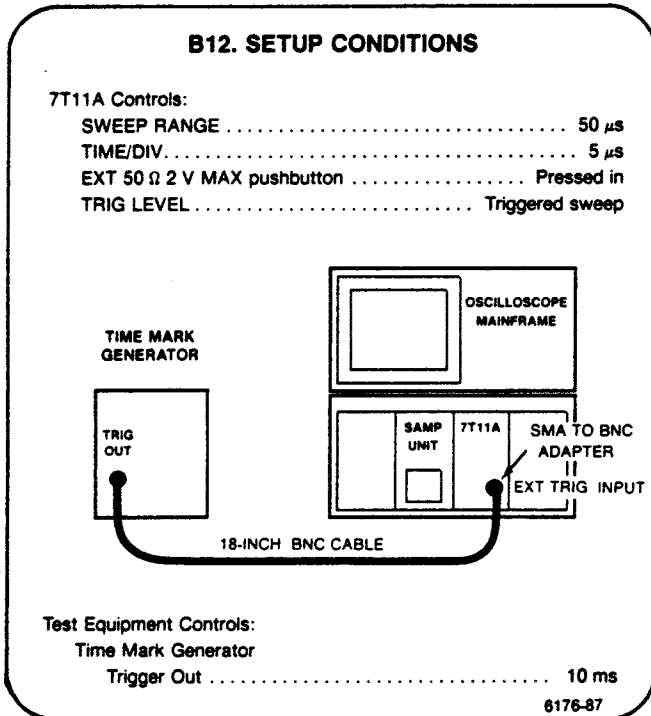

- a. Set 7T11A TRIG LEVEL for a triggered sweep.
- b. **CHECK**—for the displayed sweep length to be at least 9 divisions.

This completes the Part I-Performance Check procedure.

# PART II-PERFORMANCE CHECK AND ADJUSTMENT

The following procedure (Part II-Performance Check and Adjustment) provides the information necessary to: (1) verify that the instrument meets the electrical specifications, (2) verify that all controls function properly, and (3) perform all internal adjustments.

Part I-Performance Check checks the electrical specifications listed in Section 1 without making any internal adjustments.

A separate Operators Checkout Procedure is provided in the Section 2 for familiarization with the instrument and to verify that all front-panel controls and connectors function properly.

## PERFORMANCE CHECK AND ADJUSTMENT INDEX

	PAGE		PAGE
<b>A. TRIGGER ADJUSTMENTS</b>		<b>B9. CHECK SWEEP OUT</b> .....	5-39
A1. TRIGGER ADJUSTMENTS PRELIMINARY CONTROL SETTINGS .....	5-26	<b>B10. EXAMINE/ADJUST SYNC COUNTDOWN</b> ..	5-40
A2. EXAMINE/ADJUST +10 VOLTS .....	5-27	<b>B11. EXAMINE/ADJUST HF SYNC KICKOUT</b> ...	5-41
A3. EXAMINE/ADJUST TRIG LEVEL ZERO AND STAB ZERO .....	5-27	<b>B12. CHECK EXT INPUT</b> .....	5-42
A4. EXAMINE/ADJUST ARMING BIAS AND OUTPUT BIAS .....	5-28	<b>C. TRIGGER OPERATION</b>	
A5. EXAMINE TRIG LEVEL AND STABILITY CONTROL OPERATION .....	5-29	C1. TRIGGER OPERATION PRELIMINARY CONTROL SETTINGS .....	5-43
A6. EXAMINE/ADJUST EXTERNAL TRIGGER ZERO .....	5-30	C2. CHECK LOW-FREQUENCY TRIGGERING ..	5-44
<b>B. SCAN AND TIMING</b>		C3. CHECK MEDIUM-FREQUENCY TRIGGERING .....	5-44
B1. SCAN AND TIMING PRELIMINARY CONTROL SETTINGS .....	5-31	C4. CHECK HIGH-FREQUENCY TRIGGERING ..	5-46
B2. EXAMINE/ADJUST MEMORY GATE BLOWBY .....	5-32	C5. CHECK 12.4 GHz HF SYNC TRIGGERING ..	5-46
B3. ADJUST SLEWING RAMP, SERVO ZERO, DOT POSITION MEMORY, AND RATE SERVO ZERO .....	5-33	C6. CHECK SEQUENTIAL-MODE DISPLAY JITTER AT FASTEST SWEEP RANGE POSITION .....	5-47
B4. EXAMINE POSITION AND SWEEP CAL RANGE .....	5-34	C7. CHECK RANDOM-MODE DISPLAY JITTER AT FASTEST SWEEP RANGE POSITION .....	5-48
B5. EXAMINE/ADJUST REAL TIME ZERO AND MEMORY GATE BAL .....	5-35	C8. CHECK DISPLAY JITTER AT REMAINING SWEEP RANGE POSITIONS ..	5-49
B6. CHECK/ADJUST TIMING .....	5-36	C9. CHECK HF SYNC DISPLAY JITTER .....	5-50
B7. EXAMINE/ADJUST RANDOM TIMING .....	5-38	C10. EXAMINE DISPLAY JITTER NOT DUE TO TRIGGERING .....	5-50
B8. CHECK REPETITIVE SCAN RATE .....	5-39	C11. CHECK PULSE OUT INTO 50 $\Omega$ .....	5-51
		C12. CHECK TRIGGER KICK OUT .....	5-52
		C13. EXAMINE TRIGGER HOLDOFF .....	5-52
		C14. EXAMINE STROBE KICKBACK INTO TRIGGER .....	5-53
		C15. CHECK MINIMUM TRIGGER RATE IN RANDOM MODE .....	5-54



## PERFORMANCE CHECK AND ADJUSTMENT POWER UP SEQUENCE

### NOTE

*7T11A performance can be checked at an ambient temperature from 0° C to +50° C unless otherwise stated. Adjustments must be performed at an ambient temperature from +20° C to +30° C for specified accuracies.*

1. Install a Differential Comparator Plug-in unit in the left vertical compartment and a Time Base Plug-In unit in the B horizontal compartment of the Oscilloscope Mainframe.

2. Remove the side panel covers on the 7T11A and Sampling Unit.

3. Remove the 5/16-inch nut on the 7T11A front-panel TRIG INPUT connector and remove the connector from the front panel.

4. Loosen the four screws holding the Trigger Board and lift the board so it can be supported by the top chassis panel (see Fig. 5-6).

5. Remove the red-on-white coaxial cable at A2J344, top of the 7T11A, and the red-on-white coaxial cable on the Sampling Unit Inter-Channel Control Board. Connect the RF cable assembly between the 7T11A A2J344 connector and the Sampling Unit Sampling Drive connector, with the cable threaded through the Sampling Unit switch portion from the right side. Tape the loose connectors to the chassis to avoid a short circuit. This completes oscillator control and strobe drive circuits so the 7T11A can be operated on a plug-in extender. Position the EXT TRIG INPUT cable and connector to hang over the front of the A3 Trigger board. All External Trigger inputs will still be connected to the SMA coaxial connector in the following procedure as if it were installed on the front panel.

6. Install the Sampling Unit (with the Sampling Head installed) in the right vertical compartment and the 7T11A on an extender in the A horizontal compartment of the Oscilloscope Mainframe.

7. Set the mainframe Intensity controls to minimum. Turn on the mainframe and allow at least 20 minutes warmup before beginning the procedure.

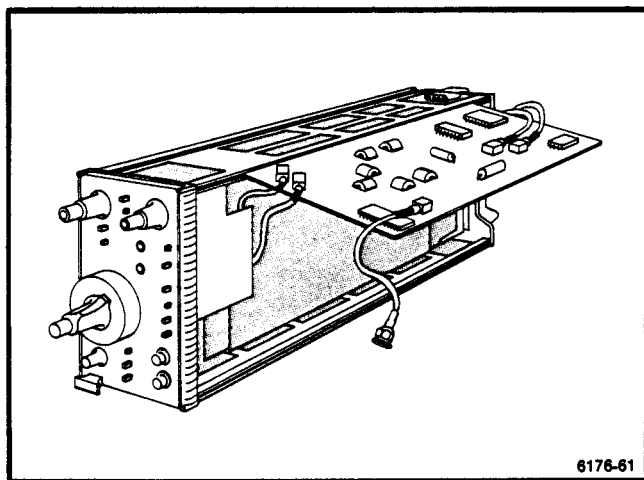

Figure 5-6. Positioning Trigger circuit board for access to internal adjustments.

## A. TRIGGER ADJUSTMENTS

**Equipment Required:**

- |  |  |
|--|--|
| 1. Oscilloscope Mainframe<br>2. Sampling Unit<br>3. Sampling Head<br>4. Differential Comparator Plug-In<br>5. Time Base Plug-In<br>6. Pulse Generator<br>7. 1X Probe | 8. Plug-In Extender<br>9. Special RF Cable Assembly<br>10. Low Capacitance Screwdriver<br>11. SMA to BNC Adapter (2 required)<br>12. GR to BNC Adapter<br>13. 18-inch BNC Cable (2 required)<br>14. 50 Ω BNC Termination |
|--|--|

**BEFORE YOU BEGIN:**

(1) Perform the Performance Check and Adjustment Power Up Sequence.

(2) Refer to Section 6, Instrument Options, and the Change Information section at the rear of this manual for any modifications that may affect this procedure.

(3) See the **TEST POINT AND ADJUSTMENT LOCATIONS** foldout page in Section 8, Diagrams and Circuit Board Illustrations.

**NOTE**

*The 7T11A SWEEP RANGE control and TIME POS RNG display window are integral features. In this procedure, SWEEP RANGE settings are indicated by the value appearing in the TIME POS RNG window.*

### A1. TRIGGER ADJUSTMENTS PRELIMINARY CONTROL SETTINGS

**7T11A**

- TIME POSITION ..... Fully clockwise  
 FINE ..... Fully Clockwise  
 SLOPE ..... (—)  
 TRIG LEVEL ..... Midrange  
 STABILITY ..... Fully Clockwise  
 SEQUENTIAL pushbutton ..... Pressed in  
 TRIG AMP ..... X1

- SWEEP RANGE ..... 50 μs  
 TIME/DIV ..... 5 μs  
 50 Ω 2V MAX pushbutton ..... Pressed in  
 REP pushbutton ..... Pressed in

**Oscilloscope Mainframe**

- Vertical Mode ..... Left  
 Horizontal Mode ..... B

**Sampling Unit**

- + Up ..... Pressed in  
 DC Offset ..... Centered display  
 Units/Div ..... 200  
 Dot Response ..... Midrange  
 Normal pushbutton ..... Pressed in

**Differential Comparator**

- + or - ..... +  
 + Input ..... DC  
 - Input ..... GND  
 BW ..... Full  
 Position ..... Centered display

**Time Base**

- Triggering ..... Auto, AC, Internal  
 Time/Division ..... .1 ms

**A2. EXAMINE/ADJUST +10 VOLTS (A2R600)**

**NOTE**

First perform step A1, then proceed.

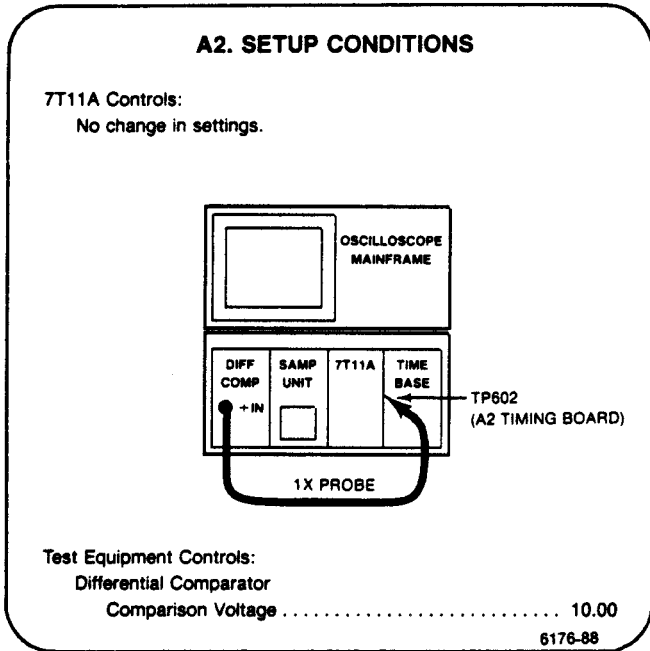

a. Set the Differential Comparator —Input to the Comparison Voltage (Vc).

**NOTE**

*These values are provided only as examples of typical instrument operation. They are not to be considered specifications.*

b. **EXAMINE**—the Comparator display for a reading of +10.00 volts at TP602.

c. **ADJUST**—+10 Volts adjustment R600 for +10.00 volts.

d. Set the Differential Comparator +Input and —Input to GND and remove the probe tip from Test Point 602.

e. **INTERACTION**—Adjustments described in this subsection may interact with other related circuits. If any adjustment is made, it is recommended that the remainder of this procedure subsection be performed.

**A3. EXAMINE/ADJUST TRIG LEVEL ZERO AND STAB ZERO (A3R120, A3R135)**

**NOTE**

First perform steps A1 and A2, then proceed.

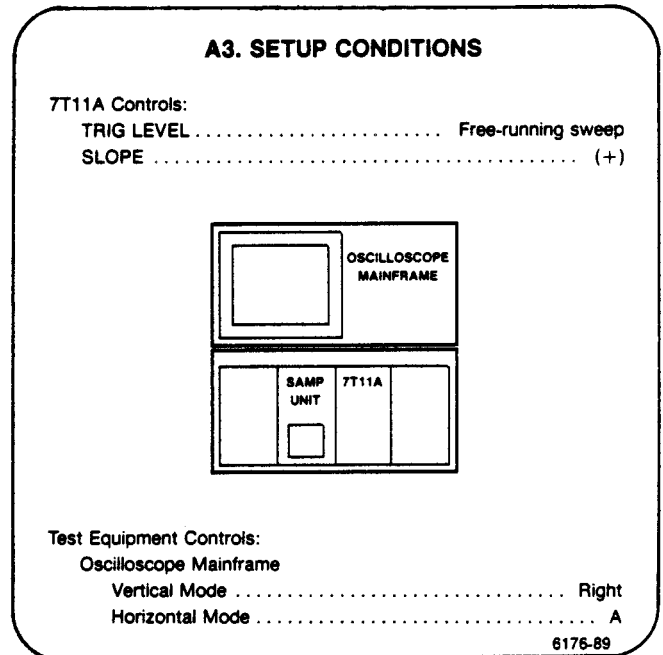

a. Set 7T11A STABILITY as far counterclockwise as possible while still maintaining a free-running sweep. Note the position of the TRIG LEVEL control.

b. Set 7T11A SLOPE to (—).

c. Set 7T11A TRIG LEVEL for a free-running sweep. Note the position of the TRIG LEVEL control.

d. Set 7T11A TRIG LEVEL midway between the two positions just noted.

**NOTE**

*These values are provided only as examples of typical instrument operation. They are not to be considered specifications.*

e. **EXAMINE**—the oscilloscope display for a free-running sweep when the 7T11A SLOPE control is switched to both (+) and (—).

**Checks and Adjustment—7T11A**

**Part II—Performance Check and Adjustment**

f. **ADJUST**—Trig Level Zero adjustment R120 for a free-running sweep in both (+) and (–) positions of the 7T11A SLOPE control.

**NOTE**

The TRIG LEVEL control knob may be repositioned to put its indicator mark in the twelve o'clock position when set to the operating midpoint. After determining the operating midpoint in the previous steps, carefully loosen the knob setscrew, reposition the knob, and retighten the set screw. Check the TRIG LEVEL control for smooth operation afterward by rotating it throughout its range.

g. **EXAMINE**—the oscilloscope display for no sweep when 7T11A STABILITY is set to full counterclockwise and TRIG LEVEL is rotated throughout its range.

h. **EXAMINE**—the display to ensure that TRIG LEVEL can be set for a free-running sweep when STABILITY is set approximately 90 degrees from counterclockwise.

i. **ADJUST**—Stab Zero adjustment R135 for no sweep when STABILITY is full counterclockwise, regardless of TRIG LEVEL settings, and for a sweep to be achievable with TRIG LEVEL when STABILITY is set approximately 90 degrees from full counterclockwise.

**NOTE**

If difficulties are encountered, try performing the following step, A4, and then returning to this adjustment.

j. **INTERACTION**—Adjustments described in this subsection may interact with other related circuits. If any adjustment is made, it is recommended that the remainder of this procedure subsection be performed and the entire subsection repeated.

**A4. EXAMINE/ADJUST ARMING BIAS AND OUTPUT BIAS (A3R145, A3R155)**

**NOTE**

If the previous step was not performed, first perform step A1.

**A4. SETUP CONDITIONS**

7T11A Controls:  
 SWEEP RANGE ..... 50 ns  
 TIME/DIV ..... 1 ns  
 SLOPE ..... (+)  
 50 Ω 2 V MAX pushbutton ..... Pressed in  
 STABILITY ..... Full Counterclockwise  
 TRIG LEVEL ..... Full Clockwise

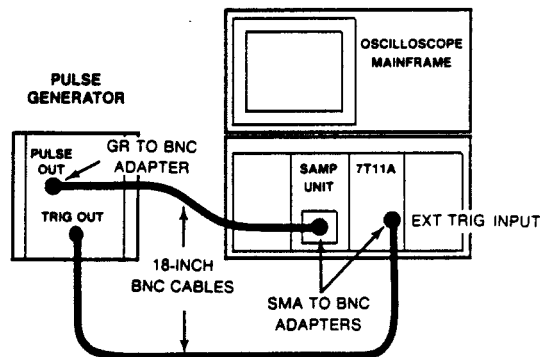

Test Equipment Controls:  
 Oscilloscope Mainframe  
 Vertical Mode ..... Right  
 Horizontal Mode ..... A  
 Pulse Generator  
 Mode ..... Pulse  
 Sampling Unit  
 Units/Div ..... Four divisions display amplitude

6176-90

a. Set 7T11A TIME POSITION and TRIG LEVEL (if necessary) to view the pulse leading edge on the oscilloscope.

b. Set 7T11A TRIG LEVEL for least jitter on the pulse leading edge (typically optimum when TRIG LEVEL is set full clockwise).

**NOTE**

These values are provided only as examples of typical instrument operation. They are not to be considered specifications.

c. **EXAMINE**—pulse leading edge for stability (no jitter). 7T11A sweep speed may be increased to better view small amounts of jitter.

d. **ADJUST**—Arming Bias adjustment R145 to full counterclockwise. Slowly adjust R145 clockwise until the pulse leading edge either jumps to the right or begins to break up. Adjust R145 back counterclockwise until the pulse stabilizes or jumps back to its original position (the point just before the initial jump or break-up occurred).

e. **ADJUST**—Output Bias adjustment R155 to full counterclockwise. Slowly adjust R155 clockwise until the pulse leading edge either jumps to the right or begins to break up. Adjust R155 back counterclockwise until the pulse stabilizes or jumps back to its original position (the point just before the initial jump or break-up occurred).

f. **INTERACTION**—Adjustments described in this subsection may interact with other related circuits. If any adjustment is made, it is recommended that the remainder of this procedure subsection be performed and the entire subsection repeated.

**A5. EXAMINE TRIG LEVEL AND STABILITY CONTROL OPERATION**

**NOTE**

*If the previous step was not performed, first perform step A1.*

**A5. SETUP CONDITIONS**

7T11A Controls:

SWEEP RANGE .....	50 ns
TIME/DIV .....	1 ns
STABILITY .....	Full counterclockwise
SLOPE .....	(+)
EXT 50 Ω 2 V MAX pushbutton .....	Pressed in

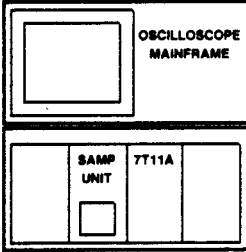

The diagram shows two pieces of equipment. The top one is labeled 'OSCILLOSCOPE MAINFRAME' and has a rectangular display area. The bottom one is labeled '7T11A' and has a 'SAMP UNIT' knob on its left side.

Test Equipment Controls:

Oscilloscope Mainframe	
Vertical Mode .....	Right
Horizontal Mode .....	A

6178-91

a. Set 7T11A STABILITY to full counterclockwise.

**NOTE**

*These values are provided only as examples of typical instrument operation. They are not to be considered specifications.*

b. **EXAMINE**—the oscilloscope display for no free-running sweep while rotating 7T11A TRIG LEVEL throughout its range and that the knob indicator moves at least 90 degrees to either side of the twelve o'clock position.

c. Set 7T11A TRIG LEVEL at twelve o'clock.

d. Slowly rotate STABILITY clockwise while simultaneously rotating TRIG LEVEL throughout its range until a free running sweep is obtained on the oscilloscope display.

e. **EXAMINE**—the position of the STABILITY control to be between 60 and 90 degrees from its counterclockwise stop.

f. Set 7T11A SLOPE to (-) and repeat parts a through e.

**Checks and Adjustment—7T11A**  
**Part II—Performance Check and Adjustment**

**A6. EXAMINE/ADJUST EXTERNAL TRIGGER ZERO (A3R80, A3R45)**

**NOTE**

*If the previous step was not performed, first perform step A1.*

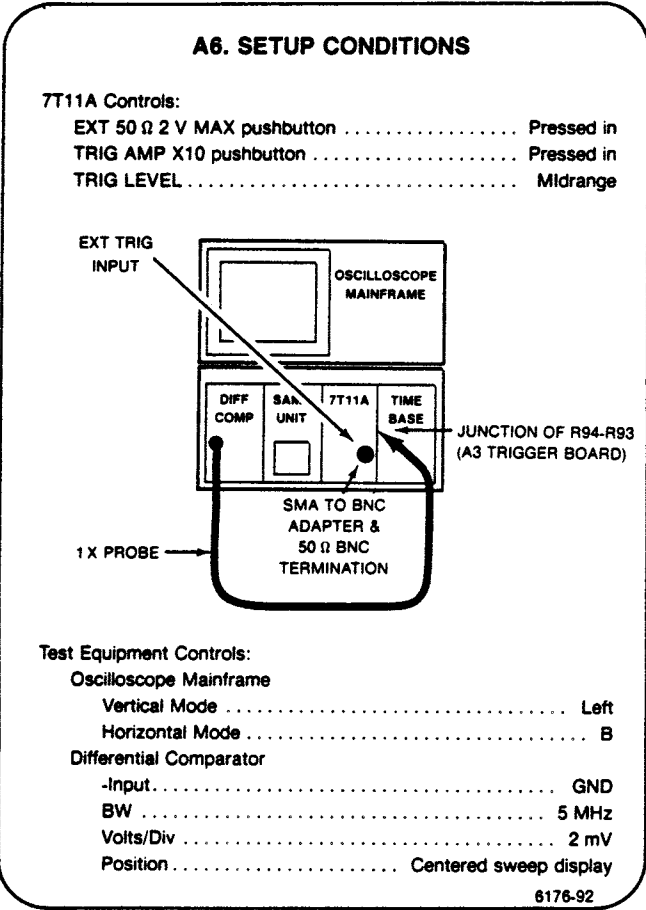

a. **EXAMINE**—the oscilloscope display for 0 V within 4 mV (use the center of the display ac component as the point of reference).

**NOTE**

*These values are provided only as examples of typical instrument operation. They are not to be considered specifications.*

b. **ADJUST**—X10 Zero adjustment R80 for 0 volts on the oscilloscope display.

c. Press in the 7T11A EXT 1 MΩ pushbutton and connect the X1 probe to the junction of R53-R56 on Trigger Board assembly A3.

d. **EXAMINE**—the oscilloscope display for 0 V within 2 mV (use the center of the display ac component as the point of reference).

e. **ADJUST**—1M Zero adjustment R45 for 0 V within 2 mV on the oscilloscope display.

f. **INTERACTION**—Adjustments described in this subsection may interact with other related circuits. If any adjustment is made, it is recommended that the remainder of this procedure subsection be performed and the entire subsection repeated.

## B. SCAN AND TIMING

### Equipment Required:

- |                                     |                                     |
|-------------------------------------|-------------------------------------|
| 1. Oscilloscope Mainframe           | 9. Plug-In Extender.                |
| 2. Sampling Unit.                   | 10. Special RF Cable Assembly.      |
| 3. Sampling Head.                   | 11. Low Capacitance Screwdriver.    |
| 4. Time Mark Generator              | 12. 5X BNC Attenuator               |
| 5. Differential Comparator Plug-In. | 13. 18-Inch BNC Cable (2 required)  |
| 6. Time Base Plug-In.               | 14. SMA TO BNC Adapter (2 required) |
| 7. 1X Probe.                        | 15. BNC T Connector                 |
| 8. 10X Probe.                       | 16. Patch Cord                      |

### BEFORE YOU BEGIN:

(1) Perform the Performance Check and Adjustment Power Up Sequence.

(2) Refer to section 6, Instrument Options, and the Change Information section at the rear of this manual for any modifications that may affect this procedure.

(3) See the **TEST POINT AND ADJUSTMENT LOCATIONS** foldout page in section 8, Diagrams and Circuit Board Illustrations.

### NOTE

*The 7T11A SWEEP RANGE control and TIME POS RNG display window are integral features. In this procedure, SWEEP RANGE settings are identified by the value appearing in the TIME POS RNG window.*

### B1. SCAN AND TIMING PRELIMINARY CONTROL SETTINGS

7T11A

TIME POSITION .....	Fully clockwise
FINE .....	Fully clockwise
SLOPE .....	(-)
TRIG LEVEL .....	Midrange
STABILITY .....	Fully clockwise
SEQUENTIAL Pushbutton .....	Pressed in
SWEEP RANGE .....	50 $\mu$ S
TIME/DIV .....	5 $\mu$ S
VAR .....	CAL
REP Pushbutton .....	Pressed in
SCAN .....	Midrange

Sampling Unit

DC Offset .....	Midrange
Units/Div .....	100

Oscilloscope Mainframe

Vertical Mode .....	Right
Horizontal Mode .....	A

**B2. EXAMINE/ADJUST MEMORY GATE BLOWBY (A2R550)**

**NOTE**

First perform step B1, then proceed.

**NOTE**

These values are provided only as examples of typical instrument operation. They are not to be considered specifications.

b. **EXAMINE**—the oscilloscope display for no blowby spikes to be visible on the Differential Comparator trace (see Figure 5-7 for a display with blowby spikes).

c. **ADJUST**—Memory Gate Bal adjustment R550 (on Timing board assembly A2) for no blowby spikes on the Differential Comparator trace.

d. **INTERACTION**—Adjustments described in this subsection may interact with other related circuits. If any adjustment is made, it is recommended that the remainder of this procedure subsection be performed and the entire subsection repeated.

**B2. SETUP CONDITIONS**

7T11A control settings:

TRIG LEVEL .....	Midrange
STABILITY .....	Full clockwise
SWEEP RANGE .....	50 $\mu$ s
TIME/DIV .....	5 $\mu$ s
MAN pushbutton .....	Pressed in
SCAN .....	Midrange
EXT 50 $\Omega$ 2 V MAX .....	Pressed in
SLOPE .....	(+)
SEQUENTIAL pushbutton .....	Pressed in

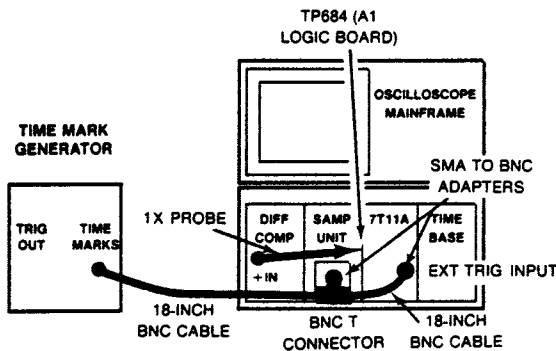

Test Equipment controls:

<b>Oscilloscope Mainframe</b>	
Vertical Mode .....	Alt
Horizontal Mode .....	Chop
<b>Time Mark Generator</b>	
Time Marks out .....	5 $\mu$ s
<b>Sampling Unit</b>	
Units/Div .....	200
Normal/Smooth .....	Normal
+ Up/Invert .....	+ Up
DC Offset .....	Midrange
<b>Differential Comparator</b>	
Volts/Div .....	.2
+ Input .....	DC
- Input .....	GND
Bandwidth .....	5 MHz
Position .....	Midrange
<b>Time Base</b>	
Triggering .....	Auto, AC, Int
Time/Div .....	2 ms

6176-94

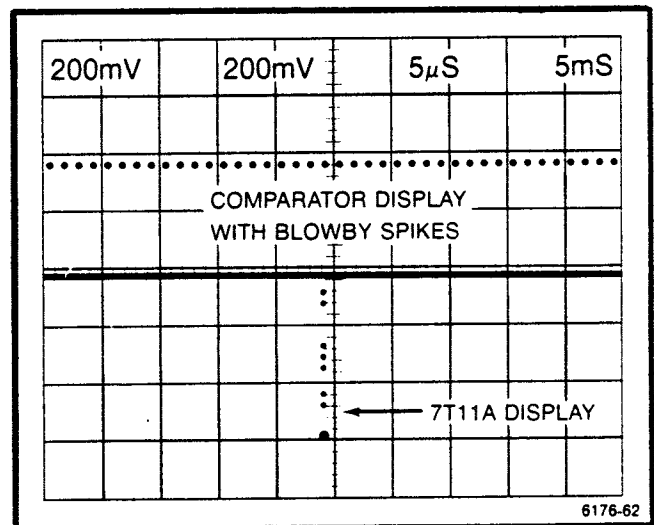

Figure 5-7. Typical display of Memory Gate blowby.



**B3. ADJUST SLEWING RAMP, SERVO ZERO, DOT POSITION MEMORY, AND RATE SERVO ZERO (A2R310, A2R588, A2R645, A2R440)**

**NOTE**

If the previous step was not performed, first perform step B1.

**B3. SETUP CONDITIONS**

7T11A Controls:

SEQUENTIAL pushbutton	.....	Pressed in
SCAN	.....	Full clockwise
SWEEP RANGE	.....	50 $\mu$ S
TIME/DIV	.....	5 $\mu$ S
REP pushbutton	.....	Pressed in

1X PROBE

TP658 (A1)  
LOGIC BOARD

Test Equipment Controls:

Oscilloscope Mainframe	
Vertical Mode	..... Alt
Horizontal Mode	..... Chop
Time Base	
Triggering	..... Auto, AC, Int
Time/Div	..... 10 ms
Differential Comparator	
+ Input	..... GND
- Input	..... GND
Volts/Div	..... 2 mV
BW	..... 5 MHz

6176-95

- a. Set 7T11A TRIG LEVEL for a free running 7T11A sweep on the oscilloscope display
- b. Set the Differential Comparator Position control for a centered trace on the display.
- c. Set the Differential Comparator + Input to DC.

**NOTE**

These values are provided only as examples of typical instrument operation. They are not to be considered specifications.

- d. **ADJUST**—Slewing Ramp adjustment R310 (on Timing board assembly A2) for minimum ac and Servo Zero adjustment R588 (on Logic board assembly A1) for 0 V dc on the Comparator oscilloscope display (center the ac waveform component on the display graticule; see Figure 5-8).

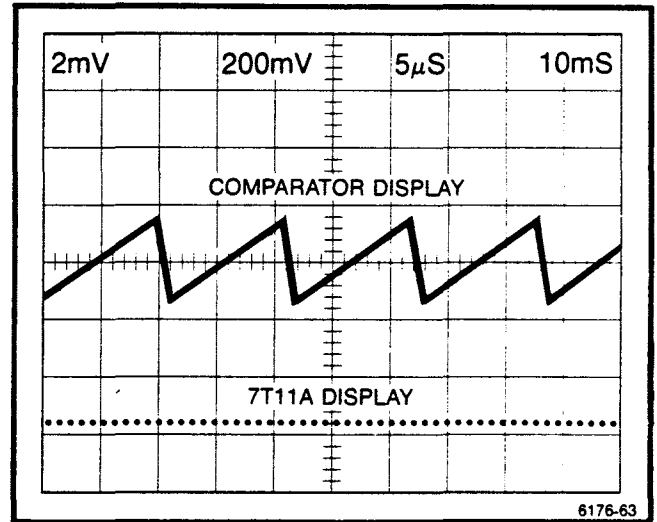

Figure 5-8. Typical display for adjusting Slewing Ramp (A2R310) and Servo Zero (A1R588).

- e. Press in the 7T11A MAN pushbutton and set SCAN to full counterclockwise.
- f. **ADJUST**—Dot Position Memory adjustment R645 (on Logic board assembly A1) for an unblanked dot on the oscilloscope display while adjusting Servo Zero adjustment R588 to maintain 0 V on the Comparator display (see Figure 5-9).

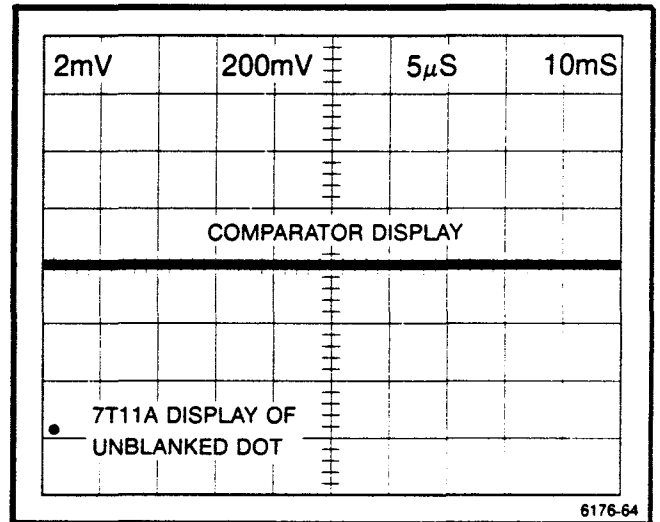

Figure 5-9. Typical display for adjusting Dot Position Memory (A1R645) and Servo Zero (A1R588).

- g. Press in 7T11A RANDOM and REP pushbuttons.
- h. **ADJUST**—Rate Servo Zero adjustment R440 (on Timing board assembly A2) for 0 V dc on the Comparator oscilloscope display.
- i. **INTERACTION**—Adjustments described in this subsection may interact with other related circuits. If any adjustment is made, it is recommended that the remainder of this procedure subsection be performed and the entire subsection repeated.

**Checks and Adjustment—7T11A**  
**Part II—Performance Check and Adjustment**

**B4. EXAMINE POSITION AND SWEEP CAL RANGE**

**NOTE**

*If the previous step was not performed, first perform step B1.*

c. **EXAMINE**—dot movement on the display to be at least + and -0.6 division from graticule center when 7T11A POSITION is rotated from full counterclockwise to full clockwise.

d. Set 7T11A Variable SCAN to full clockwise and POSITION to full counterclockwise. Note the position of the dot on the oscilloscope display.

e. **EXAMINE**—dot movement on the display to be at least + and -0.3 division from its initial position when 7T11A SWEEP CAL is rotated from full counterclockwise to full clockwise.

f. Set SWEEP CAL and POSITION to their calibrated positions as described in part a.

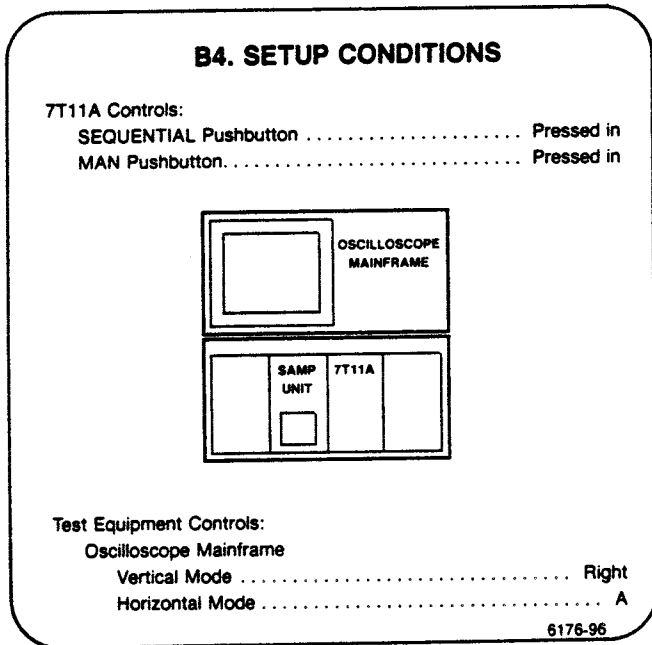

a. Set front-panel SWEEP CAL and POSITION for exactly 10 divisions of range when SCAN is rotated from full counterclockwise to full clockwise.

**NOTE**

*If the dot blanks at either side of the display graticule, readjust Dot Position Memory in the previous step.*

b. Set 7T11A Variable SCAN to position the dot at graticule center on the oscilloscope display.

**NOTE**

*These values are provided only as examples of typical instrument operation. They are not to be considered specifications.*

**B5. EXAMINE/ADJUST REAL TIME ZERO AND MEMORY GATE BAL (A2R500, A2R550)**

**NOTE**

If the previous step was not performed, first perform step B1.

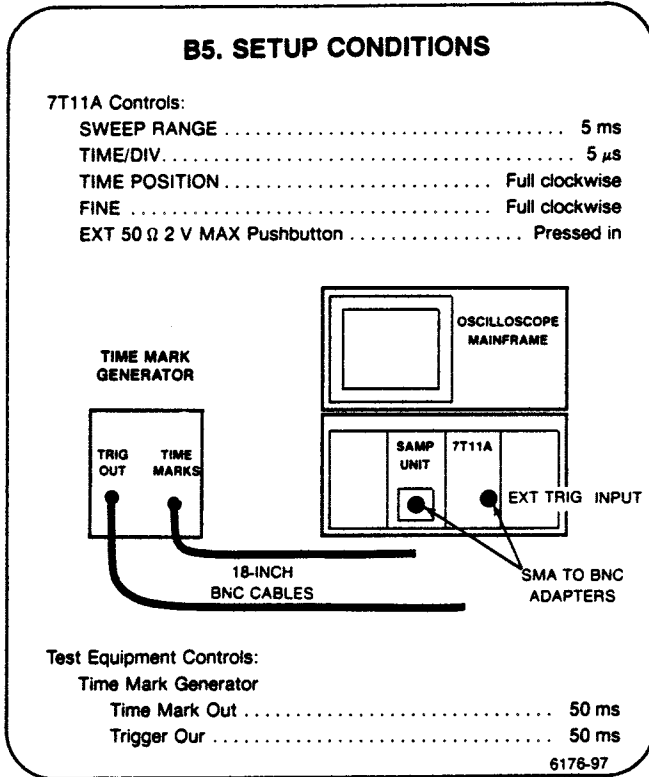

e. Connect 50 ms time marks to the Sampling Head and the Time Mark Generator trigger output to the 7T11A EXT TRIG INPUT connector.

f. **EXAMINE**—the display for the first time mark leading edge to be on or to the right of the left graticule edge while rotating 7T11A TIME/DIV and SWEEP RANGE through all Real-Time sweep settings (0.1  $\mu$ s to 5 ms).

g. **ADJUST**—Real Time Zero adjustment R500 and Memory Gate Bal adjustment R550 (both on Timing board assembly A2) to position the first time mark leading edge on or to the right of the left graticule edge while rotating 7T11A TIME/DIV and SWEEP RANGE through all Real-Time sweep settings (0.1  $\mu$ s to 5 ms).

h. **INTERACTION**—To reduce interaction, R555 may be adjusted at the lowest SWEEP RANGE setting and R500 adjusted while rotating the SWEEP RANGE control through the other Real-Time settings. Adjustments described in this subsection may interact with other related circuits. If any adjustment is made, it is recommended that the remainder of this procedure subsection be performed and the entire subsection repeated.

a. Set 7T11A TRIG LEVEL and STABILITY for a free running sweep.

b. **EXAMINE**—the oscilloscope display for the sweep to begin at the left graticule boundary (graticule position 0).

**NOTE**

*These values are provided only as examples of typical instrument operation. They are not to be considered specifications.*

c. **ADJUST**—Real Time Zero adjustment R500 (on Timing board assembly A2) to align the start of the sweep with the left graticule edge.

d. Set 7T11A TIME/DIV to .5ms and repeat part b.

**Checks and Adjustment—7T11A**  
**Part II—Performance Check and Adjustment**

**B6. CHECK/ADJUST TIMING (A2R265, A2R260, A2C292, A2C313, A2C237, A2R588, A2R310)**

**NOTE**

If the previous step was not performed, first perform step B1.

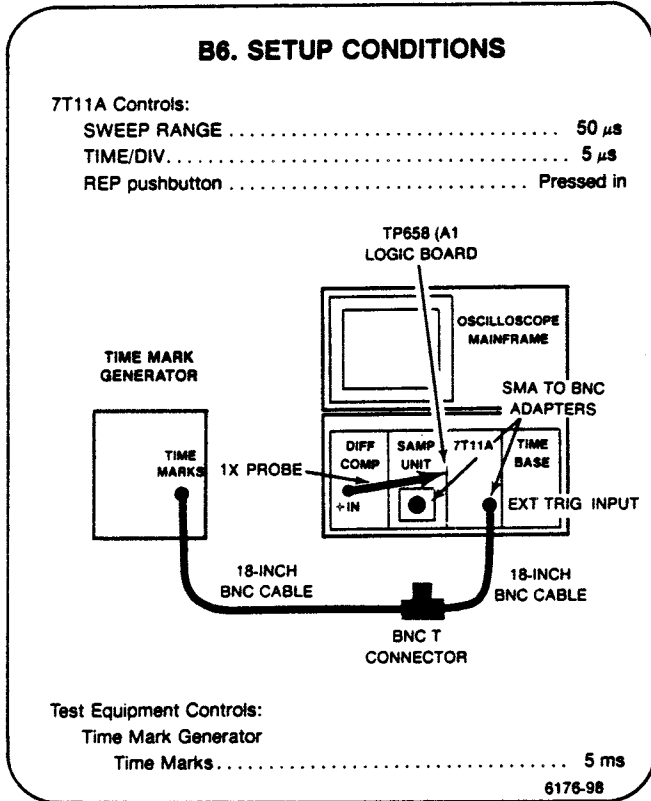

- a. Set 7T11A TRIG LEVEL for a free running sweep.
- b. Press the 7T11A MAN pushbutton in. Set 7T11A SWEEP CAL and POSITION for exactly 10 divisions of dot range, beginning and ending at the graticule edges, while rotating the SCAN control from full counterclockwise to full clockwise.
- c. Connect the Time Mark Generator to the Sampling Head input. Set the 7T11A SWEEP RANGE to 50 ms, TIME/DIV to 5 ms, and Scan to REP.
- d. **CHECK**—the display for one time mark per division  $\pm$  3%. See Figure 5-10 for typical timing displays.
- e. **ADJUST**—Slow Timing adjustment R265 (on Timing board assembly A2) for one time mark per division.
- f. **CHECK**—for the sweep length and distance between time marks to become shorter and longer as 7T11A SWEEP CAL is rotated between full counterclockwise and full clockwise.
- g. Set SWEEP CAL for exactly 1 time mark per division.
- h. Set 7T11A SWEEP RANGE to .5 ms and the Time Mark Generator to 50  $\mu$ s .

- i. **CHECK**—display for one time mark per division  $\pm$  3%.
- j. **ADJUST**—Fast Timing adjustment R260 (on Timing board assembly A2) for one time mark per division.
- k. Set 7T11A SWEEP RANGE to 50 ns and the Time Mark Generator to 10 ns.
- l. **CHECK**—display for one cycle every two divisions  $\pm$  3%.
- m. **ADJUST**—50 ns Timing adjustment C292 (on Timing board assembly A2) for one cycle every two divisions.
- n. Set the Oscilloscope Mainframe Vertical Mode to Alt and Horizontal Mode to Chop.

**NOTE**

The values in parts o and p are provided only as examples of typical instrument operation. They are not to be considered specifications.

- o. **ADJUST**—Gate Comp adjustment C237 for 0 V dc and 50 ns Slewing adjustment C313 (both on Timing board assembly A2) for minimum ac on the Differential Comparator display.

**TABLE 5-8**  
**Timing**

SWEEP RANGE	TIME/DIV	TIME MARK GENERATOR	DISPLAY	SWEEP START EXCLUDED
50 $\mu$ s	5 $\mu$ s <sup>1</sup>	5 $\mu$ s	1 marker/div	
50 $\mu$ s	2 $\mu$ s	2 $\mu$ s	1 marker/div	
50 $\mu$ s	1 $\mu$ s	1 $\mu$ s	1 marker/div	
50 $\mu$ s	.5 $\mu$ s	.5 $\mu$ s	1 marker/div	
50 $\mu$ s	.2 $\mu$ s	.2 $\mu$ s	1 marker/div	
50 $\mu$ s	.1 $\mu$ s	.1 $\mu$ s	1 marker/div	
50 $\mu$ s	50 ns	50 ns	1 marker/div	
50 $\mu$ s	20 ns	20 ns	1 marker/div	5 $\mu$ s
50 $\mu$ s	10 ns	10 ns	1 marker/div	
5 $\mu$ s	.5 $\mu$ s <sup>1</sup>	.5 $\mu$ s	1 marker/div	
.5 $\mu$ s	50 ns <sup>1</sup>	50 ns	1 marker/div	
50 ns	5 ns <sup>1</sup>	5 ns	1 marker/div	
.5 ms	50 $\mu$ s	50 $\mu$ s	1 marker/div	2.5 $\mu$ s
5 ms	.5 ms	.5 ms	1 marker/div	25 $\mu$ s
50 ms	5 ms	5 ms	1 marker/div	250 $\mu$ s

<sup>1</sup> Check at both RANDOM and SEQUENTIAL switch settings.

- p. Set 7T11A SWEEP RANGE to 50  $\mu$ s .
- q. **ADJUST**—Servo Zero adjustment R588 (on Logic board assembly A3) for 0 V dc and Slewing Ramp adjustment R310 (on Timing board assembly A2) for minimum ac on the Differential Comparator display.
- r. Set the Oscilloscope Mainframe Vertical Mode to Right and Horizontal Mode to A.
- s. **CHECK**—timing accuracy to be within  $\pm 3\%$  by setting 7T11A SWEEP RANGE and TIME/DIV as indicated in Table 5-8 and checking for the corresponding display.

t. Set 7T11A VARIABLE (CAL IN) to Variable by pressing in the knob to release it.

u. **CHECK**—for the distance between time marks to increase as the VARIABLE control is rotated clockwise and for the distance to increase to at least 2.5 times the calibrated value when the control is at full clockwise.

v. Set 7T11A VARIABLE to Calibrated by pressing the knob to latch it in the CAL IN position.

w. **INTERACTION**—Adjustments described in this subsection may interact with other related circuits. If any adjustment is made, it is recommended that the remainder of this procedure subsection be performed and the entire subsection repeated.

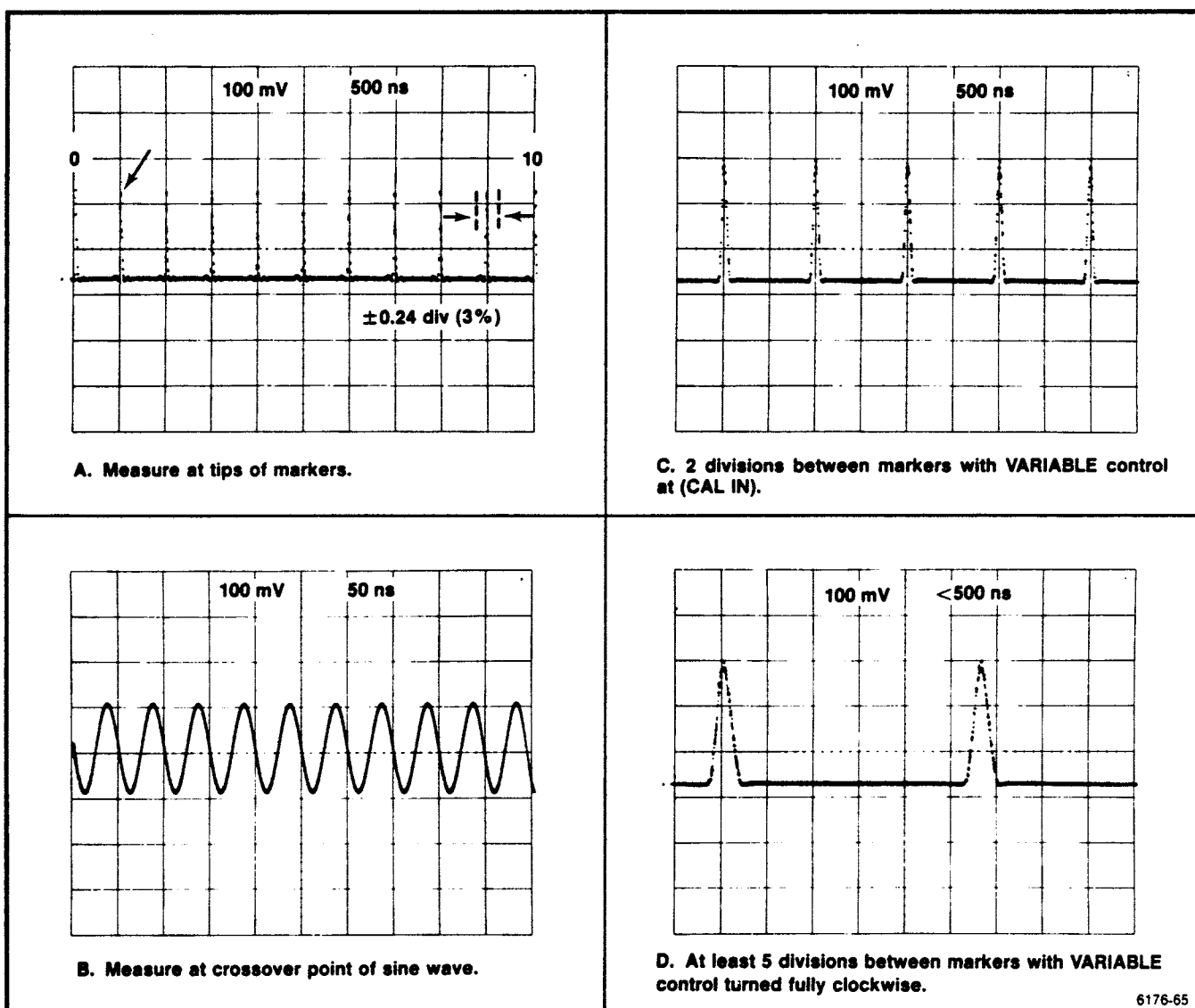

Figure 5-10. Typical displays for checking timing accuracy.

6176-65

**Checks and Adjustment—7T11A**  
**Part II—Performance Check and Adjustment**

**B7. EXAMINE/ADJUST RANDOM TIMING (A2R270)**

**NOTE**

First perform step B1, then proceed.

c. **ADJUST**—Random Timing adjustment R270 (on Timing board assembly A2) to eliminate the pulling in the display.

d. **INTERACTION**—Adjustments described in this subsection may interact with other related circuits. If any adjustment is made, it is recommended that the remainder of this procedure subsection be performed and the entire subsection repeated.

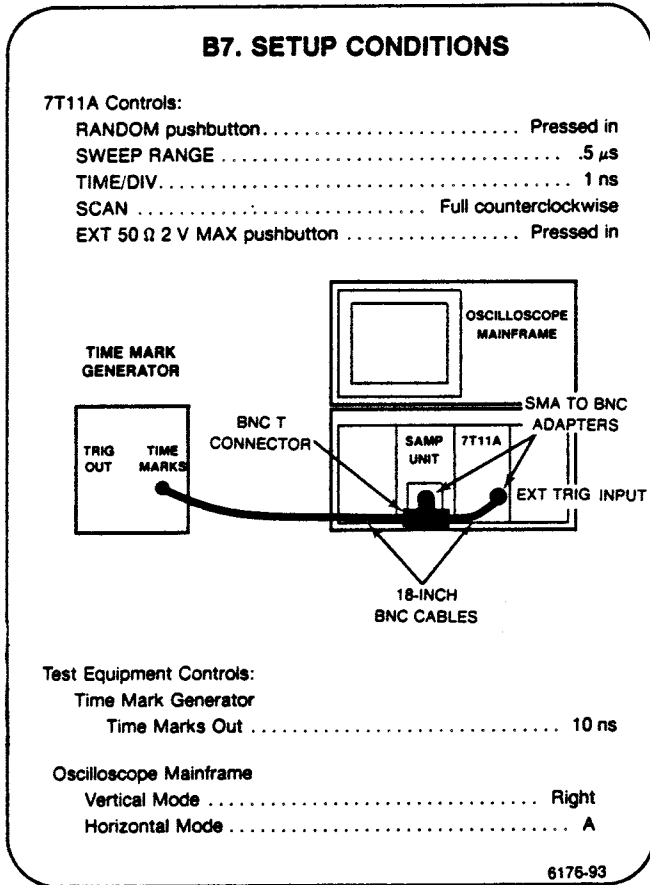

a. Set 7T11A TRIG LEVEL to stabilize the display as much as possible.

**NOTE**

*These values are provided only as examples of typical instrument operation. They are not to be considered specifications.*

b. **EXAMINE**—the display for momentary pulling or tugging to the left (usually less than a division) which has a slow repetitive cycle (about a second).

**B8. CHECK REPETITIVE SCAN RATE**

**NOTE**

If the previous step was not performed, first perform step B1.

**B8. SETUP CONDITIONS**

7T11A Controls:  
 SCAN ..... Full clockwise  
 SWEEP RANGE ..... 50  $\mu$ s  
 TIME/DIV ..... 5  $\mu$ s

1X PROBE

Test Equipment Controls:  
 Oscilloscope Mainframe  
 Vertical Mode ..... Left  
 Horizontal Mode ..... B  
 Differential Comparator  
 Volts/Div ..... 5  
 +Input ..... DC  
 -Input ..... GND  
 Time Base  
 Time/Div ..... 5 ms

6176-99

- a. **CHECK**—the display for 25 ms or less per sawtooth (see Figure 5-11).
- b. Set the Time Base Time/Div to .1 s and set 7T11A SCAN to full counterclockwise.
- c. **CHECK**—the display for 500 ms or more per sawtooth.

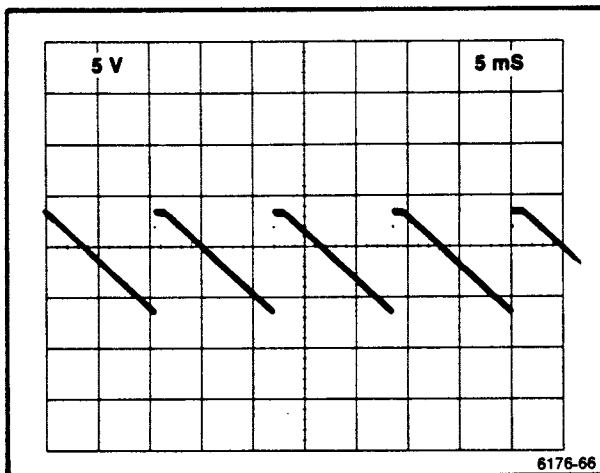

Figure 5-11. Sweep Out waveform to check Repetitive Scan rate.

**B9. CHECK SWEEP OUT**

**NOTE**

If the previous step was not performed, first perform step B1.

**B9. SETUP CONDITIONS**

7T11A Controls:  
 No change from previous step.

1X PROBE

Test Equipment Controls:  
 Time Base  
 Triggering ..... Auto, AC, Int  
 Time/Div ..... .5 ms  
 Differential Comparator  
 Volts/Div ..... 2  
 +Input ..... GND

6176-100

- a. Use the Differential Comparator Position control to center the sweep on the display.
- b. Set the Differential Comparator +Input to DC.
- c. Press in the 7T11A MAN pushbutton.
- d. **CHECK**—the displayed sweep to be at least +5 volts with SCAN full counterclockwise and at least -5 volts with SCAN full clockwise.

**Checks and Adjustment—7T11A**  
**Part II—Performance Check and Adjustment**

**B10. EXAMINE/ADJUST SYNC COUNTDOWN (A3R30)**

**NOTE**

*If the previous step was not performed, first perform step B1.*

c. **ADJUST**—Sync Countdown adjustment R30 for a 10 MHz repetition rate on the oscilloscope display.

d. **INTERACTION**—Adjustments described in this subsection may interact with other related circuits. If any adjustment is made, it is recommended that the remainder of this procedure subsection be performed and the entire subsection repeated.

**B10. SETUP CONDITIONS**

**7T11A Controls:**

- EXT HF SYNC pushbutton ..... Pressed in
- TRIG LEVEL ..... Full counterclockwise
- STABILITY ..... Full counterclockwise

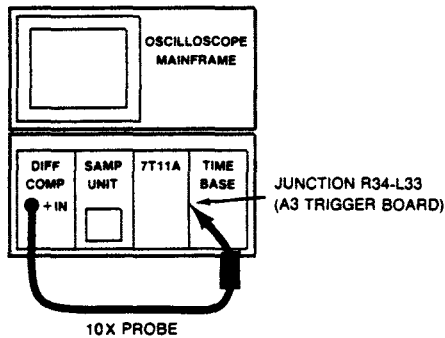

**Test Equipment Controls:**

- Differential Comparator**
- Volts/Div ..... 20 mV
- BW ..... Full
- +Input ..... DC
- Input ..... GND
- Time Base**
- Triggering ..... Auto, AC, Int
- Time/Div ..... .05  $\mu$ s
- Oscilloscope Mainframe**
- Vertical Mode ..... Left
- Horizontal Mode ..... B

6176-101

a. Set the Differential Comparator Position control and Time Base Position and Triggering controls for a stable display as shown in Figure 5-12A.

**NOTE**

*These values are provided only as examples of typical instrument operation. They are not to be considered specifications.*

b. **EXAMINE**—the display for a pulse repetition rate of 10 MHz within 5 MHz (see Figure 5-12A).

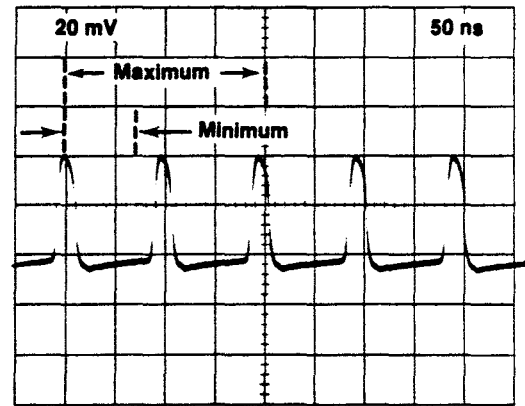

**A. Test oscilloscope display for Sync Countdown R30 adjustment.**

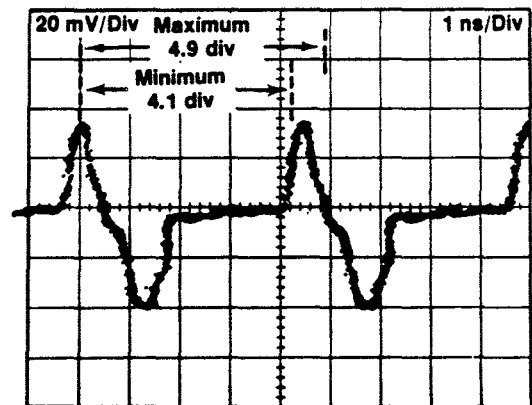

**B. Trigger kickout in RANDOM mode for HF Sync R10 adjustment, TRIG LEVEL and STABILITY controls fully counterclockwise.**

6176-67

**Figure 5-12. Typical display for HF Sync adjustments.**



**B11. EXAMINE/ADJUST HF SYNC KICKOUT  
(A3R10, A3R30)**

**NOTE**

*If the previous step was not performed, first perform step B1.*

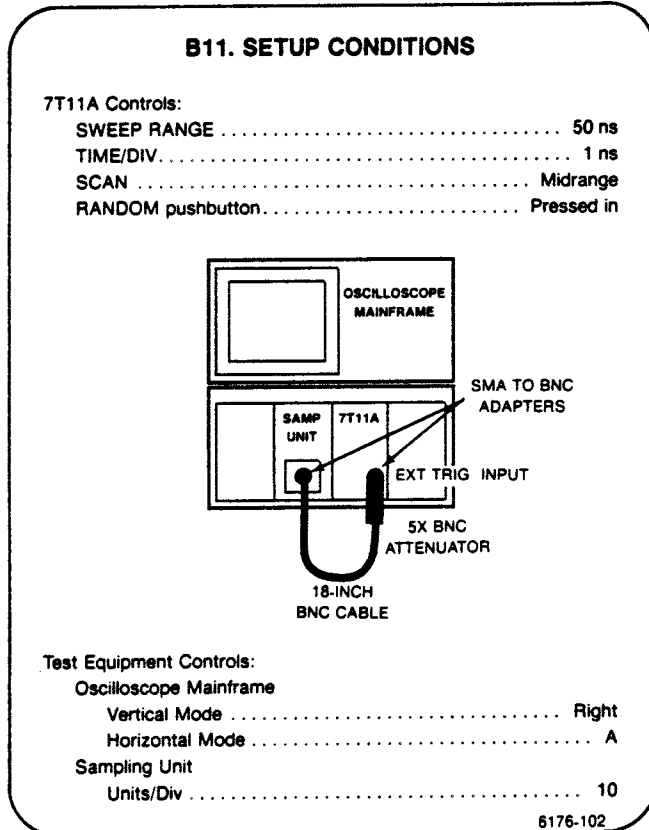

a. Set 7T11A TRIG LEVEL and STABILITY to full counterclockwise.

**NOTE**

*These values are provided only as examples of typical instrument operation. They are not to be considered specifications.*

b. **EXAMINE**—the display for the period between kickout pulses to be between 4.9 ns and 4.1 ns (205 MHz to 245 MHz). See Figure 5-12B for a typical display.

c. Set 7T11A TRIG LEVEL and STABILITY to full clockwise.

d. **EXAMINE**—the display for the period between kickout pulses to be 80% or less of what was measured in part b.

e. **ADJUST**—HF Sync adjustment R10 for correct operation as described in parts a through d.

f. Set 7T11A TIME/DIV to 5 ns, TIME POSITION to full clockwise, and the SEQUENTIAL pushbutton pressed in.

g. **EXAMINE**—the display for no kickout to be visible after the first 5 divisions of sweep while rotating TRIG LEVEL and STABILITY throughout their range.

h. **INTERACTION**—Adjustments described in this subsection may interact with other related circuits. If any adjustment is made, it is recommended that the remainder of this procedure subsection be performed and the entire subsection repeated.

**Checks and Adjustment—7T11A**  
**Part II—Performance Check and Adjustment**

**B12. CHECK EXT INPUT**

**NOTE**

*If the previous step was not performed, first perform step B1.*

**B12. SETUP CONDITIONS**

7T11A Controls:

MAN pushbutton .....	Pressed in
SEQUENTIAL pushbutton .....	Pressed in
SCAN .....	Full clockwise
SWEEP RANGE .....	50 $\mu$ s
TIME/DIV .....	5 $\mu$ s

The diagram shows two pieces of equipment. The top one is labeled 'OSCILLOSCOPE MAINFRAME'. Below it is the 'SAMP UNIT' (Sampling Unit) which has an 'OFFSET OUT' terminal. To the right of the SAMP UNIT is the '7T11A' unit with an 'EXT INPUT' terminal. A 'PATCH CORD' is shown connecting the 'OFFSET OUT' terminal of the SAMP UNIT to the 'EXT INPUT' terminal of the 7T11A unit.

Test Equipment Controls:

Oscilloscope Mainframe	
Vertical Mode .....	Left
Horizontal Mode .....	A
Sampling Unit	
Units/Div .....	200
Cal/Variable .....	Variable
Variable .....	Full counterclockwise

6176-103

- a. **EXAMINE**—the display for a dot near the right graticule edge.
  
- b. Press in the 7T11A EXT INPUT pushbutton. Connect the Sampling Unit Offset Out to 7T11A EXT INPUT 1 V/DIV 100 k $\Omega$  with a patch cord.
  
- c. Set Sampling Unit Offset to position the dot at the right edge of the graticule.
  
- d. **CHECK**—that the dot moves to the left graticule edge when 7T11A SCAN is set to full counterclockwise.

## C. TRIGGER OPERATION

### Equipment Required:

- |   |  |
|---|--|
| 1. Oscilloscope Mainframe               | 15. BSM to BNC cable                   |
| 2. Sampling Unit                        | 16. GR Power Divider                   |
| 3. Sampling Head                        | 17. SMA Power Divider                  |
| 4. Low Frequency Sine Wave Generator    | 18. BNC T Connector                    |
| 5. Medium Frequency Sine Wave Generator | 19. SMA to BNC Adapter (2 required)    |
| 6. High Frequency Sine Wave Generator   | 20. 10X BNC Attenuator                 |
| 7. SHF Signal Generator                 | 21. 5X BNC Attenuator                  |
| 8. Pulse Generator                      | 22. 2X SMA Attenuator                  |
| 9. Differential Comparator              | 23. 18-Inch BNC Cable (2 required)     |
| 10. Time Base Plug-In                   | 24. 50 $\Omega$ SMA Cable (2 required) |
| 11. Time Mark Generator                 | 25. 50 $\Omega$ BNC Cable              |
| 12. 50 $\Omega$ Delay Line              | 26. 50 $\Omega$ BNC Termination        |
| 13. Plug-In Extender                    | 27. SMA to GR Adapter (2 required)     |
| 14. Special RF cable assembly           | 28. GR to BNC Adapter (4 required)     |
|   | 29. GR T Connector                     |

### BEFORE YOU BEGIN:

(1) Perform the Performance Check and Adjustment Power Up Sequence.

(2) Refer to section 6, Instrument Options, and the Change Information section at the rear of this manual for any modifications that may affect this procedure.

(3) See the **TEST POINT AND ADJUSTMENT LOCATIONS** foldout page in section 8, Diagrams and Circuit Board Illustrations.

### NOTE

*The 7T11A SWEEP RANGE control and TIME POS RNG window are integral features. In this procedure, SWEEP RANGE settings are indicated by the value displayed in the TIME POS RNG window.*

### C1. TRIGGER OPERATION PRELIMINARY CONTROL SETTINGS

#### 7T11A

TIME POSITION ..... Midrange  
 SLOPE ..... (+)

#### Sampling Unit

Polarity ..... +Up  
 Normal/Smooth ..... Normal

#### Oscilloscope Mainframe

Vertical Mode ..... Right  
 Horizontal Mode ..... A

Checks and Adjustment—7T11A  
Part II—Performance Check and Adjustment

**C2. CHECK LOW-FREQUENCY TRIGGERING**

**NOTE**

First perform step C1, then proceed.

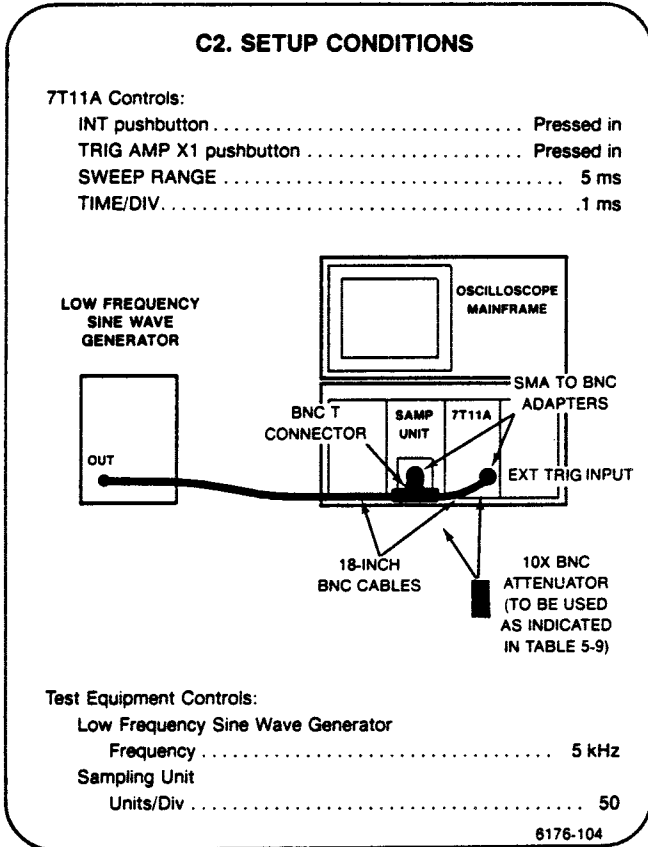

a. **CHECK**—7T11A low-frequency triggering capability by using the control settings and requirements given in Table 5-9 to obtain a stable, triggered display. The signal generator output amplitude is correct when its signal causes the amount of vertical deflection shown under the display size column. Add a 10X BNC Attenuator to the 7T11A trigger signal as indicated in the right-hand column of Table 5-9. Set 7T11A STABILIZ and TRIG LEVEL as necessary for a stable display. On real-time ranges, TIME POSITION also aids in stabilizing triggering. Changes in control settings between successive steps are indicated in the table with an asterisk.

**NOTE**

To check internal triggering from the mainframe's other vertical compartment, an additional Sampling Unit may be installed and the internal triggering steps repeated for that compartment.

**C3. CHECK MEDIUM-FREQUENCY TRIGGERING**

**NOTE**

If the previous step was not performed, first perform step C1.

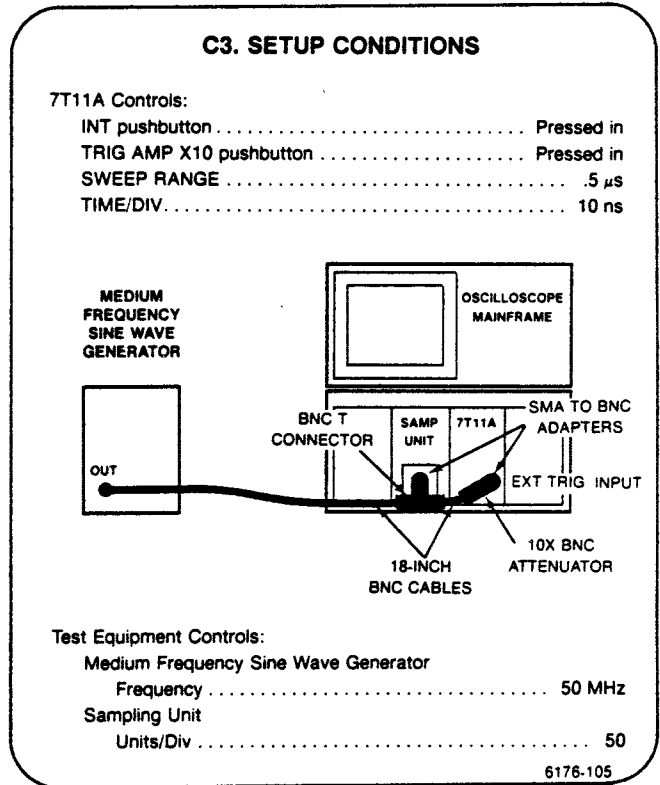

a. **CHECK**—7T11A medium-frequency triggering capability by using the control settings and requirements given in Table 5-10 to obtain a stable, triggered display. The signal generator output amplitude is correct when its signal causes the amount of vertical deflection shown under the Display Size column. Set 7T11A STABILIZ and TRIG LEVEL as necessary for a stable display. Add a 10X BNC Attenuator to the 7T11A trigger signal as indicated in the right-hand column of Table 5-10. Changes in control settings between successive steps are indicated in the table with an asterisk.

TABLE 5-9  
Low-Frequency Triggering

TRIGGERING MODE	SAMPLING UNIT UNITS/DIV	7T11A				GENERATOR FREQUENCY	GENERATOR OUTPUT	DISPLAY SIZE	10X ATTENUATOR
		SWEEP RANGE	TIME/DIV	TRIG AMP	TRIG MODE				
INTERNAL	50	5 ms	.1 ms	X1	INT	5 kHz	125 mV	2.5 div	NONE
INTERNAL	5*	5 ms	.1 ms	X10*	INT	5 kHz	12.5 mV	2.5 div	NONE
INTERNAL	200*	5 ms	.1 ms	X10	INT	5 kHz	1 V	5 div	NONE
EXTERNAL	5*	5 ms	.5 ms*	X10	EXT 50 Ω*	1 kHz*	12.5 mV	2.5 div	TRIGGER SIGNAL
EXTERNAL	5	5 ms	.5 ms	X10	EXT 1 MΩ*	1 kHz	12.5 mV	2.5 div	TRIGGER SIGNAL
EXTERNAL	50*	50 ms*	5 ms*	X1*	EXT 1 MΩ	50 Hz*	125 mV	2.5 div	TRIGGER SIGNAL
EXTERNAL	5*	50 ms	5 ms	X1	EXT 50 Ω*	50 Hz	12.5 mV	2.5 div	TRIGGER SIGNAL

TABLE 5-10  
Medium-Frequency Triggering

TRIGGERING MODE	SAMPLING UNIT UNITS/DIV	7T11A				GENERATOR FREQUENCY	GENERATOR OUTPUT	DISPLAY SIZE	10X ATTENUATOR
		SWEEP RANGE	TIME/DIV	TRIG AMP	TRIG MODE				
INTERNAL	50	.5 μs	10 ns	X10	INT	50 MHz	125 mV	2.5 div	TRIGGER SIGNAL
EXTERNAL	5*	.5 μs	10 ns	X10	EXT 50 Ω*	50 MHz	12.5 mV	2.5 div	TRIGGER SIGNAL
EXTERNAL	5	.5 μs	10 ns	X10	EXT 1 MΩ*	50 MHz	12.5 mV	2.5 div	TRIGGER SIGNAL
EXTERNAL	50*	.5 μs	10 ns	X1*	EXT 1 MΩ	100 MHz*	125 mV	2.5 div	TRIGGER SIGNAL

TABLE 5-11  
High-Frequency Triggering

TRIGGERING MODE	SAMPLING UNIT UNITS/DIV	7T11A				GENERATOR FREQUENCY	GENERATOR OUTPUT	DISPLAY SIZE	ATTENUATION
		SWEEP RANGE	TIME/DIV	TRIG AMP	TRIG MODE				
INTERNAL	50	50 ns	1 ns	X1	INT	500 MHz	125 mV	2.5 div	10X AT SIGNAL INPUT
EXTERNAL	100*	50 ns	.5 ns*	X1	EXT 50 Ω*	1 GHz*	625 mV	6.25 div	5X + 10X AT TRIGGER INPUT
EXT HF SYNC	100	50 ns	.5 ns	X1	EXT HF SYNC*	1 GHz	500 mV	5 div	10X AT TRIGGER INPUT
EXT HF SYNC	100	50 ns	.5 ns	X1	EXT HF SYNC	1 GHz	500 mV	5 div	NONE

**Checks and Adjustment—7T11A**  
**Part II—Performance Check and Adjustment**

**C4. CHECK HIGH-FREQUENCY TRIGGERING**

**NOTE**

*If the previous step was not performed, first perform step C1.*

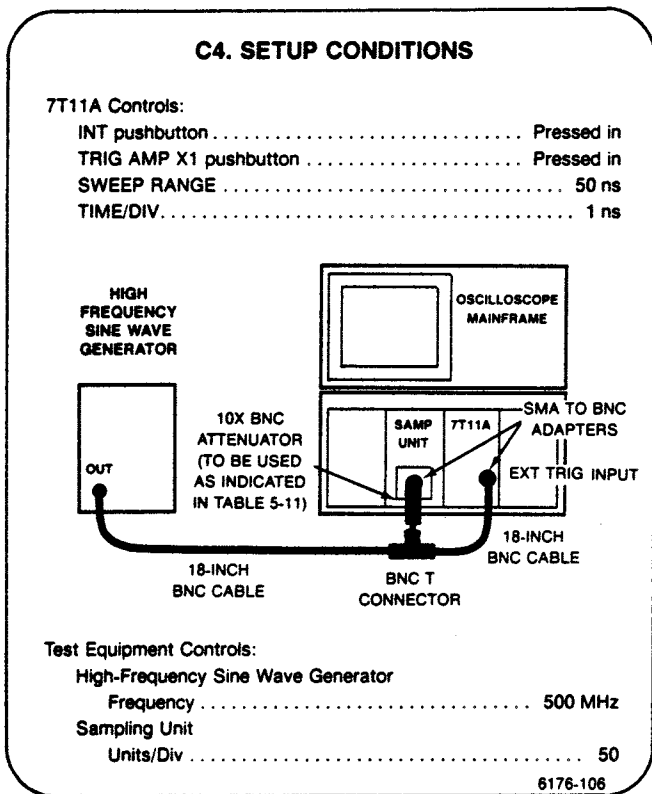

a. **CHECK**—7T11A high-frequency triggering capability by using the control settings and requirements given in Table 5-11 to obtain a stable, triggered display. The signal generator output amplitude is correct when its signal causes the amount of vertical deflection shown under the Display Size column. Set 7T11A STABILITY and TRIG LEVEL as necessary for a stable display. Add BNC Attenuators to the 7T11A trigger input signal or Sampling Unit signal input as indicated in the right-hand column of Table 5-11. Changes in control settings between successive steps are indicated in the table with an asterisk.

**C5. CHECK 12.4 GHz HF SYNC TRIGGERING**

**NOTE**

*If the previous step was not performed, first perform step C1.*

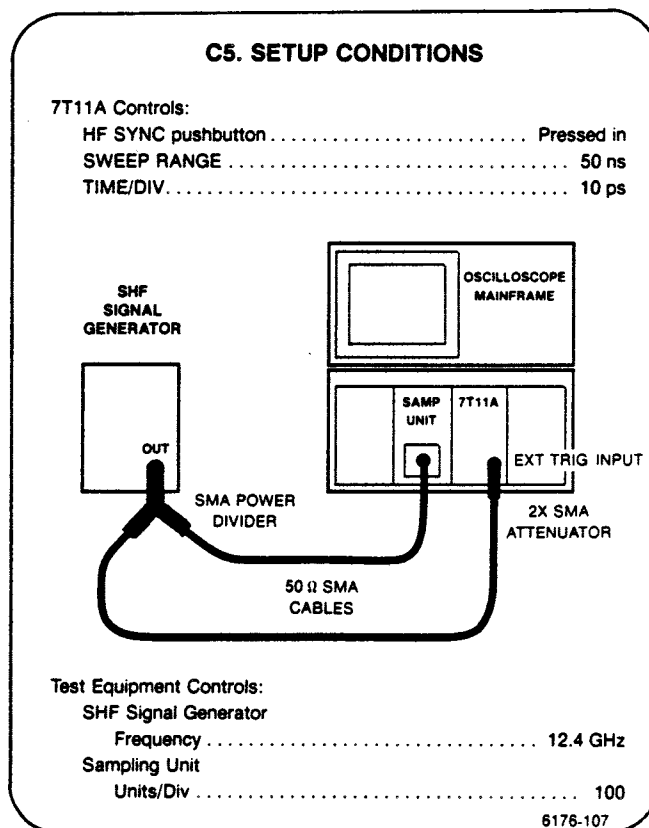

a. **CHECK**—that a stable, triggered waveform providing 200 mV of trigger signal to the 7T11A can be obtained on the oscilloscope display by using the 7T11A STABILITY and TRIG LEVEL controls along with the signal generator Amplitude control.

b. Set the Sampling Unit Units/Div to 200 mV/Div.

c. **CHECK**—that a stable, triggered waveform providing 500 mV of trigger signal to the 7T11A can be obtained on the oscilloscope display by using the 7T11A STABILITY and TRIG LEVEL controls along with the signal generator Amplitude control.

**C6. CHECK SEQUENTIAL-MODE DISPLAY JITTER AT FASTEST SWEEP RANGE POSITION**

**NOTE**

If the previous step was not performed, first perform step C1.

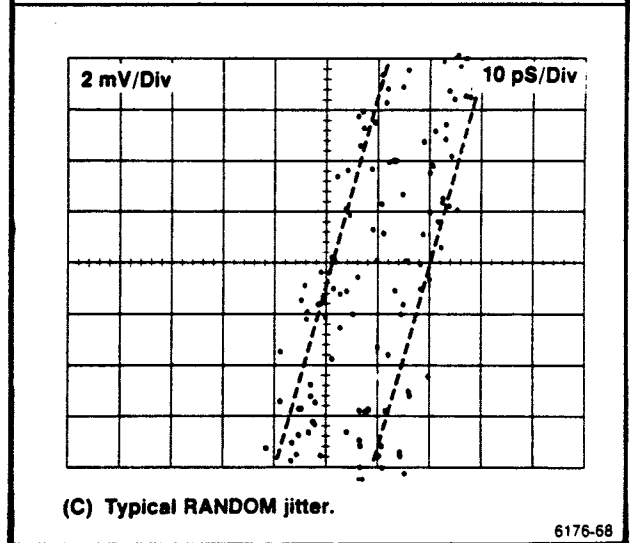
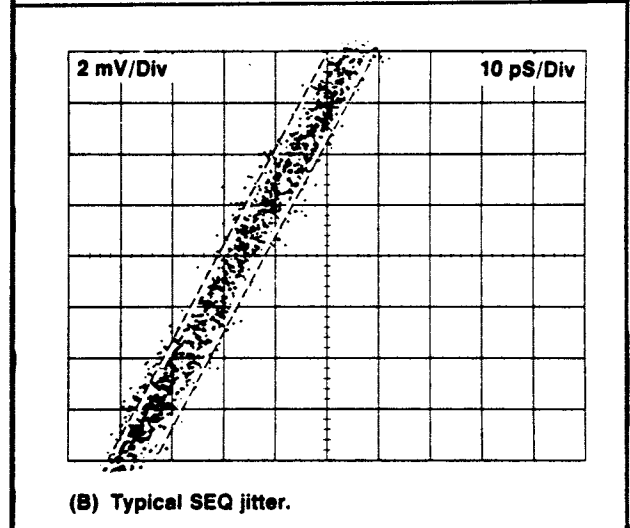
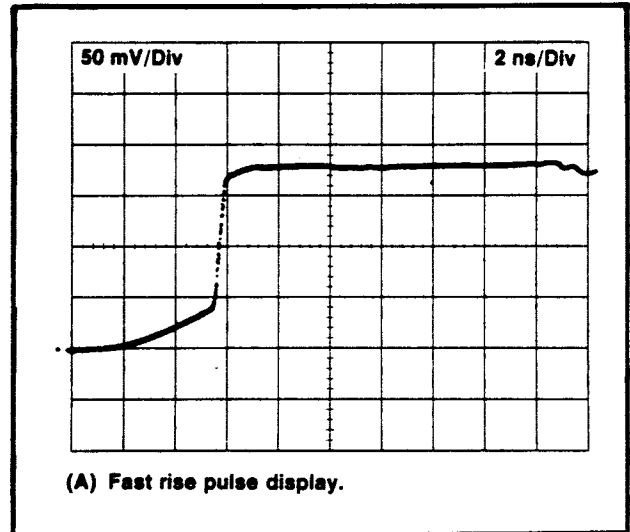
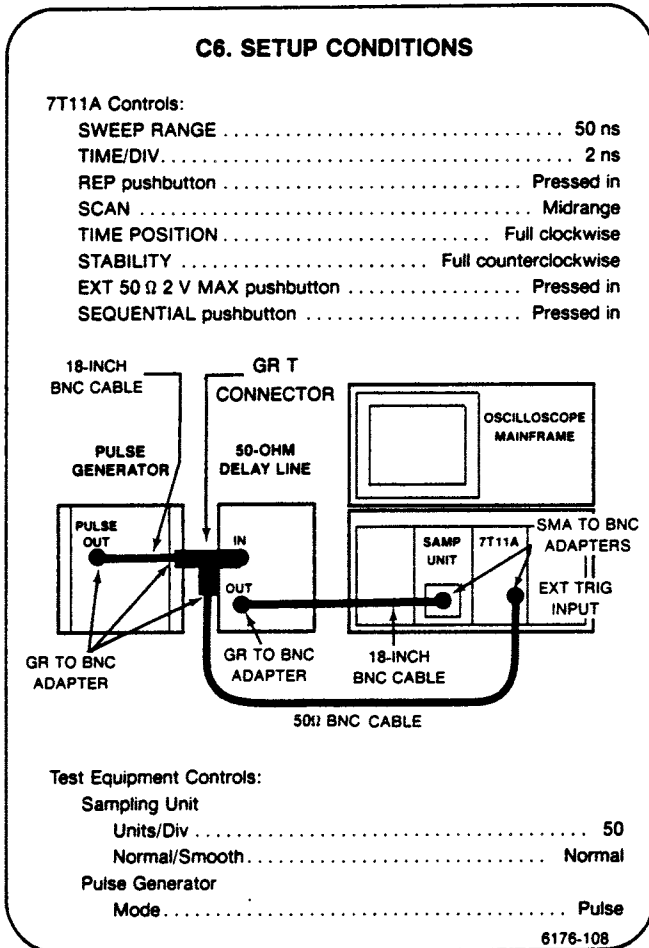

- a. Set 7T11A TRIG LEVEL, if necessary, for a display such as that shown in Figure 5-13A.
- b. Rotate the TIME/DIV control clockwise to .2 ns, one step at a time, while using TIME POSITION, STABILITY, and TRIG LEVEL to maintain best possible display stability of the pulse leading edge.
- c. Set the Sampling Unit Units/Div to 2 and use the Sampling Unit DC Offset and 7T11A TIME POSITION to keep the pulse leading edge visible.

Figure 5-13. Determining display jitter.

**Checks and Adjustment—7T11A**  
**Part II—Performance Check and Adjustment**

d. While maintaining best possible display stability, rotate TIME/DIV to the 10 ps position.

e. **CHECK**—the oscilloscope display for less than 10 ps of jitter, as shown in Figure 5-13B.

**NOTE**

*If display jitter exceeds the specified 10 ps value, the cause may be excessive trigger jitter or jitter by other circuits in the sampling system. The procedure of step C10 removes the trigger portion of display jitter, and is therefore a troubleshooting aid.*

**C7. CHECK RANDOM-MODE DISPLAY JITTER AT FASTEST SWEEP RANGE POSITION**

**NOTE**

*If the previous step was not performed, first perform step C1.*

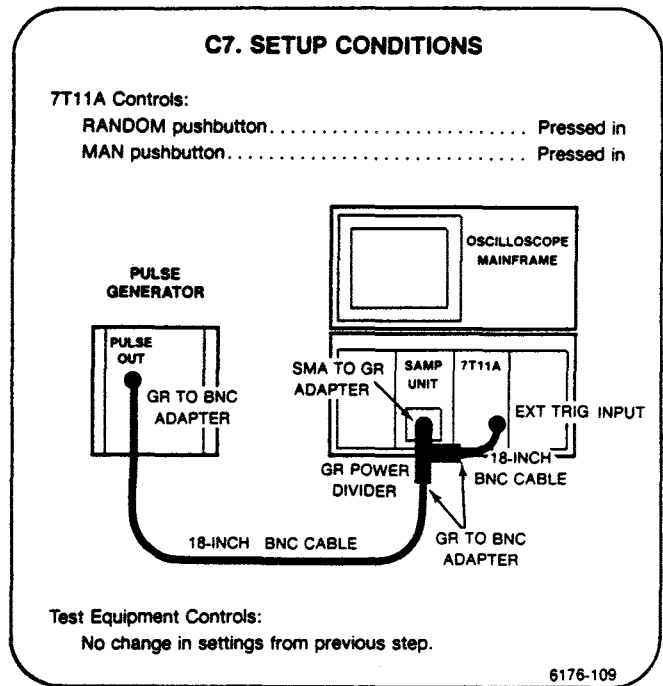

a. Set 7T11A TRIG LEVEL, if necessary, for a display such as that shown in Figure 5-13A.

b. Rotate the TIME/DIV control clockwise to .2 ns, one step at a time, while using TIME POSITION, STABILITY, and TRIG LEVEL to maintain best possible display stability of the pulse leading edge.

c. Set the Sampling Unit Units/Div to 2 and use the Sampling Unit DC Offset and 7T11A TIME POSITION to keep the pulse leading edge visible.

d. While maintaining best possible display stability, rotate TIME/DIV to the 10 ps position.

e. **CHECK**—the oscilloscope display for less than 30 ps of jitter, as shown in Figure 5-13C.

**NOTE**

*If display jitter exceeds the specified 30 ps value, the cause may be excessive trigger jitter or jitter by other circuits in the sampling system. The procedure of step C10 removes the trigger portion of display jitter, and is therefore a troubleshooting aid.*



**C8. CHECK DISPLAY JITTER AT REMAINING SWEEP RANGE POSITIONS**

**NOTE**

If the previous step was not performed, first perform step C1.

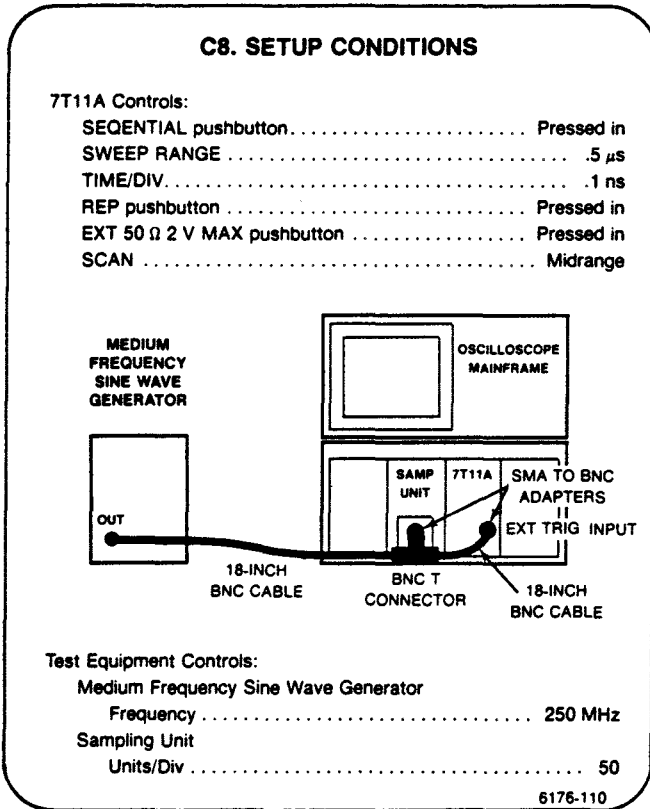

a. Set 7T11A TRIG LEVEL and STABILITY, Sampling Unit Offset, and signal generator Amplitude for an 8-division sine wave display.

b. Set 7T11A TIME/DIV to .1 ns and TIME POSITION to view a sine wave leading edge.

c. **CHECK**—the oscilloscope display for jitter using the settings and requirements given in Table 5-12(A). Carefully adjust 7T11A STABILITY and TRIG LEVEL for minimum jitter before measurement is made. Press the 7T11A REP pushbutton in when checking Sequential mode operation and the MAN pushbutton in when checking Random mode.

**NOTE**

If display jitter exceeds the specified value, the cause may be excessive trigger jitter or jitter by other circuits in the sampling system. The procedure of step C10 removes the trigger portion of display jitter, and is therefore a troubleshooting aid.

d. Disconnect the Medium Frequency Sine Wave Generator and connect the Low Frequency Sine Wave Generator in its place.

e. **CHECK**—the oscilloscope display for jitter using the settings and requirements given in Table 5-12(B). Carefully adjust 7T11A STABILITY and TRIG LEVEL for minimum jitter before measurement is made.

**TABLE 5-12**  
**Display Jitter with Optimum Trigger Conditions**

7T11A				GENERATOR FREQUENCY	DISPLAY JITTER
SCAN MODE	SAMPLING MODE	SWEEP RANGE	TIME/DIV		

(A) SEQUENTIAL AND RANDOM OPERATOR

REP	SEQUENTIAL	.5 $\mu$ s	.1 ns	250 MHz	$\leq 0.4$ division
REP		5 $\mu$ s	1 ns	75 MHz	
REP		50 $\mu$ s	10 ns	7.5 MHz	
MAN	RANDOM	.5 $\mu$ s	.1 ns	250 MHz	$\leq 1$ division
MAN		5 $\mu$ s	1 ns	75 MHz	
MAN		50 $\mu$ s	10 ns	7.5 MHz	

(B) REAL TIME OPERATION

REP	REAL TIME	.5 ms	.1 $\mu$ s	350 kHz	$\leq 0.4$ division
REP		5 ms	1 $\mu$ s	50 kHz	
REP		50 ms	10 $\mu$ s	5 kHz	

**Checks and Adjustment—7T11A**  
**Part II—Performance Check and Adjustment**

**C9. CHECK HF SYNC DISPLAY JITTER**

**NOTE**

*If the previous step was not performed, first perform step C1.*

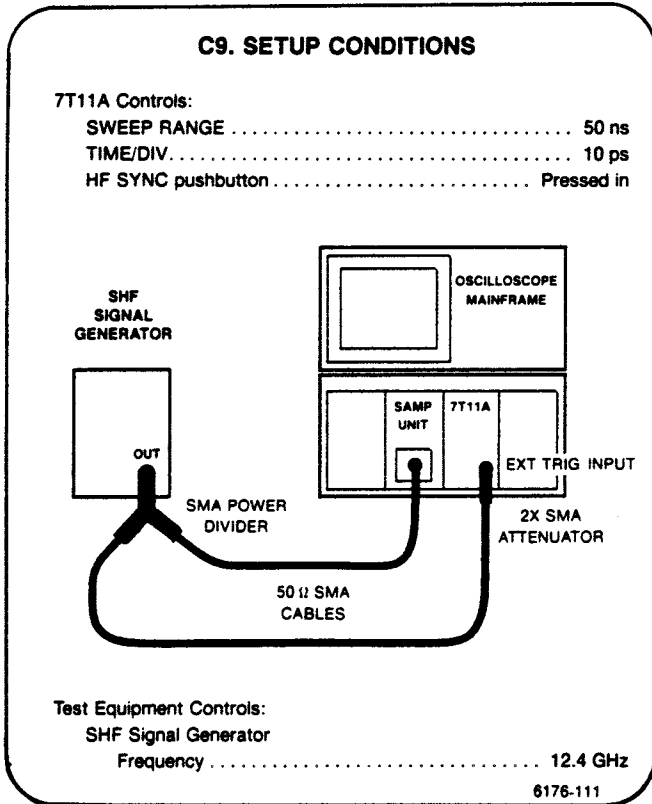

a. Set the Generator Amplitude and Sampling Unit Units/Div controls to provide at least 200 mV of trigger signal to the 7T11A and display a steep enough waveform slope to accurately measure jitter.

b. **CHECK**—for 20 ps or less of display jitter.

**NOTE**

*If display jitter exceeds the specified value, the cause may be excessive trigger jitter or jitter by other circuits in the sampling system. The procedure of step C10 removes the trigger portion of display jitter, and is therefore a troubleshooting aid.*

**C10. EXAMINE DISPLAY JITTER NOT DUE TO TRIGGERING**

**NOTE**

*This step need not be performed if the requirements of steps C6, C7, C8, and C9 are met. This procedure provides a means of removing jitter caused by triggering circuits from the display. This step can therefore be considered a troubleshooting aid for determining whether excessive jitter measured in any of steps C6 through C9 is due to triggering or other circuits.*

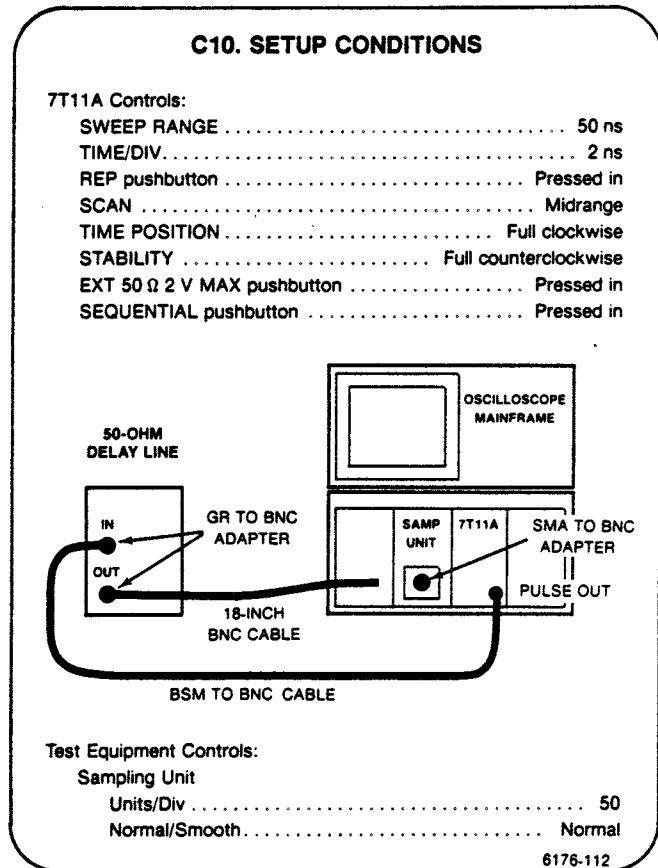

a. Obtain a free-running sweep by setting 7T11A STABILITY full clockwise and TRIG LEVEL to approximately midrange.

b. Connect 7T11A PULSE OUT through a 50 delay line to the Sampling Head input.

c. Set 7T11A TRIG LEVEL, STABILITY and TIME POSITION, along with Sampling Unit Offset to display the pulse leading edge.

d. Set the Sampling Unit Units/Div to 2.

e. Rotate 7T11A TIME/DIV clockwise to the 10 ps position while using TIME POSITION, STABILITY and TRIG LEVEL to keep the leading edge displayed.

f. **EXAMINE**—the display for jitter. The amount measured with this method is due to other circuits than those used for triggering.

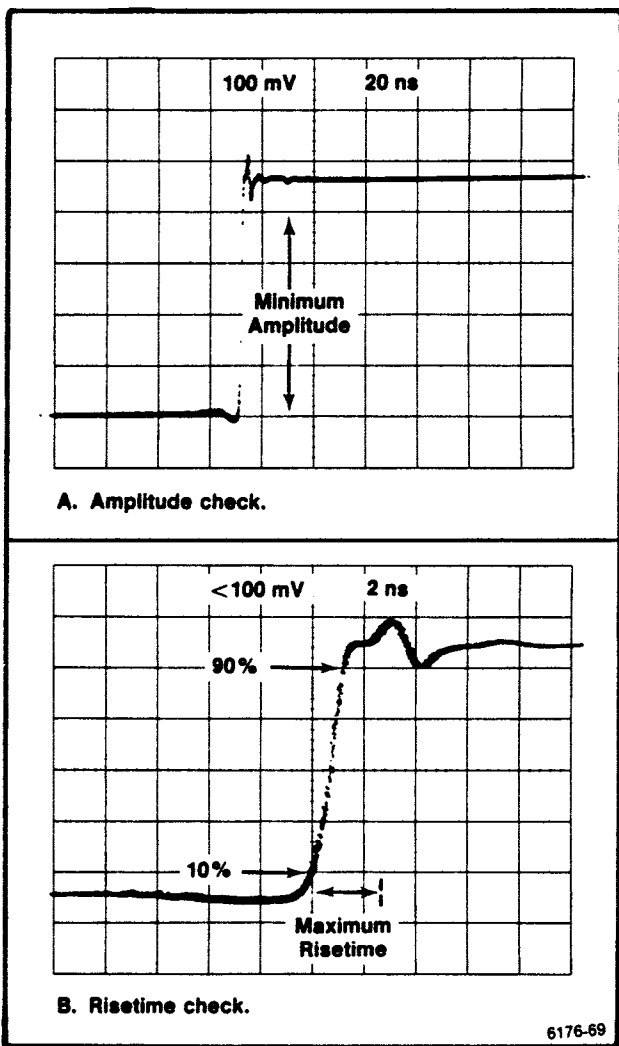

Figure 5-14. Typical display of the Pulse Out waveform.

**C11. CHECK PULSE OUT INTO 50 Ω**

**NOTE**

If step C9 was not performed, first perform step C1.

**C11. SETUP CONDITIONS**

7T11A Controls:

TIME POSITION .....	Full clockwise
SLOPE .....	(+)
TRIG LEVEL .....	Midrange
STABILITY .....	Full clockwise
RANDOM pushbutton .....	Pressed in
TRIG AMP X1 pushbutton .....	Pressed in
SWEEP RANGE .....	5 μs
TIME/DIV .....	20 ns
INT pushbutton .....	Pressed in
REP pushbutton .....	Pressed in

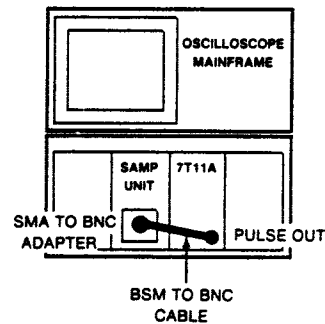

Test Equipment Controls:

Sampling Unit	
+ Up pushbutton .....	Pressed in
DC Offset .....	Centered display
Units/Div .....	100
Normal/Smooth .....	Normal

6176-113

a. Rotate 7T11A TIME POSITION counterclockwise to display the rising portion of the pulse.

b. **CHECK**—the display for at least 400 mV of signal amplitude (see Figure 5-14A).

c. Set TIME/DIV for 2 ns and Sampling Unit Variable for 5 divisions of amplitude at the rising portion.

d. **CHECK**—risetime to be 2.5 ns or less as measured between the 10% and 90% amplitude points on the rising portion (center four divisions; see Figure 5-14B).

e. Push the Sampling Unit Variable control back in.

**Checks and Adjustment—7T11A**  
**Part II—Performance Check and Adjustment**

**C12. CHECK TRIGGER KICK OUT**

**NOTE**

If the previous step was not performed, first perform step C1.

**C12. SETUP CONDITIONS**

7T11A Controls:

TIME POSITION .....	Full clockwise
FINE .....	Full clockwise
SWEEP RANGE .....	50 ns
TIME/DIV .....	5 ns
INT pushbutton .....	Pressed in

Test Equipment Controls:

Sampling Unit	
Normal/Smooth .....	Smooth
Units/Div .....	2
DC Offset .....	Midrange

6176-114

a. Install a Sampling Head having less than 2 mV of display noise in the Sampling Unit. Connect the Sampling Head input to the 7T11A EXT TRIG INPUT.

b. Set Sampling Unit DC Offset to position the trace at graticule center.

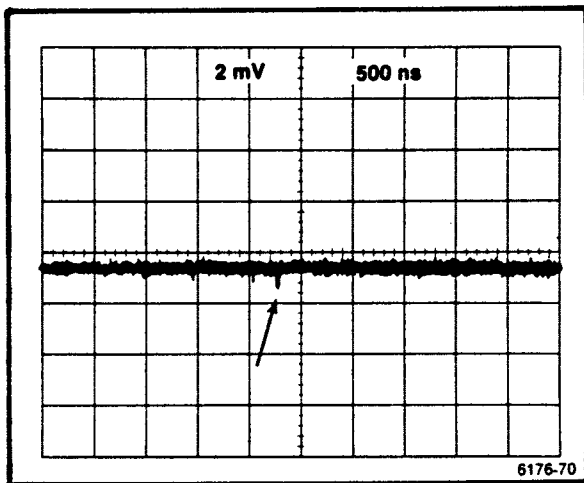

Figure 5-15. Typical display of trigger kickout.

c. **CHECK**—the trigger kickout pulse to be no more than  $\pm 2$  mV (see Figure 5-15).

d. Replace the Sampling Head with the one previously used.

**C13. EXAMINE TRIGGER HOLDOFF**

**NOTE**

If the previous step was not performed, first perform step C1.

**C13. SETUP CONDITIONS**

7T11A Controls:

SWEEP RANGE .....	50 ns
-------------------	-------

Test Equipment Controls:

Differential Comparator	
+ Input .....	DC
Volts/Div .....	.2
-Input .....	GND
Bandwidth .....	Full
Time Base	
Triggering .....	Auto, AC, Int
Time/Div .....	10 $\mu$ s
Level and Slope .....	Stable display
Oscilloscope Mainframe	
Vertical Mode .....	Left
Horizontal Mode .....	B
Sampling Unit	
Normal/Smooth .....	Normal

6176-115

a. **EXAMINE**—the oscilloscope display to determine the trigger holdoff time. Use the settings and holdoff values given in Table 5-13 (see Figure 5-16 for a holdoff measurement example).

NOTE

These values are provided only as an example of typical instrument operation. They are not to be considered specifications.

TABLE 5-13  
Trigger Holdoff

7T11A SWEEP RANGE	TIME BASE TIME/DIV	TRIGGER HOLDOFF
50 ns	10 $\mu$ s	$\geq 25 \mu$ s
.5 $\mu$ s		
5 $\mu$ s		
50 $\mu$ s	50 $\mu$ s	$\geq 200 \mu$ s
.5 ms	.5 ms	> 1.5 ms
5 ms	.5 ms	
50 ms	2 ms	

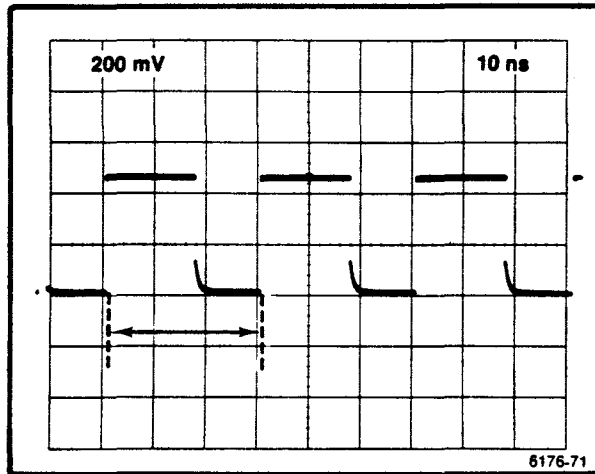

Figure 5-16. Trigger holdoff measurement.

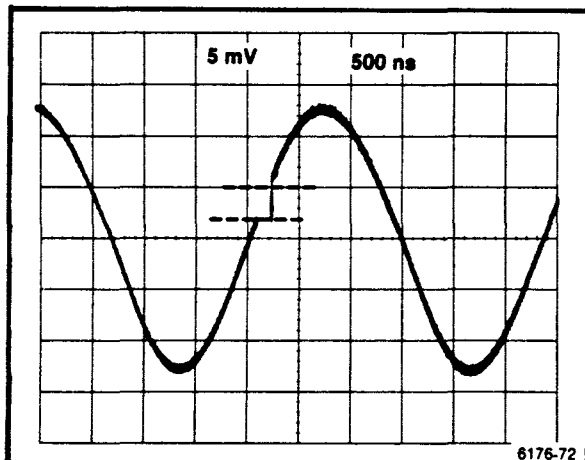

Figure 5-17. Typical display of strobe kickback.

C14. EXAMINE STROBE KICKBACK INTO TRIGGER

NOTE

If the previous step was not performed, first perform step C1.

C14. SETUP CONDITIONS

7T11A Controls:

SWEEP RANGE ..... 5  $\mu$ s  
 TIME/DIV ..... .5  $\mu$ s  
 TIME POSITION ..... Full clockwise  
 FINE ..... Full clockwise  
 EXT 50  $\Omega$  2 V MAX pushbutton ..... Pressed in  
 STABILITY ..... Full counterclockwise

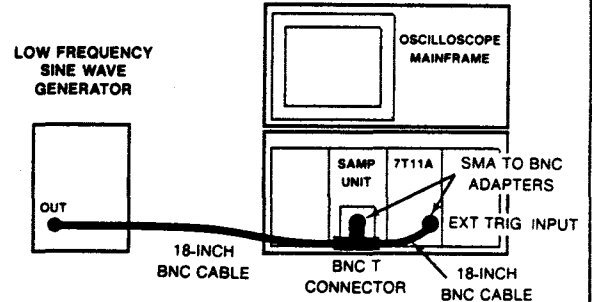

Test Equipment Controls:

Leveled Sine-wave Generator  
 Frequency ..... 350 kHz  
 Oscilloscope Mainframe  
 Vertical Mode ..... Right  
 Horizontal Mode ..... A  
 Sampling Unit  
 Units/Div ..... 5

6176-116

a. Set the Sine Wave Generator amplitude and 7T11A TRIG LEVEL for a stable display with 5 divisions of amplitude.

b. **EXAMINE**—the displayed waveform for any discontinuity to be a maximum of 2 major divisions (2 mV or less; see Figure 5-17).

NOTE

This value is provided only as an example of typical instrument operation. It is not to be considered a specification.

**Checks and Adjustment—7T11A**  
**Part II—Performance Check and Adjustment**

**C15. CHECK MINIMUM TRIGGER RATE IN  
RANDOM MODE**

**NOTE**

*If the previous step was not performed, first perform step C1.*

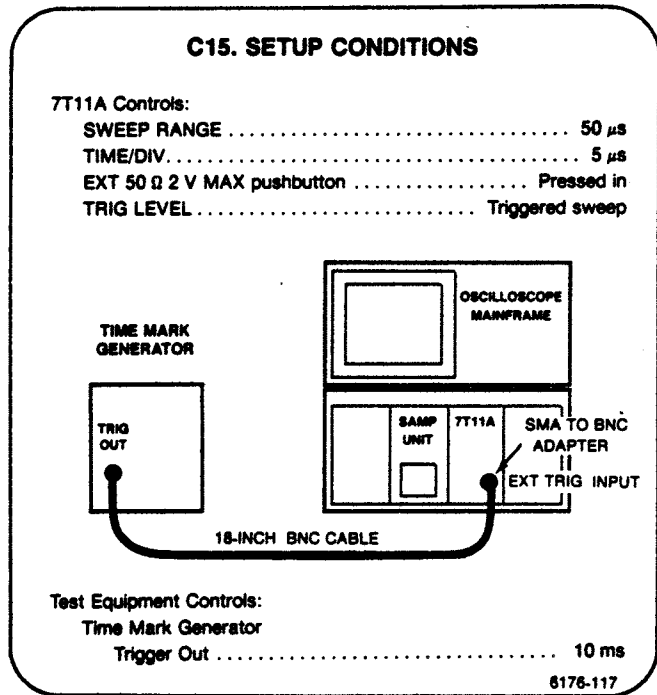

- a. Set 7T11A TRIG LEVEL for a triggered sweep.
- b. **CHECK**—for the displayed sweep length to be at least 9 divisions.

This completes the Part II-Performance Check and Adjustment procedure.

## **SECTION 6 INSTRUMENT OPTIONS**

No options were available for the 7T11A at the time of this printing.

Information about any subsequent options will be included in the CHANGE INFORMATION section at the rear of this manual.

# REPLACEABLE ELECTRICAL PARTS

## PARTS ORDERING INFORMATION

Replacement parts are available from or through your local Tektronix, Inc. Field Office or representative.

Changes to Tektronix instruments are sometimes made to accommodate improved components as they become available, and to give you the benefit of the latest circuit improvements developed in our engineering department. It is therefore important, when ordering parts, to include the following information in your order: Part number, instrument type or number, serial number, and modification number if applicable.

If a part you have ordered has been replaced with a new or improved part, your local Tektronix, Inc. Field Office or representative will contact you concerning any change in part number.

Change information, if any, is located at the rear of this manual.

### LIST OF ASSEMBLIES

A list of assemblies can be found at the beginning of the Electrical Parts List. The assemblies are listed in numerical order. When the complete component number of a part is known, this list will identify the assembly in which the part is located.

### CROSS INDEX-MFR. CODE NUMBER TO MANUFACTURER

The Mfr. Code Number to Manufacturer index for the Electrical Parts List is located immediately after this page. The Cross Index provides codes, names and addresses of manufacturers of components listed in the Electrical Parts List.

### ABBREVIATIONS

Abbreviations conform to American National Standard Y1.1.

### COMPONENT NUMBER (column one of the Electrical Parts List)

A numbering method has been used to identify assemblies, subassemblies and parts. Examples of this numbering method and typical expansions are illustrated by the following:

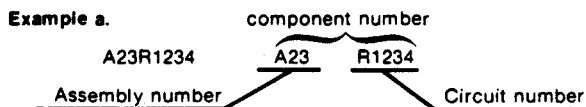

Read: Resistor 1234 of Assembly 23

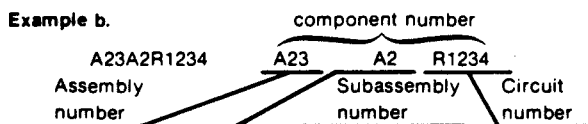

Read: Resistor 1234 of Subassembly 2 of Assembly 23

Only the circuit number will appear on the diagrams and circuit board illustrations. Each diagram and circuit board illustration is clearly marked with the assembly number. Assembly numbers are also marked on the mechanical exploded views located in the Mechanical Parts List. The component number is obtained by adding the assembly number prefix to the circuit number.

The Electrical Parts List is divided and arranged by assemblies in numerical sequence (e.g., assembly A1 with its subassemblies and parts, precedes assembly A2 with its subassemblies and parts).

Chassis-mounted parts have no assembly number prefix and are located at the end of the Electrical Parts List.

### TEKTRONIX PART NO. (column two of the Electrical Parts List)

Indicates part number to be used when ordering replacement part from Tektronix.

### SERIAL/MODEL NO. (columns three and four of the Electrical Parts List)

Column three (3) indicates the serial number at which the part was first used. Column four (4) indicates the serial number at which the part was removed. No serial number entered indicates part is good for all serial numbers.

### NAME & DESCRIPTION (column five of the Electrical Parts List)

In the Parts List, an Item Name is separated from the description by a colon (:). Because of space limitations, an Item Name may sometimes appear as incomplete. For further Item Name identification, the U.S. Federal Cataloging Handbook H6-1 can be utilized where possible.

### MFR. CODE (column six of the Electrical Parts List)

Indicates the code number of the actual manufacturer of the part. (Code to name and address cross reference can be found immediately after this page.)

### MFR. PART NUMBER (column seven of the Electrical Parts List)

Indicates actual manufacturers part number.



CROSS INDEX - MFR. CODE NUMBER TO MANUFACTURER

Mfr. Code	Manufacturer	Address	City, State, Zip Code
00853	SANGAMO WESTON INC SANGAMO CAPACITOR DIV	SANGAMO RD P O BOX 128	PICKENS SC 29671
01121	ALLEN-BRADLEY CO	1201 SOUTH 2ND ST	MILWAUKEE WI 53204
03508	GENERAL ELECTRIC CO SEMI-CONDUCTOR PRODUCTS DEPT	N GENESEE ST	AUBURN NY 13021
03911	CLAIREX ELECTRONICS DIV OF CLAIREX CORP	560 S THIRD AVE	MT VERNON NY 10050
04222	AVX CERAMICS DIV OF AVX CORP	19TH AVE SOUTH P O BOX 867	MYRTLE BEACH SC 29577
04713	MOTOROLA INC SEMICONDUCTOR GROUP	5005 E McDONELL RD	PHOENIX AZ 85008
05397	UNION CARBIDE CORP MATERIALS SYSTEMS DIV	11901 MADISON AVE	CLEVELAND OH 44101
07088	KELVIN ELECTRIC CO	5907 NOBLE AVE	VAN NUYS CA 91411
07263	FAIRCHILD CAMERA AND INSTRUMENT CORP SEMICONDUCTOR DIV	464 ELLIS ST	MOUNTAIN VIEW CA 94042
07716	TRM INC TRM ELECTRONICS COMPONENTS TRM IRC FIXED RESISTORS/BURLINGTON	2850 MT PLEASANT AVE	BURLINGTON IA 52601
12617	HAMLIN INC	GROVE AND LAKE STS	LAKE MILLS WI 53551
12697	CLAROSTAT MFG CO INC	LOWER WASHINGTON ST	DOVER NH 03820
14193	CAL-R INC	1601 OLYMPIC BLVD	SANTA MONICA CA 90404
14433	ITT SEMICONDUCTORS DIV		WEST PALM BEACH FL
14552	MICRO/SEMICONDUCTOR CORP	2830 S FAIRVIEW ST	SANTA ANA CA 92704
15238	ITT SEMICONDUCTORS A DIVISION OF INTERNATIONAL TELEPHONE AND TELEGRAPH CORP	500 BROADWAY P O BOX 168	LAWRENCE MA 01841
15636	ELEC-TROL INC	26477 N GOLDEN VALLEY RD	SAUGUS CA 91350
18324	SIGNETICS CORP	811 E ARQUES	SUNNYVALE CA 94086
19396	ILLINOIS TOOL WORKS INC PAKTRON DIVISION	900 FOLLIN LANE S E	VIENNA VA 22180
19701	MEPCO/ELECTRA INC A NORTH AMERICAN PHILIPS CO	P O BOX 760	MINERAL WELLS TX 76067
20932	KYOCERA INC	11620 SORRENTO VALLEY RD	SAN DIEGO CA 92121
22229	SOLITRON DEVICES INC SEMICONDUCTOR GROUP SAN DIEGO OPERS	8808 BALBOA AVE	SAN DIEGO CA 92123
24546	CORNING GLASS WORKS	550 HIGH ST	BRADFORD PA 16701
24931	SPECIALTY CONNECTOR CO INC	2620 ENDRESS PLACE P O BOX 0	GREENWOOD IN 46142
25403	AMPEREX ELECTRONIC CORP SEMICONDUCTOR AND MICROCIRCUITS DIV	PROVIDENCE PIKE	SLATERSVILLE RI 02876
26805	OMNI SPECTRA INC MICROWAVE CONNECTOR DIV	140 FOURTH AVE	MALTHAM MA 02154
32997	BOURNS INC TRIMPOT DIV	1200 COLUMBIA AVE	RIVERSIDE CA 92507
50434	HENLETT-PACKARD CO OPTOELECTRONICS DIV	640 PAGE MILL RD	PALO ALTO CA 94304
51642	CENTRE ENGINEERING INC	2820 E COLLEGE AVE	STATE COLLEGE PA 16801
52763	STETTNER ELECTRONICS INC	6135 AIRWAYS BLVD PO BOX 21947	CHATTANOOGA TN 37421
53399	GERMANIUM POMER DEVICES CORP	SHAMSHEEN VILLAGE STATION P O BOX 65	ANDOVER MA 01810
54583	TKK ELECTRONICS CORP	755 EASTGATE BLVD	GARDEN CITY NY 11530
56289	SPRAGUE ELECTRIC CO	87 MARSHALL ST	NORTH ADAMS MA 01247
57668	ROHM CORP	16931 MILLIKEN AVE	IRVINE CA 92713
58854	GTE PRODUCTS CORP LIGHTING PRODUCTS GROUP	60 BOSTON ST	SALEM MA 01970
59660	TUSONIX INC	2155 N FORBES BLVD	TUCSON, ARIZONA 85705
59821	CENTRALAB INC SUB NORTH AMERICAN PHILIPS CORP	7158 MERCHANT AVE	EL PASO TX 79915
71590	GLOBE-UNION INC CENTRALAB ELECTRONICS DIV	HMY 20 N P O BOX 858	FORT DODGE IA 50501
72982	ERIE TECHNOLOGICAL PRODUCTS INC	645 N 11TH ST	ERIE PA 16512
73138	BECKMAN INSTRUMENTS INC HELIPOT DIV	2500 HARBOR BLVD	FULLERTON CA 92634
75042	TRM INC TRM ELECTRONIC COMPONENTS IRC FIXED RESISTORS PHILADELPHIA DIV	401 N BROAD ST	PHILADELPHIA PA 19108

## CROSS INDEX - MFR. CODE NUMBER TO MANUFACTURER

Mfr. Code	Manufacturer	Address	City, State, Zip Code
76493	BELL INDUSTRIES INC MILLER J M DIV	19070 REYES AVE P O BOX 5825	COMPTON CA 90224
80009	TEKTRONIX INC	4900 S W GRIFFITH DR P O BOX 500	BEAVERTON OR 97077
91418	RADIO MATERIALS CORP	4242 BYRN MAMR AVE W	CHICAGO IL 60646
95275	VITRAMON INC	BOX 544	BRIDGEPORT CT 06601
98291	SEAELECTRO CORP	225 HOYT	MAMARONECK NY 10544
TK0961	NEC ELECTRONICS USA INC	401 ELLIS ST	MOUNTAIN VIEW CA 94043
TK1345	ZMAN AND ASSOCIATES	7633 S 180TH	KENT MA 98032

Replaceable Electrical Parts - 7T11A

Component No.	Tektronix Part No.	Serial/Assembly No. Effective Dscont	Name & Description	Mfr. Code	Mfr. Part No.
A1	670-1118-09		CIRCUIT BD ASSY:LOGIC	80009	670-1118-09
A2	670-1119-14		CIRCUIT BD ASSY:TIMING	80009	670-1119-14
A3	670-1120-05		CIRCUIT BD ASSY:TRIGGER	80009	670-1120-05
A4	670-1121-04		CIRCUIT BD ASSY:INTERFACE	80009	670-1121-04
A5	670-1195-01		CIRCUIT BD ASSY:TRIGGER AMPLIFIER SM	80009	670-1195-01
A6	670-1196-01		CIRCUIT BD ASSY:TRIGGER SOURCE SM	80009	670-1196-01
A7	670-1197-01		CIRCUIT BD ASSY:SCAN SM	80009	670-1197-01
A8	670-1198-01		CIRCUIT BD ASSY:SLOPE SM	80009	670-1198-01
A9	670-1199-01		CIRCUIT BD ASSY:RANDOM SEQUENCE SM	80009	670-1199-01
A10	670-1184-00		CIRCUIT BD ASSY:COMMUTATOR SM FIXED	80009	670-1184-00
A1	670-1118-09		CIRCUIT BD ASSY:LOGIC	80009	670-1118-09
A1C2	281-0759-00		CAP,FXD,CER DI:22PF,10%,100V	04222	WA101A220KAA
A1C6	281-0759-00		CAP,FXD,CER DI:22PF,10%,100V	04222	WA101A220KAA
A1C592	281-0812-00		CAP,FXD,CER DI:1000PF,10%,100V	04222	WA101C102KAA
A1C594	281-0773-00		CAP,FXD,CER DI:0.01UF,10%,100V	04222	WA201C103KAA
A1C619	281-0812-00		CAP,FXD,CER DI:1000PF,10%,100V	04222	WA101C102KAA
A1C620	281-0826-00		CAP,FXD,CER DI:2200PF,5%,100V	20932	401EM100A0222K
A1C624	281-0762-00		CAP,FXD,CER DI:27PF,20%,100V	04222	WA101A270MAA
A1C625	283-0177-00		CAP,FXD,CER DI:1UF,+80-20%,25V	04222	SR302E105ZAATR
A1C628	281-0759-00		CAP,FXD,CER DI:22PF,10%,100V	04222	WA101A220KAA
A1C630	281-0809-00		CAP,FXD,CER DI:200 PF,5%,100V	04222	WA101A201JAA
A1C631	283-0198-00		CAP,FXD,CER DI:0.22UF,20%,50V	05397	C330C224MSU1CA
A1C636	281-0797-00		CAP,FXD,CER DI:15PF,10%,100V	04222	WA106A150KAA
A1C654	283-0164-00		CAP,FXD,CER DI:2.2UF,20%,25V	04222	SR402E225MAA
A1C674	281-0763-00		CAP,FXD,CER DI:47PF,10%,100V	04222	WA101A470KAA
A1C675	281-0812-00		CAP,FXD,CER DI:1000PF,10%,100V	04222	WA101C102KAA
A1C676	281-0812-00		CAP,FXD,CER DI:1000PF,10%,100V	04222	WA101C102KAA
A1CR4	152-0141-02		SEMICONO DVC,DI:SM,SI,30V,150MA,30V	03508	0A2527 (1N4152)
A1CR5	152-0322-00		SEMICONO DVC,DI:SCHOTTKY BARRIER,SI,15V	50434	5082-2672
A1CR591	152-0141-02		SEMICONO DVC,DI:SM,SI,30V,150MA,30V	03508	0A2527 (1N4152)
A1CR595	152-0141-02		SEMICONO DVC,DI:SM,SI,30V,150MA,30V	03508	0A2527 (1N4152)
A1CR596	152-0141-02		SEMICONO DVC,DI:SM,SI,30V,150MA,30V	03508	0A2527 (1N4152)
A1CR621	152-0141-02		SEMICONO DVC,DI:SM,SI,30V,150MA,30V	03508	0A2527 (1N4152)
A1CR622	152-0141-02		SEMICONO DVC,DI:SM,SI,30V,150MA,30V	03508	0A2527 (1N4152)
A1CR627	152-0141-02		SEMICONO DVC,DI:SM,SI,30V,150MA,30V	03508	0A2527 (1N4152)
A1CR631	152-0141-02		SEMICONO DVC,DI:SM,SI,30V,150MA,30V	03508	0A2527 (1N4152)
A1CR636	152-0141-02		SEMICONO DVC,DI:SM,SI,30V,150MA,30V	03508	0A2527 (1N4152)
A1CR650	152-0141-02		SEMICONO DVC,DI:SM,SI,30V,150MA,30V	03508	0A2527 (1N4152)
A1CR656	152-0141-02		SEMICONO DVC,DI:SM,SI,30V,150MA,30V	03508	0A2527 (1N4152)
A1CR667	152-0141-02		SEMICONO DVC,DI:SM,SI,30V,150MA,30V	03508	0A2527 (1N4152)
A1CR671	152-0141-02		SEMICONO DVC,DI:SM,SI,30V,150MA,30V	03508	0A2527 (1N4152)
A1CR672	152-0322-00		SEMICONO DVC,DI:SCHOTTKY BARRIER,SI,15V	50434	5082-2672
A1CR682	152-0322-00		SEMICONO DVC,DI:SCHOTTKY BARRIER,SI,15V	50434	5082-2672
A1CR807	152-0141-02		SEMICONO DVC,DI:SM,SI,30V,150MA,30V	03508	0A2527 (1N4152)
A1Q1	151-0325-00		TRANSISTOR:PMP,SI,TO-92,SEL	80009	151-0325-00
A1Q2	151-0188-00		TRANSISTOR:PMP,SI,TO-92	80009	151-0188-00
A1Q3	151-0190-00		TRANSISTOR:NPN,SI,TO-92	80009	151-0190-00
A1Q4	151-0190-00		TRANSISTOR:NPN,SI,TO-92	80009	151-0190-00
A1Q5	151-0190-00		TRANSISTOR:NPN,SI,TO-92	80009	151-0190-00
A1Q6	151-0188-00		TRANSISTOR:PMP,SI,TO-92	80009	151-0188-00
A1Q8	151-0219-00		TRANSISTOR:PMP,SI,R-124	07263	S022650
A1Q370	151-0220-00		TRANSISTOR:PMP,SI,TO-92	80009	151-0220-00
A1Q506	151-0190-00		TRANSISTOR:NPN,SI,TO-92	80009	151-0190-00
A1Q592	151-0220-00		TRANSISTOR:PMP,SI,TO-92	80009	151-0220-00
A1Q608	151-0220-00		TRANSISTOR:PMP,SI,TO-92	80009	151-0220-00
A1Q612	151-0219-00		TRANSISTOR:PMP,SI,R-124	07263	S022650
A1Q616	151-1007-00		TRANSISTOR:FET,N-CHAN,SI,TO-71	22229	FD1121
A1Q618	151-0224-00		TRANSISTOR:NPN,SI,TO-92	04713	SPS6917

Component No.	Tektronix Part No.	Serial/Assembly No. Effective Dscont	Name & Description	Mfr. Code	Mfr. Part No.
A1Q620	151-1025-00		TRANSISTOR:FET,N-CHAN,SI,TO-92	04713	SPF3036
A1Q626	151-0224-00		TRANSISTOR:NPN,SI,TO-92	04713	SP56917
A1Q628	151-0220-00		TRANSISTOR:PNP,SI,TO-92	80009	151-0220-00
A1Q634	151-0041-00		TRANSISTOR:PNP,GE,TO-5	53399	2N1303
A1Q636	151-0219-00		TRANSISTOR:PNP,SI,R-124	07263	S022650
A1Q644	151-0164-00		TRANSISTOR:PNP,SI,TO-92	04713	2N2907A
A1Q650	151-0220-00		TRANSISTOR:PNP,SI,TO-92	80009	151-0220-00
A1Q652	151-0190-00		TRANSISTOR:NPN,SI,TO-92	80009	151-0190-00
A1Q654	151-0190-00		TRANSISTOR:NPN,SI,TO-92	80009	151-0190-00
A1Q656	151-1011-00		TRANSISTOR:FE,N CHAN,SI,DUAL,TO-71	04713	SFD1011
A1Q658	151-0224-00		TRANSISTOR:NPN,SI,TO-92	04713	SP56917
A1Q662	151-0219-00		TRANSISTOR:PNP,SI,R-124	07263	S022650
A1Q664	151-0190-00		TRANSISTOR:NPN,SI,TO-92	80009	151-0190-00
A1Q668	151-0219-00		TRANSISTOR:PNP,SI,R-124	07263	S022650
A1Q670	151-0190-00		TRANSISTOR:NPN,SI,TO-92	80009	151-0190-00
A1Q674	151-0410-00		TRANSISTOR:PNP,SI,TO-92	04713	SP56765
A1Q694	151-0188-00		TRANSISTOR:PNP,SI,TO-92	80009	151-0188-00
A1Q714	151-0164-00		TRANSISTOR:PNP,SI,TO-92	04713	2N2907A
A1R1	315-0821-00		RES,FXD,FILM:820 OHM,5%,0.25M	19701	5043CX820R0J
A1R2	315-0203-00		RES,FXD,FILM:20K OHM,5%,0.25M	57668	NTR25J-E 20K
A1R3	315-0472-00		RES,FXD,FILM:4.7K OHM,5%,0.25M	57668	NTR25J-E04K7
A1R4	315-0102-00		RES,FXD,FILM:1K OHM,5%,0.25M	57668	NTR25JE01K0
A1R5	315-0203-00		RES,FXD,FILM:20K OHM,5%,0.25M	57668	NTR25J-E 20K
A1R6	315-0203-00		RES,FXD,FILM:20K OHM,5%,0.25M	57668	NTR25J-E 20K
A1R7	321-0277-00		RES,FXD,FILM:7.50K OHM,1%,0.125M,TC=TO	24546	NA5507501F
A1R8	321-0361-00		RES,FXD,FILM:56.2K OHM,1%,0.125M,TC=TO	07716	CEAD56201F
A1R9	315-0103-00		RES,FXD,FILM:10K OHM,5%,0.25M	19701	5043CX10K00J
A1R20	315-0103-00		RES,FXD,FILM:10K OHM,5%,0.25M	19701	5043CX10K00J
A1R370	315-0472-00		RES,FXD,FILM:4.7K OHM,5%,0.25M	57668	NTR25J-E04K7
A1R504	315-0303-00		RES,FXD,FILM:30K OHM,5%,0.25M	19701	5043CX30K00J
A1R505	315-0563-00		RES,FXD,FILM:56K OHM,5%,0.25M	19701	5043CX56K00J
A1R571	315-0103-00		RES,FXD,FILM:10K OHM,5%,0.25M	19701	5043CX10K00J
A1R572	315-0103-00		RES,FXD,FILM:10K OHM,5%,0.25M	19701	5043CX10K00J
A1R576	315-0105-00		RES,FXD,FILM:1M OHM,5%,0.25M	19701	5043CX1M000J
A1R577	321-0289-00		RES,FXD,FILM:10.0K OHM,1%,0.125M,TC=TO	19701	5033ED10K0F
A1R581	321-0298-00		RES,FXD,FILM:12.4K OHM,1%,0.125M,TC=TO	07716	CEAD12401F
A1R582	321-0356-00		RES,FXD,FILM:49.9K OHM,1%,0.125M,TC=TO	19701	5033ED49K90F
A1R583	321-0310-00		RES,FXD,FILM:16.5K OHM,1%,0.125M,TC=TO	19701	5033ED16K50F
A1R584	321-0327-00		RES,FXD,FILM:24.9K OHM,1%,0.125M,TC=TO	07716	CEAD24901F
A1R585	321-0289-00		RES,FXD,FILM:10.0K OHM,1%,0.125M,TC=TO	19701	5033ED10K0F
A1R586	315-0511-00		RES,FXD,FILM:510 OHM,5%,0.25M	19701	5043CX510R0J
A1R587	315-0223-00		RES,FXD,FILM:22K OHM,5%,0.25M	19701	5043CX22K00J92U
A1R588	311-0607-00		RES,VAR,NONMM:TRMR,10K OHM,0.5M	73138	82-25-2
A1R591	315-0102-00		RES,FXD,FILM:1K OHM,5%,0.25M	57668	NTR25JE01K0
A1R592	315-0513-00		RES,FXD,FILM:51K OHM,5%,0.25M	57668	NTR25J-E51K0
A1R593	301-0822-00		RES,FXD,FILM:8.2K OHM,5%,0.5M	19701	5053CX8K200J
A1R594	321-0260-00		RES,FXD,FILM:4.99K OHM,1%,0.125M,TC=TO	19701	5033ED4K990F
A1R596	315-0623-00		RES,FXD,FILM:62K OHM,5%,0.25M	19701	5043CX62K00J
A1R608	315-0303-00		RES,FXD,FILM:30K OHM,5%,0.25M	19701	5043CX30K00J
A1R611	315-0472-00		RES,FXD,FILM:4.7K OHM,5%,0.25M	57668	NTR25J-E04K7
A1R612	321-0400-00		RES,FXD,FILM:143K OHM,1%,0.125M,TC=TO	19701	5043ED143K0F
A1R613	315-0304-00		RES,FXD,FILM:300K OHM,5%,0.25M	57668	NTR25J-E300K
A1R614	321-0402-00		RES,FXD,FILM:150K OHM,1%,0.125M,TC=TO	19701	5033ED150K0F
A1R615	315-0106-00		RES,FXD,FILM:10M OHM,5%,0.25M	01121	CB1065
A1R616	321-0342-00		RES,FXD,FILM:35.7K OHM,1%,0.125M,TC=TO	07716	CEAD35701F
A1R618	321-0275-00		RES,FXD,FILM:7.15K OHM,1%,0.125M,TC=TO	07716	CEAD71500F
A1R619	315-0106-00		RES,FXD,FILM:10M OHM,5%,0.25M	01121	CB1065
A1R621	315-0513-00		RES,FXD,FILM:51K OHM,5%,0.25M	57668	NTR25J-E51K0
A1R622	315-0752-00		RES,FXD,FILM:7.5K OHM,5%,0.25M	57668	NTR25J-E07K5

Replaceable Electrical Parts - 7T11A

Component No.	Tektronix Part No.	Serial/Assembly No. Effective Dscont	Name & Description	Mfr. Code	Mfr. Part No.
A1R623	315-0104-00		RES, FXD, FILM:100K OHM, 5%, 0.25M	57668	NTR25J-E100K
A1R624	315-0153-00		RES, FXD, FILM:15K OHM, 5%, 0.25M	19701	5043CX15K00J
A1R625	315-0101-00		RES, FXD, FILM:100 OHM, 5%, 0.25M	57668	NTR25J-E 100E
A1R626	315-0512-00		RES, FXD, FILM:5.1K OHM, 5%, 0.25M	57668	NTR25J-E05K1
A1R628	315-0103-00		RES, FXD, FILM:10K OHM, 5%, 0.25M	19701	5043CX10K00J
A1R629	315-0102-00		RES, FXD, FILM:1K OHM, 5%, 0.25M	57668	NTR25JE01K0
A1R630	315-0101-00		RES, FXD, FILM:100 OHM, 5%, 0.25M	57668	NTR25J-E 100E
A1R631	315-0512-00		RES, FXD, FILM:5.1K OHM, 5%, 0.25M	57668	NTR25J-E05K1
A1R632	321-0259-00		RES, FXD, FILM:4.87K OHM, 1%, 0.125M, TC=TO	07716	CEA048700F
A1R633	321-0289-00		RES, FXD, FILM:10.0K OHM, 1%, 0.125M, TC=TO	19701	5033ED10K0F
A1R634	315-0302-00		RES, FXD, FILM:3K OHM, 5%, 0.25M	57668	NTR25J-E03K0
A1R636	315-0103-00		RES, FXD, FILM:10K OHM, 5%, 0.25M	19701	5043CX10K00J
A1R642	315-0273-00		RES, FXD, FILM:27K OHM, 5%, 0.25M	57668	NTR25J-E27K0
A1R643	315-0303-00		RES, FXD, FILM:30K OHM, 5%, 0.25M	19701	5043CX30K00J
A1R644	321-0289-00		RES, FXD, FILM:10.0K OHM, 1%, 0.125M, TC=TO	19701	5033ED10K0F
A1R645	311-0607-00		RES, VAR, NONWH: TRMR, 10K OHM, 0.5M	73138	82-25-2
A1R646	315-0243-00		RES, FXD, FILM:24K OHM, 5%, 0.25M	57668	NTR25J-E24K0
A1R647	321-0289-00		RES, FXD, FILM:10.0K OHM, 1%, 0.125M, TC=TO	19701	5033ED10K0F
A1R650	315-0202-00		RES, FXD, FILM:2K OHM, 5%, 0.25M	57668	NTR25J-E 2K
A1R651	315-0103-00		RES, FXD, FILM:10K OHM, 5%, 0.25M	19701	5043CX10K00J
A1R658	321-0289-00		RES, FXD, FILM:10.0K OHM, 1%, 0.125M, TC=TO	19701	5033ED10K0F
A1R662	315-0363-00		RES, FXD, FILM:36K OHM, 5%, 0.25M	57668	NTR25J-E36K0
A1R663	315-0103-00		RES, FXD, FILM:10K OHM, 5%, 0.25M	19701	5043CX10K00J
A1R664	315-0153-00		RES, FXD, FILM:15K OHM, 5%, 0.25M	19701	5043CX15K00J
A1R665	315-0303-00		RES, FXD, FILM:30K OHM, 5%, 0.25M	19701	5043CX30K00J
A1R666	315-0103-00		RES, FXD, FILM:10K OHM, 5%, 0.25M	19701	5043CX10K00J
A1R667	321-0361-00		RES, FXD, FILM:56.2K OHM, 1%, 0.125M, TC=TO	07716	CEA056201F
A1R668	321-0277-00		RES, FXD, FILM:7.50K OHM, 1%, 0.125M, TC=TO	24546	NA5507501F
A1R669	315-0472-00		RES, FXD, FILM:4.7K OHM, 5%, 0.25M	57668	NTR25J-E04K7
A1R670	315-0103-00		RES, FXD, FILM:10K OHM, 5%, 0.25M	19701	5043CX10K00J
A1R671	315-0102-00		RES, FXD, FILM:1K OHM, 5%, 0.25M	57668	NTR25JE01K0
A1R672	315-0513-00		RES, FXD, FILM:51K OHM, 5%, 0.25M	57668	NTR25J-E51K0
A1R673	321-0289-03		RES, FXD, FILM:10.0K OHM, 0.25%, 0.125M, TC=T2	07716	CEAC10001C
A1R674	321-0289-03		RES, FXD, FILM:10.0K OHM, 0.25%, 0.125M, TC=T2	07716	CEAC10001C
A1R675	315-0101-00		RES, FXD, FILM:100 OHM, 5%, 0.25M	57668	NTR25J-E 100E
A1R676	321-0213-00		RES, FXD, FILM:1.62K OHM, 1%, 0.125M, TC=TO	07716	CEA016200F
A1R677	301-0113-00		RES, FXD, FILM:11K OHM, 5%, 0.5M	19701	5053CX11K00J
A1R682	315-0222-00		RES, FXD, FILM:2.2K OHM, 5%, 0.25M	57668	NTR25J-E02K2
A1R683	315-0103-00		RES, FXD, FILM:10K OHM, 5%, 0.25M	19701	5043CX10K00J
A1R684	315-0103-00		RES, FXD, FILM:10K OHM, 5%, 0.25M	19701	5043CX10K00J
A1R686	321-0213-00		RES, FXD, FILM:1.62K OHM, 1%, 0.125M, TC=TO	07716	CEA016200F
A1R687	301-0123-00		RES, FXD, FILM:12K OHM, 5%, 0.5M	19701	5053CX12K00J
A1R691	315-0393-00		RES, FXD, FILM:39K OHM, 5%, 0.25M	57668	NTR25J-E39K0
A1R692	315-0273-00		RES, FXD, FILM:27K OHM, 5%, 0.25M	57668	NTR25J-E27K0
A1R693	315-0303-00		RES, FXD, FILM:30K OHM, 5%, 0.25M	19701	5043CX30K00J
A1R694	315-0303-00		RES, FXD, FILM:30K OHM, 5%, 0.25M	19701	5043CX30K00J
A1R714	315-0102-00		RES, FXD, FILM:1K OHM, 5%, 0.25M	57668	NTR25JE01K0
A1R807	315-0103-00		RES, FXD, FILM:10K OHM, 5%, 0.25M	19701	5043CX10K00J
A1T650	120-0658-00		XFMR, TOROID:	TK1345	120-0658-00
A1U572	155-0035-00		MICROCKT, LINEAR: QUAD OPNL AMPL	80009	155-0035-00
A2	670-1119-14		CIRCUIT BD ASSY: TIMING	80009	670-1119-14
A2C212	283-0599-00		CAP, FXD, MICA DI: 98PF, 5%, 500V	00853	0105F980J0
A2C213	283-0121-00		CAP, FXD, CER DI: 1000PF, 20%, 200V	91418	5P102M2011958
A2C215	283-0140-00		CAP, FXD, CER DI: 4.7PF, +/-0.25PF, 50V	72982	8101E003A479C
A2C219	283-0121-00		CAP, FXD, CER DI: 1000PF, 20%, 200V	91418	5P102M2011958
A2C221	281-0812-00		CAP, FXD, CER DI: 1000PF, 10%, 100V	04222	MA101C102KAA
A2C224	283-0000-00		CAP, FXD, CER DI: 0.001UF, +100-0%, 500V	59660	831-610-Y5U0102P
A2C228	283-0140-00		CAP, FXD, CER DI: 4.7PF, +/-0.25PF, 50V	72982	8101E003A479C

Component No.	Tektronix Part No.	Serial/Assembly No. Effective Dscont	Name & Description	Mfr. Code	Mfr. Part No.
A2C230	281-0773-00		CAP, FXD, CER DI:0.01UF, 10%, 100V	04222	MA201C103KAA
A2C232	281-0811-00		CAP, FXD, CER DI:10PF, 10%, 100V	04222	MA101A100KAA
A2C234	281-0811-00		CAP, FXD, CER DI:10PF, 10%, 100V	04222	MA101A100KAA
A2C237	281-0122-00		CAP, VAR, CER DI:2.5-9PF, 100V	59660	518-000A2.5-9
A2C251	283-0140-00		CAP, FXD, CER DI:4.7PF, +/-0.25PF, 50V	72982	8101E003A479C
A2C253	283-0140-00		CAP, FXD, CER DI:4.7PF, +/-0.25PF, 50V	72982	8101E003A479C
A2C261	283-0121-00		CAP, FXD, CER DI:1000PF, 20%, 200V	91418	5P102M2011958
A2C263	283-0121-00		CAP, FXD, CER DI:1000PF, 20%, 200V	91418	5P102M2011958
A2C264	283-0135-00		CAP, FXD, CER DI:100PF, 5%, 500V	91418	JK101J501959
A2C271	283-0121-00		CAP, FXD, CER DI:1000PF, 20%, 200V	91418	5P102M2011958
A2C273	283-0121-00		CAP, FXD, CER DI:1000PF, 20%, 200V	91418	5P102M2011958
A2C281	283-0177-00		CAP, FXD, CER DI:1UF, +80-20%, 25V	04222	SR302E105ZAATR
A2C291	281-0562-00		CAP, FXD, CER DI:39PF, 10%, 500V	52763	2RDPLZ007 39POKU
A2C292	281-0123-00		CAP, VAR, CER DI:5-25PF, 100V	59660	518-000A5-25
A2C294	281-0616-00		CAP, FXD, CER DI:6.8PF, +/-0.5PF, 200V	52763	2RDPLZ007 6P800C
A2C298	290-0340-00		CAP, FXD, ELCTLT:10UF, 10%, 50V	56289	1090106X9050C2
A2C299	283-0177-00		CAP, FXD, CER DI:1UF, +80-20%, 25V	04222	SR302E105ZAATR
A2C301	281-0811-00		CAP, FXD, CER DI:10PF, 10%, 100V	04222	MA101A100KAA
A2C308	281-0812-00		CAP, FXD, CER DI:1000PF, 10%, 100V	04222	MA101C102KAA
A2C312	281-0811-00		CAP, FXD, CER DI:10PF, 10%, 100V	04222	MA101A100KAA
A2C313	281-0123-00		CAP, VAR, CER DI:5-25PF, 100V	59660	518-000A5-25
A2C316	283-0000-00		CAP, FXD, CER DI:0.001UF, +100-0%, 500V	59660	831-610-Y5U0102P
A2C320	281-0811-00		CAP, FXD, CER DI:10PF, 10%, 100V	04222	MA101A100KAA
A2C322	283-0177-00		CAP, FXD, CER DI:1UF, +80-20%, 25V	04222	SR302E105ZAATR
A2C324	281-0759-00		CAP, FXD, CER DI:22PF, 10%, 100V	04222	MA101A220KAA
A2C328	283-0154-00		CAP, FXD, CER DI:22PF, 5%, 50V	04222	SR155A220JAA
A2C342	283-0070-00		CAP, FXD, CER DI:30PF, 10%, 50V	51642	200-050-NPO-300K
A2C344	283-0070-00		CAP, FXD, CER DI:30PF, 10%, 50V	51642	200-050-NPO-300K
A2C346	283-0121-00		CAP, FXD, CER DI:1000PF, 20%, 200V	91418	5P102M2011958
A2C348	281-0762-00		CAP, FXD, CER DI:27PF, 20%, 100V	04222	MA101A270MAA
A2C349	281-0773-00		CAP, FXD, CER DI:0.01UF, 10%, 100V	04222	MA201C103KAA
A2C353	283-0253-00		CAP, FXD, CER DI:0.01UF, 10%, 100V	04222	15051C103KZT6C
A2C356	281-0811-00		CAP, FXD, CER DI:10PF, 10%, 100V	04222	MA101A100KAA
A2C358	281-0812-00		CAP, FXD, CER DI:1000PF, 10%, 100V	04222	MA101C102KAA
A2C359	281-0812-00		CAP, FXD, CER DI:1000PF, 10%, 100V	04222	MA101C102KAA
A2C369	283-0121-00		CAP, FXD, CER DI:1000PF, 20%, 200V	91418	5P102M2011958
A2C401	283-0150-00		CAP, FXD, CER DI:650PF, 5%, 200V	59821	20DH60K651J
A2C402	283-0599-00		CAP, FXD, MICA DI:98PF, 5%, 500V	00853	D105F980J0
A2C403	283-0599-00		CAP, FXD, MICA DI:98PF, 5%, 500V	00853	D105F980J0
A2C411	290-0269-00		CAP, FXD, ELCTLT:0.22UF, 5%, 35V	05397	T320A224J035AS
A2C412	290-0282-00		CAP, FXD, ELCTLT:0.047UF, 10%, 35V	05397	T320A473K035AS
A2C414	281-0774-00		CAP, FXD, CER DI:0.022MFD, 20%, 100V	04222	MA201E223MAA
A2C416	281-0775-00		CAP, FXD, CER DI:0.1UF, 20%, 50V	04222	MA205E104MAA
A2C421	281-0774-00		CAP, FXD, CER DI:0.022MFD, 20%, 100V	04222	MA201E223MAA
A2C424	281-0812-00		CAP, FXD, CER DI:1000PF, 10%, 100V	04222	MA101C102KAA
A2C451	281-0812-00		CAP, FXD, CER DI:1000PF, 10%, 100V	04222	MA101C102KAA
A2C455	281-0775-00		CAP, FXD, CER DI:0.1UF, 20%, 50V	04222	MA205E104MAA
A2C456	281-0812-00		CAP, FXD, CER DI:1000PF, 10%, 100V	04222	MA101C102KAA
A2C463	283-0121-00		CAP, FXD, CER DI:1000PF, 20%, 200V	91418	5P102M2011958
A2C509	281-0773-00		CAP, FXD, CER DI:0.01UF, 10%, 100V	04222	MA201C103KAA
A2C512	281-0861-00		CAP, FXD, CER DI:270PF, 5%, 50V	54583	MA12C061H271J
A2C518	281-0861-00		CAP, FXD, CER DI:270PF, 5%, 50V	54583	MA12C061H271J
A2C551	283-0642-00		CAP, FXD, MICA DI:33PF, +/-0.5PF, 300V	00853	D105E330G0
A2C555	281-0861-00		CAP, FXD, CER DI:270PF, 5%, 50V	54583	MA12C061H271J
A2C566	281-0798-00		CAP, FXD, CER DI:51PF, 1%, 100V	04222	MA101A510GAA
A2C573	281-0775-00		CAP, FXD, CER DI:0.1UF, 20%, 50V	04222	MA205E104MAA
A2C603	283-0177-00		CAP, FXD, CER DI:1UF, +80-20%, 25V	04222	SR302E105ZAATR
A2C604	281-0812-00		CAP, FXD, CER DI:1000PF, 10%, 100V	04222	MA101C102KAA
A2C821	283-0253-00		CAP, FXD, CER DI:0.01UF, 10%, 100V	04222	15051C103KZT6C

Replaceable Electrical Parts - 7T11A

Component No.	Tektronix Part No.	Serial/Assembly No. Effective Dscont	Name & Description	Mfr. Code	Mfr. Part No.
A2C823	283-0121-00		CAP,FXD,CER DI:1000PF,20%,200V	91418	5P102M2011958
A2C824	283-0253-00		CAP,FXD,CER DI:0.01UF,10%,100V	04222	15051C103KZT6C
A2C826	283-0253-00		CAP,FXD,CER DI:0.01UF,10%,100V	04222	15051C103KZT6C
A2C827	283-0253-00		CAP,FXD,CER DI:0.01UF,10%,100V	04222	15051C103KZT6C
A2CR212	152-0141-02		SEMICOND DVC,DI:SM,SI,30V,150MA,30V	03508	0A2527 (1N4152)
A2CR234	152-0141-02		SEMICOND DVC,DI:SM,SI,30V,150MA,30V	03508	0A2527 (1N4152)
A2CR244	152-0141-02		SEMICOND DVC,DI:SM,SI,30V,150MA,30V	03508	0A2527 (1N4152)
A2CR251	152-0141-02		SEMICOND DVC,DI:SM,SI,30V,150MA,30V	03508	0A2527 (1N4152)
A2CR284	152-0141-02		SEMICOND DVC,DI:SM,SI,30V,150MA,30V	03508	0A2527 (1N4152)
A2CR294	152-0141-02		SEMICOND DVC,DI:SM,SI,30V,150MA,30V	03508	0A2527 (1N4152)
A2CR295	152-0141-02		SEMICOND DVC,DI:SM,SI,30V,150MA,30V	03508	0A2527 (1N4152)
A2CR296	152-0141-02		SEMICOND DVC,DI:SM,SI,30V,150MA,30V	03508	0A2527 (1N4152)
A2CR303	152-0322-00		SEMICOND DVC,DI:SCOTTKY BARRIER,SI,15V	50434	5082-2672
A2CR304	152-0322-00		SEMICOND DVC,DI:SCOTTKY BARRIER,SI,15V	50434	5082-2672
A2CR305	152-0322-00		SEMICOND DVC,DI:SCOTTKY BARRIER,SI,15V	50434	5082-2672
A2CR316	152-0322-00		SEMICOND DVC,DI:SCOTTKY BARRIER,SI,15V	50434	5082-2672
A2CR348	152-0141-02		SEMICOND DVC,DI:SM,SI,30V,150MA,30V	03508	0A2527 (1N4152)
A2CR357	152-0141-02		SEMICOND DVC,DI:SM,SI,30V,150MA,30V	03508	0A2527 (1N4152)
A2CR358	152-0141-02		SEMICOND DVC,DI:SM,SI,30V,150MA,311V	03508	0A2527 (1N4152)
A2CR364	152-0141-02		SEMICOND DVC,DI:SM,SI,30V,150MA,30V	03508	0A2527 (1N4152)
A2CR400	152-0141-02		SEMICOND DVC,DI:SM,SI,30V,150MA,30V	03508	0A2527 (1N4152)
A2CR405	152-0141-02		SEMICOND DVC,DI:SM,SI,30V,150MA,30V	03508	0A2527 (1N4152)
A2CR406	152-0141-02		SEMICOND DVC,DI:SM,SI,30V,150MA,311V	03508	0A2527 (1N4152)
A2CR411	152-0333-00		SEMICOND DVC,DI:SM,SI,55V,200MA,00-35	07263	FDH-6012
A2CR412	152-0333-00		SEMICOND DVC,DI:SM,SI,55V,200MA,00-35	07263	FDH-6012
A2CR414	152-0141-02		SEMICOND DVC,DI:SM,SI,30V,150MA,30V	03508	0A2527 (1N4152)
A2CR416	152-0141-02		SEMICOND DVC,DI:SM,SI,30V,150MA,30V	03508	0A2527 (1N4152)
A2CR446	152-0141-02		SEMICOND DVC,DI:SM,SI,30V,150MA,30V	03508	0A2527 (1N4152)
A2CR502	152-0141-02		SEMICOND DVC,DI:SM,SI,30V,150MA,30V	03508	0A2527 (1N4152)
A2CR503	152-0141-02		SEMICOND DVC,DI:SM,SI,30V,150MA,30V	03508	0A2527 (1N4152)
A2CR514	152-0071-00		SEMICOND DVC,DI:SM,GE,15V,40MA,00-7	15238	G865
A2CR515	152-0141-02		SEMICOND DVC,DI:SM,SI,30V,150MA,30V	03508	0A2527 (1N4152)
A2CR525	152-0141-02		SEMICOND DVC,DI:SM,SI,30V,150MA,30V	03508	0A2527 (1N4152)
A2CR527	152-0071-00		SEMICOND DVC,DI:SM,GE,15V,40MA,00-7	15238	G865
A2CR547	152-0322-00		SEMICOND DVC,DI:SCOTTKY BARRIER,SI,15V	50434	5082-2672
A2CR562	152-0141-02		SEMICOND DVC,DI:SM,SI,30V,150MA,30V	03508	0A2527 (1N4152)
A2J342	131-0265-00		CONN,RCPT,ELEC:MINTR,CKT 80 MTD,MALE	98291	051-053-0000
A2J344	131-0265-00		CONN,RCPT,ELEC:MINTR,CKT 80 MTD,MALE	98291	051-053-0000
A2Q212	151-0271-00		TRANSISTOR:PMP,SI,TO-92	04713	SPS8236
A2Q214	151-0269-00		TRANSISTOR:NPN,SI,TO-92	TK0961	4163280
A2Q216	151-0282-00		TRANSISTOR:NPN,SI,TO-72	04713	SRF2625
A2Q218	151-0282-00		TRANSISTOR:NPN,SI,TO-72	04713	SRF2625
A2Q222	151-0220-00		TRANSISTOR:PMP,SI,TO-92	80009	151-0220-00
A2Q228	151-0202-00		TRANSISTOR:PMP,SI,TO-72	04713	SS2025
A2Q230	151-0188-00		TRANSISTOR:PMP,SI,TO-92	80009	151-0188-00
A2Q234	151-0190-00		TRANSISTOR:NPN,SI,TO-92	80009	151-0190-00
A2Q242	151-0224-00		TRANSISTOR:NPN,SI,TO-92	04713	SPS6917
A2Q244	151-0190-00		TRANSISTOR:NPN,SI,TO-92	80009	151-0190-00
A2Q252	151-0282-00		TRANSISTOR:NPN,SI,TO-72	04713	SRF2625
A2Q262	151-0202-00		TRANSISTOR:PMP,SI,TO-72	04713	SS2025
A2Q272	151-0282-00		TRANSISTOR:NPN,SI,TO-72	04713	SRF2625
A2Q280	151-1011-00		TRANSISTOR:FE,N-CHAN,SI,DUAL,TO-71	04713	SFD1011
A2Q282	151-0224-00		TRANSISTOR:NPN,SI,TO-92	04713	SPS6917
A2Q284	151-0219-00		TRANSISTOR:PMP,SI,R-124	07263	S022650
A2Q286	151-0224-00		TRANSISTOR:NPN,SI,TO-92	04713	SPS6917
A2Q294	151-1021-00		TRANSISTOR:FET,N-CHAN,SI,TO-18	80009	151-1021-00
A2Q304	151-0221-00		TRANSISTOR:PMP,SI,TO-92	80009	151-0221-00
A2Q306	151-0221-00		TRANSISTOR:PMP,SI,TO-92	80009	151-0221-00
A2Q308	151-0224-00		TRANSISTOR:NPN,SI,TO-92	04713	SPS6917

Component No.	Tektronix Part No.	Serial/Assembly No. Effective Dscnt	Name & Description	Mfr. Code	Mfr. Part No.
A2Q316	151-0190-00		TRANSISTOR:NPN,SI,TO-92	80009	151-0190-00
A2Q318	151-0188-00		TRANSISTOR:PNP,SI,TO-92	80009	151-0188-00
A2Q322	151-0269-00		TRANSISTOR:NPN,SI,TO-92	TK0961	4163280
A2Q326	151-0164-00		TRANSISTOR:PNP,SI,TO-92	04713	2N2907A
A2Q328	151-0719-00		TRANSISTOR:PNP,SI,TO-92	04713	SPS8226 (MPSH81)
A2Q329	151-0367-00		TRANSISTOR:NPN,SI,X-55	04713	SPS 8811
A2Q342	151-0142-00		TRANSISTOR:PNP,SI,TO-38	80009	151-0142-00
A2Q344	151-0142-00		TRANSISTOR:PNP,SI,TO-38	80009	151-0142-00
A2Q352	151-0188-00		TRANSISTOR:PNP,SI,TO-92	80009	151-0188-00
A2Q356	151-0225-00		TRANSISTOR:NPN,SI,TO-106	04713	SPS7890
A2Q362	151-0188-00		TRANSISTOR:PNP,SI,TO-92	80009	151-0188-00
A2Q368	151-0190-00		TRANSISTOR:NPN,SI,TO-92	80009	151-0190-00
A2Q400	151-0190-00		TRANSISTOR:NPN,SI,TO-92	80009	151-0190-00
A2Q402	151-0190-00		TRANSISTOR:NPN,SI,TO-92	80009	151-0190-00
A2Q404	151-0188-00		TRANSISTOR:PNP,SI,TO-92	80009	151-0188-00
A2Q406	151-0190-00		TRANSISTOR:NPN,SI,TO-92	80009	151-0190-00
A2Q414	151-0302-00		TRANSISTOR:NPN,SI,TO-18	04713	ST899
A2Q416	151-0302-00		TRANSISTOR:NPN,SI,TO-18	04713	ST899
A2Q422	151-1005-00		TRANSISTOR:FET,N-CHAN,SI,TO-106	04713	SPF685
A2Q424	151-0224-00		TRANSISTOR:NPN,SI,TO-92	04713	SPS6917
A2Q434	151-0192-00		TRANSISTOR:SELECTED	04713	SPS8801
A2Q438	151-0192-00		TRANSISTOR:SELECTED	04713	SPS8801
A2Q446	151-0225-00		TRANSISTOR:NPN,SI,TO-106	04713	SPS7890
A2Q448	151-0225-00		TRANSISTOR:NPN,SI,TO-106	04713	SPS7890
A2Q452	151-1011-00		TRANSISTOR:FE,N CHAN,SI,DUAL,TO-71	04713	SFD1011
A2Q454	151-0220-00		TRANSISTOR:PNP,SI,TO-92	80009	151-0220-00
A2Q462	151-0164-00		TRANSISTOR:PNP,SI,TO-92	04713	2N2907A
A2Q464	151-0224-00		TRANSISTOR:NPN,SI,TO-92	04713	SPS6917
A2Q512	151-0220-00		TRANSISTOR:PNP,SI,TO-92	80009	151-0220-00
A2Q514	153-0588-00		TRANSISTOR:SELECTED	80009	153-0588-00
A2Q524	153-0588-00		TRANSISTOR:SELECTED	80009	153-0588-00
A2Q542	151-0164-00		TRANSISTOR:PNP,SI,TO-92	04713	2N2907A
A2Q544	151-0207-00		TRANSISTOR:NPN,SI,X-55,SEL	57668	XD118CP0207
A2Q546	151-0188-00		TRANSISTOR:PNP,SI,TO-92	80009	151-0188-00
A2Q552	151-0190-00		TRANSISTOR:NPN,SI,TO-92	80009	151-0190-00
A2Q554	151-0041-00		TRANSISTOR:PNP,GE,TO-5	53399	2N1303
A2Q555	151-0269-00		TRANSISTOR:NPN,SI,TO-92	TK0961	4163280
A2Q556	151-1021-00		TRANSISTOR:FET,N-CHAN,SI,TO-18	80009	151-1021-00
A2Q560	151-1007-00		TRANSISTOR:FET,N-CHAN,SI,TO-71	22229	FD1121
A2Q564	151-0219-00		TRANSISTOR:PNP,SI,R-124	07263	S022650
A2Q568	151-0224-00		TRANSISTOR:NPN,SI,TO-92	04713	SPS6917
A2Q724	151-0207-00		TRANSISTOR:NPN,SI,X-55,SEL	57668	XD118CP0207
A2Q734	151-0207-00		TRANSISTOR:NPN,SI,X-55,SEL	57668	XD118CP0207
A2R211	317-0103-00		RES,FXD,CMPSN:10K OHM,5%,0.125M	01121	881035
A2R212	317-0104-00		RES,FXD,CMPSN:100K OHM,5%,0.125M	01121	881045
A2R213	317-0103-00		RES,FXD,CMPSN:10K OHM,5%,0.125M	01121	881035
A2R214	315-0302-00		RES,FXD,FILM:3K OHM,5%,0.25M	57668	NTR25J-E03K0
A2R215	317-0102-00		RES,FXD,CMPSN:1K OHM,5%,0.125M	01121	881025
A2R216	317-0101-00		RES,FXD,CMPSN:100 OHM,5%,0.125M	01121	881015
A2R217	315-0103-00		RES,FXD,FILM:10K OHM,5%,0.25M	19701	5043CX10K00J
A2R218	317-0102-00		RES,FXD,CMPSN:1K OHM,5%,0.125M	01121	881025
A2R219	317-0332-00		RES,FXD,CMPSN:3.3K OHM,5%,0.125M	01121	883325
A2R221	317-0273-00		RES,FXD,CMPSN:27K OHM,5%,0.125M	01121	882735
A2R222	315-0303-00		RES,FXD,FILM:30K OHM,5%,0.25M	19701	5043CX30K00J
A2R223	317-0273-00		RES,FXD,CMPSN:27K OHM,5%,0.125M	01121	882735
A2R224	315-0303-00		RES,FXD,FILM:30K OHM,5%,0.25M	19701	5043CX30K00J
A2R225	317-0303-00		RES,FXD,CMPSN:30K OHM,5%,0.125M	01121	883035
A2R226	315-0392-00		RES,FXD,FILM:3.9K OHM,5%,0.25M	57668	NTR25J-E03K9
A2R227	317-0101-00		RES,FXD,CMPSN:100 OHM,5%,0.125M	01121	881015



Replaceable Electrical Parts - 7T11A

Component No.	Tektronix Part No.	Serial/Assembly No. Effective Dscont	Name & Description	Mfr. Code	Mfr. Part No.
A2R228	317-0200-00		RES,FXD,CMPSN:20 OHM,5%,0.125M	01121	882005
A2R232	315-0563-00		RES,FXD,FILM:56K OHM,5%,0.25M	19701	5043CX56K00J
A2R233	315-0103-00		RES,FXD,FILM:10K OHM,5%,0.25M	19701	5043CX10K00J
A2R234	315-0623-00		RES,FXD,FILM:62K OHM,5%,0.25M	19701	5043CX62K00J
A2R241	315-0303-00		RES,FXD,FILM:30K OHM,5%,0.25M	19701	5043CX30K00J
A2R242	315-0363-00		RES,FXD,FILM:36K OHM,5%,0.25M	57668	NTR25J-E36K0
A2R243	315-0203-00		RES,FXD,FILM:20K OHM,5%,0.25M	57668	NTR25J-E 20K
A2R251	317-0102-00		RES,FXD,CMPSN:1K OHM,5%,0.125M	01121	881025
A2R252	317-0103-00		RES,FXD,CMPSN:10K OHM,5%,0.125M	01121	881035
A2R253	317-0200-00		RES,FXD,CMPSN:20 OHM,5%,0.125M	01121	882005
A2R260	311-0609-00		RES,VAR,NONNM:TRMR,2K OHM,0.5M	32997	3329H-L58-202
A2R261	323-0282-00		RES,FXD,FILM:8.45K OHM,1%,0.5M,TC=T0	80009	323-0282-00
A2R262	317-0302-00		RES,FXD,CMPSN:3K OHM,5%,0.125M	01121	883025
A2R263	317-0202-00		RES,FXD,CMPSN:2K OHM,5%,0.125M	01121	882025
A2R264	317-0101-00		RES,FXD,CMPSN:100 OHM,5%,0.125M	01121	881015
A2R265	311-0660-00		RES,VAR,NONNM:TRMR,200K OHM,0.5M	32997	3329H-L58-204
A2R266	322-0473-00		RES,FXD,FILM:825K OHM,1%,0.25M,TC=T0	19701	5043R0825K0F
A2R270	311-1265-00		RES,VAR,NONNM:TRMR,2K OHM,0.5M	32997	3329P-L58-202
A2R271	323-0282-00		RES,FXD,FILM:8.45K OHM,1%,0.5M,TC=T0	80009	323-0282-00
A2R272	317-0202-00		RES,FXD,CMPSN:2K OHM,5%,0.125M	01121	882025
A2R273	317-0133-00		RES,FXD,CMPSN:13K OHM,5%,0.125M	01121	881335
A2R274	317-0101-00		RES,FXD,CMPSN:100 OHM,5%,0.125M	01121	881015
A2R281	321-0246-00		RES,FXD,FILM:3.57K OHM,1%,0.125M,TC=T0	19701	5043ED3K570F
A2R282	321-0246-00		RES,FXD,FILM:3.57K OHM,1%,0.125M,TC=T0	19701	5043ED3K570F
A2R283	321-0342-00		RES,FXD,FILM:35.7K OHM,1%,0.125M,TC=T0	07716	CEAD35701F
A2R284	315-0511-00		RES,FXD,FILM:510 OHM,5%,0.25M	19701	5043CX510R0J
A2R285	301-0392-00		RES,FXD,FILM:3.9K OHM,5%,0.5M	19701	5053CX3K900J
A2R286	315-0103-00		RES,FXD,FILM:10K OHM,5%,0.25M	19701	5043CX10K00J
A2R287	321-0289-00		RES,FXD,FILM:10.0K OHM,1%,0.125M,TC=T0	19701	5033ED10K0F
A2R294	315-0683-00		RES,FXD,FILM:68K OHM,5%,0.25M	57668	NTR25J-E68K0
A2R296	315-0203-00		RES,FXD,FILM:20K OHM,5%,0.25M	57668	NTR25J-E 20K
A2R299	315-0622-00		RES,FXD,FILM:6.2K OHM,5%,0.25M	19701	5043CX6K200J
A2R301	315-0303-00		RES,FXD,FILM:30K OHM,5%,0.25M	19701	5043CX30K00J
A2R302	315-0103-00		RES,FXD,FILM:10K OHM,5%,0.25M	19701	5043CX10K00J
A2R304	315-0103-00		RES,FXD,FILM:10K OHM,5%,0.25M	19701	5043CX10K00J
A2R308	315-0101-00		RES,FXD,FILM:100 OHM,5%,0.25M	57668	NTR25J-E 100E
A2R309	321-0270-00		RES,FXD,FILM:6.34K OHM,1%,0.125M,TC=T0	19701	5043ED6K340F
A2R310	311-1263-00		RES,VAR,NONNM:1K OHM,10%,0.50M	32997	3329P-L58-102
A2R320	315-0392-00		RES,FXD,FILM:3.9K OHM,5%,0.25M	57668	NTR25J-E03K9
A2R321	315-0103-00		RES,FXD,FILM:10K OHM,5%,0.25M	19701	5043CX10K00J
A2R324	315-0153-00		RES,FXD,FILM:15K OHM,5%,0.25M	19701	5043CX15K00J
A2R325	317-0470-00		RES,FXD,CMPSN:47 OHM,5%,0.125M	01121	884705
A2R326	315-0303-00		RES,FXD,FILM:30K OHM,5%,0.25M	19701	5043CX30K00J
A2R327	315-0303-00		RES,FXD,FILM:30K OHM,5%,0.25M	19701	5043CX30K00J
A2R328	317-0681-00		RES,FXD,CMPSN:680 OHM,5%,0.125M	01121	886815
A2R329	317-0512-00		RES,FXD,CMPSN:5.1K OHM,5%,0.125M	01121	885125
A2R330	317-0123-00		RES,FXD,CMPSN:12K OHM,5%,0.125M	01121	881235
A2R341	317-0913-00		RES,FXD,CMPSN:91K OHM,5%,0.125M	01121	889135
A2R342	317-0102-00		RES,FXD,CMPSN:1K OHM,5%,0.125M	01121	881025
A2R344	317-0102-00		RES,FXD,CMPSN:1K OHM,5%,0.125M	01121	881025
A2R346	317-0100-00		RES,FXD,CMPSN:10 OHM,5%,0.125M	01121	881005
A2R348	315-0303-00		RES,FXD,FILM:30K OHM,5%,0.25M	19701	5043CX30K00J
A2R351	315-0472-00		RES,FXD,FILM:4.7K OHM,5%,0.25M	57668	NTR25J-E04K7
A2R353	315-0100-00		RES,FXD,FILM:10 OHM,5%,0.25M	19701	5043CX10R00J
A2R355	315-0103-00		RES,FXD,FILM:10K OHM,5%,0.25M	19701	5043CX10K00J
A2R356	315-0103-00		RES,FXD,FILM:10K OHM,5%,0.25M	19701	5043CX10K00J
A2R357	315-0102-00		RES,FXD,FILM:1K OHM,5%,0.25M	57668	NTR25J-E01K0
A2R358	315-0822-00		RES,FXD,FILM:8.2K OHM,5%,0.25M	19701	5043CX8K200J
A2R359	315-0471-00		RES,FXD,FILM:470 OHM,5%,0.25M	57668	NTR25J-E470E

Component No.	Tektronix Part No.	Serial/Assembly No. Effective Dscont	Name & Description	Mfr. Code	Mfr. Part No.
A2R361	315-0103-00		RES,FXD,FILM:10K OHM,5%,0.25M	19701	5043CX10K00J
A2R363	315-0102-00		RES,FXD,FILM:1K OHM,5%,0.25M	57668	NTR25JE01K0
A2R364	315-0203-00		RES,FXD,FILM:20K OHM,5%,0.25M	57668	NTR25J-E 20K
A2R365	315-0473-00		RES,FXD,FILM:47K OHM,5%,0.25M	57668	NTR25J-E47K0
A2R366	315-0513-00		RES,FXD,FILM:51K OHM,5%,0.25M	57668	NTR25J-E51K0
A2R368	315-0472-00		RES,FXD,FILM:4.7K OHM,5%,0.25M	57668	NTR25J-E04K7
A2R401	315-0102-00		RES,FXD,FILM:1K OHM,5%,0.25M	57668	NTR25JE01K0
A2R402	315-0472-00		RES,FXD,FILM:4.7K OHM,5%,0.25M	57668	NTR25J-E04K7
A2R403	315-0472-00		RES,FXD,FILM:4.7K OHM,5%,0.25M	57668	NTR25J-E04K7
A2R404	315-0103-00		RES,FXD,FILM:10K OHM,5%,0.25M	19701	5043CX10K00J
A2R405	315-0472-00		RES,FXD,FILM:4.7K OHM,5%,0.25M	57668	NTR25J-E04K7
A2R406	315-0752-00		RES,FXD,FILM:7.5K OHM,5%,0.25M	57668	NTR25J-E07K5
A2R408	315-0183-00		RES,FXD,FILM:18K OHM,5%,0.25M	19701	5043CX18K00J
A2R409	315-0393-00		RES,FXD,FILM:39K OHM,5%,0.25M	57668	NTR25J-E39K0
A2R411	315-0243-00		RES,FXD,FILM:24K OHM,5%,0.25M	57668	NTR25J-E24K0
A2R412	315-0822-00		RES,FXD,FILM:8.2K OHM,5%,0.25M	19701	5043CX8K200J
A2R415	315-0513-00		RES,FXD,FILM:51K OHM,5%,0.25M	57668	NTR25J-E51K0
A2R422	315-0102-00		RES,FXD,FILM:1K OHM,5%,0.25M	57668	NTR25JE01K0
A2R423	315-0103-00		RES,FXD,FILM:10K OHM,5%,0.25M	19701	5043CX10K00J
A2R424	315-0202-00		RES,FXD,FILM:2K OHM,5%,0.25M	57668	NTR25J-E 2K
A2R432	321-0318-00		RES,FXD,FILM:20.0K OHM,1%,0.125M,TC=T0	19701	5033ED20K00F
A2R433	315-0203-00		RES,FXD,FILM:20K OHM,5%,0.25M	57668	NTR25J-E 20K
A2R434	315-0433-00		RES,FXD,FILM:43K OHM,5%,0.25M	19701	5043CX43K00J
A2R435	321-0320-00		RES,FXD,FILM:21.0K OHM,1%,0.125M,TC=T0	19701	5033ED21K00F
A2R436	321-0385-00		RES,FXD,FILM:100K OHM,1%,0.125M,TC=T0	19701	5033ED100K0F
A2R437	315-0393-00		RES,FXD,FILM:39K OHM,5%,0.25M	57668	NTR25J-E39K0
A2R438	315-0512-00		RES,FXD,FILM:5.1K OHM,5%,0.25M	57668	NTR25J-E05K1
A2R439	315-0103-00		RES,FXD,FILM:10K OHM,5%,0.25M	19701	5043CX10K00J
A2R440	311-1271-00		RES,VAR,NONM:TRMR,50K OHM,0.5M	32997	3329P-L58-503
A2R441	321-0381-00		RES,FXD,FILM:90.9K OHM,1%,0.125M,TC=T0	07716	CEAD90901F
A2R442	315-0224-00		RES,FXD,FILM:220K OHM,5%,0.25M	57668	NTR25J-E220K
A2R443	315-0274-00		RES,FXD,FILM:270K OHM,5%,0.25M	57668	NTR25J-E270K
A2R445	315-0103-00		RES,FXD,FILM:10K OHM,5%,0.25M	19701	5043CX10K00J
A2R452	315-0513-00		RES,FXD,FILM:51K OHM,5%,0.25M	57668	NTR25J-E51K0
A2R453	315-0203-00		RES,FXD,FILM:20K OHM,5%,0.25M	57668	NTR25J-E 20K
A2R454	315-0153-00		RES,FXD,FILM:15K OHM,5%,0.25M	19701	5043CX15K00J
A2R456	315-0102-00		RES,FXD,FILM:1K OHM,5%,0.25M	57668	NTR25JE01K0
A2R458	315-0102-00		RES,FXD,FILM:1K OHM,5%,0.25M	57668	NTR25JE01K0
A2R462	315-0333-00		RES,FXD,FILM:33K OHM,5%,0.25M	57668	NTR25J-E33K0
A2R463	317-0100-00		RES,FXD,CMPSN:10 OHM,5%,0.125M	01121	881005
A2R464	315-0243-00		RES,FXD,FILM:24K OHM,5%,0.25M	57668	NTR25J-E24K0
A2R500	311-1269-00		RES,VAR,NONM:TRMR,20K OHM,0.5M	32997	3329P-L58-203
A2R501	315-0104-00		RES,FXD,FILM:100K OHM,5%,0.25M	57668	NTR25J-E100K
A2R502	315-0913-00		RES,FXD,FILM:91K OHM,5%,0.25M	19701	5043CX91K00J
A2R507	321-0331-00		RES,FXD,FILM:27.4K OHM,1%,0.125M,TC=T0	19701	5043ED27K40F
A2R508	315-0475-00		RES,FXD,FILM:4.7M OHM,5%,0.25M	01121	CB4755
A2R509	321-0358-00		RES,FXD,FILM:52.3K OHM,1%,0.125M,TC=T0	07716	CEAD52301F
A2R510	315-0104-00		RES,FXD,FILM:100K OHM,5%,0.25M	57668	NTR25J-E100K
A2R511	315-0335-00		RES,FXD,FILM:3.3M OHM,5%,0.25M	01121	CB3355
A2R512	315-0101-00		RES,FXD,FILM:100 OHM,5%,0.25M	57668	NTR25J-E 100E
A2R513	315-0333-00		RES,FXD,FILM:33K OHM,5%,0.25M	57668	NTR25J-E33K0
A2R514	315-0103-00		RES,FXD,FILM:10K OHM,5%,0.25M	19701	5043CX10K00J
A2R515	321-1381-03		RES,FXD,FILM:92.0K OHM,0.25%,0.125M,TC=T2	19701	5033RC92K00C
A2R516	315-0513-00		RES,FXD,FILM:51K OHM,5%,0.25M	57668	NTR25J-E51K0
A2R517	321-0289-03		RES,FXD,FILM:10.0K OHM,0.25%,0.125M,TC=T2	07716	CEAC10001C
A2R518	315-0101-00		RES,FXD,FILM:100 OHM,5%,0.25M	57668	NTR25J-E 100E
A2R523	315-0103-00		RES,FXD,FILM:10K OHM,5%,0.25M	19701	5043CX10K00J
A2R525	321-0381-03		RES,FXD,FILM:90.9K OHM,0.25%,0.125M,T=T2	07716	CEAC90901C
A2R526	315-0513-00		RES,FXD,FILM:51K OHM,5%,0.25M	57668	NTR25J-E51K0

Replaceable Electrical Parts - 7T11A

Component No.	Tektronix Part No.	Serial/Assembly No. Effective Dscont	Name & Description	Mfr. Code	Mfr. Part No.
A2R527	321-0289-03		RES, FXD, FILM:10.0K OHM, 0.25%, 0.125M, TC=T2	07716	CEAC10001C
A2R528	315-0104-00		RES, FXD, FILM:100K OHM, 5%, 0.25M	57668	NTR25J-E100K
A2R533	321-0289-03		RES, FXD, FILM:10.0K OHM, 0.25%, 0.125M, TC=T2	07716	CEAC10001C
A2R534	321-0745-03		RES, FXD, FILM:25.05K OHM, 0.125%, 0.125M, TC=T2	19701	5033RC25K05
A2R535	321-0310-00		RES, FXD, FILM:16.5K OHM, 1%, 0.125M, TC=T0	19701	5033ED16K50F
A2R536	321-0769-03		RES, FXD, FILM:50.335 OHM, 0.25%, 0.125M, TC=T2	19701	5033RC50K33C
A2R537	321-0298-00		RES, FXD, FILM:12.4K OHM, 1%, 0.125M, TC=T0	07716	CEAD12401F
A2R541	315-0273-00		RES, FXD, FILM:27K OHM, 5%, 0.25M	57668	NTR25J-E27K0
A2R542	315-0303-00		RES, FXD, FILM:30K OHM, 5%, 0.25M	19701	5043CX30K00J
A2R543	315-0303-00		RES, FXD, FILM:30K OHM, 5%, 0.25M	19701	5043CX30K00J
A2R544	315-0103-00		RES, FXD, FILM:10K OHM, 5%, 0.25M	19701	5043CX10K00J
A2R546	315-0103-00		RES, FXD, FILM:10K OHM, 5%, 0.25M	19701	5043CX10K00J
A2R547	315-0271-00		RES, FXD, FILM:270 OHM, 5%, 0.25M	57668	NTR25J-E270E
A2R548	315-0302-00		RES, FXD, FILM:3K OHM, 5%, 0.25M	57668	NTR25J-E03K0
A2R549	315-0102-00		RES, FXD, FILM:1K OHM, 5%, 0.25M	57668	NTR25J-E01K0
A2R550	311-1265-00		RES, VAR, NONMM:TRMR, 2K OHM, 0.5M	32997	3329P-L58-202
A2R551	315-0102-00		RES, FXD, FILM:1K OHM, 5%, 0.25M	57668	NTR25J-E01K0
A2R552	315-0473-00		RES, FXD, FILM:47K OHM, 5%, 0.25M	57668	NTR25J-E47K0
A2R553	321-0289-00		RES, FXD, FILM:10.0K OHM, 1%, 0.125M, TC=T0	19701	5033ED10K0F
A2R554	321-0265-00		RES, FXD, FILM:5.62K OHM, 1%, 0.125M, TC=T0	19701	5043ED5K620F
A2R555	315-0101-00		RES, FXD, FILM:100 OHM, 5%, 0.25M	57668	NTR25J-E 100E
A2R556	321-0193-00		RES, FXD, FILM:1K OHM, 1%, 0.125M, TC=T0	19701	5033ED1K00F
A2R557	321-0263-00		RES, FXD, FILM:5.36K OHM, 1%, 0.125M, TC=T0	07716	CEAD53600F
A2R558	321-0222-00		RES, FXD, FILM:2.00K OHM, 1%, 0.125M, TC=T0	19701	5033ED2K00F
A2R559	315-0104-00		RES, FXD, FILM:100K OHM, 5%, 0.25M	57668	NTR25J-E100K
A2R561	315-0273-00		RES, FXD, FILM:27K OHM, 5%, 0.25M	57668	NTR25J-E27K0
A2R562	315-0363-00		RES, FXD, FILM:36K OHM, 5%, 0.25M	57668	NTR25J-E36K0
A2R565	321-0289-00		RES, FXD, FILM:10.0K OHM, 1%, 0.125M, TC=T0	19701	5033ED10K0F
A2R567	315-0681-00		RES, FXD, FILM:680 OHM, 5%, 0.25M	57668	NTR25J-E680E
A2R568	315-0682-00		RES, FXD, FILM:6.8K OHM, 5%, 0.25M	57668	NTR25J-E06K8
A2R569	315-0682-00		RES, FXD, FILM:6.8K OHM, 5%, 0.25M	57668	NTR25J-E06K8
A2R572	315-0101-00		RES, FXD, FILM:100 OHM, 5%, 0.25M	57668	NTR25J-E 100E
A2R573	321-0317-00		RES, FXD, FILM:19.6K OHM, 1%, 0.125M, TC=T0	07716	CEAD19601F
A2R574	315-0205-00		RES, FXD, FILM:2M OHM, 5%, 0.25M	01121	CB2055
A2R600	311-1263-00		RES, VAR, NONMM:1K OHM, 10%, 0.50M	32997	3329P-L58-102
A2R601	321-0231-00		RES, FXD, FILM:2.49K OHM, 1%, 0.125M, TC=T0	19701	5033ED2K49F
A2R602	321-0271-00		RES, FXD, FILM:6.49K OHM, 1%, 0.125M, TC=T0	07716	CEAD64900F
A2R603	315-0472-00		RES, FXD, FILM:4.7K OHM, 5%, 0.25M	57668	NTR25J-E04K7
A2R724	315-0102-00		RES, FXD, FILM:1K OHM, 5%, 0.25M	57668	NTR25J-E01K0
A2R734	315-0332-00		RES, FXD, FILM:3.3K OHM, 5%, 0.25M	57668	NTR25J-E03K3
A2R821	315-0100-00		RES, FXD, FILM:10 OHM, 5%, 0.25M	19701	5043CX10RR00J
A2R823	317-0100-00		RES, FXD, CMPSN:10 OHM, 5%, 0.125M	01121	BB1005
A2R824	315-0100-00		RES, FXD, FILM:10 OHM, 5%, 0.25M	19701	5043CX10RR00J
A2R826	315-0100-00		RES, FXD, FILM:10 OHM, 5%, 0.25M	19701	5043CX10RR00J
A2R827	315-0100-00		RES, FXD, FILM:10 OHM, 5%, 0.25M	19701	5043CX10RR00J
A2T400	120-0658-00		XFMR, TOROID:	TK1345	120-0658-00
A2T446	120-0658-00		XFMR, TOROID:	TK1345	120-0658-00
A2U512	155-0035-00		MICROCKT, LINEAR:QUAD OPNL AMPL	80009	155-0035-00
A2U602	156-0053-00		MICROCKT, LINEAR:VOLTAGE REGULATOR	07263	SL21721
A2VR219	152-0279-00		SEMICONO DVC, OI:ZEN, SI, 5.1V, 5%, 0.4M, DO-7	14552	T03810989
A2VR299	152-0127-00		SEMICONO DVC, OI:ZEN, SI, 7.5V, 5%, 0.4M, DO-7	14433	Z5347 (1N9588)
A3	670-1120-05		CIRCUIT BD ASSY:TRIGGER	80009	670-1120-05
A3C14	283-0253-00		CAP, FXD, CER OI:0.01UF, 10%, 100V	04222	15051C103KZT6C
A3C20	281-0812-00		CAP, FXD, CER OI:1000PF, 10%, 100V	04222	MA101C102KAA
A3C25	281-0823-00		CAP, FXD, CER OI:470PF, 10%, 50V	04222	MA105A471KAA
A3C26	283-0121-00		CAP, FXD, CER OI:1000PF, 20%, 200V	91418	5P102M2011958
A3C27	283-0216-00		CAP, FXD, CER OI:1.5PF, +/-0.1PF, 50V	51642	S050050NP01598A
A3C28	283-0175-00		CAP, FXD, CER OI:10PF, 5%, 200V	05397	C312C100D265CA 8

Component No.	Tektronix Part No.	Serial/Assembly No. Effective Dscont	Name & Description	Mfr. Code	Mfr. Part No.
A3C29	283-0154-00		CAP, FXD, CER D1:22PF, 5%, 50V	04222	SR155A220JAA
A3C33	283-0253-00		CAP, FXD, CER D1:0.01UF, 10%, 100V	04222	15051C103KZT6C
A3C37	283-0177-00		CAP, FXD, CER D1:1UF, +80-20%, 25V	04222	SR302E105ZAATR
A3C39	283-0121-00		CAP, FXD, CER D1:1000PF, 20%, 200V	91418	5P102M2011958
A3C43	283-0139-00		CAP, FXD, CER D1:150PF, 20%, 50V	05397	C312C151M5G5CA
A3C48	283-0253-00		CAP, FXD, CER D1:0.01UF, 10%, 100V	04222	15051C103KZT6C
A3C51	283-0121-00		CAP, FXD, CER D1:1000PF, 20%, 200V	91418	5P102M2011958
A3C53	283-0047-00		CAP, FXD, CER D1:270PF, 5%, 500V	59660	0831604Z5F0271J
A3C63	283-0121-00		CAP, FXD, CER D1:1000PF, 20%, 200V	91418	5P102M2011958
A3C68	283-0175-00		CAP, FXD, CER D1:10PF, 5%, 200V	05397	C312C100D265CA 8
A3C73	283-0121-00		CAP, FXD, CER D1:1000PF, 20%, 200V	91418	5P102M2011958
A3C74	283-0141-00		CAP, FXD, CER D1:200PF, 10%, 600V	14193	PD-0321-201K
A3C78	283-0253-00		CAP, FXD, CER D1:0.01UF, 10%, 100V	04222	15051C103KZT6C
A3C81	283-0182-00		CAP, FXD, CER D1:51PF, 5%, 400V	04222	3429 400A 510J
A3C86	283-0121-00		CAP, FXD, CER D1:1000PF, 20%, 200V	91418	5P102M2011958
A3C91	283-0121-00		CAP, FXD, CER D1:1000PF, 20%, 200V	91418	5P102M2011958
A3C92	283-0182-00		CAP, FXD, CER D1:51PF, 5%, 400V	04222	3429 400A 510J
A3C93	283-0177-00		CAP, FXD, CER D1:1UF, +80-20%, 25V	04222	SR302E105ZAATR
A3C97	283-0121-00		CAP, FXD, CER D1:1000PF, 20%, 200V	91418	5P102M2011958
A3C101	285-0719-00		CAP, FXD, PLASTIC:0.015UF, 5%, 100V	19396	DU490/74-28226
A3C104	283-0177-00		CAP, FXD, CER D1:1UF, +80-20%, 25V	04222	SR302E105ZAATR
A3C106	283-0051-00		CAP, FXD, CER D1:0.0033UF, 5%, 100V	04222	SR301A332JAA
A3C108	281-0760-00		CAP, FXD, CER D1:22PF, 10%, 500V	04222	MA107A220KAA
A3C111	281-0763-00		CAP, FXD, CER D1:47PF, 10%, 100V	04222	MA101A470KAA
A3C114	281-0814-00		CAP, FXD, CER D1:100 PF, 10%, 100V	04222	MA101A101KAA
A3C122	283-0121-00		CAP, FXD, CER D1:1000PF, 20%, 200V	91418	5P102M2011958
A3C124	283-0121-00		CAP, FXD, CER D1:1000PF, 20%, 200V	91418	5P102M2011958
A3C127	283-0253-00		CAP, FXD, CER D1:0.01UF, 10%, 100V	04222	15051C103KZT6C
A3C129	290-0135-00		CAP, FXD, ELCTLT:15UF, 20%, 20V	05397	T1108156M020AS
A3C131	281-0762-00		CAP, FXD, CER D1:27PF, 20%, 100V	04222	MA101A270MAA
A3C133	283-0175-00		CAP, FXD, CER D1:10PF, 5%, 200V	05397	C312C100D265CA 8
A3C134	283-0197-00		CAP, FXD, CER D1:470PF, 5%, 50V	04222	SR205A471JAA
A3C137	283-0253-00		CAP, FXD, CER D1:0.01UF, 10%, 100V	04222	15051C103KZT6C
A3C140	283-0432-00		CAP, FXD, CER D1:51PF, 5%, 50V	95275	VJ0805-A-510-J-H
A3C141	283-0175-00		CAP, FXD, CER D1:10PF, 5%, 200V	05397	C312C100D265CA 8
A3C144	281-0767-00		CAP, FXD, CER D1:330PF, 20%, 100V	04222	MA106C331MAA
A3C163	281-0814-00		CAP, FXD, CER D1:100 PF, 10%, 100V	04222	MA101A101KAA
A3C171	281-0762-00		CAP, FXD, CER D1:27PF, 20%, 100V	04222	MA101A270MAA
A3C178	281-0811-00		CAP, FXD, CER D1:10PF, 10%, 100V	04222	MA101A100KAA
A3C182	281-0759-00		CAP, FXD, CER D1:22PF, 10%, 100V	04222	MA101A220KAA
A3C186	281-0762-00		CAP, FXD, CER D1:27PF, 20%, 100V	04222	MA101A270MAA
A3C187	281-0811-00		CAP, FXD, CER D1:10PF, 10%, 100V	04222	MA101A100KAA
A3C191	281-0773-00		CAP, FXD, CER D1:0.01UF, 10%, 100V	04222	MA201C103KAA
A3C810	290-0114-00		CAP, FXD, ELCTLT:47UF, 20%, 6V	05397	T1108476M006AS
A3C811	283-0253-00		CAP, FXD, CER D1:0.01UF, 10%, 100V	04222	15051C103KZT6C
A3C812	290-0135-00		CAP, FXD, ELCTLT:15UF, 20%, 20V	05397	T1108156M020AS
A3C813	281-0773-00		CAP, FXD, CER D1:0.01UF, 10%, 100V	04222	MA201C103KAA
A3C814	290-0135-00		CAP, FXD, ELCTLT:15UF, 20%, 20V	05397	T1108156M020AS
A3C815	290-0296-00		CAP, FXD, ELCTLT:100UF, 20%, 20V	05397	T1100107M020AS
A3C816	283-0253-00		CAP, FXD, CER D1:0.01UF, 10%, 100V	04222	15051C103KZT6C
A3C817	283-0253-00		CAP, FXD, CER D1:0.01UF, 10%, 100V	04222	15051C103KZT6C
A3C818	283-0121-00		CAP, FXD, CER D1:1000PF, 20%, 200V	91418	5P102M2011958
A3C819	283-0204-00		CAP, FXD, CER D1:0.01UF, 20%, 50V	04222	SR155E103MAA
A3CR26	152-0141-02		SEMICOND DVC, D1:5M, S1, 30V, 150MA, 30V	03508	DA2527 (1N4152)
A3CR28	152-0329-00		SEMICOND DVC, D1:TNL, GE, 21MA, 1.5PF, D0-20	53399	SMT0892
A3CR29	152-0140-01		SEMICOND DVC, D1:TNL, GE, 10MA, 8PF, D0-17	03508	SMT0995
A3CR32	152-0141-02		SEMICOND DVC, D1:5M, S1, 30V, 150MA, 30V	03508	DA2527 (1N4152)
A3CR43	152-0246-00		SEMICOND DVC, D1:5M, S1, 40V, 200MA, D0-7	14433	MG1537TK
A3CR44	152-0246-00		SEMICOND DVC, D1:5M, S1, 40V, 200MA, D0-7	14433	MG1537TK

Replaceable Electrical Parts - 7T11A

Component No.	Tektronix Part No.	Serial/Assembly No. Effective Dscont	Name & Description	Mfr. Code	Mfr. Part No.
A3CR51	152-0141-02		SEMICOND OVC,DI:SM,SI,30V,150MA,30V	03508	0A2527 (1N4152)
A3CR63	152-0322-00		SEMICOND OVC,DI:SCHOTTKY BARRIER,SI,15V	50434	5082-2672
A3CR73	152-0322-00		SEMICOND OVC,DI:SCHOTTKY BARRIER,SI,15V	50434	5082-2672
A3CR91	152-0141-02		SEMICOND OVC,DI:SM,SI,30V,150MA,30V	03508	0A2527 (1N4152)
A3CR92	152-0322-00		SEMICOND OVC,DI:SCHOTTKY BARRIER,SI,15V	50434	5082-2672
A3CR95	152-0322-00		SEMICOND OVC,DI:SCHOTTKY BARRIER,SI,15V	50434	5082-2672
A3CR96	152-0322-00		SEMICOND OVC,DI:SCHOTTKY BARRIER,SI,15V	50434	5082-2672
A3CR103	152-0141-02		SEMICOND OVC,DI:SM,SI,30V,150MA,30V	03508	0A2527 (1N4152)
A3CR105	152-0141-02		SEMICOND OVC,DI:SM,SI,30V,150MA,30V	03508	0A2527 (1N4152)
A3CR106	152-0141-02		SEMICOND OVC,DI:SM,SI,30V,150MA,30V	03508	0A2527 (1N4152)
A3CR107	152-0141-02		SEMICOND OVC,DI:SM,SI,30V,150MA,30V	03508	0A2527 (1N4152)
A3CR109	152-0141-02		SEMICOND OVC,DI:SM,SI,30V,150MA,30V	03508	0A2527 (1N4152)
A3CR115	152-0141-02		SEMICOND OVC,DI:SM,SI,30V,150MA,30V	03508	0A2527 (1N4152)
A3CR131	152-0141-02		SEMICOND OVC,DI:SM,SI,30V,150MA,30V	03508	0A2527 (1N4152)
A3CR132	152-0322-00		SEMICOND OVC,DI:SCHOTTKY BARRIER,SI,15V	50434	5082-2672
A3CR134	152-0177-00		SEMICOND OVC,DI:SELECTED	80009	152-0177-00
A3CR142	152-0140-01		SEMICOND OVC,DI:TNL,GE,10MA,8PF,00-17	03508	SMT0995
A3CR149	152-0141-02		SEMICOND OVC,DI:SM,SI,30V,150MA,30V	03508	0A2527 (1N4152)
A3CR152	152-0177-00		SEMICOND OVC,DI:SELECTED	80009	152-0177-00
A3CR172	152-0141-02		SEMICOND OVC,DI:SM,SI,30V,150MA,30V	03508	0A2527 (1N4152)
A3CR181	152-0141-02		SEMICOND OVC,DI:SM,SI,30V,150MA,30V	03508	0A2527 (1N4152)
A3CR185	152-0141-02		SEMICOND OVC,DI:SM,SI,30V,150MA,30V	03508	0A2527 (1N4152)
A3CR191	152-0141-02		SEMICOND OVC,DI:SM,SI,30V,150MA,30V	03508	0A2527 (1N4152)
A3DS136	150-0048-01		LAMP,INCAND:5V,0.06A,#683,AGED & SEL	58854	683A515
A3J11	131-0265-00		CONN,RCPT,ELEC:MINTR,CKT 80 WTD,MALE	98291	051-053-0000
A3J31	131-0265-00		CONN,RCPT,ELEC:MINTR,CKT 80 WTD,MALE	98291	051-053-0000
A3J33	131-0265-00		CONN,RCPT,ELEC:MINTR,CKT 80 WTD,MALE	98291	051-053-0000
A3J162	131-0265-00		CONN,RCPT,ELEC:MINTR,CKT 80 WTD,MALE	98291	051-053-0000
A3J189	131-0265-00		CONN,RCPT,ELEC:MINTR,CKT 80 WTD,MALE	98291	051-053-0000
A3K30	108-0599-00		COIL,REED SM:	80009	108-0599-00
A3K31	108-0599-00		COIL,REED SM:	80009	108-0599-00
A3K32	108-0599-00		COIL,REED SM:	80009	108-0599-00
A3K70	108-0599-00		COIL,REED SM:	80009	108-0599-00
A3K71	108-0599-00		COIL,REED SM:	80009	108-0599-00
A3K80	108-0599-00		COIL,REED SM:	80009	108-0599-00
A3L33	108-0262-00		COIL,RF:FIXED,510NH	80009	108-0262-00
A3L36	276-0543-00		SHLD BEAD,ELEK:FERRITE	80009	276-0543-00
A3L38	276-0543-00		SHLD BEAD,ELEK:FERRITE	80009	276-0543-00
A3L129	120-0382-00		COIL,RF:210UH,+28%-43%,14 TURNS	80009	120-0382-00
A3L188	276-0543-00		SHLD BEAD,ELEK:FERRITE	80009	276-0543-00
A3L189	276-0543-00		SHLD BEAD,ELEK:FERRITE	80009	276-0543-00
A3L814	120-0382-00		COIL,RF:210UH,+28%-43%,14 TURNS	80009	120-0382-00
A3L815	120-0382-00		COIL,RF:210UH,+28%-43%,14 TURNS	80009	120-0382-00
A3Q12	151-0190-00		TRANSISTOR:NPN,SI,TO-92	80009	151-0190-00
A3Q22	151-0302-00		TRANSISTOR:NPN,SI,TO-18	04713	5T899
A3Q26	151-0188-00		TRANSISTOR:PMP,SI,TO-92	80009	151-0188-00
A3Q32	151-0190-00		TRANSISTOR:NPN,SI,TO-92	80009	151-0190-00
A3Q36	151-0202-00		TRANSISTOR:PMP,SI,TO-72	04713	5S2025
A3Q38	151-0202-00		TRANSISTOR:PMP,SI,TO-72	04713	5S2025
A3Q44	151-1011-00		TRANSISTOR:FE,N CHAN,SI,DUAL,TO-71	04713	5FD1011
A3Q50	151-0202-00		TRANSISTOR:PMP,SI,TO-72	04713	5S2025
A3Q62	153-0591-00		SEMICOND OVC SE:MATCHED PAIR	80009	153-0591-00
A3Q72	-----		(PART OF A3Q62)		
A3Q82	151-0268-00		TRANSISTOR:NPN,SI,TO-77	25403	A2607
A3Q92	151-0202-00		TRANSISTOR:PMP,SI,TO-72	04713	5S2025
A3Q102	151-0190-00		TRANSISTOR:NPN,SI,TO-92	80009	151-0190-00
A3Q104	151-0220-00		TRANSISTOR:PMP,SI,TO-92	80009	151-0220-00
A3Q122	151-0202-00		TRANSISTOR:PMP,SI,TO-72	04713	5S2025
A3Q128	151-0212-00		TRANSISTOR:NPN,SI,TO-72	04713	SRF 518

Component No.	Tektronix Part No.	Serial/Assembly No. Effective Dscont	Name & Description	Mfr. Code	Mfr. Part No.
A3Q136	151-0207-00		TRANSISTOR:NPN,SI,X-55,SEL	57668	XD118CP0207
A3Q138	151-0188-00		TRANSISTOR:PMP,SI,TO-92	80009	151-0188-00
A3Q140	151-0268-00		TRANSISTOR:NPN,SI,TO-77	25403	A2607
A3Q144	151-0220-00		TRANSISTOR:PMP,SI,TO-92	80009	151-0220-00
A3Q146	151-0220-00		TRANSISTOR:PMP,SI,TO-92	80009	151-0220-00
A3Q154	151-0220-00		TRANSISTOR:PMP,SI,TO-92	80009	151-0220-00
A3Q156	151-0220-00		TRANSISTOR:PMP,SI,TO-92	80009	151-0220-00
A3Q162	151-0441-00		TRANSISTOR:NPN,SI,TO-72	04713	SRF501
A3Q164	151-0441-00		TRANSISTOR:NPN,SI,TO-72	04713	SRF501
A3Q174	151-0190-00		TRANSISTOR:NPN,SI,TO-92	80009	151-0190-00
A3Q184	151-0271-00		TRANSISTOR:PMP,SI,TO-92	04713	SPS8236
A3Q186	151-0441-00		TRANSISTOR:NPN,SI,TO-72	04713	SRF501
A3Q194	151-1005-00		TRANSISTOR:FET,N-CHAN,SI,TO-106	04713	SPF685
A3Q196	151-0207-00		TRANSISTOR:NPN,SI,X-55,SEL	57668	XD118CP0207
A3R10	311-1267-00		RES,VAR,NONMM:TRMR,5K OHM,0.5M	32997	3329P-L58-502
A3R11	315-0242-00		RES,FXD,FILM:2.4K OHM,5%,0.25M	57668	NTR25J-E02K4
A3R12	315-0152-00		RES,FXD,FILM:1.5K OHM,5%,0.25M	57668	NTR25J-E01K5
A3R13	301-0820-00		RES,FXD,FILM:82 OHM,5%,0.5M	19701	5053CX82R00J
A3R14	317-0047-00		RES,FXD,CMPNSN:4.7 OHM,5%,0.125M	01121	BB47G5
A3R16	315-0752-00		RES,FXD,FILM:7.5K OHM,5%,0.25M	57668	NTR25J-E07K5
A3R17	315-0203-00		RES,FXD,FILM:20K OHM,5%,0.25M	57668	NTR25J-E 20K
A3R18	315-0153-00		RES,FXD,FILM:15K OHM,5%,0.25M	19701	5043CX15K00J
A3R21	301-0470-00		RES,FXD,FILM:47 OHM,5%,0.5M	19701	5053CX47R00J
A3R25	315-0471-00		RES,FXD,FILM:470 OHM,5%,0.25M	57668	NTR25J-E470E
A3R26	317-0472-00		RES,FXD,CMPNSN:4.7K OHM,5%,0.125M	01121	BB4725
A3R27	315-0203-00		RES,FXD,FILM:20K OHM,5%,0.25M	57668	NTR25J-E 20K
A3R28	317-0471-00		RES,FXD,CMPNSN:470 OHM,5%,0.125M	01121	BB4715
A3R30	311-1259-00		RES,VAR,NONMM:TRMR,100 OHM,0.5M	32997	3329P-L58-101
A3R31	301-0750-00		RES,FXD,FILM:75 OHM,5%,0.5M	19701	5053CX75R00J
A3R32	315-0102-00		RES,FXD,FILM:1K OHM,5%,0.25M	57668	NTR25J-E01K0
A3R33	317-0047-00		RES,FXD,CMPNSN:4.7 OHM,5%,0.125M	01121	BB47G5
A3R34	317-0470-00		RES,FXD,CMPNSN:47 OHM,5%,0.125M	01121	BB4705
A3R35	317-0390-00		RES,FXD,CMPNSN:39 OHM,5%,0.125M	01121	BB3905
A3R36	317-0390-00		RES,FXD,CMPNSN:39 OHM,5%,0.125M	01121	BB3905
A3R37	317-0151-00		RES,FXD,CMPNSN:150 OHM,5%,0.125M	01121	BB1515
A3R38	315-0222-00		RES,FXD,FILM:2.2K OHM,5%,0.25M	57668	NTR25J-E02K2
A3R39	317-0361-00		RES,FXD,CMPNSN:360 OHM,5%,0.125M	01121	BB3615
A3R41	317-0271-00		RES,FXD,CMPNSN:270 OHM,5%,0.125M	01121	BB2715
A3R42	321-0481-00		RES,FXD,FILM:1M OHM,1%,0.125M,TC=TO	19701	5043E01M000F
A3R43	317-0474-00		RES,FXD,CMPNSN:470K OHM,5%,0.125M	01121	BB4745
A3R45	311-0607-00		RES,VAR,NONMM:TRMR,10K OHM,0.5M	73138	82-25-2
A3R46	317-0203-00		RES,FXD,CMPNSN:20K OHM,5%,0.125M	01121	BB2035
A3R47	323-0303-00		RES,FXD,FILM:14.0K OHM,1%,0.5M,TC=TO	75042	CECT0-1402F
A3R48	315-0101-00		RES,FXD,FILM:100 OHM,5%,0.25M	57668	NTR25J-E 100E
A3R51	317-0101-00		RES,FXD,CMPNSN:100 OHM,5%,0.125M	01121	BB1015
A3R53	317-0821-00		RES,FXD,CMPNSN:820 OHM,5%,0.125M	01121	BB8215
A3R56	317-0512-00		RES,FXD,CMPNSN:5.1K OHM,5%,0.125M	01121	BB5125
A3R61	307-0987-00		RES,FXD,FILM:51 OHM,5%,.125M,CHIP	01121	BC051R0JT
A3R62	307-0987-00		RES,FXD,FILM:51 OHM,5%,.125M,CHIP	01121	BC051R0JT
A3R64	317-0101-00		RES,FXD,CMPNSN:100 OHM,5%,0.125M	01121	BB1015
A3R65	321-0237-00		RES,FXD,FILM:2.87K OHM,1%,0.125M,TC=TO	07716	CEAD 28700F
A3R68	317-0510-00		RES,FXD,CMPNSN:51 OHM,5%,0.125M	01121	BB5105
A3R69	315-0430-00		RES,FXD,FILM:43 OHM,5%,0.25M	19701	5043CX43R00J
A3R72	307-0987-00		RES,FXD,FILM:51 OHM,5%,.125M,CHIP	01121	BC051R0JT
A3R75	321-0237-00		RES,FXD,FILM:2.87K OHM,1%,0.125M,TC=TO	07716	CEAD 28700F
A3R76	315-0152-00		RES,FXD,FILM:1.5K OHM,5%,0.25M	57668	NTR25J-E01K5
A3R77	307-0987-00		RES,FXD,FILM:51 OHM,5%,.125M,CHIP	01121	BC051R0JT
A3R78	317-0103-00		RES,FXD,CMPNSN:10K OHM,5%,0.125M	01121	BB1035
A3R79	315-0303-00		RES,FXD,FILM:30K OHM,5%,0.25M	19701	5043CX30K00J

Replaceable Electrical Parts - 7T11A

Component No.	Tektronix Part No.	Serial/Assembly No. Effective Dscont	Name & Description	Mfr. Code	Mfr. Part No.
A3R80	311-1272-00		RES,VAR,NONMH:TRMR,100K OHM,0.5M	32997	3329P-L58-104
A3R81	317-0511-00		RES,FXD,CMPSN:510 OHM,5%,0.125M	01121	885115
A3R83	317-0154-00		RES,FXD,CMPSN:150K OHM,5%,0.125	01121	881545
A3R84	317-0223-00		RES,FXD,CMPSN:22K OHM,5%,0.125M	01121	882235
A3R85	317-0511-00		RES,FXD,CMPSN:510 OHM,5%,0.125M	01121	885115
A3R86	317-0101-00		RES,FXD,CMPSN:100 OHM,5%,0.125M	01121	881015
A3R87	317-0562-00		RES,FXD,CMPSN:5.6K OHM,5%,0.125	01121	885625
A3R88	317-0362-00		RES,FXD,CMPSN:3.6K OHM,5%,0.125M	01121	883625
A3R91	317-0100-00		RES,FXD,CMPSN:10 OHM,5%,0.125M	01121	881005
A3R92	317-0131-00		RES,FXD,CMPSN:130 OHM,5%,0.125M	01121	881315
A3R93	317-0101-00		RES,FXD,CMPSN:100 OHM,5%,0.125M	01121	881015
A3R94	317-0821-00		RES,FXD,CMPSN:820 OHM,5%,0.125M	01121	888215
A3R96	317-0472-00		RES,FXD,CMPSN:4.7K OHM,5%,0.125M	01121	884725
A3R97	317-0101-00		RES,FXD,CMPSN:100 OHM,5%,0.125M	01121	881015
A3R103	315-0202-00		RES,FXD,FILM:2K OHM,5%,0.25M	57668	NTR25J-E 2K
A3R104	315-0433-00		RES,FXD,FILM:43K OHM,5%,0.25M	19701	5043CX43K00J
A3R105	315-0912-00		RES,FXD,FILM:9.1K OHM,5%,0.25M	57668	NTR25J-E09K1
A3R108	315-0101-00		RES,FXD,FILM:100 OHM,5%,0.25M	57668	NTR25J-E 100E
A3R109	315-0912-00		RES,FXD,FILM:9.1K OHM,5%,0.25M	57668	NTR25J-E09K1
A3R111	315-0682-00		RES,FXD,FILM:6.8K OHM,5%,0.25M	57668	NTR25J-E06K8
A3R113	315-0432-00		RES,FXD,FILM:4.3K OHM,5%,0.25M	57668	NTR25J-E04K3
A3R114	315-0182-00		RES,FXD,FILM:1.8K OHM,5%,0.25M	57668	NTR25J-E1K8
A3R116	315-0242-00		RES,FXD,FILM:2.4K OHM,5%,0.25M	57668	NTR25J-E02K4
A3R117	315-0153-00		RES,FXD,FILM:15K OHM,5%,0.25M	19701	5043CX15K00J
A3R118	315-0472-00		RES,FXD,FILM:4.7K OHM,5%,0.25M	57668	NTR25J-E04K7
A3R120	311-1263-00		RES,VAR,NONMH:1K OHM,10%,0.50M	32997	3329P-L58-102
A3R121	308-0292-00		RES,FXD,MM:2.2K OHM,5%,3M	07088	KM300 2201J
A3R122	317-0512-00		RES,FXD,CMPSN:5.1K OHM,5%,0.125	01121	885125
A3R123	317-0202-00		RES,FXD,CMPSN:2K OHM,5%,0.125M	01121	882025
A3R124	317-0511-00		RES,FXD,CMPSN:510 OHM,5%,0.125M	01121	885115
A3R125	321-0233-00		RES,FXD,FILM:2.61K OHM,1%,0.125M,TC=TO	07716	CEA026100F
A3R126	321-0155-00		RES,FXD,FILM:402 OHM,1%,0.125M,TC=TO	07716	CEA0402R0F
A3R127	317-0101-00		RES,FXD,CMPSN:100 OHM,5%,0.125M	01121	881015
A3R128	321-0226-00		RES,FXD,FILM:2.21K OHM,1%,0.125M,TC=TO	01121	RNK2211F
A3R129	315-0100-00		RES,FXD,FILM:10 OHM,5%,0.25M	19701	5043CX10RR00J
A3R130	317-0510-00		RES,FXD,CMPSN:51 OHM,5%,0.125M	01121	885105
A3R131	315-0472-00		RES,FXD,FILM:4.7K OHM,5%,0.25M	57668	NTR25J-E04K7
A3R132	317-0680-00		RES,FXD,CMPSN:68 OHM,5%,0.125M	01121	886805
A3R133	317-0430-00		RES,FXD,CMPSN:43 OHM,5%,0.125M	01121	884305
A3R134	321-0275-00		RES,FXD,FILM:7.15K OHM,1%,0.125M,TC=TO	07716	CEA071500F
A3R135	311-0634-00		RES,VAR,NONMH:TRMR,500 OHM,0.5M	32997	3329H-L58-501
A3R136	307-0230-00		PHOTOELECTRIC C:6900A PEAK	03911	CL1352
A3R137	315-0432-00		RES,FXD,FILM:4.3K OHM,5%,0.25M	57668	NTR25J-E04K3
A3R138	321-0210-00		RES,FXD,FILM:1.50K OHM,1%,0.125M,TC=TO	19701	5033E01K50F
A3R139	315-0100-00		RES,FXD,FILM:10 OHM,5%,0.25M	19701	5043CX10RR00J
A3R140	317-0303-00		RES,FXD,CMPSN:30K OHM,5%,0.125M	01121	883035
A3R141	317-0100-00		RES,FXD,CMPSN:10 OHM,5%,0.125M	01121	881005
A3R143	317-0181-00		RES,FXD,CMPSN:180 OHM,5%,0.125M	01121	881815
A3R144	317-0102-00		RES,FXD,CMPSN:1K OHM,5%,0.125M	01121	881025
A3R145	311-1261-00		RES,VAR,NONMH:TRMR,500 OHM,0.5M	32997	3329P-L58-501
A3R146	323-0204-00		RES,FXD,FILM:1.30K OHM,1%,0.5M,TC=TO	19701	5053R01K300F
A3R147	315-0271-00		RES,FXD,FILM:270 OHM,5%,0.25M	57668	NTR25J-E270E
A3R148	315-0151-00		RES,FXD,FILM:150 OHM,5%,0.25M	57668	NTR25J-E150E
A3R149	315-0153-00		RES,FXD,FILM:15K OHM,5%,0.25M	19701	5043CX15K00J
A3R151	317-0510-00		RES,FXD,CMPSN:51 OHM,5%,0.125M	01121	885105
A3R152	317-0910-00		RES,FXD,CMPSN:91 OHM,5%,0.125M	01121	889105
A3R154	317-0102-00		RES,FXD,CMPSN:1K OHM,5%,0.125M	01121	881025
A3R155	311-1263-00		RES,VAR,NONMH:1K OHM,10%,0.50M	32997	3329P-L58-102
A3R156	323-0212-00		RES,FXD,FILM:1.58K OHM,1%,0.5M,TC=TO	19701	5053R01K580F

Component No.	Tektronix Part No.	Serial/Assembly No. Effective Dscont	Name & Description	Mfr. Code	Mfr. Part No.
A3R157	315-0271-00		RES,FXD,FILM:270 OHM,5%,0.25M	57668	NTR25J-E270E
A3R158	315-0151-00		RES,FXD,FILM:150 OHM,5%,0.25M	57668	NTR25J-E150E
A3R159	315-0202-00		RES,FXD,FILM:2K OHM,5%,0.25M	57668	NTR25J-E 2K
A3R161	317-0101-00		RES,FXD,CMPSPN:100 OHM,5%,0.125M	01121	8B1015
A3R163	315-0822-00		RES,FXD,FILM:8.2K OHM,5%,0.25M	19701	5043CX8K200J
A3R164	315-0153-00		RES,FXD,FILM:15K OHM,5%,0.25M	19701	5043CX15K00J
A3R165	315-0271-00		RES,FXD,FILM:270 OHM,5%,0.25M	57668	NTR25J-E270E
A3R167	315-0182-00		RES,FXD,FILM:1.8K OHM,5%,0.25M	57668	NTR25J-E1K8
A3R171	315-0622-00		RES,FXD,FILM:6.2K OHM,5%,0.25M	19701	5043CX6K200J
A3R172	315-0303-00		RES,FXD,FILM:30K OHM,5%,0.25M	19701	5043CX30K00J
A3R174	315-0162-00		RES,FXD,FILM:1.6K OHM,5%,0.25M	19701	5043CX1K600J
A3R176	301-0912-00		RES,FXD,FILM:9.1K OHM,5%,0.5M	19701	5053CX9K100J
A3R178	315-0203-00		RES,FXD,FILM:20K OHM,5%,0.25M	57668	NTR25J-E 20K
A3R182	315-0103-00		RES,FXD,FILM:10K OHM,5%,0.25M	19701	5043CX10K00J
A3R184	315-0751-00		RES,FXD,FILM:750 OHM,5%,0.25M	57668	NTR25J-E750E
A3R185	315-0102-00		RES,FXD,FILM:1K OHM,5%,0.25M	57668	NTR25JE01K0
A3R186	315-0751-00		RES,FXD,FILM:750 OHM,5%,0.25M	57668	NTR25J-E750E
A3R187	315-0330-00		RES,FXD,FILM:33 OHM,5%,0.25M	19701	5043CX33R00J
A3R188	315-0132-00		RES,FXD,FILM:1.3K OHM,5%,0.25M	57668	NTR25J-E01K3
A3R191	315-0102-00		RES,FXD,FILM:1K OHM,5%,0.25M	57668	NTR25JE01K0
A3R192	315-0107-00		RES,FXD,FILM:100M OHM,5%,0.25M	01121	CB1075
A3R194	315-0153-00		RES,FXD,FILM:15K OHM,5%,0.25M	19701	5043CX15K00J
A3R811	315-0101-00		RES,FXD,FILM:100 OHM,5%,0.25M	57668	NTR25J-E 100E
A3R812	131-0566-00		BUS,COND:DUMMY RES,0.094 OD X 0.225L	24546	OWA 07
A3R817	315-0101-00		RES,FXD,FILM:100 OHM,5%,0.25M	57668	NTR25J-E 100E
A3R818	317-0101-00		RES,FXD,CMPSPN:100 OHM,5%,0.125M	01121	8B1015
A3S1	260-1237-00		SWITCH,REED:SPST,NO. (PART OF K30)	15636	ORDER BY DESCR
A3S1	260-1237-00		SWITCH,REED:SPST,NO. (PART OF K31)	15636	ORDER BY DESCR
A3S1	260-1237-00		SWITCH,REED:SPST,NO. (PART OF K32)	15636	ORDER BY DESCR
A3S1	260-1237-00		SWITCH,REED:SPST,NO. (PART OF K70)	15636	ORDER BY DESCR
A3S1	260-1237-00		SWITCH,REED:SPST,NO. (PART OF K71)	15636	ORDER BY DESCR
A3S1	260-0721-00		SWITCH,REED:SPDT,35A TURN (PART OF K80)	12617	1152234160
A3U20	156-0053-00		MICROCKT,LINEAR:VOLTAGE REGULATOR	07263	SL21721
A3U110	156-0030-03		MICROCKT,DGTL:QUAD 2 INPUT NAND GATE,SCRN	18324	N7400(NB OR FB)
A3VR104	152-0395-00		SEMICONV DVC,DI:ZEN,SI,4.3V,5%,0.4M	04713	SZG35009K18
A3VR107	152-0395-00		SEMICONV DVC,DI:ZEN,SI,4.3V,5%,0.4M	04713	SZG35009K18
A4	670-1121-04		CIRCUIT BD ASSY:INTERFACE	80009	670-1121-04
A4C100	290-0267-00		CAP,FXD,ELCTLT:1UF,20%,35V (C100A)	05397	T320A105M035AS
A4C100	290-0188-00		CAP,FXD,ELCTLT:0.1UF,10%,35V (C100B)	05397	T322A104K035AS
A4C100	283-0239-00		CAP,FXD,CER DI:0.022UF,10%,50V (C100C)	04222	3439-050C-223K
A4C290	295-0127-00		CAP SET,MATCHED:0.5UF,0.05UF,0.00495UF, (A4C290A,C,D,E)	80009	295-0127-00
A4C318	295-0128-00		CAP SET,MATCHED:3.05UF,0.00495UF,450PF (C318A THRU C318C) (C318D SELECTED AND ADDED IF NECESSARY)	80009	295-0128-00
A4C802	290-0135-00		CAP,FXD,ELCTLT:15UF,20%,20V	05397	T1108156M020AS
A4C803	290-0114-00		CAP,FXD,ELCTLT:47UF,20%,6V	05397	T1108476M006AS
A4C804	290-0135-00		CAP,FXD,ELCTLT:15UF,20%,20V	05397	T1108156M020AS
A4C822	290-0135-00		CAP,FXD,ELCTLT:15UF,20%,20V	05397	T1108156M020AS
A4C825	290-0135-00		CAP,FXD,ELCTLT:15UF,20%,20V	05397	T1108156M020AS
A4L802	120-0382-00		COIL,RF:210UH,+28%-43%,14 TURNS	80009	120-0382-00



Replaceable Electrical Parts - 7T11A

Component No.	Tektronix Part No.	Serial/Assembly No. Effective Dscont	Name & Description	Mfr. Code	Mfr. Part No.
A4L803	120-0382-00		COIL,RF:210UH,+28%-43%,14 TURNS	80009	120-0382-00
A4L804	108-0538-00		COIL,RF:FIXED,2.7UH	76493	JMM#87059
A4R317	317-0510-00		RES,FXD,CMPSN:51 OHM,5%,0.125M	01121	885105
A4R318	317-0101-00		RES,FXD,CMPSN:100 OHM,5%,0.125M	01121	881015
A4R530	311-1018-00		RES,VAR,NONWH:PNL,2X20K OHM,0.5M	01121	G07632
A4R580	321-0293-00		RES,FXD,FILM:11.0K OHM,1%,0.125M,TC=TO (R580A)	07716	CEAD11001F
A4R580	321-0381-00		RES,FXD,FILM:90.9K OHM,1%,0.125M,TC=TO (R580B)	07716	CEAD09091F
A4R580	321-0289-00		RES,FXD,FILM:10.0K OHM,1%,0.125M,TC=TO (R580C)	19701	5033ED10K0F
A4R580	321-0481-00		RES,FXD,FILM:1M OHM,1%,0.125M,TC=TO (R580D)	19701	5043ED1M000F
A4R648	315-0203-00		RES,FXD,FILM:20K OHM,5%,0.25M	57668	NTR25J-E 20K
A4R649	315-0102-00		RES,FXD,FILM:1K OHM,5%,0.25M	57668	NTR25JE01K0
A4R678	315-0153-00		RES,FXD,FILM:15K OHM,5%,0.25M	19701	5043CX15K00J
A4R681	315-0271-00		RES,FXD,FILM:270 OHM,5%,0.25M	57668	NTR25J-E270E
A4R685	316-0102-00		RES,FXD,CMPSN:1K OHM,10%,0.25M	01121	CB1021
A4R741	321-0402-00		RES,FXD,FILM:150K OHM,1%,0.125M,TC=TO	19701	5033ED150K0F
A4R742	321-0373-00		RES,FXD,FILM:75.0K OHM,1%,0.125M,TC=TO	19701	5033ED75K00F
A4R744	321-0373-00		RES,FXD,FILM:75.0K OHM,1%,0.125M,TC=TO	19701	5033ED75K00F
A4R745	321-0402-00		RES,FXD,FILM:150K OHM,1%,0.125M,TC=TO	19701	5033ED150K0F
A4R747	321-0373-00		RES,FXD,FILM:75.0K OHM,1%,0.125M,TC=TO	19701	5033ED75K00F
A4R748	321-0402-00		RES,FXD,FILM:150K OHM,1%,0.125M,TC=TO	19701	5033ED150K0F
A4R751	321-0402-00		RES,FXD,FILM:150K OHM,1%,0.125M,TC=TO	19701	5033ED150K0F
A4R752	321-0373-00		RES,FXD,FILM:75.0K OHM,1%,0.125M,TC=TO	19701	5033ED75K00F
A4R754	321-0402-00		RES,FXD,FILM:150K OHM,1%,0.125M,TC=TO	19701	5033ED150K0F
A4R755	321-0344-00		RES,FXD,FILM:37.4K OHM,1%,0.125M,TC=TO	19701	5033ED 37K40F
A4R756	321-0373-00		RES,FXD,FILM:75.0K OHM,1%,0.125M,TC=TO	19701	5033ED75K00F
A4R759	315-0753-00		RES,FXD,FILM:75K OHM,5%,0.25M	57668	NTR25J-E75K0
A4R761	321-0373-00		RES,FXD,FILM:75.0K OHM,1%,0.125M,TC=TO	19701	5033ED75K00F
A4R762	321-0402-00		RES,FXD,FILM:150K OHM,1%,0.125M,TC=TO	19701	5033ED150K0F
A4R764	321-0356-00		RES,FXD,FILM:49.9K OHM,1%,0.125M,TC=TO	19701	5033ED49K90F
A4R765	321-0344-00		RES,FXD,FILM:37.4K OHM,1%,0.125M,TC=TO	19701	5033ED 37K40F
A4R766	321-0335-00		RES,FXD,FILM:30.1K OHM,1%,0.125M,TC=TO	57668	R814FXE30K1
A4R771	301-0472-00		RES,FXD,FILM:4.7K OHM,5%,0.5M	19701	5053CX4K700J
A4S530	105-0329-00		ACTR ASSY,CAM S:TIME/CM	80009	105-0329-00
A4S530	105-0330-00		(S530A.SEE RMPL FOR REPLACEMENT PARTS) ACTR ASSY,CAM S:SWEEP RANGE (S530B.SEE MPL FOR REPLACEMENT PARTS)	80009	105-0330-00
A4S531	-----		(A4S531A THRU C,PART OF BOARD ASSY)		
A5	670-1195-01		CIRCUIT BD ASSY:TRIGGER AMPLIFIER SM	80009	670-1195-01
A50S80	150-0048-01		LAMP,INCAND:5V,0.06A,#683,AGED & SEL	58854	683AS15
A5S80	-----		(PART OF BOARD ASSEMBLY)		
A6	670-1196-01		CIRCUIT BD ASSY:TRIGGER SOURCE SM	80009	670-1196-01
A60S30	150-0048-01		LAMP,INCAND:5V,0.06A,#683,AGED & SEL	58854	683AS15
A6R57	317-0102-00		RES,FXD,CMPSN:1K OHM,5%,0.125M	01121	881025
A6S30	-----		(PART OF BOARD ASSEMBLY)		
A7	670-1197-01		CIRCUIT BD ASSY:SCAN SM	80009	670-1197-01
A7CR609	152-0141-02		SEMICOND DVC,DI:5M,51,30V,150MA,30V	03508	0A2527 (1N4152)
A70S610	150-0048-01		LAMP,INCAND:5V,0.06A,#683,AGED & SEL	58854	683AS15
A7R609	317-0103-00		RES,FXD,CMPSN:10K OHM,5%,0.125M	01121	881035
A7S610	-----		(PART OF BOARD ASSEMBLY)		
A8	670-1198-01		CIRCUIT BD ASSY:SLOPE SM	80009	670-1198-01
A80S70	150-0048-01		LAMP,INCAND:5V,0.06A,#683,AGED & SEL	58854	683AS15
A8S70	-----		(PART OF BOARD ASSEMBLY)		

Component No.	Tektronix Part No.	Serial/Assembly No. Effective Dscont	Name & Description	Mfr. Code	Mfr. Part No.
A9	670-1199-01		CIRCUIT BD ASSY:RANDOM SEQUENCE SM	80009	670-1199-01
A9DS20	150-0048-01		LAMP, INCAND:5V,0.06A,#683,AGED & SEL	58854	683AS15
A9R220	317-0102-00		RES,FXD,CMPSN:1K OHM,5%,0125M	01121	8B1025
A9S220	-----		(PART OF BOARD ASSEMBLY)		
A10	670-1184-00		CIRCUIT BD ASSY:COMMUTATOR SM FIXED	80009	670-1184-00
C570	283-0004-00		CAP,FXD,CER DI:0.02UF,+80-20%,150V	59660	855-55875V0203Z
CR136	152-0141-02		SEMICOND DVC,DI:SM,SI,30V,150MA,30V	03508	DA2527 (1N4152)
J10	131-0888-00		CONN,PLUG,ELEC:3MM,MALE	26805	2031-5006-95
J190	131-0579-00		CONN,RCPT,ELEC:MINTR BAYONET,MALE	24931	38JS106-1
J569	131-0779-00		JACK,TIP:U/M 0.08 OD TEST POINT	98291	0168010000208
J610	131-0779-00		JACK,TIP:U/M 0.08 OD TEST POINT	98291	0168010000208
R70	311-1081-00		RES,VAR,NONMH:PNL,2X10K OHM,2M	71590	8A02660002
R570	311-0965-01		RES,VAR,NONMH:PNL,(2)10K OHM,20%,0.5M	12697	CM43475
R610	311-0467-00		RES,VAR,NONMH:PNL,100K OHM,0.5M	01121	M77058
R679	311-0487-00		RES,VAR,NONMH:PNL,30K OHM,0.5M	01121	M-7706
R680	311-0387-00		RES,VAR,NONMH:PNL,5K OHM,0.5M	01121	M7565A

# SECTION 8

## DIAGRAMS AND CIRCUIT BOARD ILLUSTRATIONS

### Symbols and Reference Designators

Electrical components shown on the diagrams are in the following units unless noted otherwise:

- Capacitors = Values one or greater are in picofarads (pF).  
Values less than one are in microfarads ( $\mu$ F).
- Resistors = Ohms ( $\Omega$ ).

Graphic symbols and class designation letters are based on ANSI Standard Y32.2-1975.

Logic symbology is based on ANSI Y32.14-1973 in terms of positive logic. Logic symbols depict the logic function performed and may differ from the manufacturer's data.

The overline on a signal name indicates that the signal performs its intended function when it goes to the low state.

Abbreviations are based on ANSI Y1.1-1972.

Other ANSI standards that are used in the preparation of diagrams by Tektronix, Inc. are:

- Y14.15, 1966 Drafting Practices.
- Y14.2, 1973 Line Conventions and Lettering.
- Y10.5, 1968 Letter Symbols for Quantities Used in Electrical Science and Electrical Engineering.

— The information and special symbols below may appear in this manual. —

### Assembly Numbers

Each assembly in the instrument is assigned an assembly number (e.g., A20). The assembly number appears on the circuit board outline on the diagram and in the title for the circuit board component location illustration. The Replaceable Electrical Parts list is arranged by assemblies in numerical sequence, with each assembly's components listed by component number in alphanumeric sequence \*(see accompanying illustration for constructing a component number).

#### \* COMPONENT NUMBER EXAMPLE

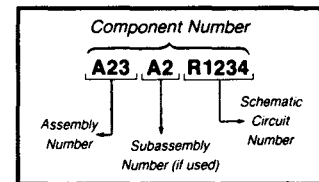

Chassis-mounted components have no Assembly Number prefix—see end of Replaceable Electrical Parts List

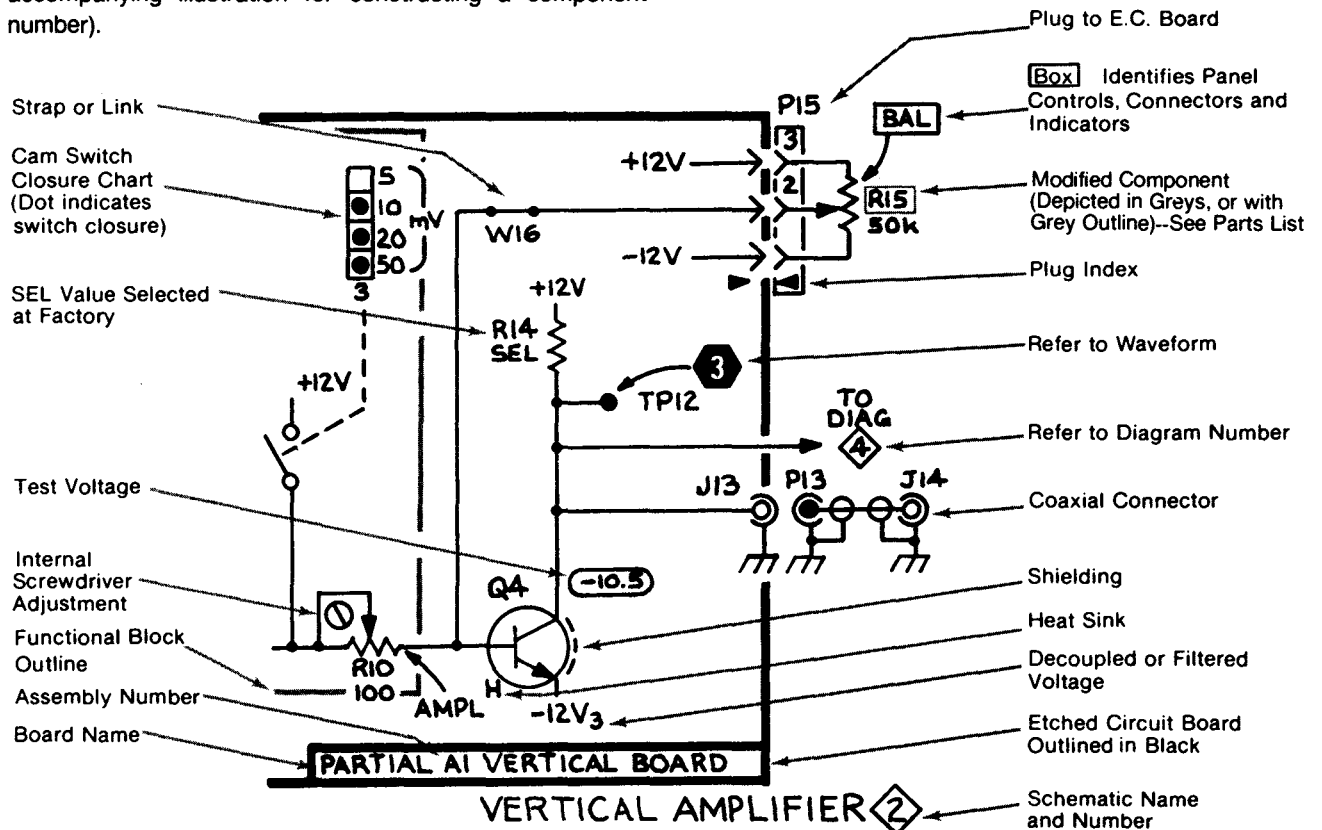

**NOTE**  
**LEAD CONFIGURATIONS AND CASE STYLES ARE TYPICAL, BUT MAY VARY DUE TO VENDOR CHANGES OR INSTRUMENT MODIFICATIONS.**

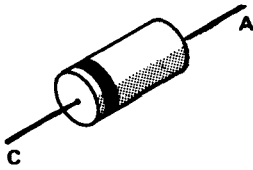

SIGNAL DIODE

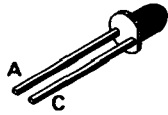

LIGHT EMITTING DIODE (L.E.D.)

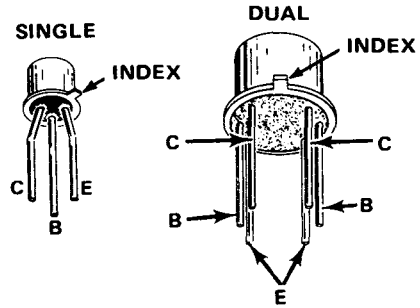

METAL CASE TRANSISTORS

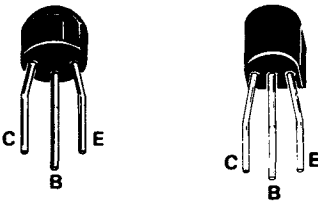

PLASTIC CASE TRANSISTORS

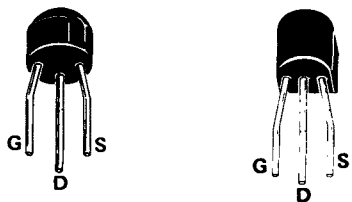

PLASTIC CASE FETS

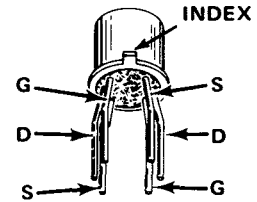

DUAL METAL CASE FET

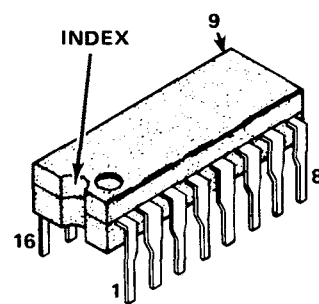
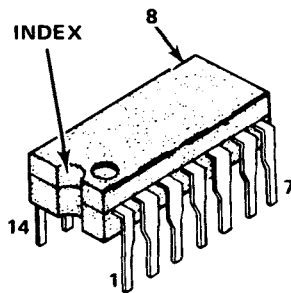
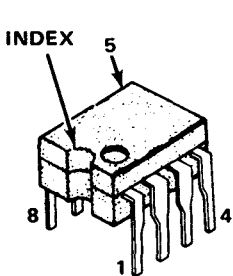

INTEGRATED CIRCUITS

Figure 8-1. Semiconductor lead configurations.

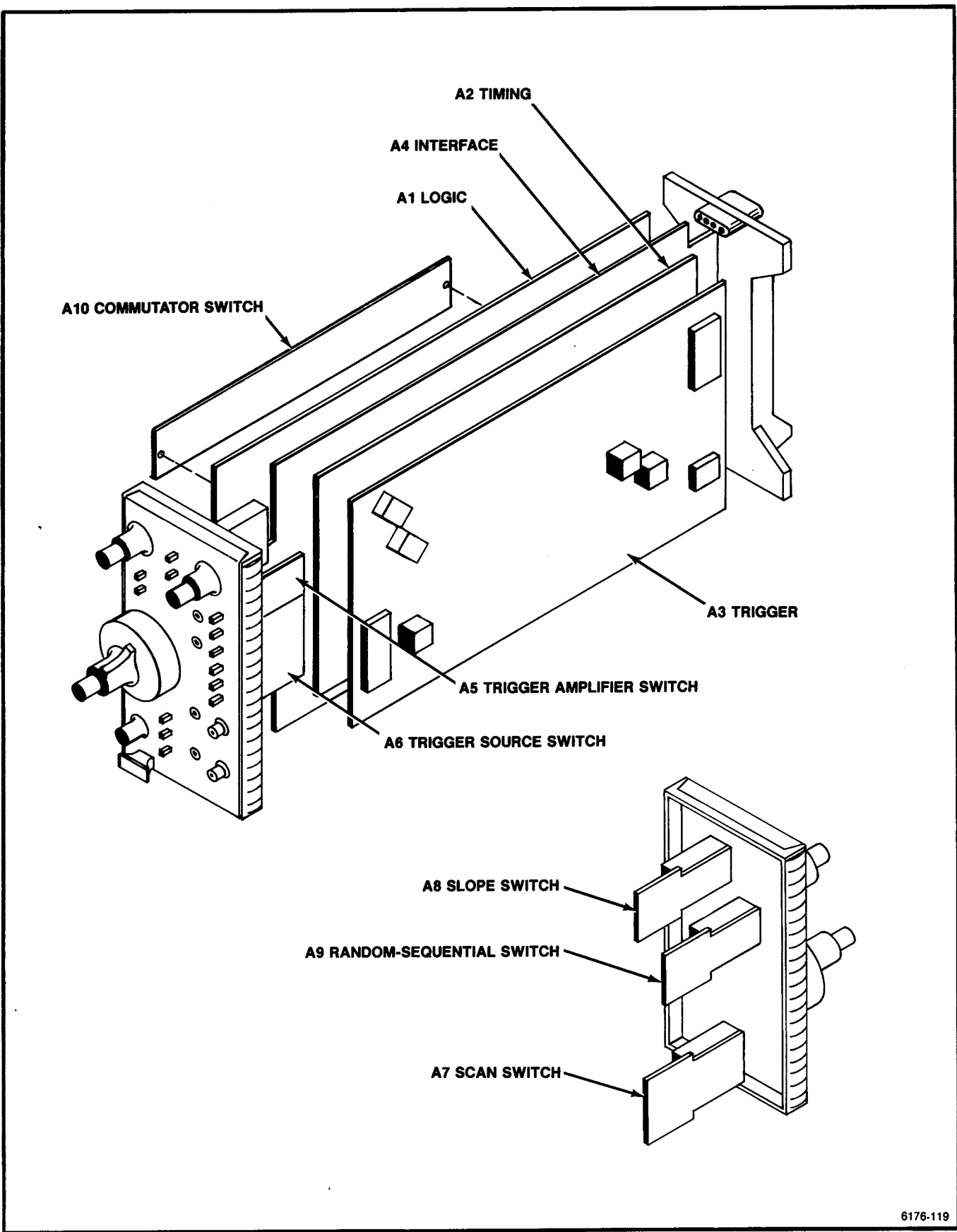

6176-119

Figure 8-2. Location of circuit boards in the 7T11A.

7T11A

## VOLTAGE AND WAVEFORM TEST CONDITIONS

The typical voltage measurements were obtained under the following conditions unless noted otherwise on the individual diagrams:

Voltmeter		Oscilloscope Mainframe	
Type	Multimeter	Vertical Mode	Left
Sensitivity	20,000 ohm/volt	Horizontal Mode	B
Ranges	0.6 and 12 volts	B Intensity	Optimum
		A Trigger Source	Right Vert
		B Trigger Source	Left Vert

Sampling Unit (right vertical compartment, calibrated Sampling Head installed)	
Input to Sampling Head	No input signal

7T11A (left horizontal compartment)	
SLOPE	+
STABILITY	Fully clockwise (free run)
SEQUENTIAL	Pushed in
TIME POS RNG	5 $\mu$ s
TIME/DIV	.5 $\mu$ s
SCAN pushbutton	REP
SCAN control	Fully cw
TIME POSITION control	Midposition

Differential Comparator (left vertical compartment, 10X probe used for waveforms)	
Volts	+
+ Input	DC
- Input	GND
Volts/Div	See waveforms
Position	Display centered with + Input grounded

Time Base (right horizontal compartment)	
Mode	Auto P-P Auto
Coupling	AC
Source	Int
Magnifier	X1
Time/Div	See Waveforms

All voltages given on the diagrams are in volts. Waveforms shown are actual waveform photographs taken with a Tektronix Oscilloscope Camera System. Vertical deflection factor shown on waveform is the actual deflection factor from the input connector and does not include the 10X attenuation of the probe. The voltages and waveforms on the diagrams are not absolute and may vary between instruments because of component tolerances, internal calibration, or front panel control settings. Voltage and time readouts are simulated in larger-than-normal type. Waveforms with the notation "Ext Trig" were taken with the Time Base externally triggered from the 7T11A PULSE OUT connector. Notations below the waveforms, other than "Ext Trig", refer to 7T11A control settings.

1

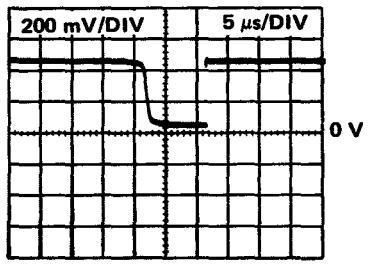

TRIGGER INPUT

1

2

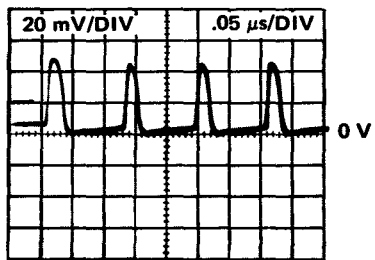

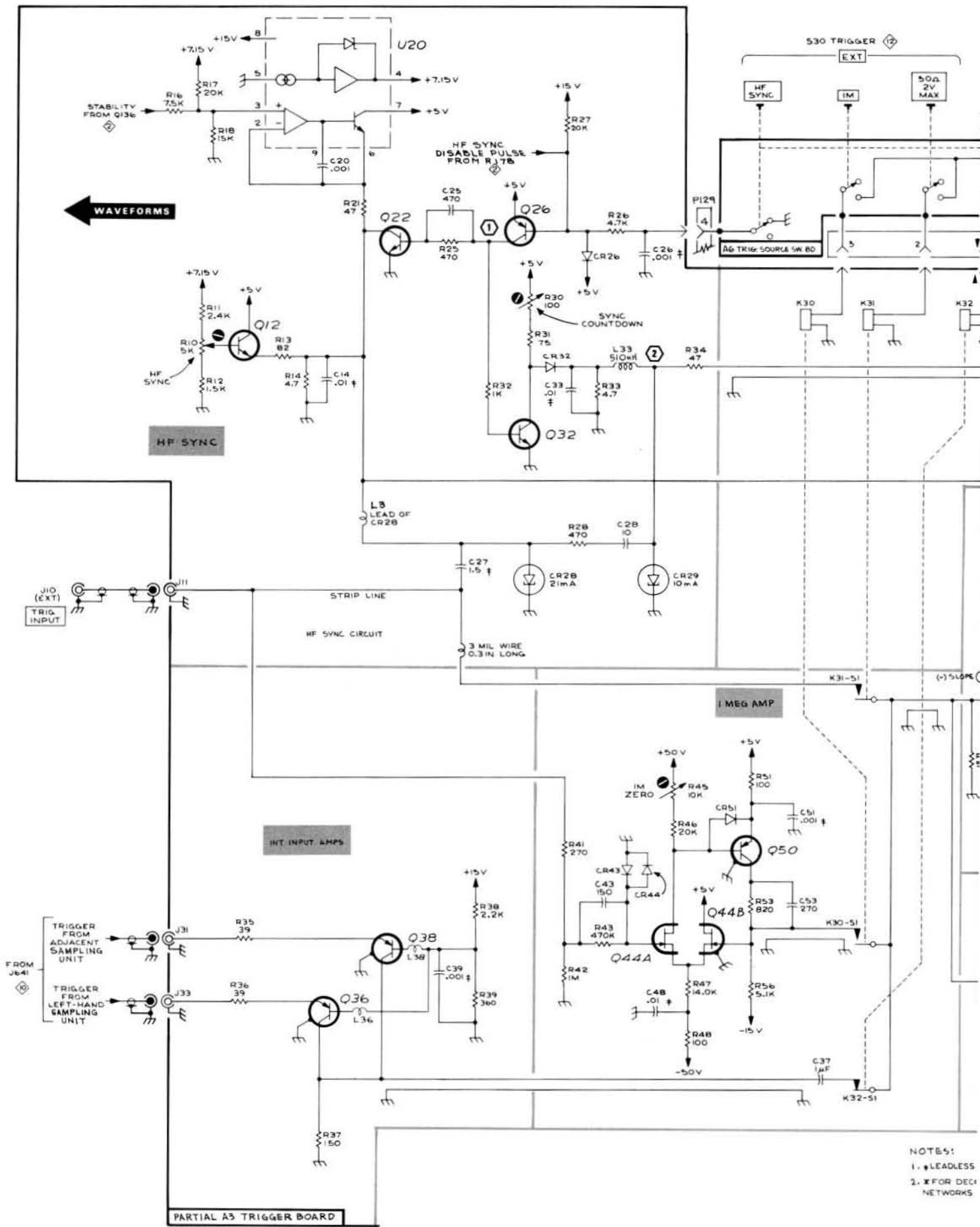

NOTES:  
 1. † LEADLESS  
 2. X FOR DEC NETWORKS



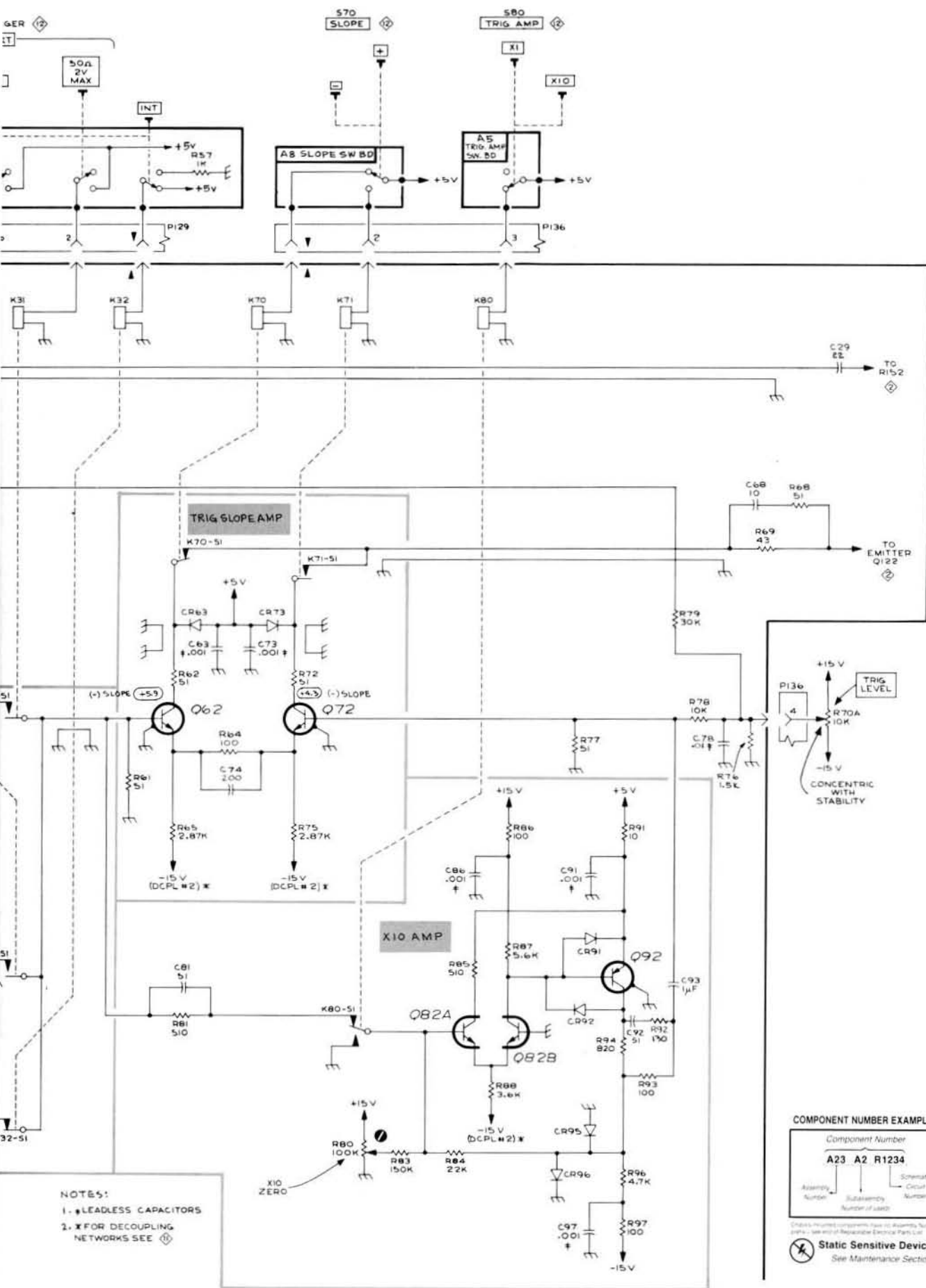

TRIGGER INPUT

NOTES:  
 1. LEADLESS CAPACITORS  
 2. X FOR DECOUPLING NETWORKS SEE

COMPONENT NUMBER EXAMPLE

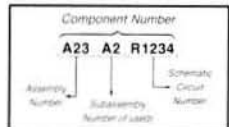

Circle X marked components have no Assembly Number. See end of Repairable Electrical Parts List.  
 Static Sensitive Devices  
 See Maintenance Section

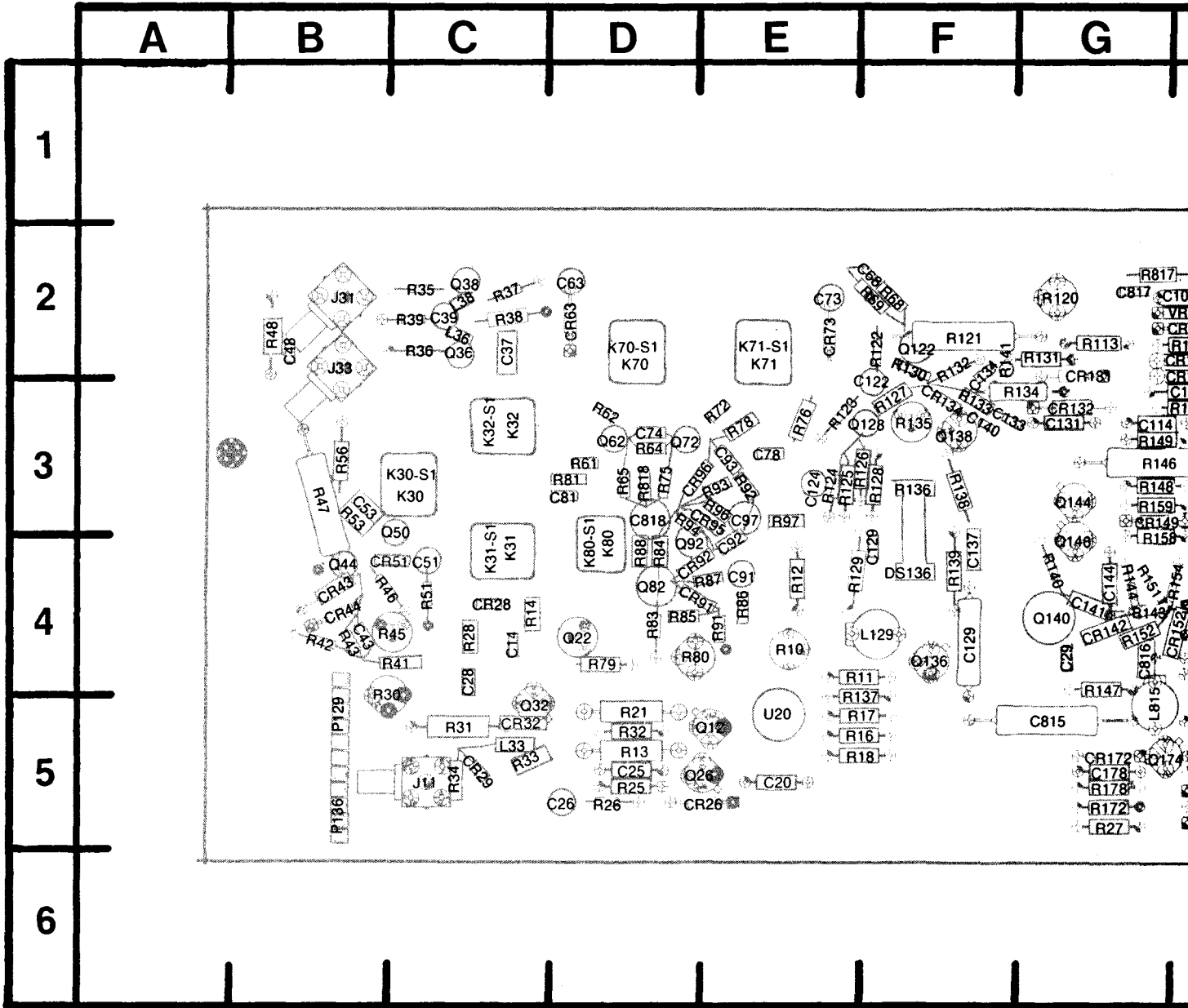

COMPONENT NUMBER EXAMPLE

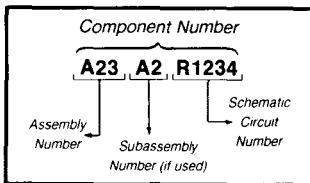
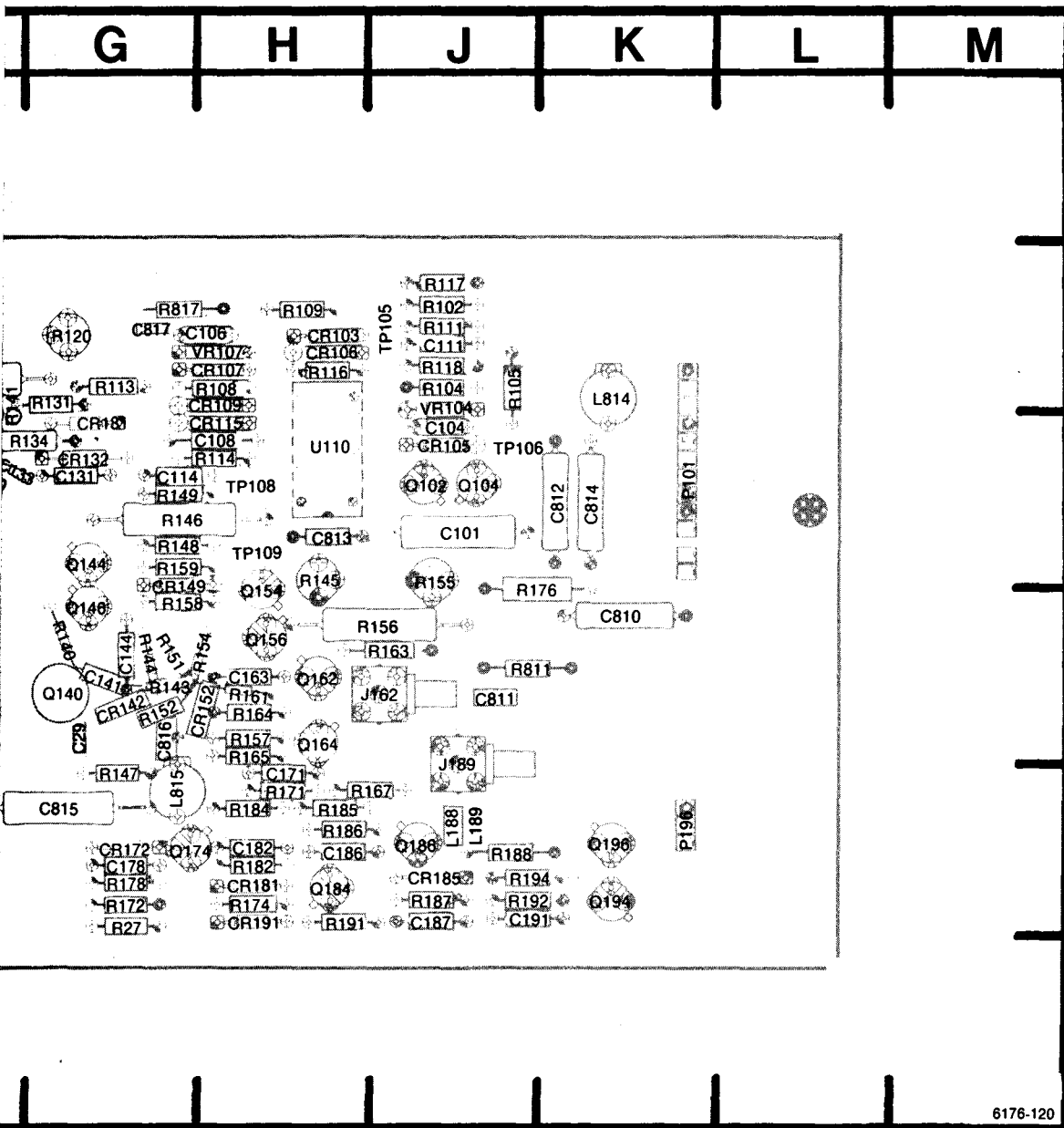

Figure 8-3. A3-Trigger circuit

Chassis-mounted components have no Assembly Number prefix—see end of Replaceable Electrical Parts List

**Static Sensitive Devices**  
See Maintenance Section



6176-120

Figure 8-3. A3-Trigger circuit board assembly.

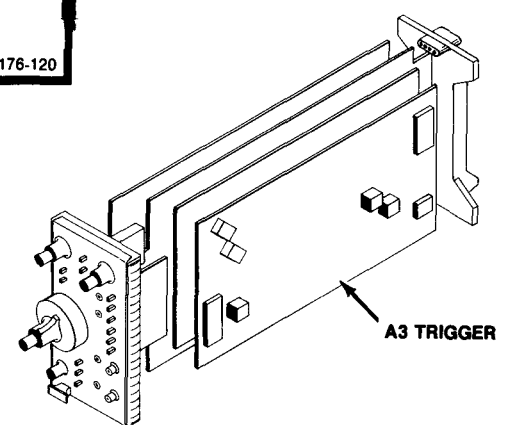

CIRCUIT NUMBER	GRID COORD.	CIRCUIT NUMBER	GRID COORD.	CIRCUIT NUMBER	GRID COORD.	CIRCUIT NUMBER	GRID COORD.	CIRCUIT NUMBER	GRID COORD.
C14	C4	CR73	E2	Q50	B3	R72	E3	R156	H4
C20	E5	CR91	D4	Q62	D3	R75	D3	R157	H4
C25	D5	CR92	D4	Q72	D3	R76	E3	R158	G3
C26	D5	CR95	E3	Q82	D4	R78	E3	R159	G3
C28	C4	CR96	D3	Q92	D3	R79	D4	R161	H4
C29	G4	CR103	H2	Q102	J3	R80	D4	R163	H4
C37	C2	CR105	J3	Q104	J3	R81	D3	R164	H4
C39	C2	CR106	H2	Q122	F2	R83	D4	R165	H4
C43	B4	CR107	G2	Q128	E3	R84	D4	R167	H4
C48	B2	CR109	G2	Q136	F4	R85	D4	R171	H4
C51	C4	CR115	G2	Q138	F3	R86	E4	R172	G5
C53	B3	CR131	G2	Q140	G4	R87	D4	R174	H5
C63	D2	CR132	G3	Q144	G3	R88	D4	R176	J3
C68	E2	CR134	F3	Q146	G3	R91	E4	R178	G5
C73	E2	CR142	G4	Q154	H3	R92	E3	R182	H5
C74	D3	CR149	G3	Q156	H4	R93	E3	R184	H5
C78	E3	CR152	G4	Q162	H4	R94	D3	R185	H5
C81	D3	CR172	G5	Q164	H4	R96	E3	R186	H5
C91	E4	CR181	H5	Q174	G5	R97	E3	R187	J5
C92	E3	CR185	J5	Q184	H5	R102	J2	R188	J5
C93	E3	CR191	H5	Q186	J5	R104	J2	R191	H5
C97	E3			Q194	K5	R105	J2	R192	J5
C101	J3	DS136	F4	Q196	K5	R108	G2	R194	J5
C104	J2					R109	H2	R811	J4
C106	G2	J11	C5	R10	E4	R111	J2	R817	G2
C108	G3	J31	B2	R11	E4	R113	G2	R818	D3
C111	J2	J33	B2	R12	E4	R114	G3	TP105	H2
C114	G3	J162	H4	R13	D5	R116	H2	TP106	J3
C122	E2	J189	J4	R14	C4	R117	J2	TP108	H3
C124	E3			R16	E5	R118	J2	TP109	H3
C129	F4	K30-S1	C3	R17	E5	R120	G2	U20	E5
C131	G3	K30	C3	R18	E5	R121	F2	U110	H3
C133	F3	K31-S1	C4	R21	D5	R122	E2	VR104	J2
C134	F2	K31	C4	R25	D5	R123	E3	VR107	G2
C137	F4	K32-S1	C3	R26	D5	R124	E3		
C140	F3	K32	C3	R27	G5	R125	E3		
C141	G4	K70-S1	D2	R28	C4	R126	E3		
C144	G4	K70	D2	R30	B4	R127	F3		
C163	H4	K71-S1	E2	R31	C5	R128	E3		
C171	H4	K71	E2	R32	D5	R129	E4		
C178	G5	K80-S1	D4	R33	C5	R130	F2		
C182	H5	K80	D4	R34	C5	R131	G2		
C186	H5			R35	C2	R132	F2		
C187	J5	L33	C5	R36	C2	R133	F3		
C191	J5	L36	C2	R37	C2	R134	F2		
C810	K4	L38	C2	R38	C2	R135	F3		
C811	J4	L129	F4	R39	C2	R136	F3		
C812	J3	L188	J5	R41	B4	R137	E4		
C813	H3	L189	J5	R42	B4	R138	F3		
C814	K3	L814	K2	R43	B4	R139	F4		
C815	G5	L815	G4	R45	B4	R140	G4		
C816	G4			R46	B4	R141	F2		
C817	G2	P101	K3	R47	B3	R143	G4		
C818	D3	P129	B5	R48	B2	R144	G4		
		P136	B5	R51	C4	R145	H3		
		P196	K5	R53	B3	R146	G3		
CR26	D5			R56	B3	R147	G4		
CR28	C4	Q12	D5	R61	D3	R148	G3		
CR29	C5	Q22	D4	R62	D3	R149	G3		
CR32	C5	Q26	D5	R64	D3	R151	G4		
CR43	B4	Q32	C5	R65	D3	R152	G4		
CR44	B4	Q36	C2	R68	F2	R154	G4		
CR51	B4	Q38	C2	R69	E2	R155	J3		
CR63	D2	Q44	B4						

2 MA  
T

D

1-\*

2-X

3

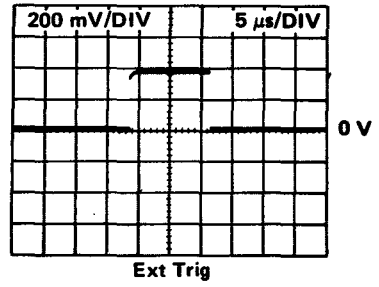
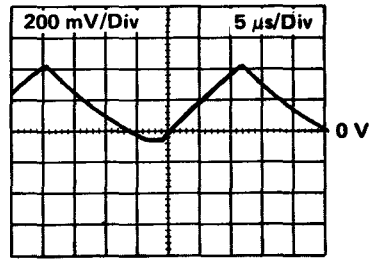

5

4

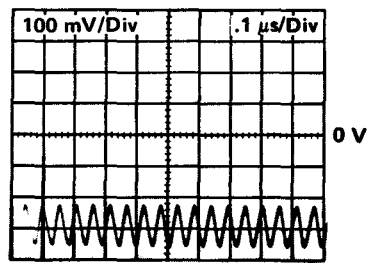
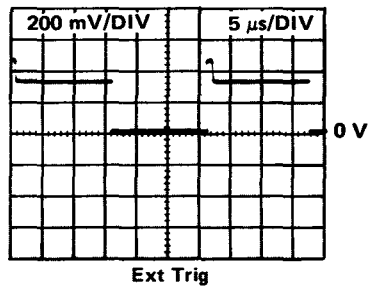

6

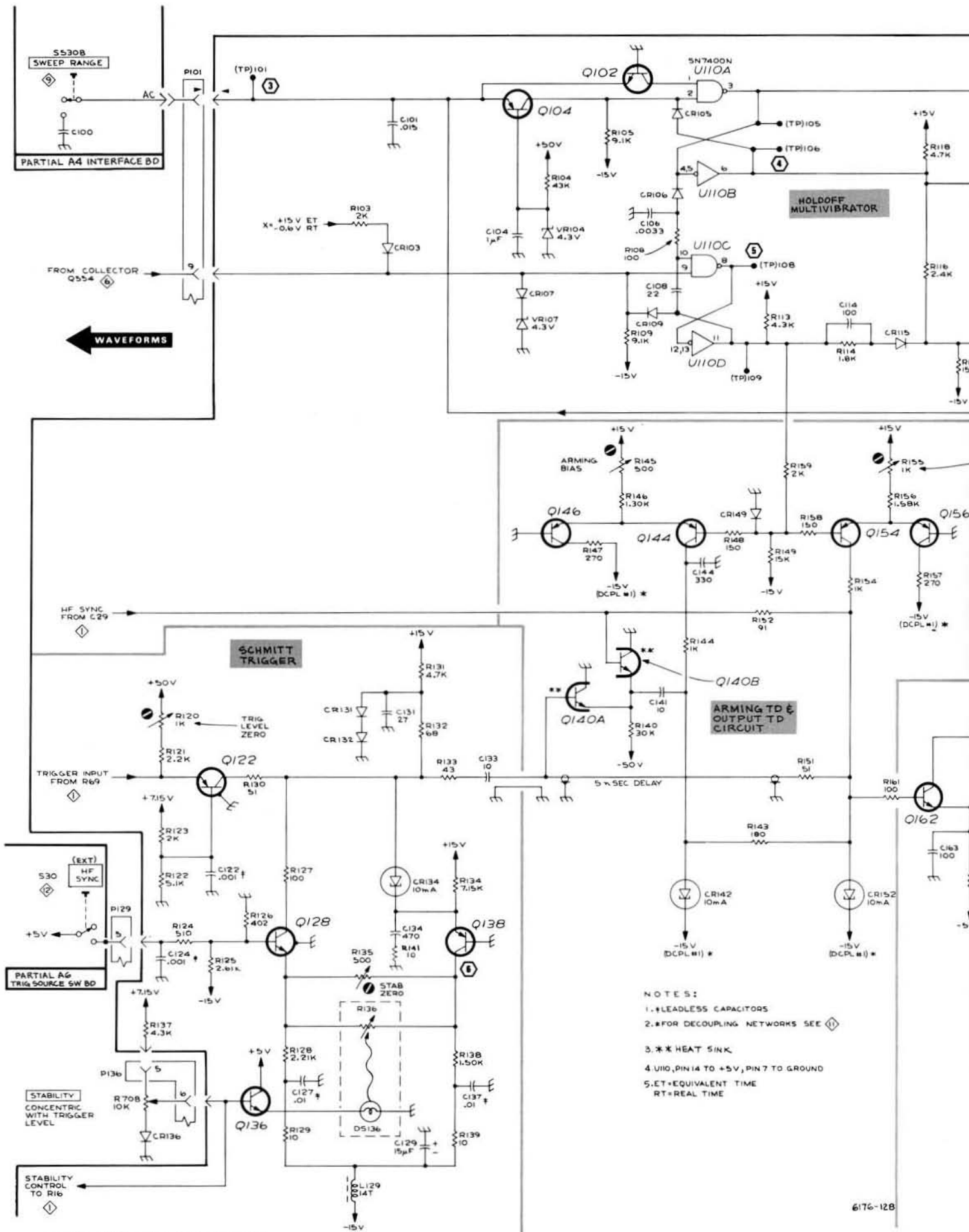

- NOTES:
1. † LEADLESS CAPACITORS
  2. ‡ FOR DECOUPLING NETWORKS SEE ◊
  3. \* HEAT SINK
  4. U110, PIN 14 TO +5V, PIN 7 TO GROUND
  5. ET = EQUIVALENT TIME  
RT = REAL TIME

TT11A SAMPLING SWEEP UNIT

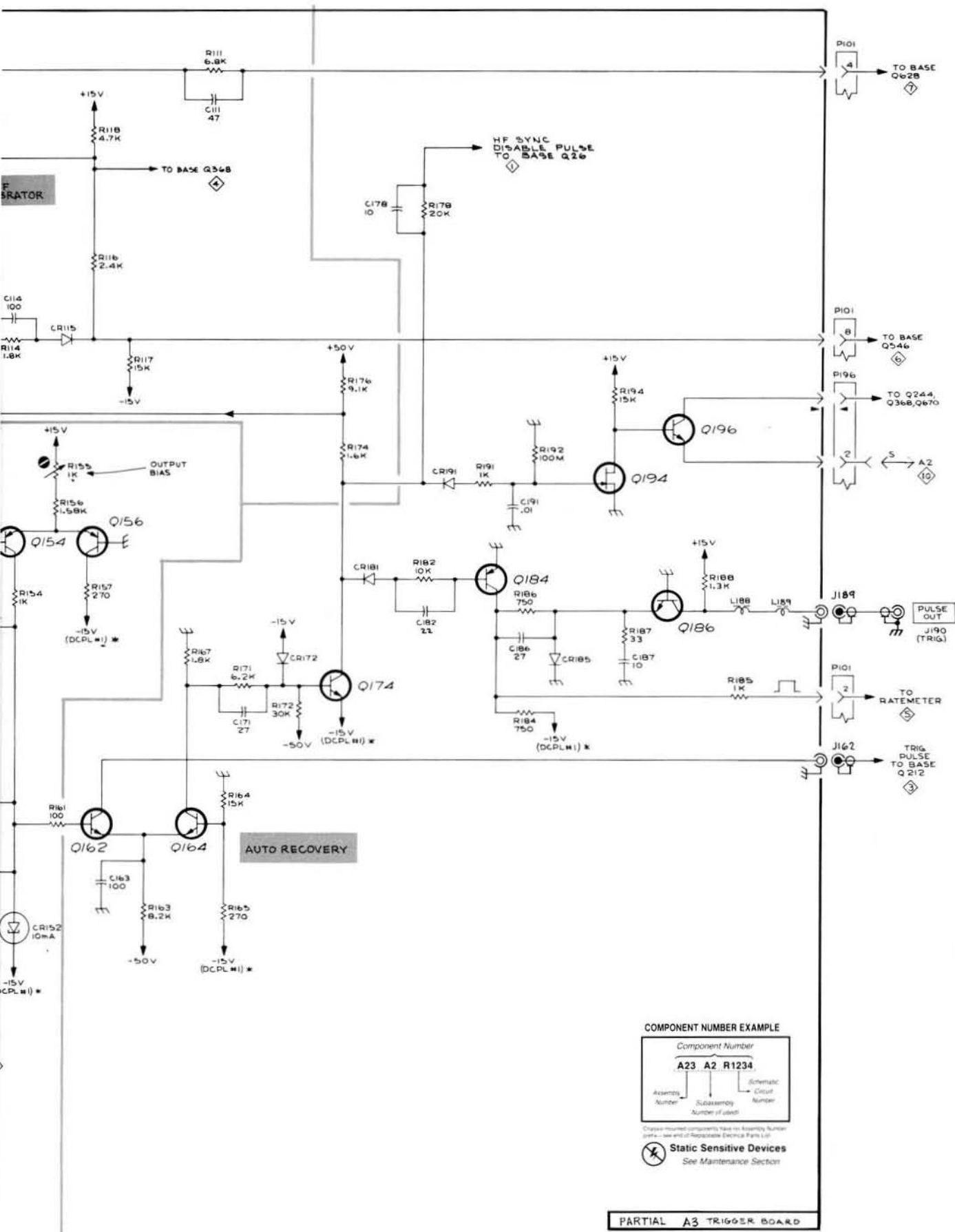

TRIGGER & HOLDOFF



COMPONENT NUMBER EXAMPLE

Component Number		
A23	A2	R1234
Assembly Number	Subassembly Number of used	Schematic Diagram Number

Chassis-mounted components have no Assembly Number (A#) - see end of Separate Electronics Parts List

**Static Sensitive Devices**  
See Maintenance Section

PARTIAL A3 TRIGGER BOARD

TRIGGER & HOLDOFF

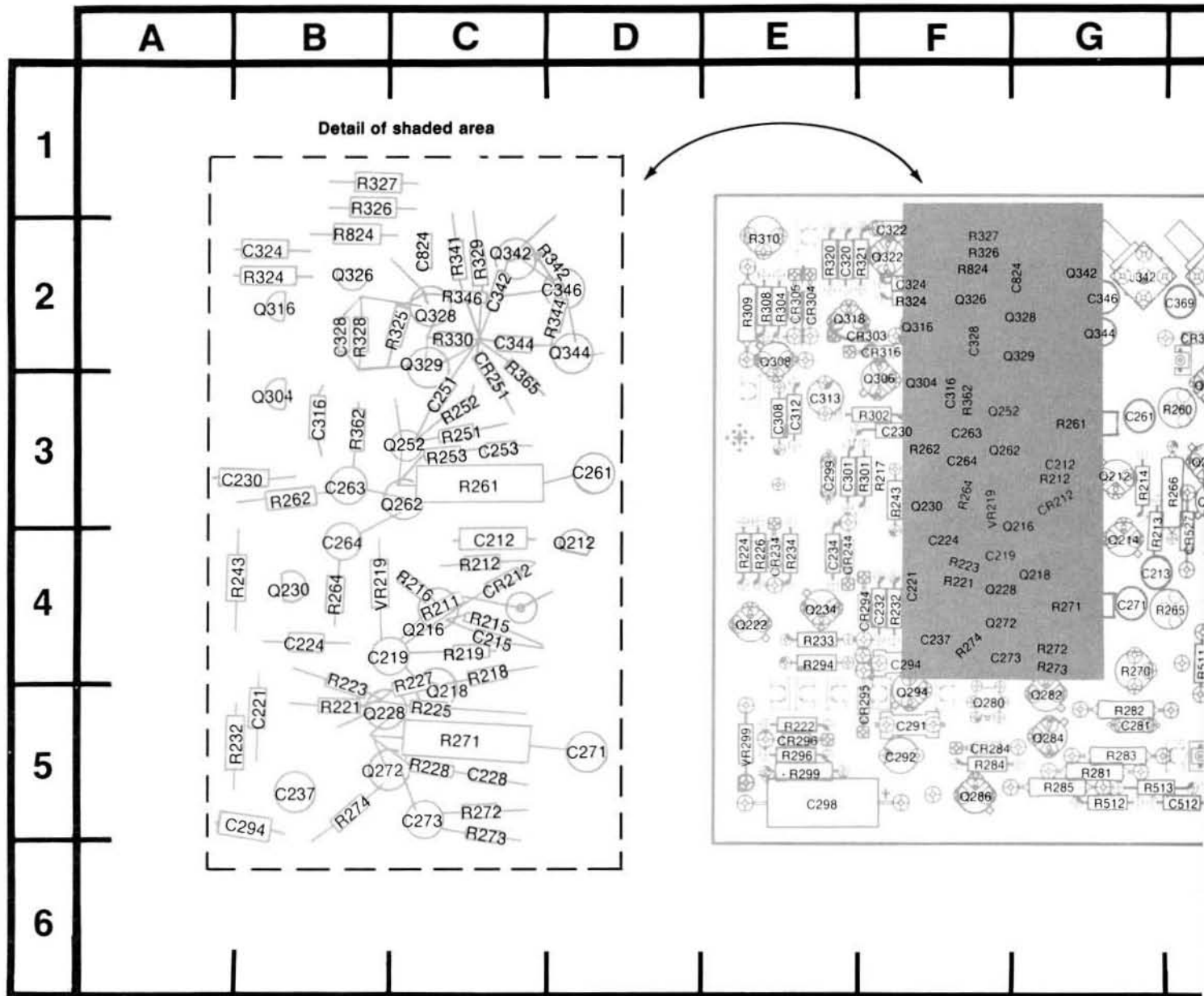
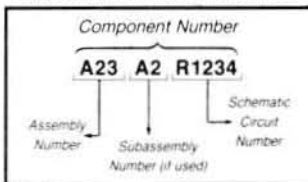

Figure 8-4. A2-Timing circuit board

COMPONENT NUMBER EXAMPLE



Chassis-mounted components have no Assembly Number prefix — see end of Replaceable Electrical Parts List

**Static Sensitive Devices**  
 See Maintenance Section



G      H      J      K      L      M      N      P

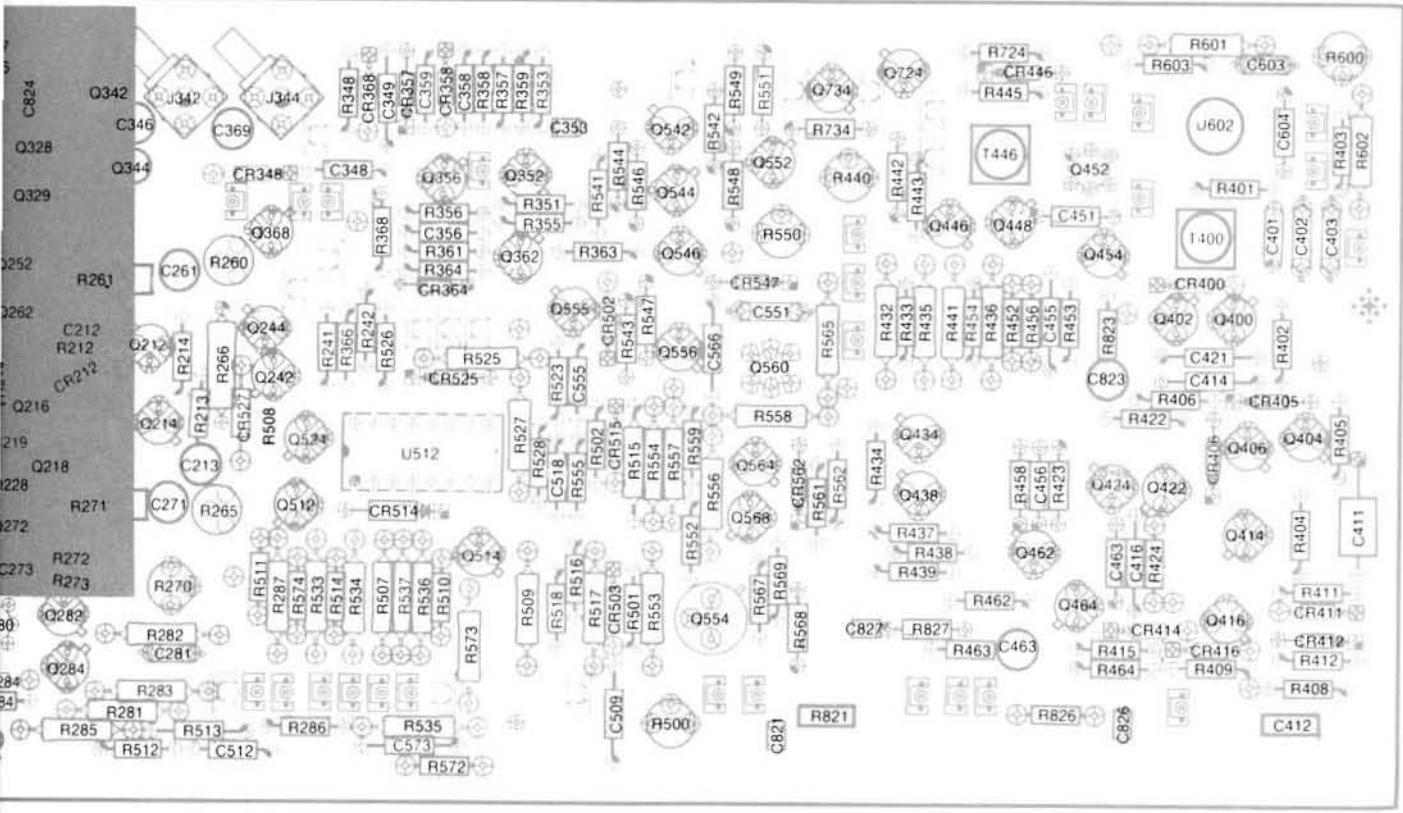

6176-121

4. A2-Timing circuit board assembly.

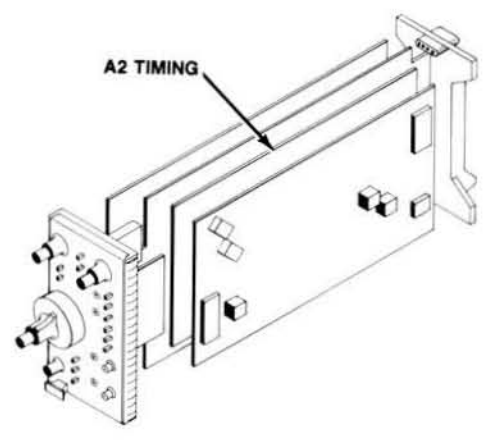

CIRCUIT NUMBER	GRID COORD.	CIRCUIT NUMBER	GRID COORD.	CIRCUIT NUMBER	GRID COORD.	CIRCUIT NUMBER	GRID COORD.	CIRCUIT NUMBER	GRID COORD.	CIRCUIT NUMBER	GRID COORD.
C212	C4	C824	C2	Q328	C2	R253	C3	R415	M5	R558	K4
C213	G4	C826	M5	Q329	C2	R260	H3	R422	M4	R559	K4
C215	C4	C827	L5	Q342	C2	R261	C3	R423	M4	R561	L4
C219	B4			Q344	D2	R262	B3	R424	M4	R562	L4
C221	B5	CR212	C4	Q352	J2	R264	B4	R432	L3	R565	L3
C224	B4	CR234	E4	Q356	J2	R265	G4	R433	L3	R567	K4
C228	C5	CR244	E4	Q362	J3	R266	H3	R434	L4	R568	L5
C230	B3	CR251	C2	Q368	H3	R270	G4	R435	L3	R569	K4
C232	F4	CR284	F5	Q400	N3	R271	C5	R436	M3	R572	J5
C234	E4	CR294	F4	Q402	M3	R272	C5	R437	L4	R573	J5
C237	B5	CR295	F5	Q404	N4	R273	C5	R438	L4	R574	H4
C251	C3	CR296	E5	Q406	N4	R274	B5	R439	L4	R600	N2
C253	C3	CR303	F2	Q414	N4	R281	G5	R440	L2	R601	N2
C261	D3	CR304	E2	Q416	N5	R282	G5	R441	L3	R602	N2
C263	B3	CR305	E2	Q422	M4	R283	G5	R442	L2	R603	M2
C264	B4	CR316	F2	Q424	M4	R284	F5	R443	L2	R724	M2
C271	D5	CR348	H2	Q434	L4	R285	G5	R445	M2	R734	L2
C273	C5	CR357	H2	Q438	L4	R286	H5	R452	M3	R821	L5
C281	G5	CR358	J2	Q446	L3	R287	H4	R453	M3	R823	M3
C291	F5	CR364	J3	Q448	M3	R294	E4	R454	L3	R824	B2
C292	F5	CR368	H2	Q452	M2	R296	E5	R456	M3	R826	M5
C294	B5	CR400	N3	Q454	M3	R299	E5	R458	M4	R827	L5
C298	E5	CR405	N3	Q462	M4	R301	F3	R462	M4		
C299	E3	CR406	N4	Q464	M4	R302	F3	R463	L5	T400	N3
C301	E3	CR411	N5	Q512	H4	R304	E2	R464	M5	T446	M2
C308	E3	CR412	N5	Q514	J4	R308	E2	R500	K5		
C312	E3	CR414	M5	Q524	H4	R309	E2	R501	K5	U512	J4
C313	E3	CR416	N5	Q542	K2	R310	E2	R502	J4	U602	N2
C316	B3	CR446	M2	Q544	K2	R320	E2	R507	H4		
C320	E2	CR502	K3	Q546	K3	R321	F2	R508	H4	VR219	B4
C322	F2	CR503	K5	Q552	K2	R324	B2	R509	J4	VR299	E5
C324	B2	CR514	H4	Q554	K5	R325	C2	R510	J4		
C328	B2	CR515	K4	Q555	J3	R326	B1	R511	H4		
C342	C2	CR525	J3	Q556	K3	R327	B1	R512	G5		
C344	C2	CR527	H4	Q560	K3	R328	B2	R513	G5		
C346	D2	CR547	K3	Q564	K4	R329	C2	R514	H4		
C348	H2	CR562	L4	Q568	K4	R330	C2	R515	K4		
C349	H2			Q724	L2	R341	C2	R516	J4		
C353	J2	J342	G2	Q734	L2	R342	D2	R517	J4		
C356	J3	J344	H2			R344	D2	R518	J4		
C358	J2			R211	C4	R346	C2	R523	J3		
C359	J2	Q212	D4	R212	C4	R348	H2	R525	J3		
C369	H2	Q214	G4	R213	G4	R351	J2	R526	H3		
C401	N3	Q216	C4	R214	G3	R353	J2	R527	J4		
C402	N3	Q218	C5	R215	C4	R355	J3	R528	J4		
C403	N3	Q222	E4	R216	C4	R356	J2	R533	H4		
C411	N4	Q228	B5	R216	C4	R357	J2	R534	H4		
C412	N5	Q230	B4	R217	F3	R358	J2	R535	J5		
C414	N3	Q234	E4	R218	C4	R359	J2	R536	J4		
C416	M4	Q242	H3	R219	C4	R361	J3	R537	H4		
C421	N3	Q244	H3	R221	B5	R362	B3	R541	J2		
C451	M2	Q252	C3	R222	E5	R363	J3	R542	K2		
C455	M3	Q262	C3	R223	B4	R364	J3	R543	K3		
C456	M4	Q272	B5	R224	E4	R365	C2	R544	K2		
C463	M4	Q280	F5	R225	C5	R366	H3	R546	K2		
C509	K5	Q282	G5	R226	E4	R368	H3	R547	K3		
C512	H5	Q284	G5	R227	C4	R401	N2	R548	K2		
C518	J4	Q286	F5	R228	C5	R402	N3	R549	K2		
C551	K3	Q294	F5	R232	B5	R403	N2	R550	K3		
C555	J3	Q304	B3	R233	E4	R404	N4	R551	K2		
C566	K3	Q306	F3	R234	E4	R405	N4	R552	K4		
C573	J5	Q308	E2	R241	H3	R406	M3	R553	K5		
C603	N2	Q316	B2	R242	H3	R408	N5	R554	K4		
C604	N2	Q318	E2	R243	B4	R409	N5	R555	J4		
C821	K5	Q322	F2	R251	C3	R411	N4	R556	K4		
C823	M3	Q326	B2	R252	C3	R412	N5	R557	K4		

7

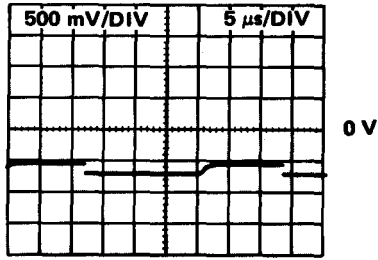

10

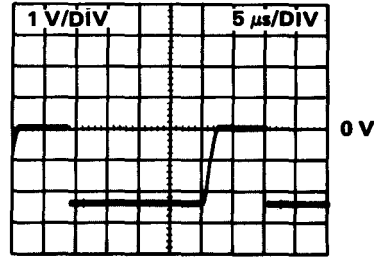

8

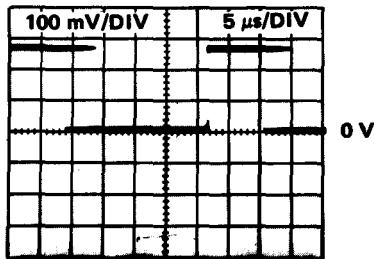

11

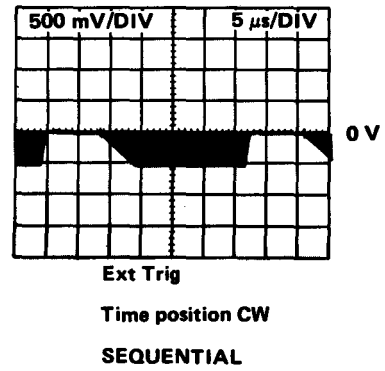

9

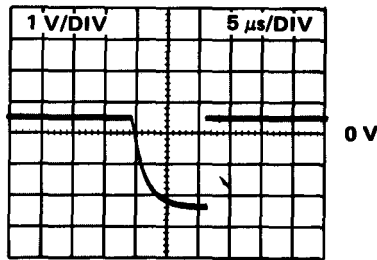

12

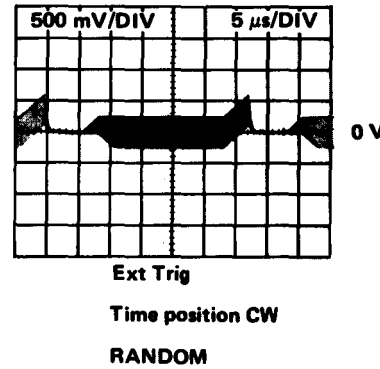

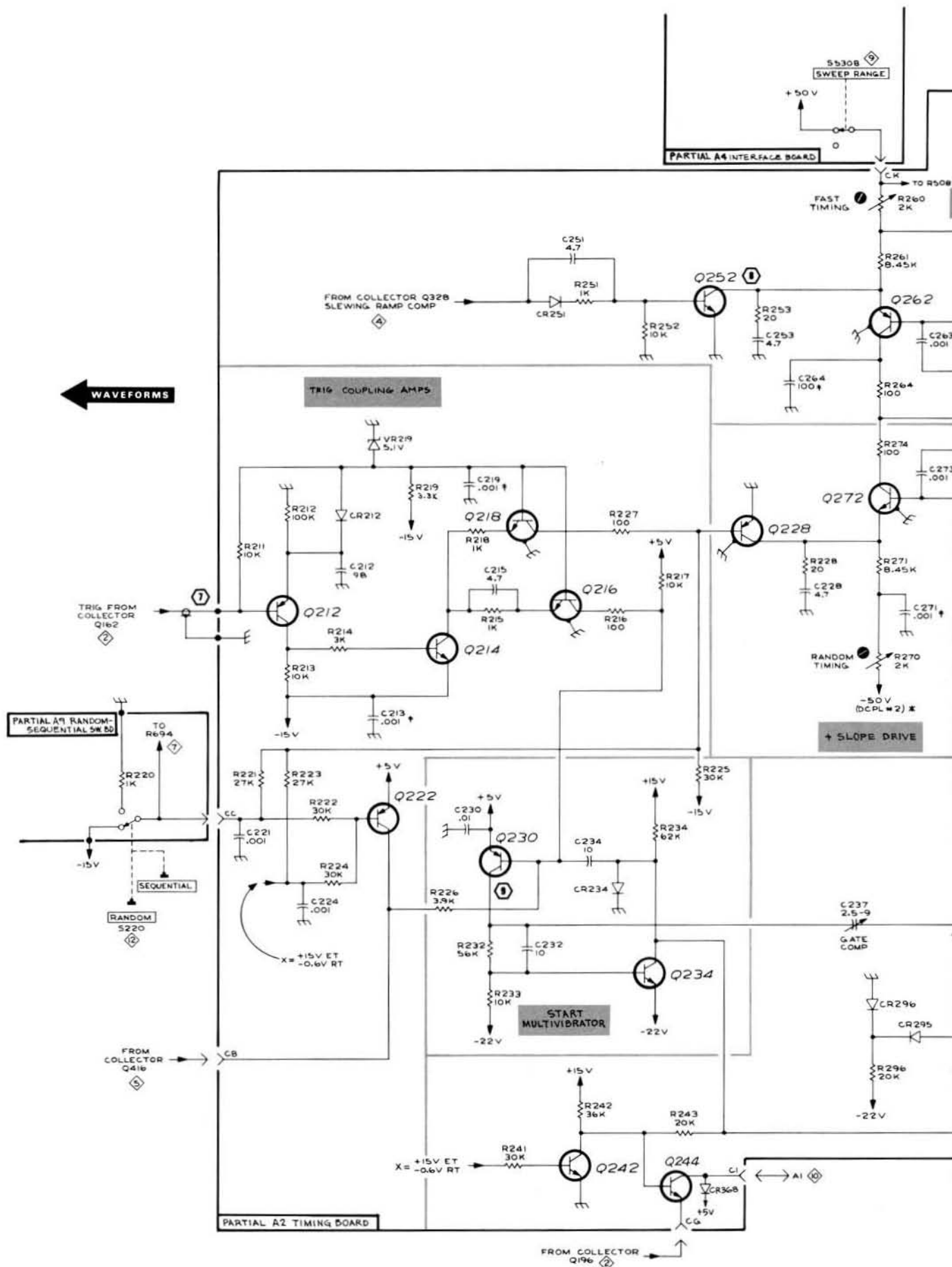

7T11A SAMPLING SWEEP UNIT

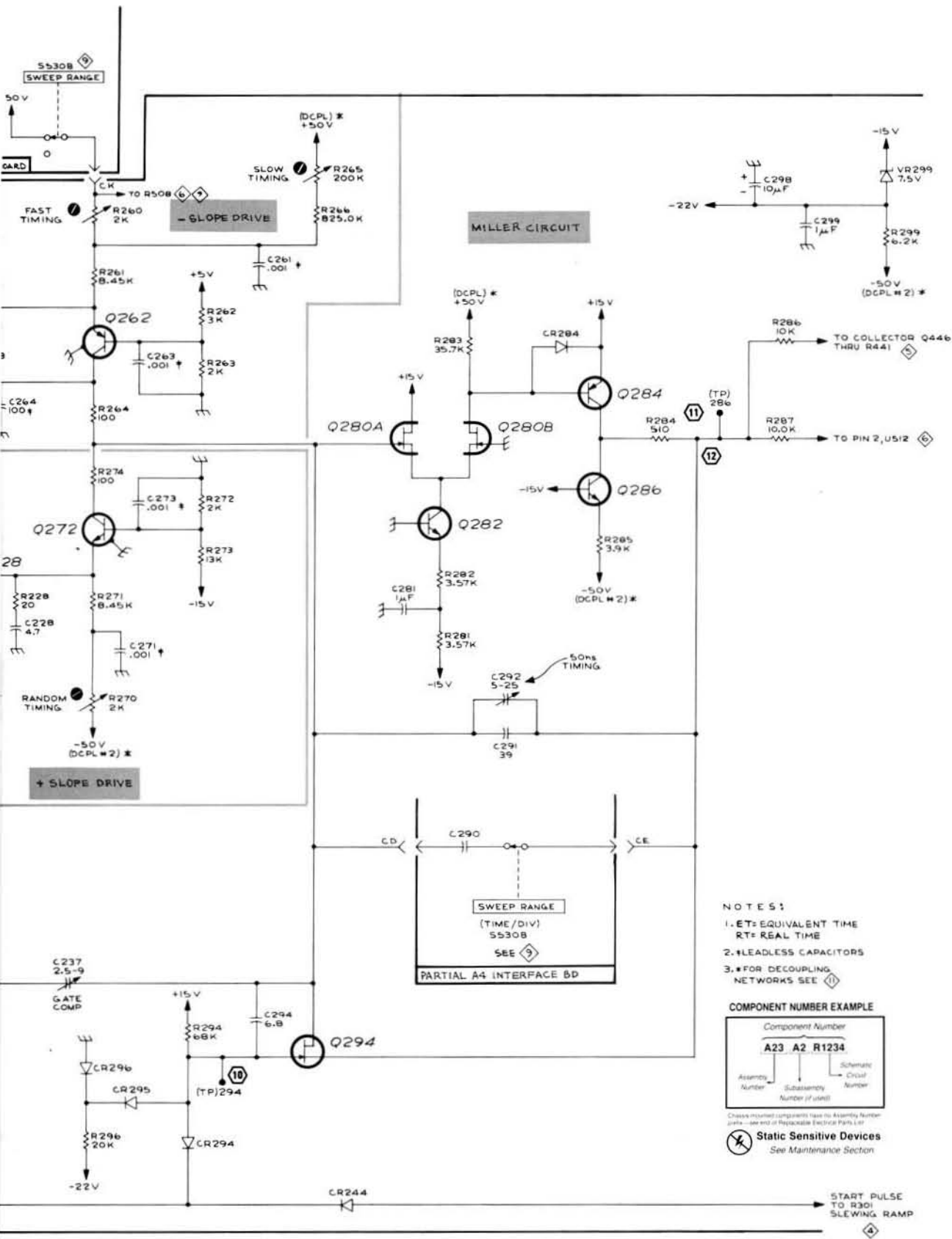

- NOTES:
1. ET= EQUIVALENT TIME  
RT= REAL TIME
  2. †LEADLESS CAPACITORS
  3. \*FOR DECOUPLING NETWORKS SEE (11)

COMPONENT NUMBER EXAMPLE

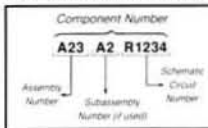

Check mounted components type to Assembly Number  
pins—see end of Replaceable Electrical Parts List

Static Sensitive Devices  
See Maintenance Section

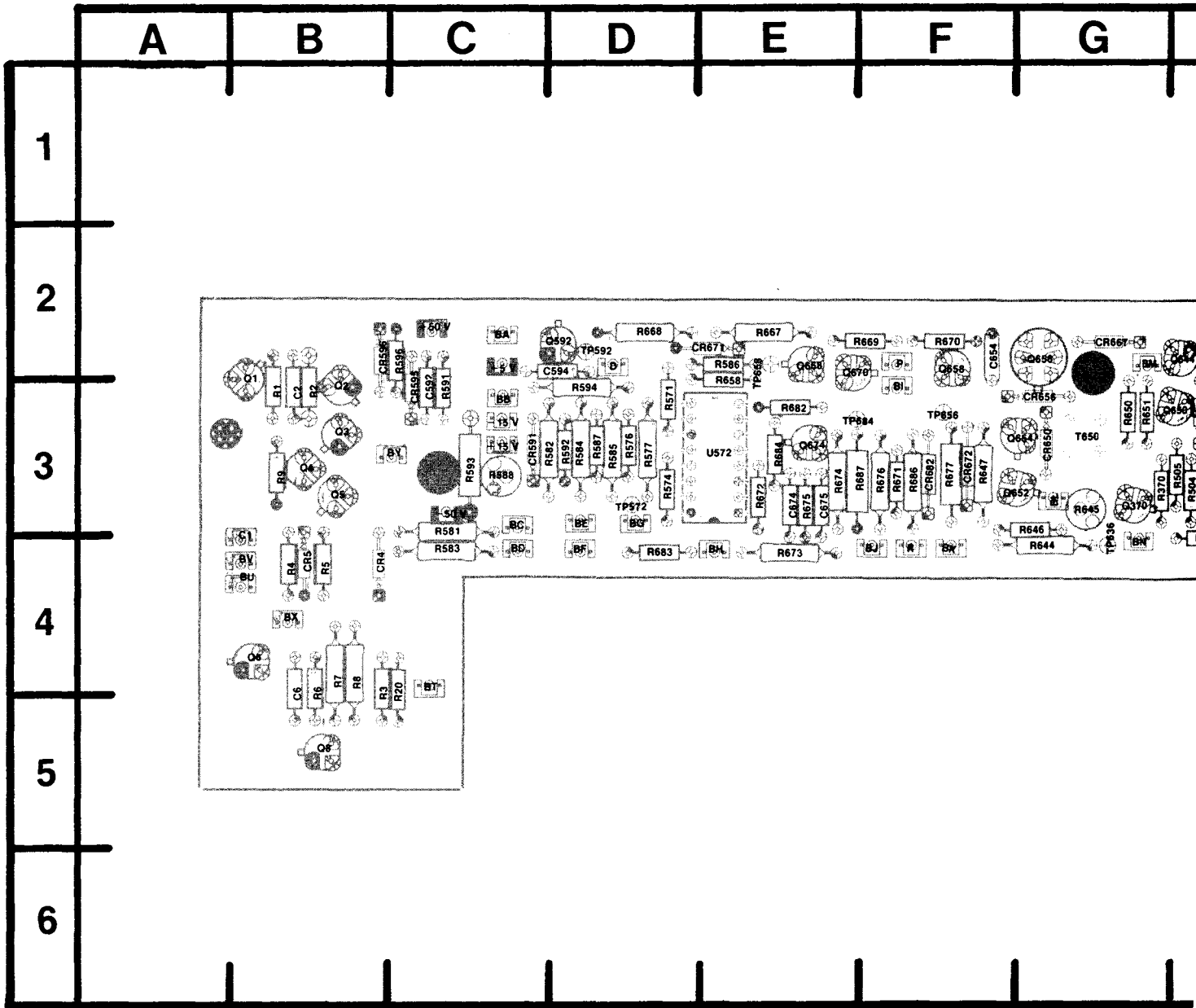

COMPONENT NUMBER EXAMPLE

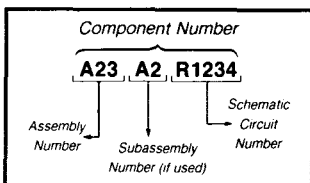

Chassis-mounted components have no Assembly Number prefix—see end of Replaceable Electrical Parts List

**Static Sensitive Devices**  
See Maintenance Section

Figure 8-5. A1—Logic circuit board board assembly

G

H

J

K

L

M

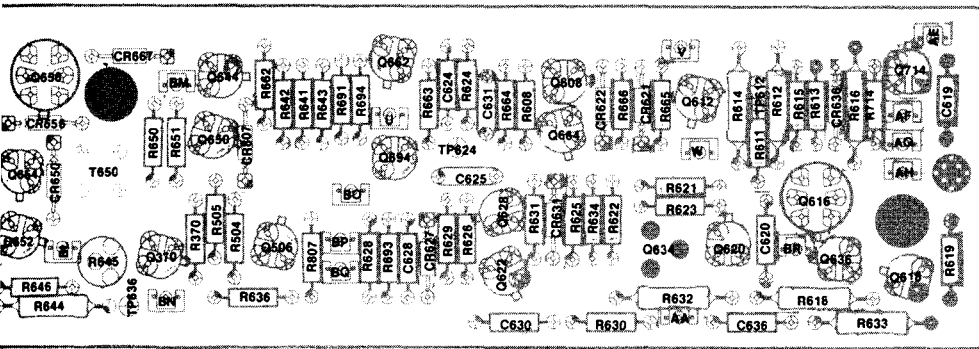

6176-122

A1 LOGIC

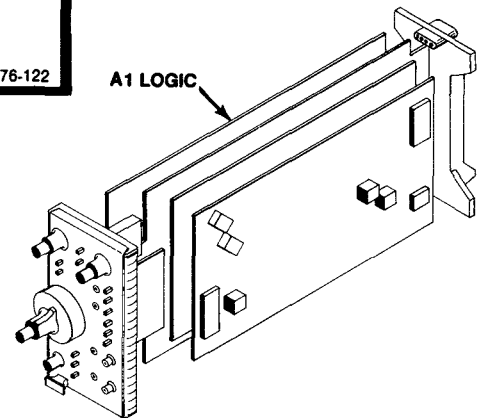

it board board assembly.

CIRCUIT NUMBER	GRID COORD.	CIRCUIT NUMBER	GRID COORD.	CIRCUIT NUMBER	GRID COORD.	CIRCUIT NUMBER	GRID COORD.
-15 V	C3	CR667	G2	R583	C4	R691	H3
-50 V	C3	CR671	E2	R584	D3	R693	H3
+15 V	C3	CR672	F3	R585	D3	R694	H3
+5 V	C2	CR682	F3	R586	E2	R714	L3
+50 V	C2	CR807	H3	R587	D3	R807	H3
				R588	C3		
AA	K4	D	D2	R591	C3	T650	G3
AE	L2			R592	D3		
AF	L3	P	F2	R593	C3	TP572	D3
AG	L3			R594	D3	TP592	D2
		Q1	B2	R596	C2	TP612	K3
BA	C2	Q2	B3	R608	J3	TP624	J3
BB	C3	Q3	B3	R611	K3	TP636	G4
BC	C3	Q4	B3	R612	K3	TP656	F3
BD	C4	Q5	B3	R613	L3	TP658	E3
BE	D3	Q6	B4	R614	K3	TP684	E3
BF	D4	Q8	B5	R615	L3		
BG	D3	Q370	G3	R616	L3	U572	E3
BH	E4	Q506	H3	R618	L4	U	H3
BI	F3	Q592	D2	R619	L3		
BJ	F4	Q608	J2	R621	K3	V	K2
BK	F4	Q612	K3	R622	K3		
BL	G3	Q616	L3	R623	K3	W	K3
BM	G2	Q618	L3	R624	J2		
BN	G4	Q620	K3	R625	J3		
BO	H3	Q622	J3	R626	J3		
BP	H3	Q628	J3	R628	H3		
BQ	H3	Q634	K3	R629	J3		
BR	L3	Q636	L3	R630	K4		
BT	C4	Q644	H2	R631	J3		
BU	B4	Q650	G3	R632	K4		
BV	B4	Q652	F3	R633	L4		
BX	B4	Q652	G3	R634	K3		
BY	B3	Q654	F2	R636	H4		
		Q656	G2	R641	H3		
C1	B4	Q658	F2	R642	H3		
C2	B3	Q662	H2	R644	G4		
C6	B5	Q664	J3	R645	G3		
C592	C3	Q668	E2	R646	G3		
C594	D2	Q670	E2	R647	F3		
C619	L3	Q674	E3	R650	G3		
C620	K3	Q694	H3	R651	G3		
C624	J2	Q714	L2	R658	E3		
C625	J3			R662	H2		
C628	J3	R	F4	R663	J3		
C630	J4	R1	B3	R664	J3		
C631	J3	R2	B3	R665	K3		
C636	K4	R3	B5	R666	K3		
C654	F2	R4	B4	R667	E2		
C674	E2	R5	B4	R668	D2		
C675	E3	R6	B5	R669	F2		
		R7	B4	R670	F2		
CR4	B4	R8	B4	R671	F3		
CR5	B4	R9	B3	R672	E3		
CR591	C3	R20	C4	R673	E4		
CR595	C3	R370	G3	R674	E3		
CR596	B2	R504	H3	R675	E3		
CR621	K3	R505	H3	R676	F3		
CR622	K3	R571	D3	R677	F3		
CR627	J3	R574	D3	R682	E3		
CR631	J3	R576	D3	R683	D4		
CR636	L3	R577	D3	R684	E3		
CR650	G3	R581	C3	R686	F3		
CR656	G3	R582	C3	R687	E3		



13

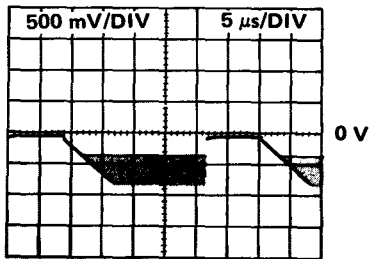

15

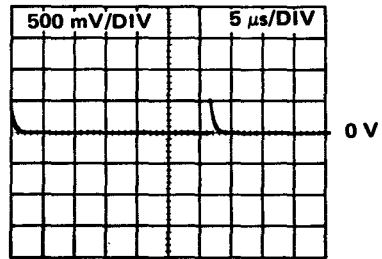

1000 Ω resistor between pins 17 & 18 of J641

14

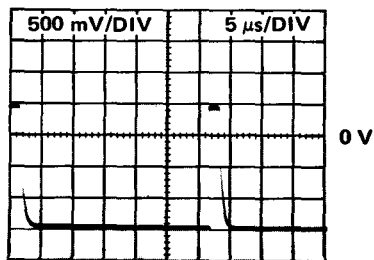

16

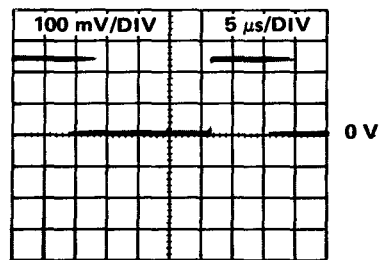

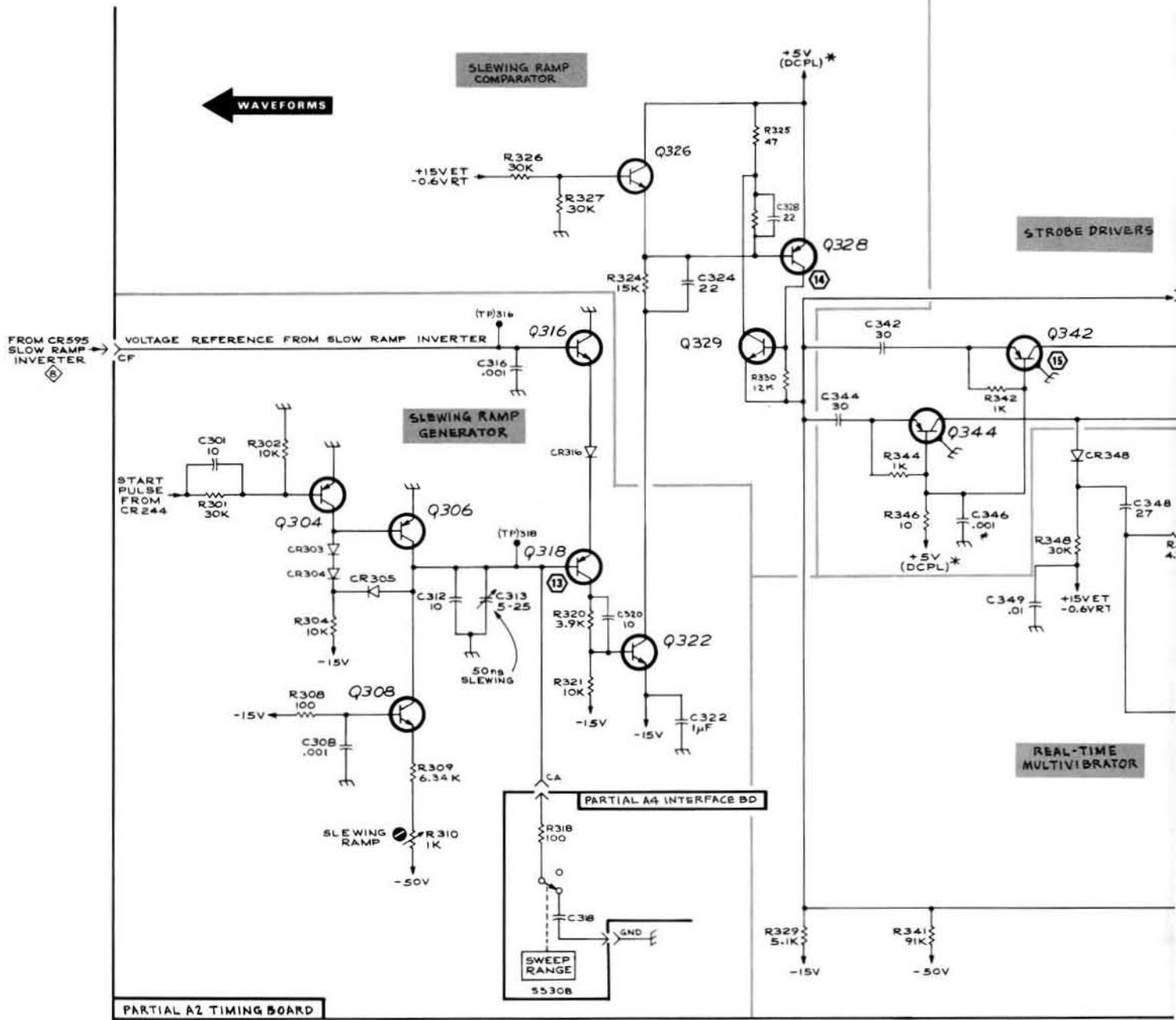

- NOTES:
- 1. \* LEADLESS CAPACITOR
  - 2. \* FOR DECOUPLING NETWORKS SEE (1)

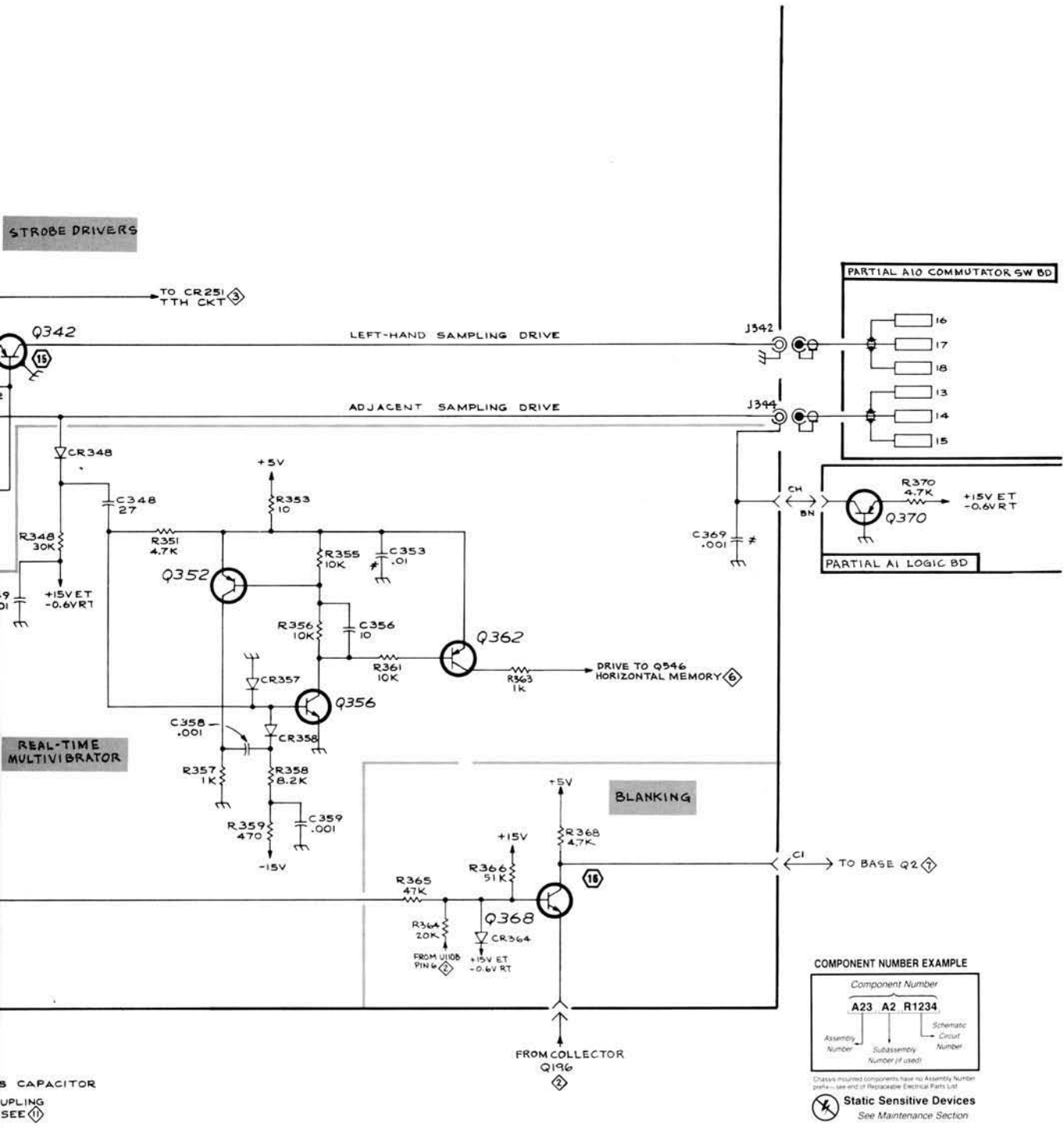

**COMPONENT NUMBER EXAMPLE**

Component Number		
A23	A2	R1234
Assembly Number	Subassembly Number (if used)	Schematic Circuit Number

Chassis-mounted components have no Assembly Number prefix—see end of Replaceable Electrical Parts List

**Static Sensitive Devices**  
See Maintenance Section

SLEWING RAMP & RT MULTIVIBRATOR 4

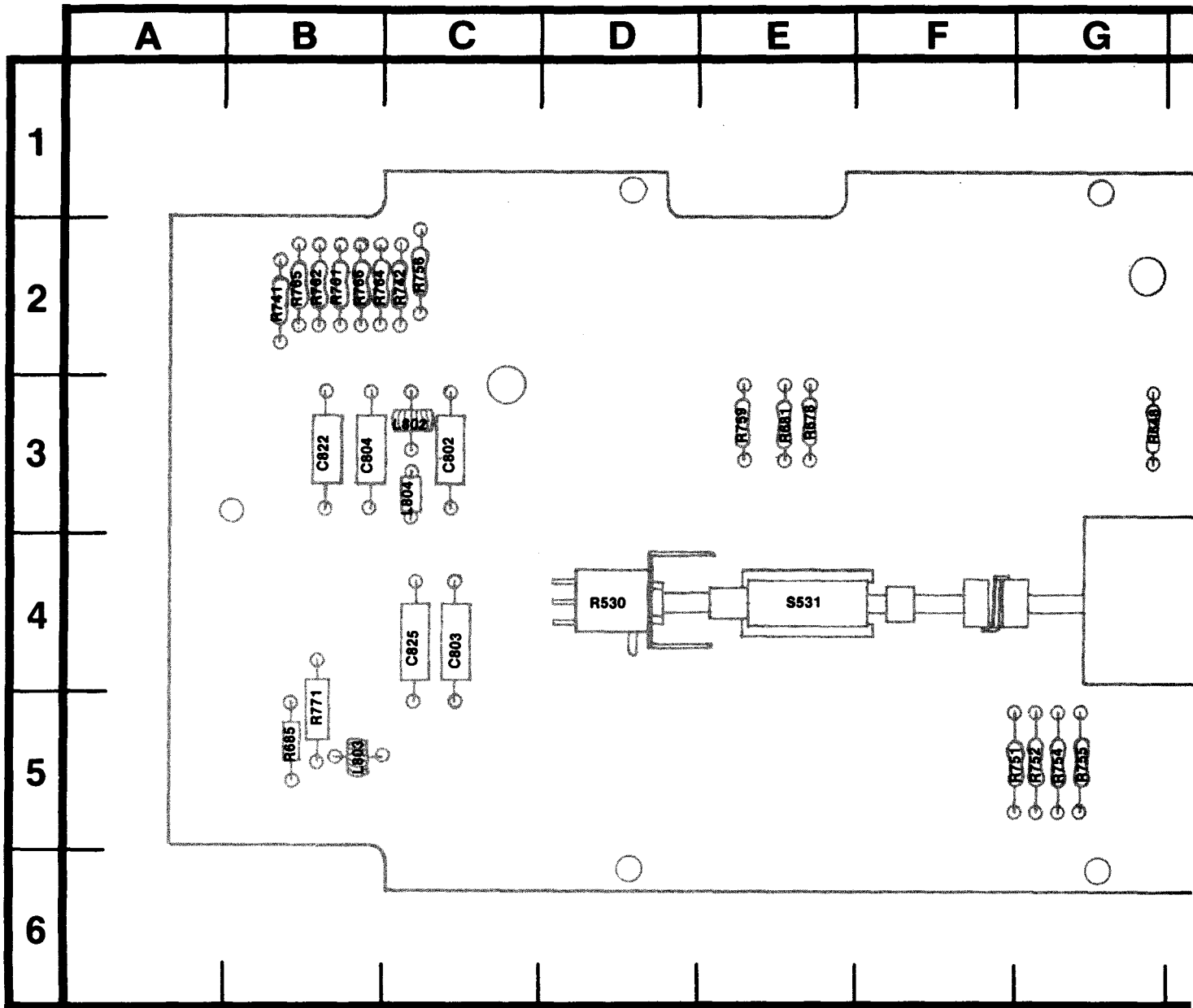
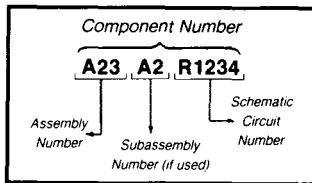

Figure 8-6. A4-Interface circuit

**COMPONENT NUMBER EXAMPLE**



Chassis-mounted components have no Assembly Number prefix—see end of Replaceable Electrical Parts List

 **Static Sensitive Devices**  
See Maintenance Section

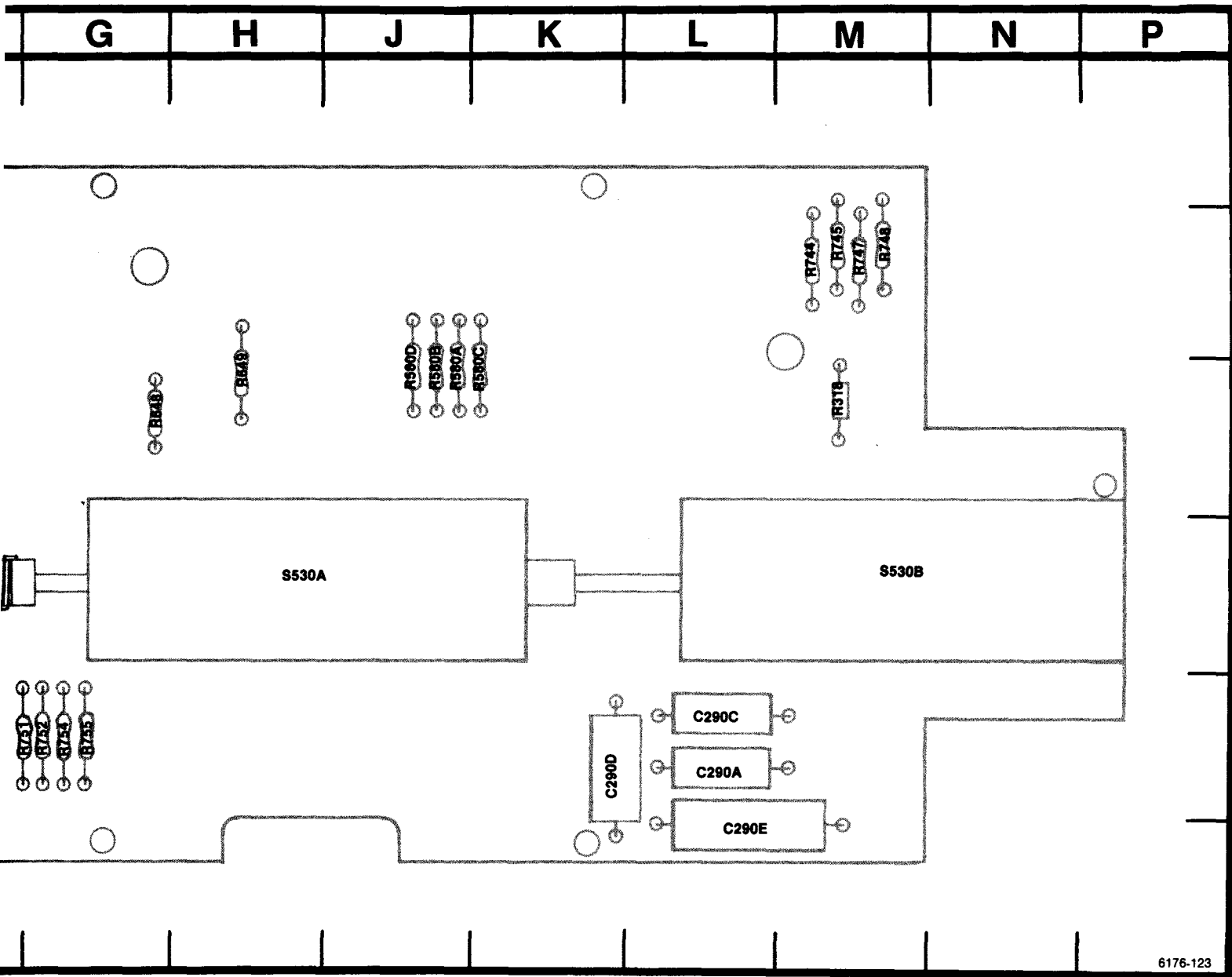

6176-123

8-6. A4-Interface circuit board assembly.

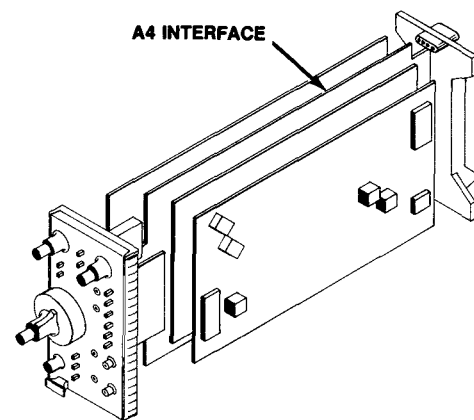

CIRCUIT NUMBER	GRID COORD.	CIRCUIT NUMBER	GRID COORD.
C100A	†	R649	H3
C100B	†	R678	E3
C290A	L5	R681	E3
C290C	L5	R685	B5
C290D	K5	R741	B1
C290E	L6	R742	C1
C318A	†	R744	M2
C318B	†	R745	M2
C318C	†	R747	M2
C802	C3	R748	M2
C803	C4	R751	G5
C804	B3	R752	G5
C822	B3	R754	G5
C825	C4	R755	G5
		R756	C1
L802	C3	R759	E3
L803	B5	R761	B1
L804	C3	R762	B1
		R764	B1
R318	M3	R765	B1
R530	D4	R766	B1
R580A	J3	R771	B5
R580B	J3		
R580C	K3	S530A	H4
R580D	J3	S530B	M4
R648	G3	S531	E4

† Located on back of board.

17

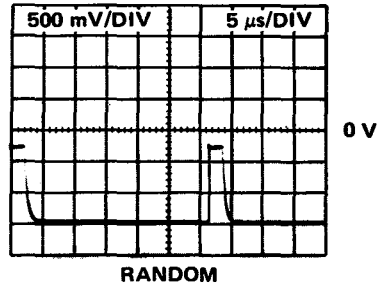
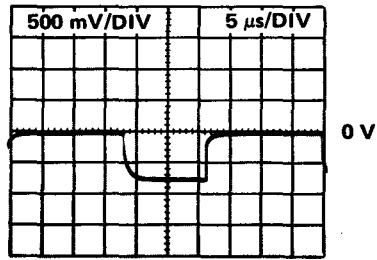

20

18

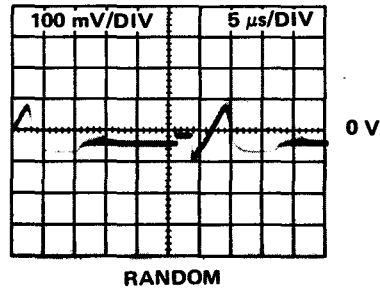
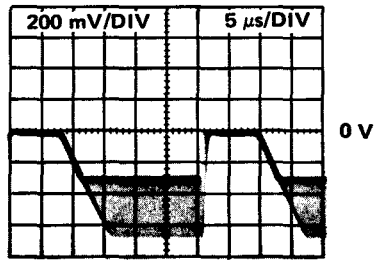

21

19

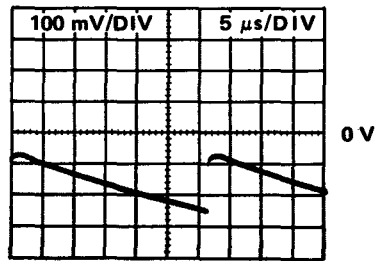
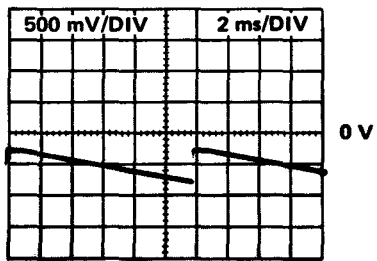

22

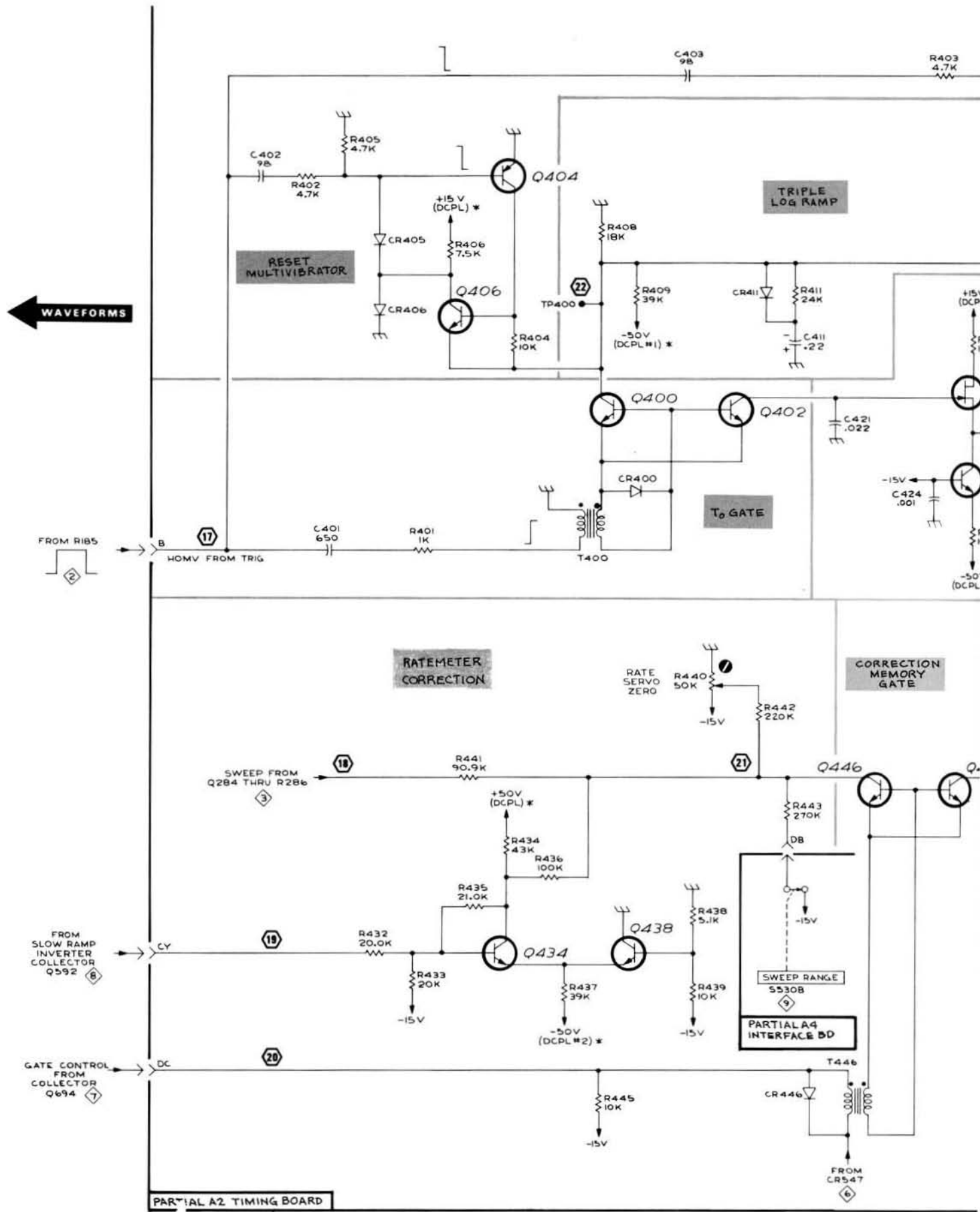

7T11A SAMPLING SWEEP UNIT



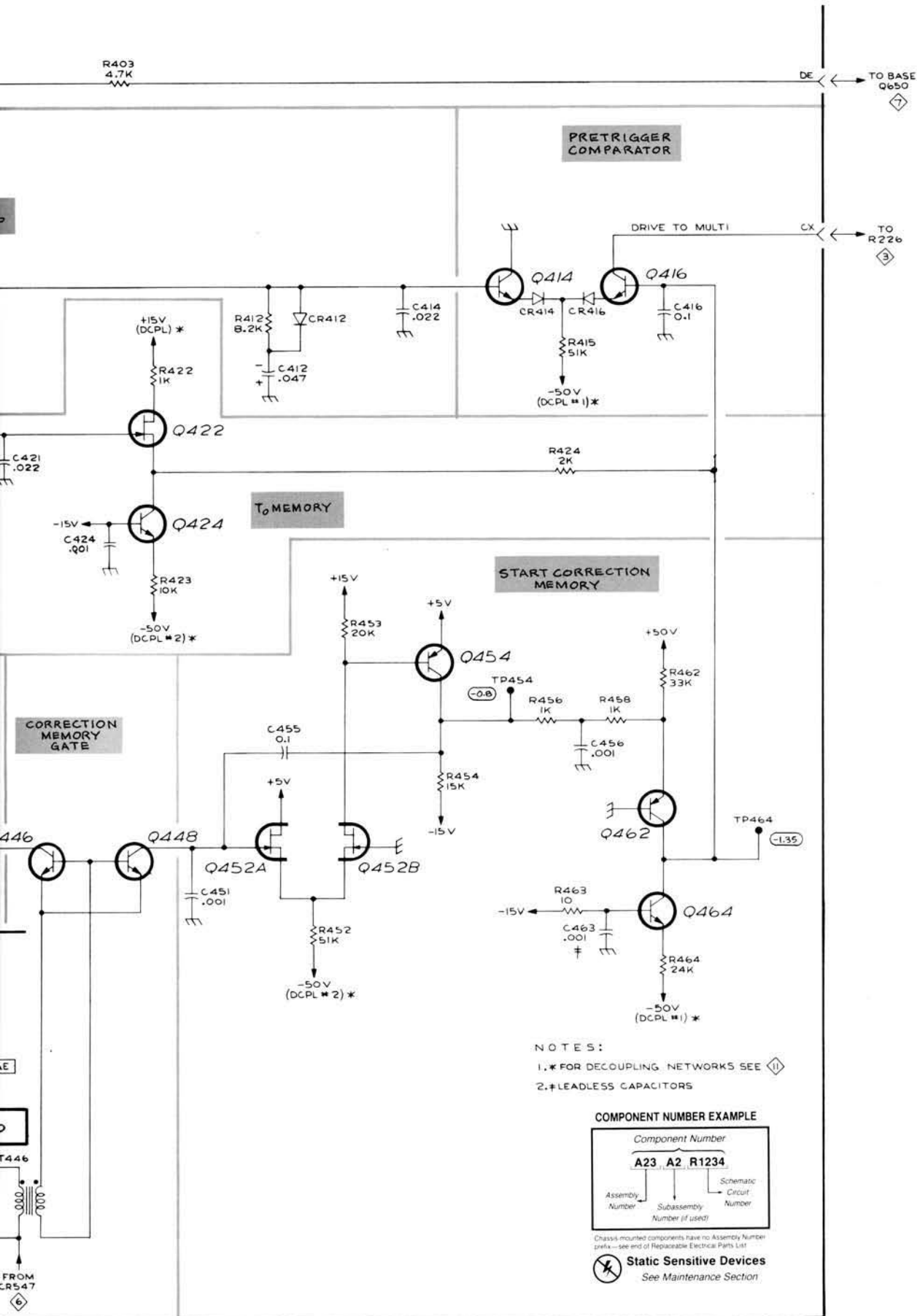

RATEMETER 5

- NOTES:
1. \* FOR DECOUPLING NETWORKS SEE (11)
  2. # LEADLESS CAPACITORS

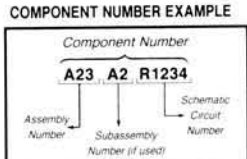

Chassis-mounted components have no Assembly Number prefix—see end of Replaceable Electrical Parts List

**Static Sensitive Devices**  
See Maintenance Section

23

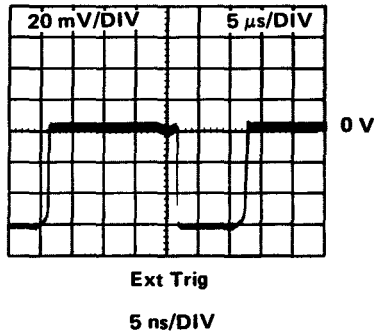

26

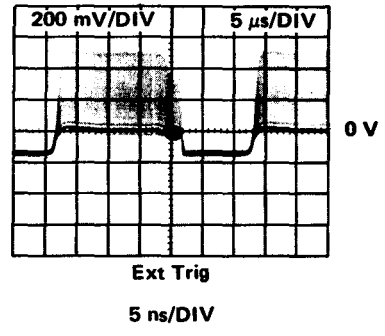

24

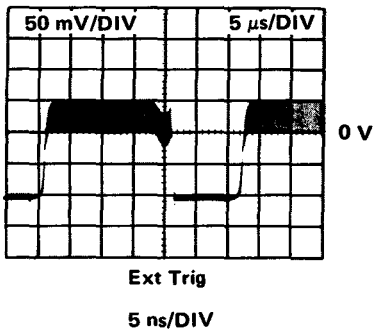

27

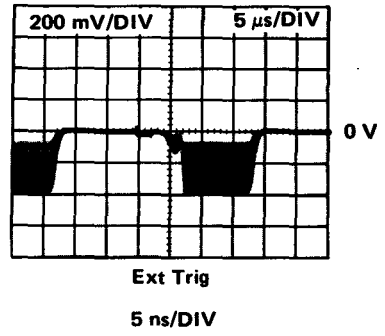

25

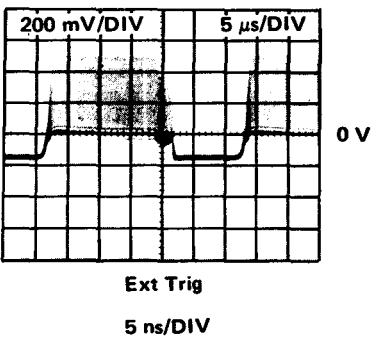

28

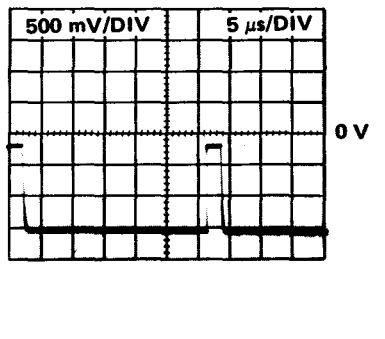

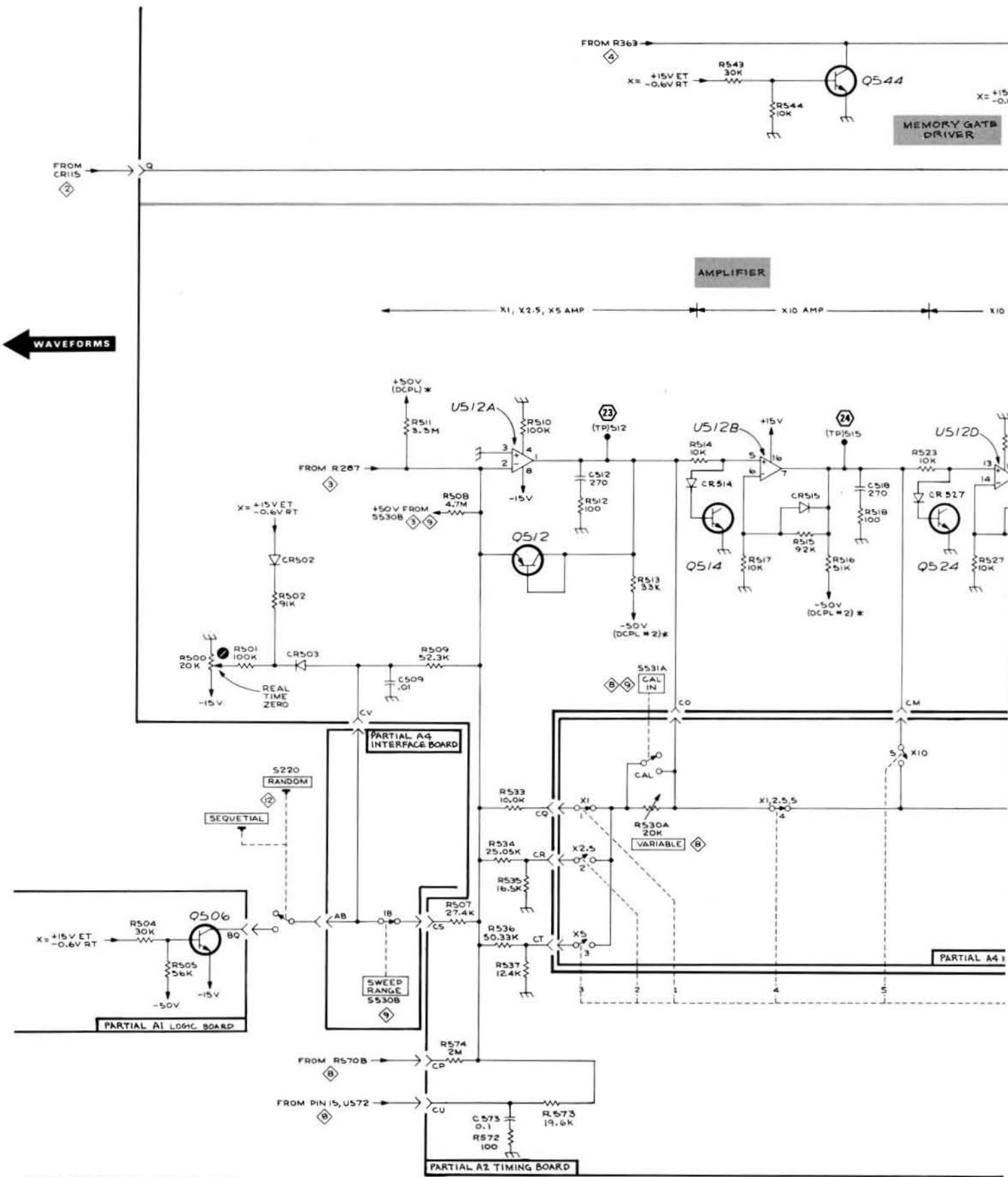

7T11A SAMPLING SWEEP UNIT

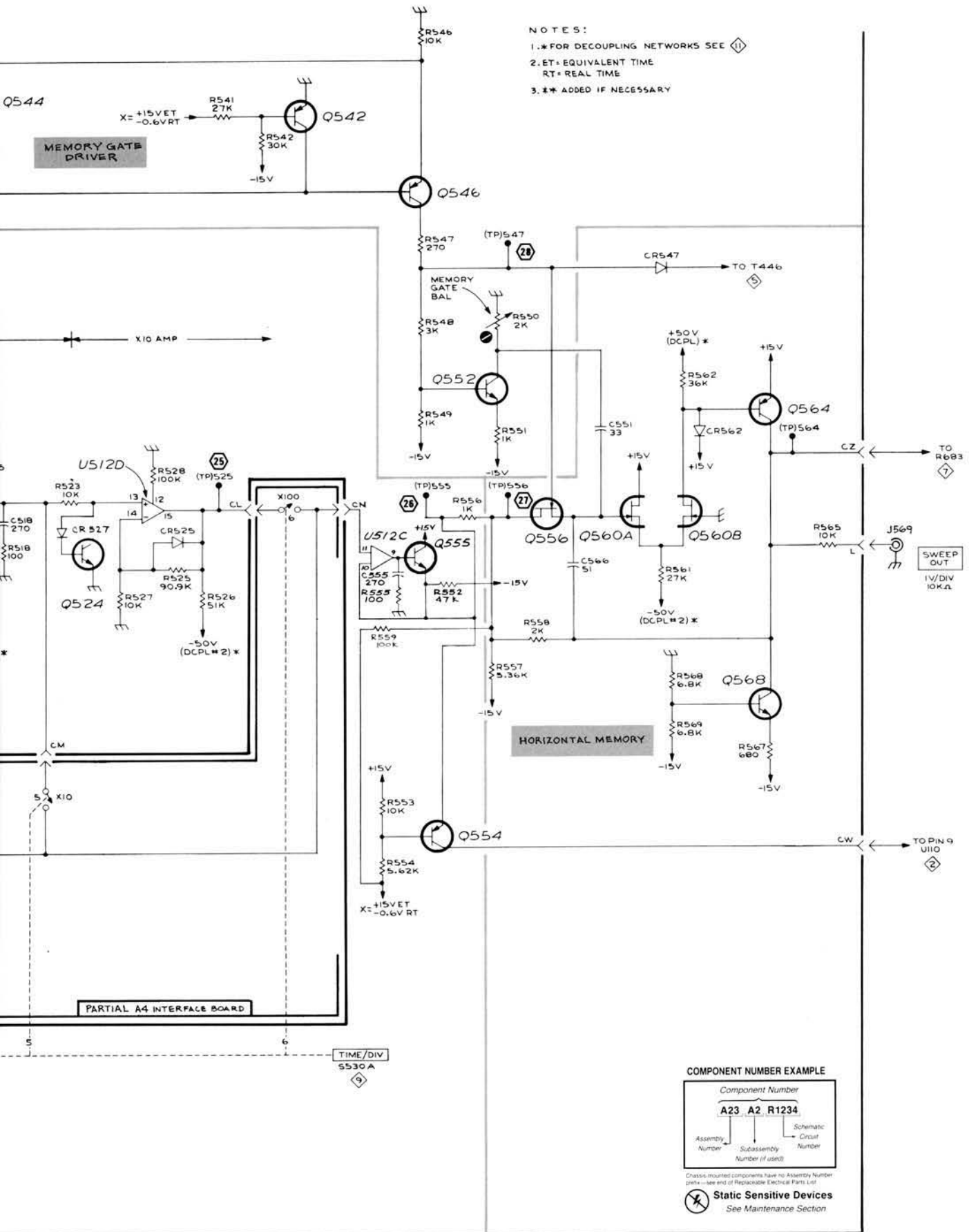

- NOTES:
- \* FOR DECOUPLING NETWORKS SEE ①
  - ET = EQUIVALENT TIME  
RT = REAL TIME
  - \*\* ADDED IF NECESSARY

HORIZONTAL AMPLIFIER

⑥

COMPONENT NUMBER EXAMPLE

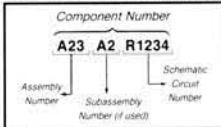

Chassis-mounted components have no Assembly Number prefix - see end of Replaceable Electrical Parts List

⊗ Static Sensitive Devices  
See Maintenance Section

29

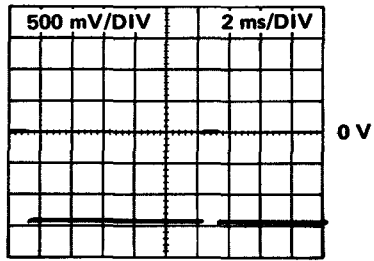

31

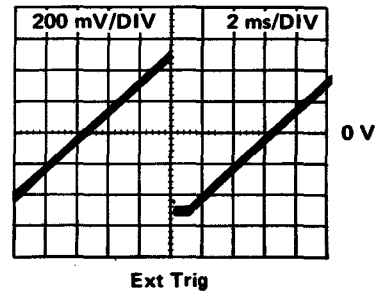

30

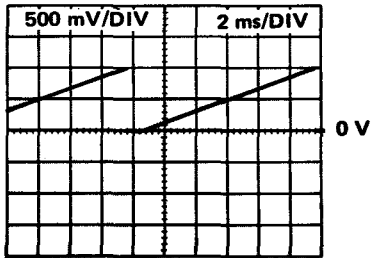

32

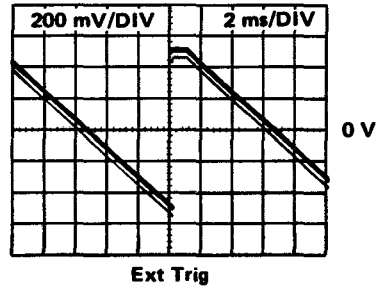

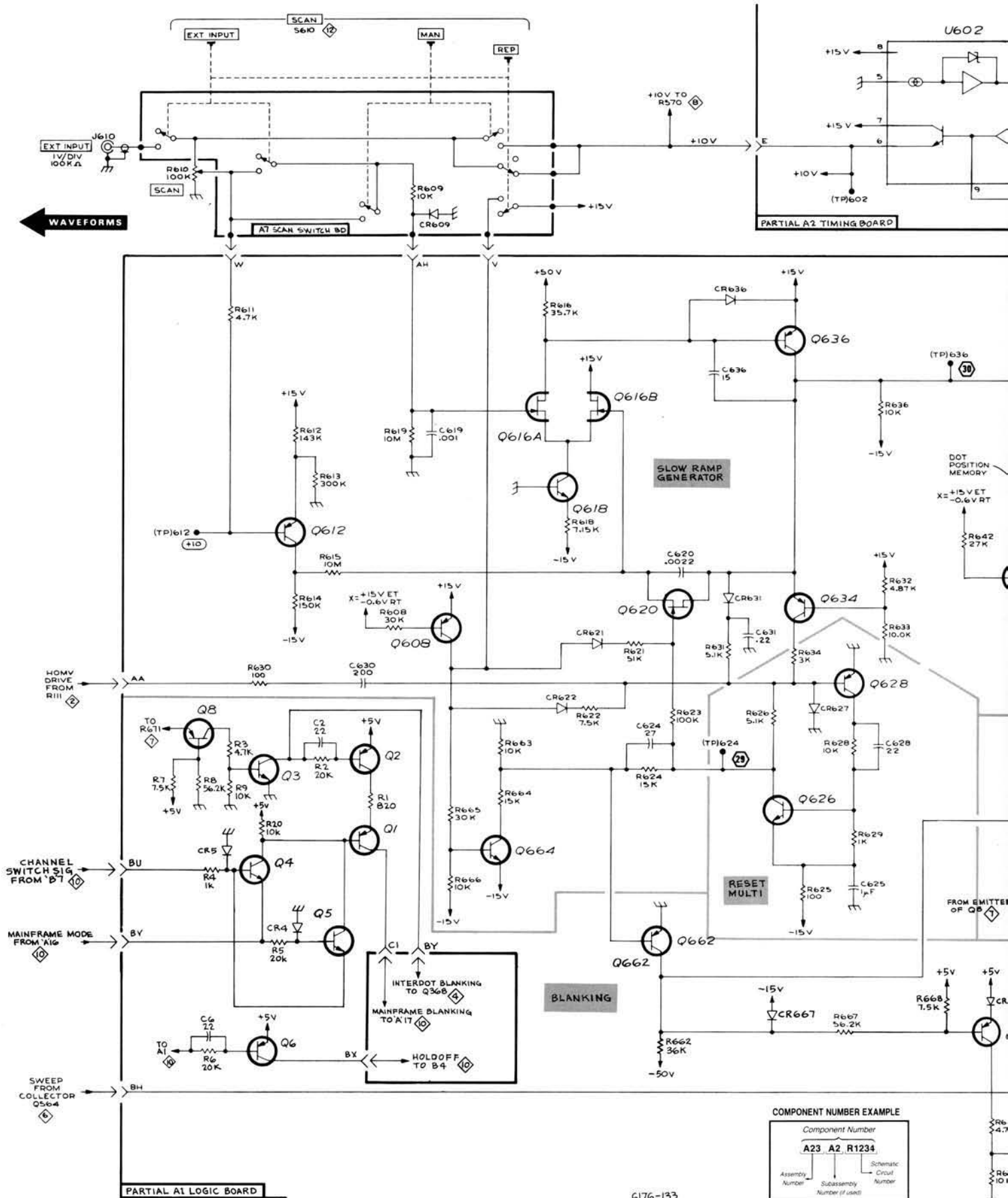

7T11A SAMPLING SWEEP UNIT

6176-133

COMPONENT NUMBER EXAMPLE

Component Number		
A23 A2 R1234		
Assembly Number	Subassembly Number (if used)	Schematic Circuit Number

Class-mounted components have no Assembly Number prefix - see end of Replaceable Electrical Parts List

**Static Sensitive Devices**  
See Maintenance Section

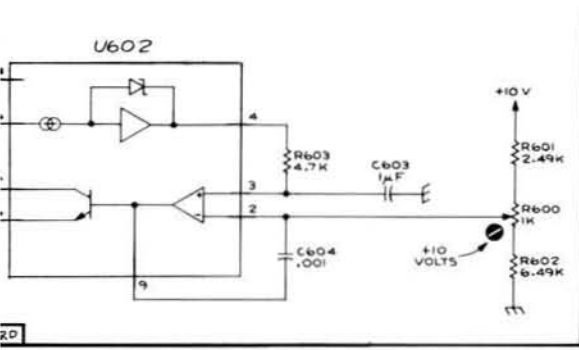

NOTES:  
 1. ET = EQUIVALENT TIME  
 RT = REAL TIME  
 2. U602, PINS 1 & 10 NOT USED

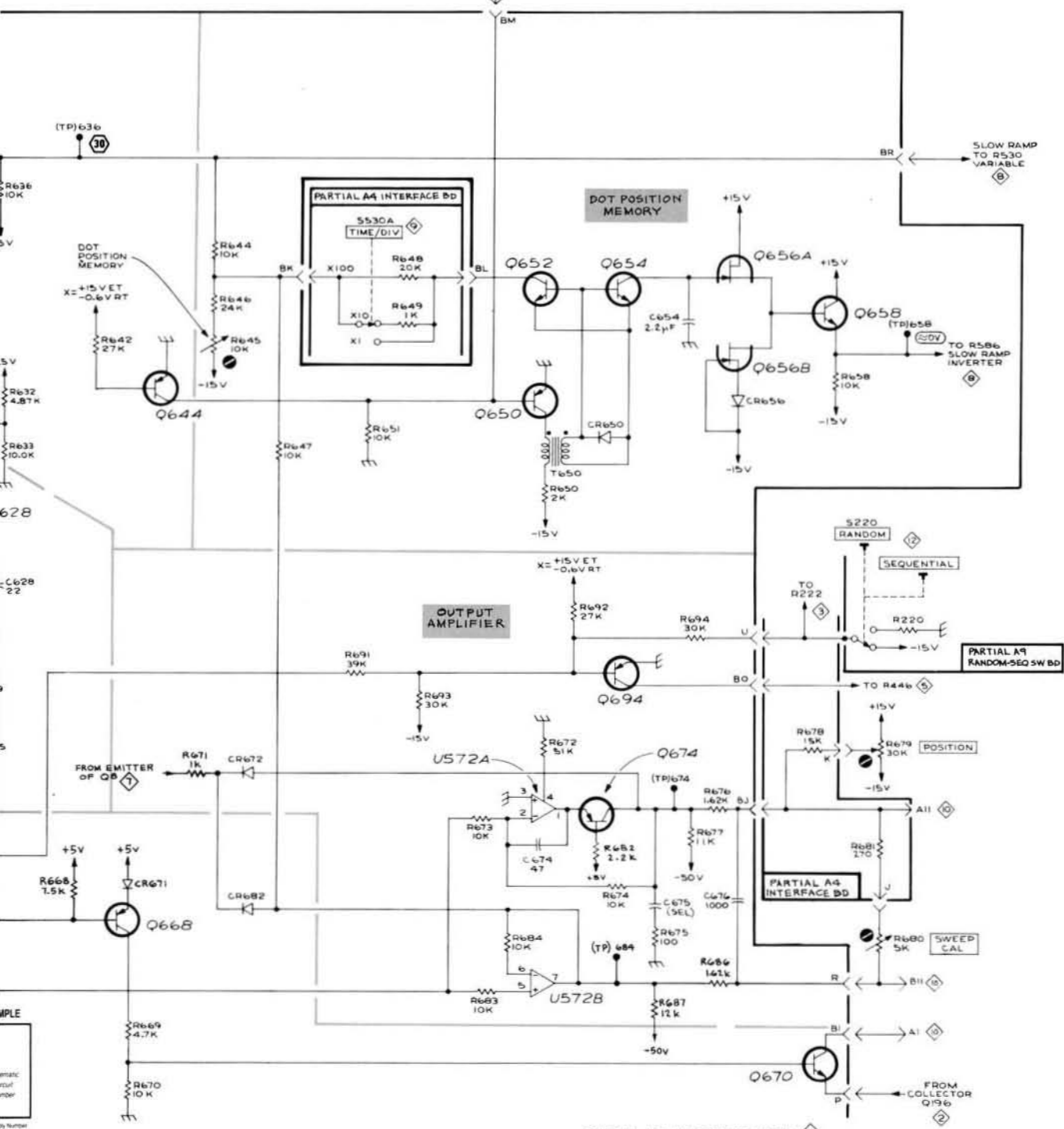

SLOW RAMP GENERATOR & OUTPUT AMPLIFIER

SLOW RAMP GENERATOR & OUTPUT AMPLIFIER

33

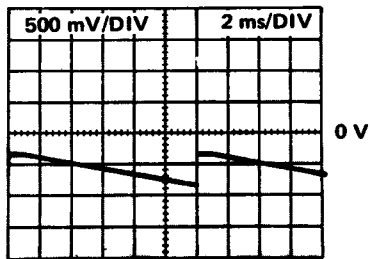



← WAVEFORMS

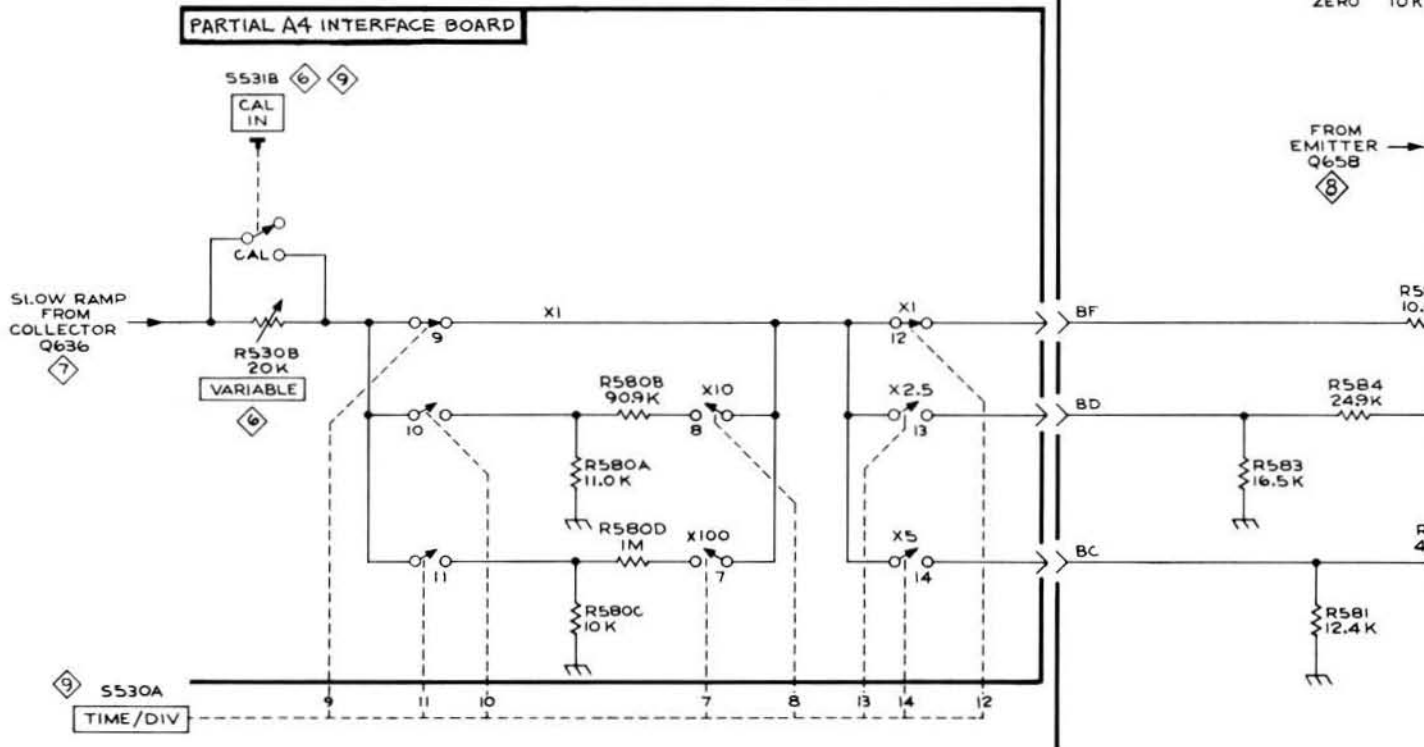
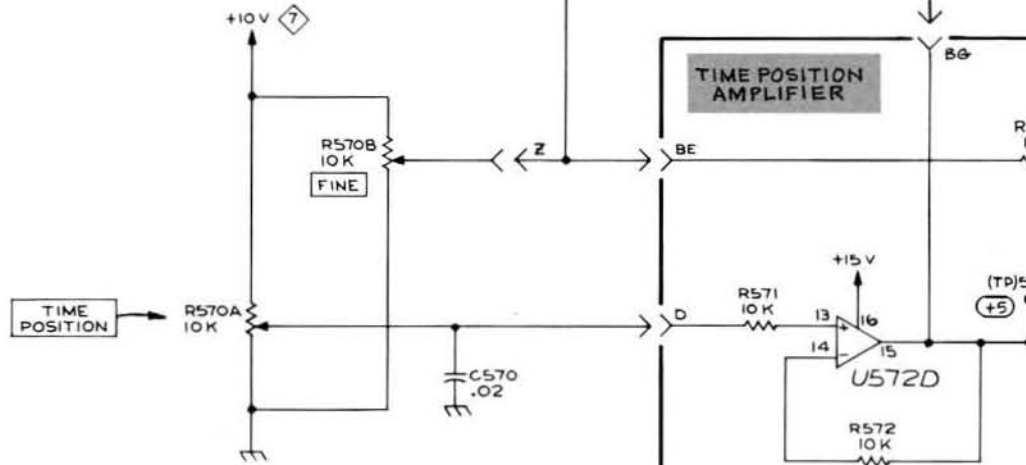

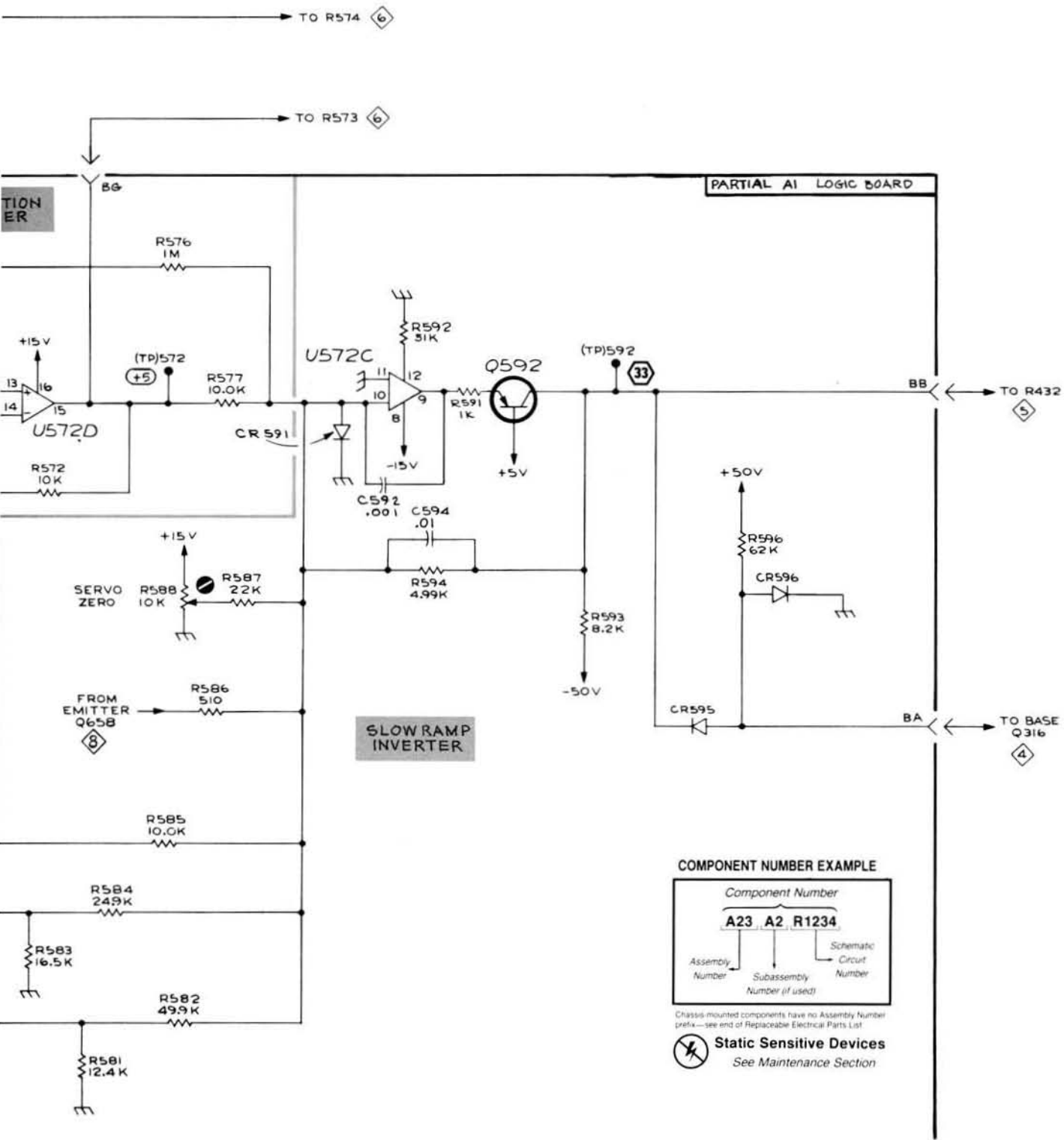

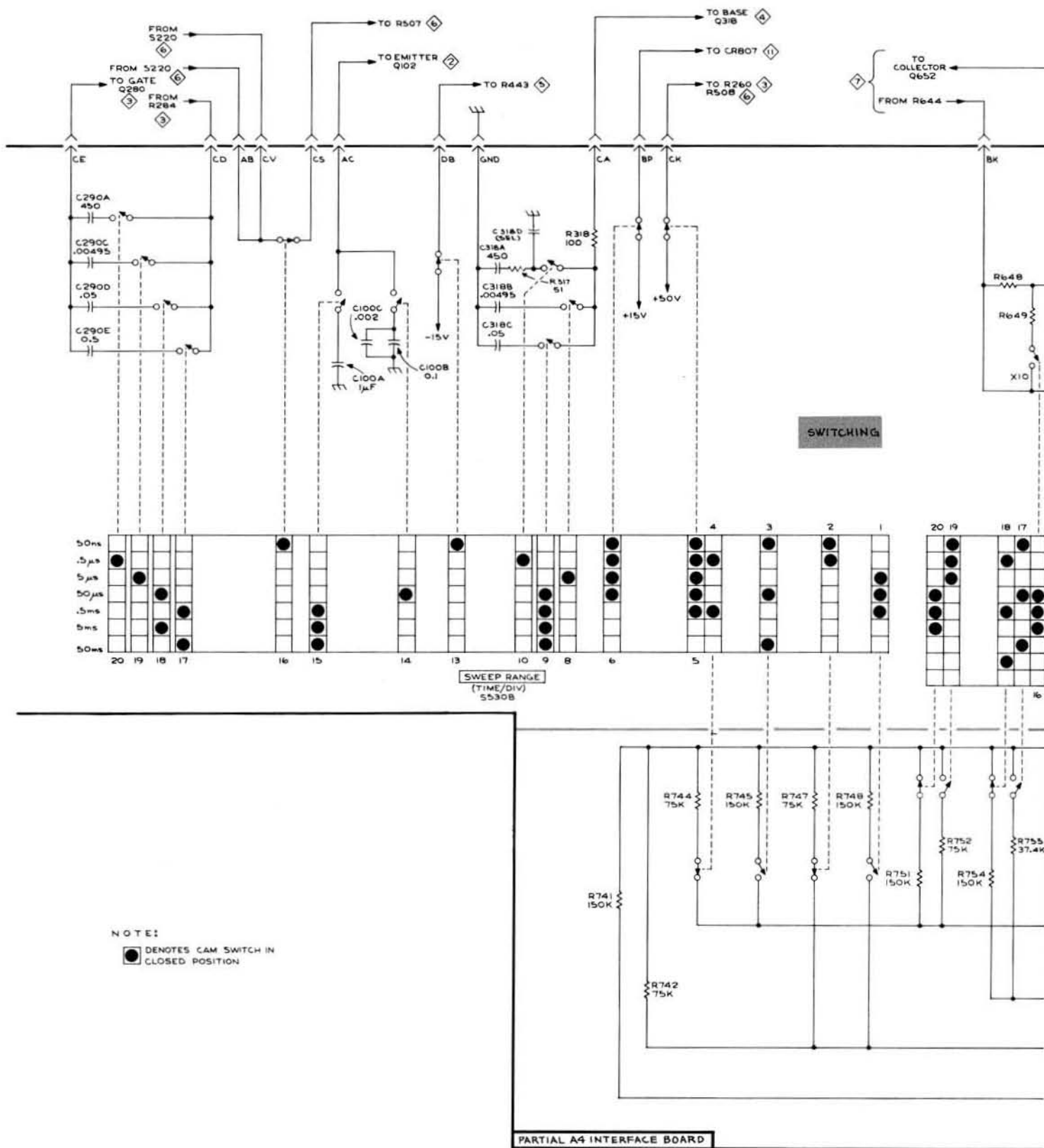

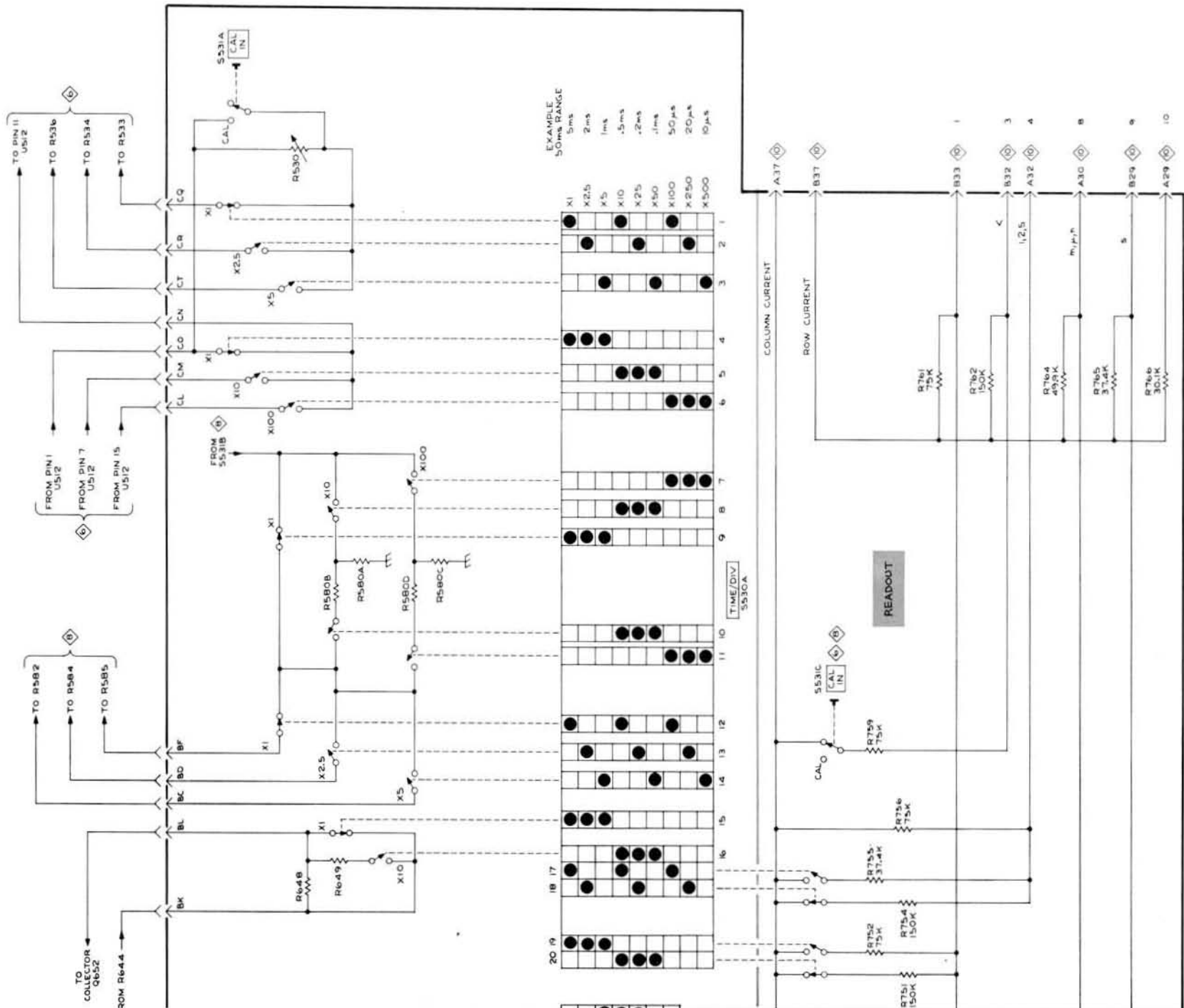

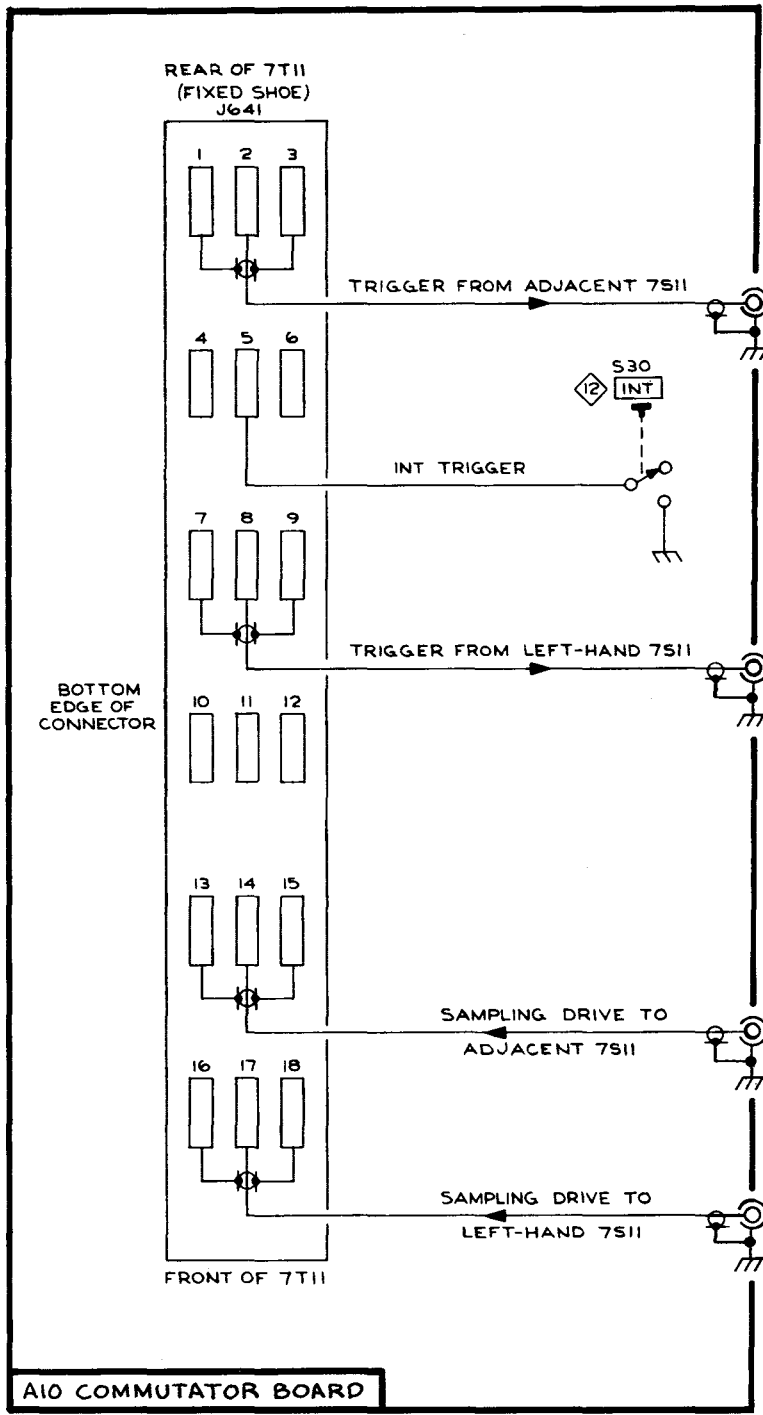

A10 COMMUTATOR BOARD

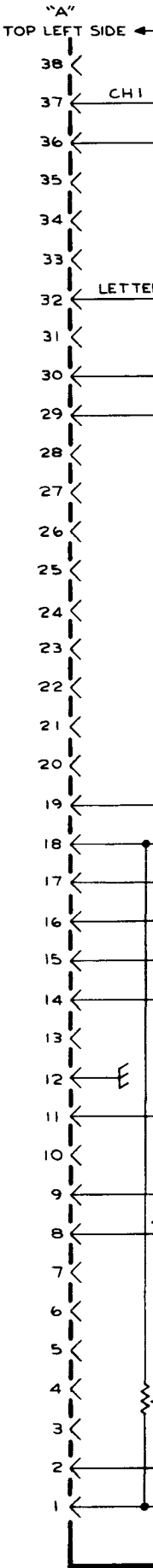

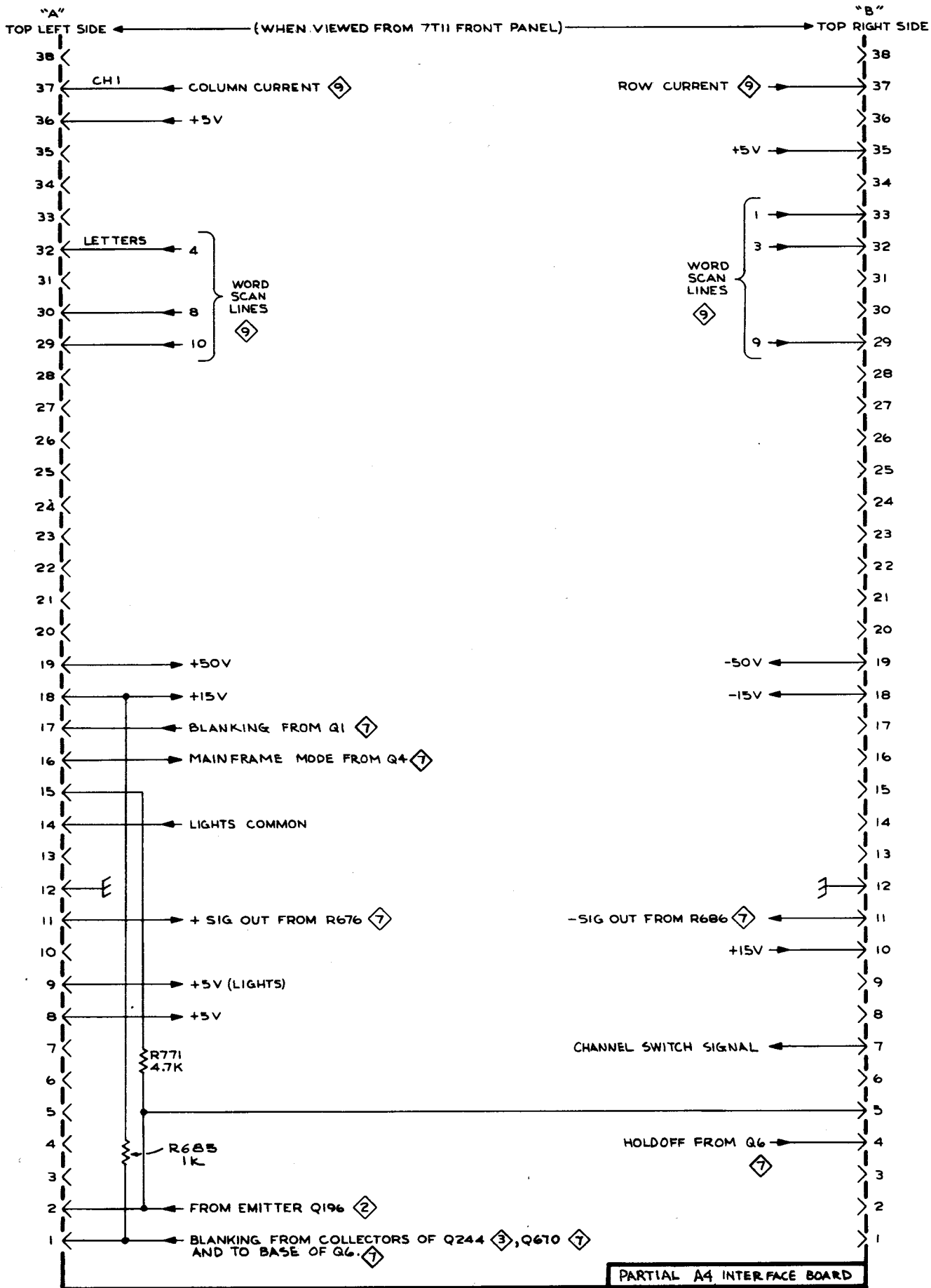

OUTPUT CONNECTORS



OUTPUT CONNECTORS

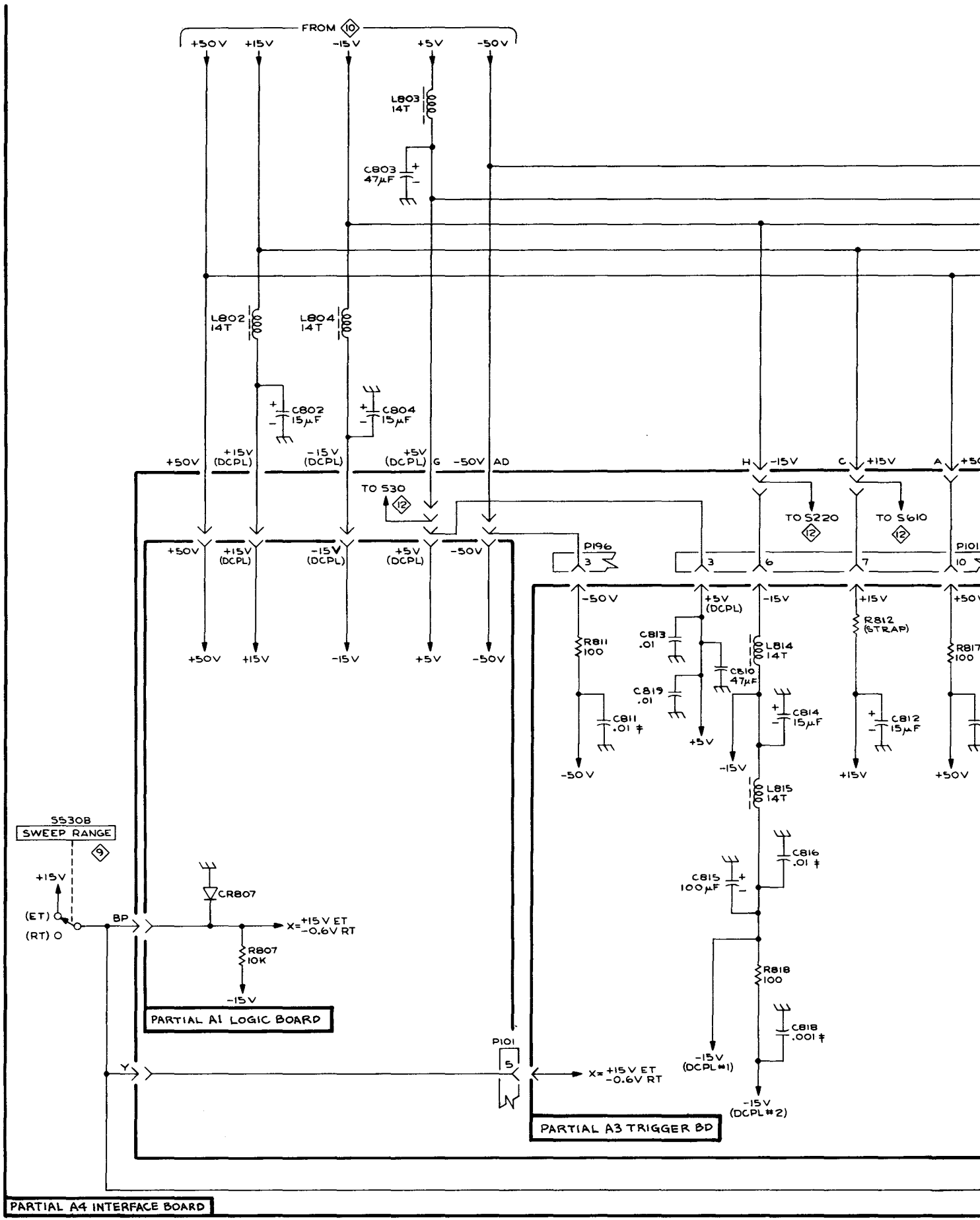

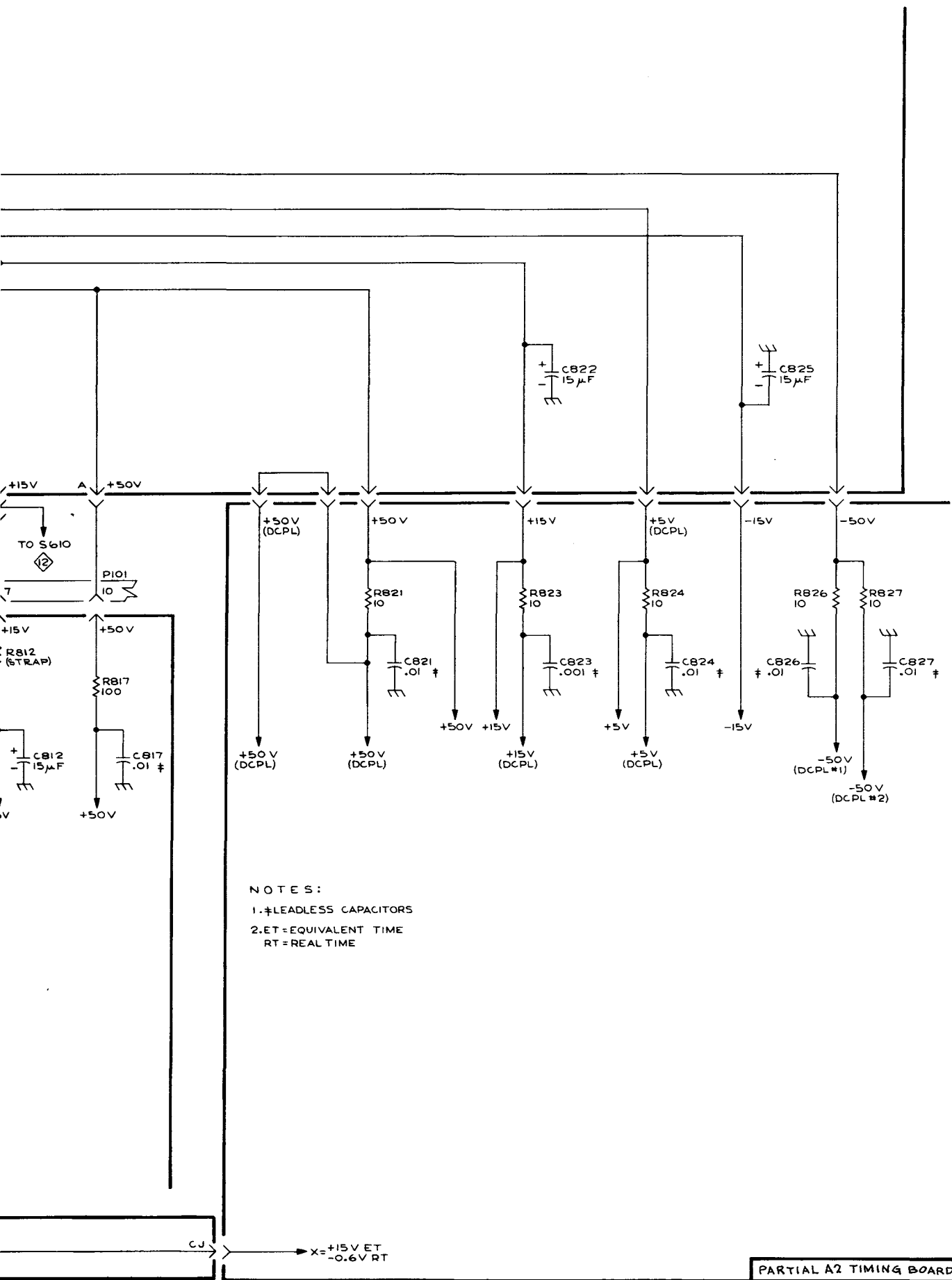

VOLTAGE DISTRIBUTION & DECOUPLING



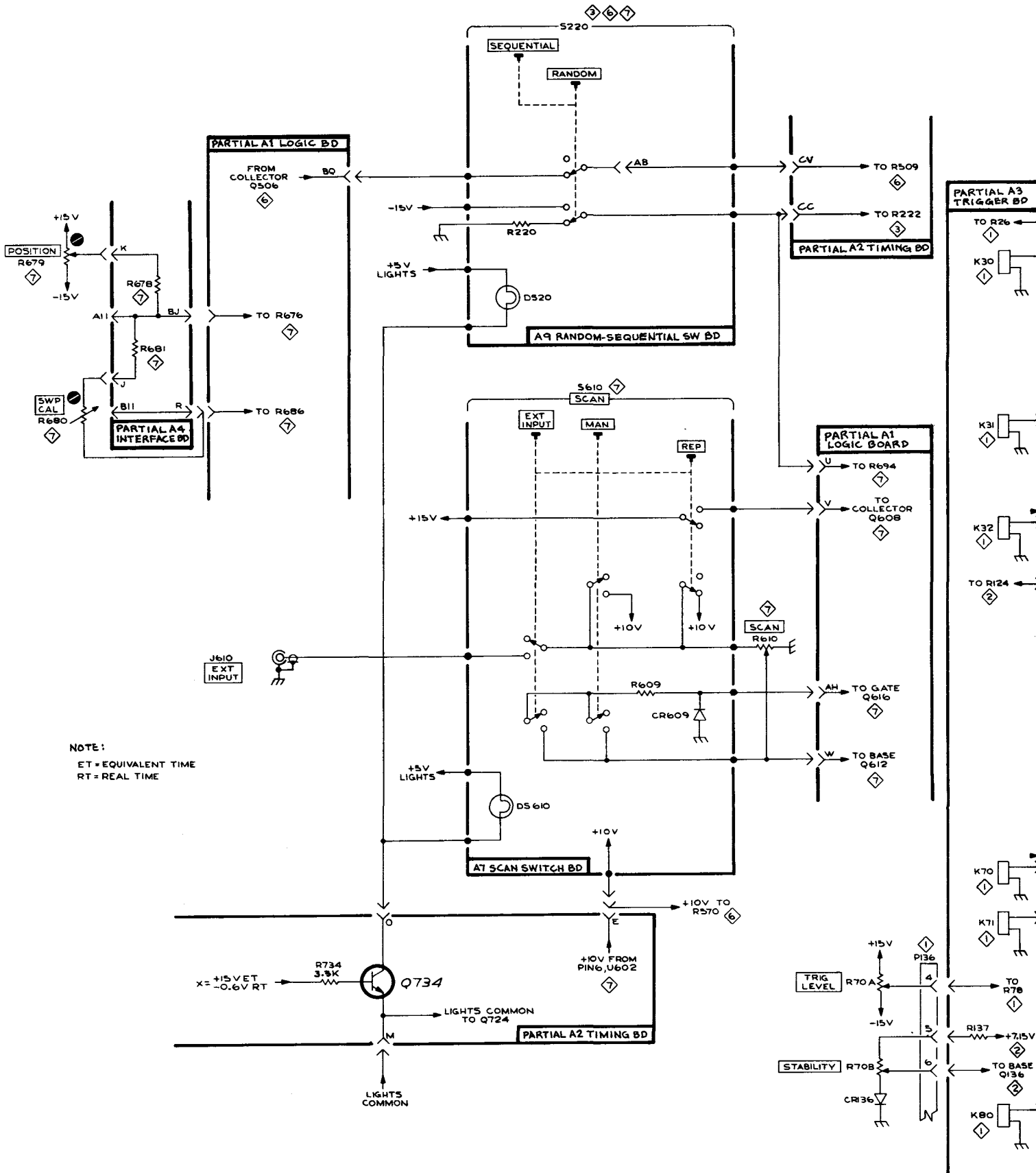

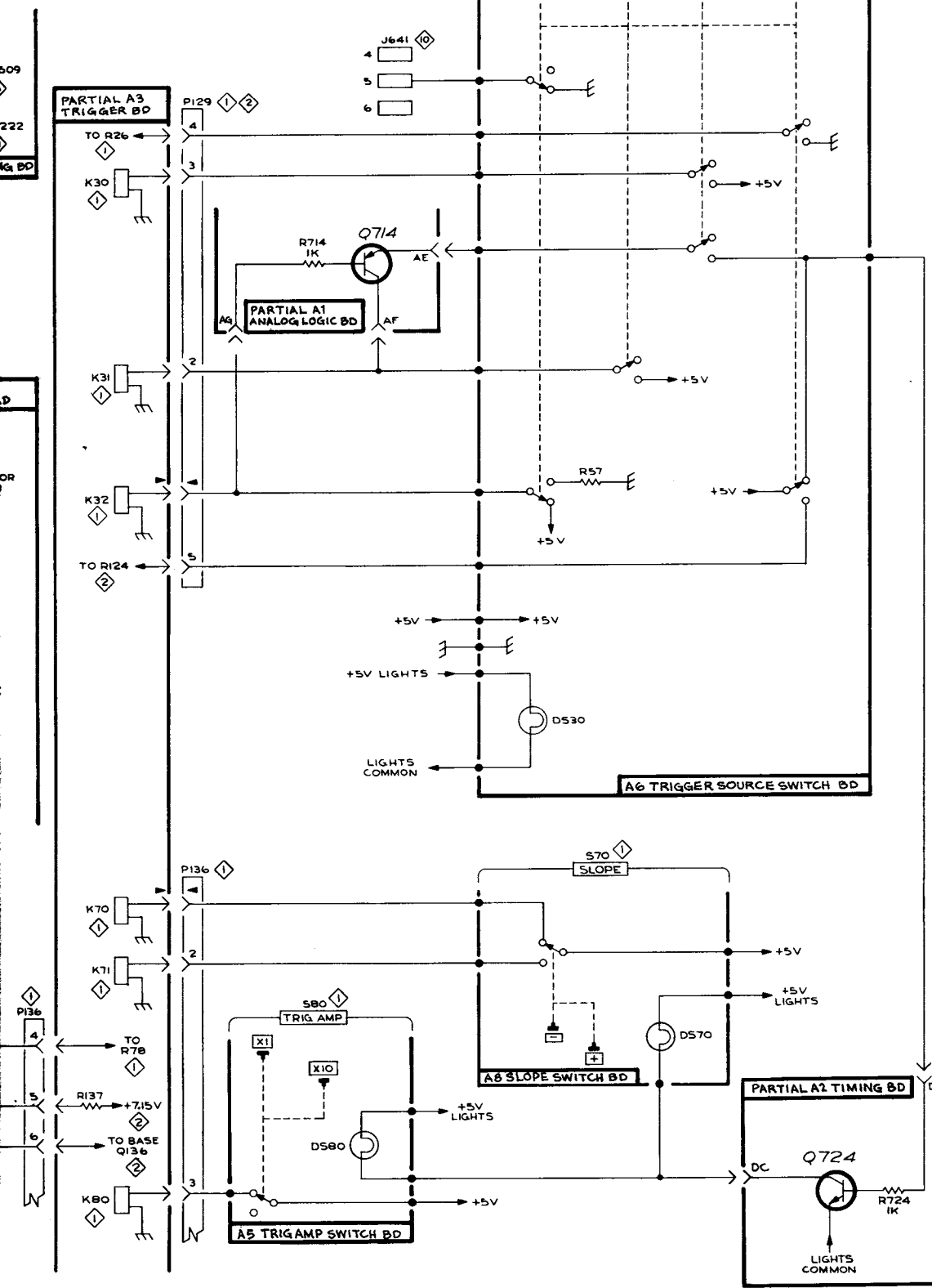

**COMPONENT NUMBER EXAMPLE**

Component Number		
A23, A2, R1234		
Assembly Number	Subassembly Number (if used)	Schematic Circuit Number

Chassis-mounted components have no Assembly Number prefix—see end of Replaceable Electrical Parts List

**Static Sensitive Devices**  
See Maintenance Section

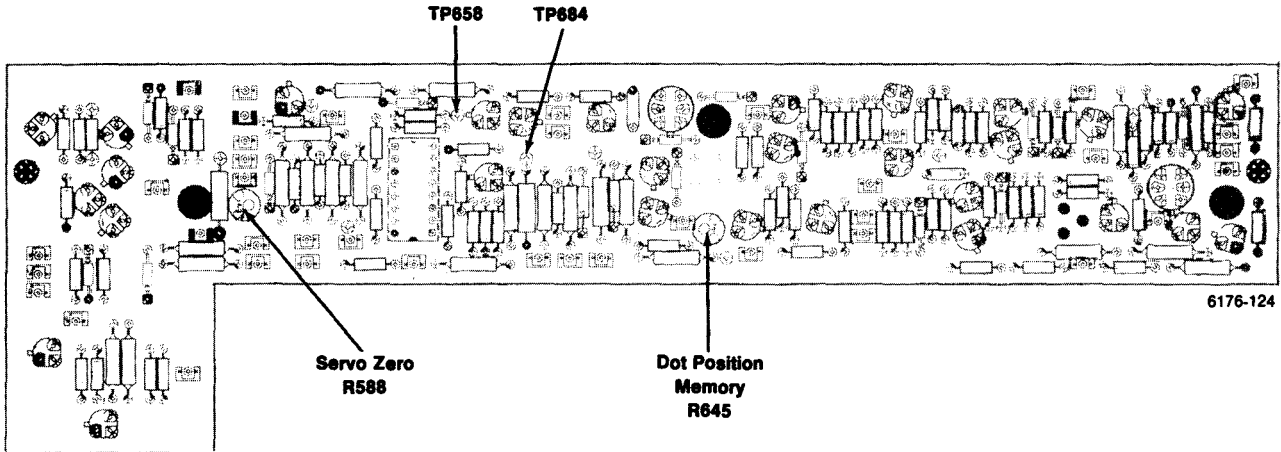

A1

Figure 8-7. Location of Logic adjustments.

A3

1M  
- R

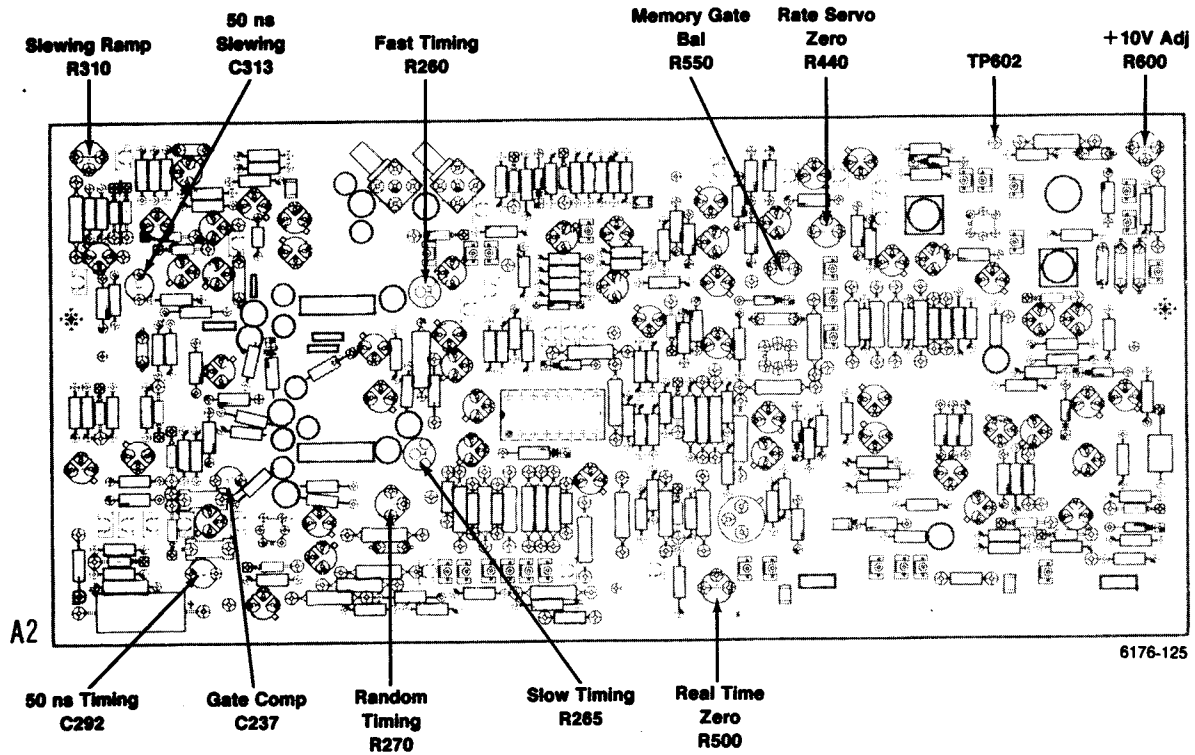

Figure 8-8. Location of Timing adjustments.

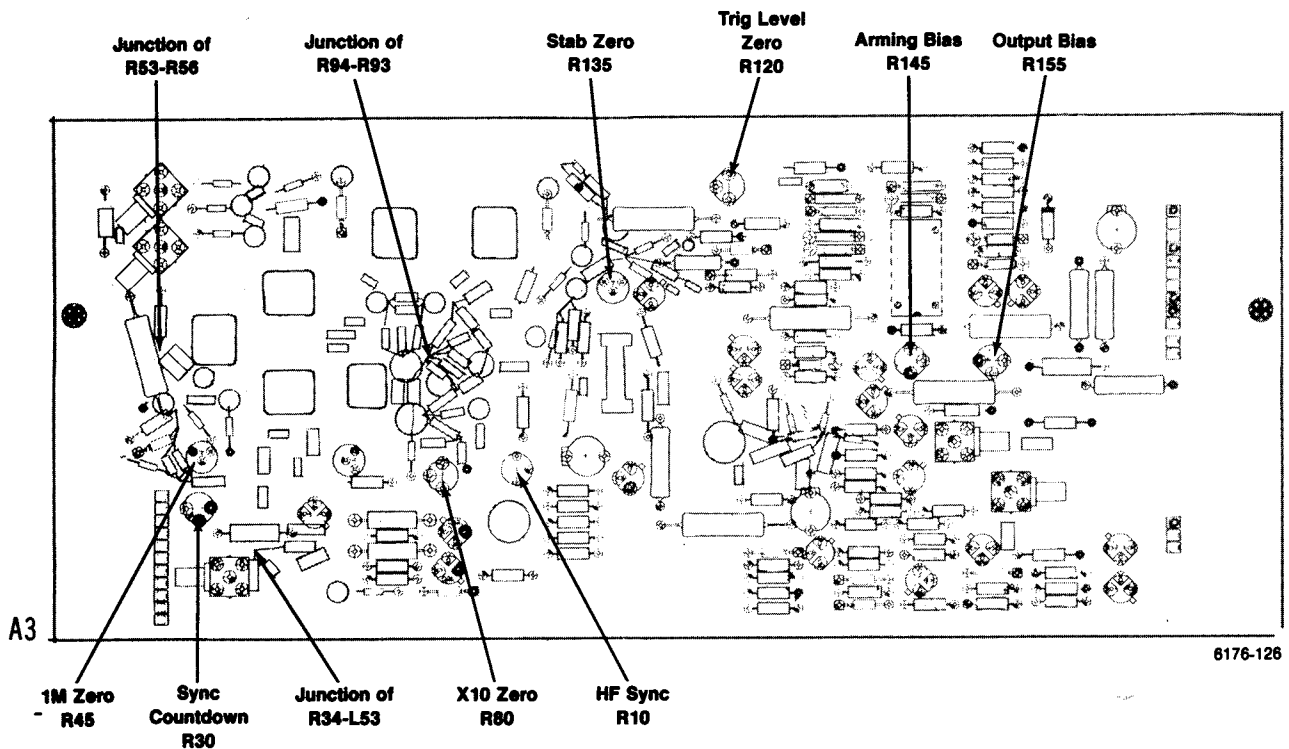

Figure 8-9. Location of Trigger adjustments.

# REPLACEABLE MECHANICAL PARTS

## PARTS ORDERING INFORMATION

Replacement parts are available from or through your local Tektronix, Inc. Field Office or representative.

Changes to Tektronix instruments are sometimes made to accommodate improved components as they become available, and to give you the benefit of the latest circuit improvements developed in our engineering department. It is therefore important, when ordering parts, to include the following information in your order: Part number, instrument type or number, serial number, and modification number if applicable.

If a part you have ordered has been replaced with a new or improved part, your local Tektronix, Inc. Field Office or representative will contact you concerning any change in part number.

Change information, if any, is located at the rear of this manual.

## ITEM NAME

In the Parts List, an Item Name is separated from the description by a colon (:). Because of space limitations, an Item Name may sometimes appear as incomplete. For further Item Name identification, the U.S. Federal Cataloging Handbook H6-1 can be utilized where possible.

## FIGURE AND INDEX NUMBERS

Items in this section are referenced by figure and index numbers to the illustrations.

## INDENTATION SYSTEM

This mechanical parts list is indented to indicate item relationships. Following is an example of the indentation system used in the description column.

```

1 2 3 4 5           Name & Description
Assembly and/or Component
Attaching parts for Assembly and/or Component
    ....END ATTACHING PARTS....
Detail Part of Assembly and/or Component
Attaching parts for Detail Part
    ....END ATTACHING PARTS....
Parts of Detail Part
Attaching parts for Parts of Detail Part
    ....END ATTACHING PARTS....
  
```

Attaching Parts always appear in the same indentation as the item it mounts, while the detail parts are indented to the right. Indented items are part of, and included with, the next higher indentation.

**Attaching parts must be purchased separately, unless otherwise specified.**

## ABBREVIATIONS

INCH	ELECTRN	ELECTRON	IN	INCH	SE	SINGLE END
NUMBER SIZE	ELEC	ELECTRICAL	INCAND	INCANDESCENT	SECT	SECTION
ACTR	ELECTLT	ELECTROLYTIC	INSUL	INSULATOR	SEMICOND	SEMICONDUCTOR
ADPTR	ELEM	ELEMENT	INTL	INTERNAL	SHLD	SHIELD
ALIGN	EPL	ELECTRICAL PARTS LIST	LPHLDR	LAMPHOLDER	SHLDR	SHOULDERED
AL	EOPT	EQUIPMENT	MACH	MACHINE	SKT	SOCKET
ASSEM	EXT	EXTERNAL	MECH	MECHANICAL	SL	SLIDE
ASSY	FIL	FILLISTER HEAD	MTG	MOUNTING	SLFLKG	SELF-LOCKING
ATTEN	FLEX	FLEXIBLE	NIP	NIPPLE	SLVG	SLEEVEING
AWG	FLH	FLAT HEAD	NON WIRE	NOT WIRE WOUND	SPR	SPRING
BD	FLTR	FILTER	OBD	ORDER BY DESCRIPTION	SQ	SQUARE
BRKT	FR	FRAME or FRONT	OD	OUTSIDE DIAMETER	SST	STAINLESS STEEL
BRS	FSTNR	FASTENER	OVH	OVAL HEAD	STL	STEEL
BRZ	FT	FOOT	PH BRZ	PHOSPHOR BRONZE	SW	SWITCH
BSHG	FXD	FIXED	PL	PLAIN or PLATE	T	TUBE
CAB	GSKT	GASKET	PLSTC	PLASTIC	TERM	TERMINAL
CAP	HDL	HANDLE	PN	PART NUMBER	THD	THREAD
CER	HEX	HEXAGON	PNH	PAN HEAD	THK	THICK
CHAS	HEX HD	HEXAGONAL HEAD	PWR	POWER	TNSN	TENSION
CKT	HEX SOC	HEXAGONAL SOCKET	RCPT	RECEPTACLE	TPG	TAPPING
COMP	HLCPS	HELICAL COMPRESSION	RES	RESISTOR	TRH	TRUSS HEAD
CONN	HLEXT	HELICAL EXTENSION	RGD	RIGID	V	VOLTAGE
COV	HV	HIGH VOLTAGE	RLF	RELIEF	VAR	VARIABLE
CPLG	IC	INTEGRATED CIRCUIT	RTNR	RETAINER	W	WITH
CRT	ID	INSIDE DIAMETER	SCH	SOCKET HEAD	WSHR	WASHER
DEG	IDENT	IDENTIFICATION	SCOPE	OSCILLOSCOPE	XFMR	TRANSFORMER
DWR	IMPLR	IMPELLER	SCR	SCREW	XSTR	TRANSISTOR

CROSS INDEX - MFR. CODE NUMBER TO MANUFACTURER

Mfr. Code	Manufacturer	Address	City, State, Zip Code
00779	AMP INC	P O BOX 3608	HARRISBURG PA 17105
01121	ALLEN-BRADLEY CO	1201 SOUTH 2ND ST	MILWAUKEE WI 53204
09922	BURNOY CORP	RICHARDS AVE	NORMALK CT 06852
12697	CLAROSTAT MFG CO INC	LOWER WASHINGTON ST	DOVER NH 03820
16179	OMNI SPECTRA CORP MICROWAVE COMPONENT DIV	21 CONTINENTAL BLVD	MERRIMACK NH 03054
18203	ENGELMANN MICROWAVE CO	SKYLINE DRIVE	MONTVILLE NJ 07045
22526	DU PONT E I DE NEMOURS AND CO INC DU PONT CONNECTOR SYSTEMS	30 HUNTER LANE	CAMP HILL PA 17011
22599	AMERACE CORP ESNA DIV	15201 BURBANK BLVD SUITE C	VAN NUYS CA 91411
24931	SPECIALTY CONNECTOR CO INC	2620 ENDRESS PLACE P O BOX D	GREENWOOD IN 46142
26805	OMNI SPECTRA INC MICROWAVE CONNECTOR DIV	140 FOURTH AVE	MALTHAM MA 02154
56878	SPS TECHNOLOGIES INC	HIGHLAND AVE	JENKINTOWN PA 19046
73743	FISCHER SPECIAL MFG CO	446 MORGAN ST	CINCINNATI OH 45206
74868	AMPHENOL R F OPERATIONS AN ALLIED CO	33 E FRANKLIN ST	DANBURY CT 06810
77900	SHAKEPROOF DIV OF ILLINOIS TOOL WORKS	SAINT CHARLES RD	ELGIN IL 60120
78189	ILLINOIS TOOL WORKS INC SHAKEPROOF DIVISION	ST CHARLES ROAD	ELGIN IL 60120
79136	MADES KOHINOOR INC	47-16 AUSTEL PLACE	LONG ISLAND CITY NY 11101
80009	TEKTRONIX INC	4900 S M GRIFFITH DR P O BOX 500	BEAVERTON OR 97077
83385	MICRODOT MANUFACTURING INC GREER-CENTRAL DIV	3221 N BIG BEAVER RD	TROY MI 48098
83486	ELCO INDUSTRIES INC	1101 SAMUELSON RD	ROCKFORD IL 61101
86928	SEASTROM MFG CO INC	701 SONORA AVE	GLENDALE CA 91201
90484	ITT SURPRENANT DIV	172 STERLING ST	CLINTON MA 01510
93907	TEXTRON INC CAMCAR DIV	600 18TH AVE	ROCKFORD IL 61101
98291	SEAELECTRO CORP	225 HOYT	MAMARONECK NY 10544
TK0392	NORTHWEST FASTENER SALES INC	7923 SM CIRRUS DRIVE	BEAVERTON OR 97005
TK0435	LEMIS SCREM CO	4114 S PEDRIA	CHICAGO IL 60609
TK0518	SUTCO MANUFACTURING CO	1819 SOUTH CENTRAL BAY 37	KEN MA 98031

Fig. & Index No.	Tektronix Part No.	Serial/Assembly No.		Qty	12345	Name & Description	Mfr.	
		Effective	Dscont				Code	Mfr. Part No.
1-1	366-1064-00			1		KNOB:GY,0.096 ID X 0.392 OD X 0.466	80009	366-1064-00
	213-0153-00			1		.SETSCREW:5-40 X 0.125,STL	TK0392	ORDER BY DESCR
-2	366-1148-01			1		KNOB:GY,0.16 ID X 0.706 OD X 0.6 H	80009	366-1148-01
	213-0153-00			2		.SETSCREW:5-40 X 0.125,STL	TK0392	ORDER BY DESCR
-3	366-1183-00			1		KNOB:GY,0.08 ID X 0.392 OD X 0.4 H	80009	366-1183-00
	213-0725-00			1		.SETSCREW:3-48 X 0.094,STL	56878	ORDER BY DESCR
-4	366-1101-00			1		KNOB:GY,0.127 ID X 0.706 OD X 0.6 H	80009	366-1101-00
	213-0153-00			1		.SETSCREW:5-40 X 0.125,STL	TK0392	ORDER BY DESCR
-5	366-1168-00			1		KNOB:RED,0.084 ID X 0.392 OD X 0.4 H	80009	366-1168-00
	213-0153-00			1		.SETSCREW:5-40 X 0.125,STL	TK0392	ORDER BY DESCR
-6	366-1258-00			1		KNOB:GY,0.252 ID X 0.706 OD X 0.74 H	80009	366-1258-00
	213-0153-00			2		.SETSCREW:5-40 X 0.125,STL	TK0392	ORDER BY DESCR
-7	358-0414-00			1		BUSHING,SLEEVE:0.125 ID X 0.312 OD X 0.21 L	80009	358-0414-00
-8	200-1011-01			1		CAP,KNOB:DIAL MINOOM	80009	200-1011-01
-9	366-1204-00			1		KNOB:GY,50MS-50NS,0.252 ID X 0.452 OD	80009	366-1204-00
	213-0153-00			2		.SETSCREW:5-40 X 0.125,STL	TK0392	ORDER BY DESCR
-10	331-0255-00			1		.DIAL,SCALE:MKD TIME/DIV SCALE	80009	331-0255-00
-11	366-1189-00			1		KNOB:GY,0.127 ID X 0.5 OD X 0.531	80009	366-1189-00
	213-0153-00			2		.SETSCREW:5-40 X 0.125,STL	TK0392	ORDER BY DESCR
-12	366-1058-48			1		KNOB:GRAY,7T11A	80009	366-1058-48
-13	214-1095-00			1		PIN,SPRING:0.187 L X 0.094 OD,STL,CD PL	22599	52-022-094-0187
-14	105-0076-04			1		RELEASE BAR,LCH:PLUG-IN UNIT	80009	105-0076-04
-15	214-1280-00			1		SPRING,HLCPS:0.14 OD X 1.126 L,TWIST LOOP	80009	214-1280-00
-16	358-0301-02			2		BUSHING,SLEEVE:0.16 ID X 0.205 OD	80009	358-0301-02
-17	-----			1		RES,VAR,NONNH:PNL,(2)10K OHM,20%,0.5W (SEE R570 REPL) (ATTACHING PARTS)		
-18	210-0583-00			1		NUT,PLAIN,HEX:0.25-32 X 0.312,BRS CD PL	73743	2X-20319-402
-19	210-0046-00			2		WASHER,LOCK:0.261 ID,INTL,0.018 THK,STL (END ATTACHING PARTS)	77900	1214-05-00-0541C
-20	-----			2		RESISTOR,VAR: (SEE R70,R610 REPL) (ATTACHING PARTS)		
-21	210-0583-00			2		NUT,PLAIN,HEX:0.25-32 X 0.312,BRS CD PL	73743	2X-20319-402
-22	210-0223-01			2		TERMINAL,LUG:0.26 ID,LOCKING,BRS TINNED (END ATTACHING PARTS)	86928	ORDER BY DESCR
-23	-----			2		RESISTOR,VAR: (SEE R679,R680 REPL) (ATTACHING PARTS)		
-24	358-0409-00			2		BWSG,MACH THD:0.25-32 X 0.159 ID,0.247 L	80009	358-0409-00
-25	210-0046-00			4		WASHER,LOCK:0.261 ID,INTL,0.018 THK,STL	77900	1214-05-00-0541C
-26	210-0471-00			2		NUT,SLEEVE:0.25-32 X 0.594 L X 0.312 HEX,AL (END ATTACHING PARTS)	80009	210-0471-00
-27	131-0779-00			2		JACK,TIP:U/M 0.08 OD TEST POINT	98291	0168010000208
-28	352-0216-00			1		HOLDER,TIP JACK:(2)JACKS,BLACK DELRIN (ATTACHING PARTS)	80009	352-0216-00
-29	213-0012-00			1		SCREEN,TPG,TC:4-40 X 0.375,TYPE T,FLH 100 DEG,STL	83385	ORDER BY DESCR
-30	210-0413-00			1		NUT,PLAIN,HEX:0.375-32 X 0.5,BRS CD PL	73743	3145-402
-31	210-0992-00			1		WASHER,FLAT:0.265 ID X 0.437 OD X 0.01 (END ATTACHING PARTS)	80009	210-0992-00
-32	175-1154-00			1		CABLE ASSY,RF:50 OHM COAX,3.5 L (J10 TO A2J11)	80009	175-1154-00
	175-0068-00			AR		.CABLE,RF:50 OHM COAX W/GRAY VINYL	90484	7259RG174A/U
-33	131-0155-00			1		.CONN,PLUG,ELEC:RF,FEMALE	74868	27-1
-34	-----			1		.CONN,PLUG,ELEC:3MM,MALE (PART OF CABLE ASSEMBLY)		
-35	131-0850-00			1		CONN,FEEDTHRU:3MM FEMALE EA END (ATTACHING PARTS)	26805	2084-5059-02
-36	220-0531-02			1		NUT,PLAIN,HEX:0.25-36 X 0.312 HEX,BRS NP	80009	220-0531-02
-37	210-0046-00			1		WASHER,LOCK:0.261 ID,INTL,0.018 THK,STL (END ATTACHING PARTS)	77900	1214-05-00-0541C
-38	198-2002-00			1		WIRE SET,ELEC: (J190 TO A2J189)	80009	198-2002-00
-39	131-0155-00			1		.CONN,PLUG,ELEC:RF,FEMALE	74868	27-1
-40	131-0579-00			1		.CONN,RCPT,ELEC:MINTR BAYONET,MALE	24931	38JS106-1
-41	333-1234-00			1		PANEL,FRONT:	80009	333-1234-00

Replaceable Mechanical Parts - 7T11A

Fig. & Index No.	Tektronix Part No.	Serial/Assembly No. Effective Dscont	Qty	12345	Name & Description	Mfr. Code	Mfr. Part No.
1-42	348-0235-00		2		SHLD GSMT,ELEK:FINGER TYPE,4.734 L	92101	ORDER BY DESCR
-43	-----		1		CIRCUIT BD ASSY:RANDOM SEQUENCE SM (SEE A9 REPL) (ATTACHING PARTS)		
-44	211-0156-00		1		SCREW,MACHINE:1-72 X 0.250,FLH,82 DEG,STL (END ATTACHING PARTS)	93907	ORDER BY DESCR
-45	-----		1		CIRCUIT BD ASSY:SLOPE SM (SEE A8 REPL) (ATTACHING PARTS)		
-46	211-0156-00		1		SCREW,MACHINE:1-72 X 0.250,FLH,82 DEG,STL (END ATTACHING PARTS)	93907	ORDER BY DESCR
-47	-----		1		CIRCUIT BD ASSY:TRIGGER AMPLIFIER SM (SEE A5 REPL) (ATTACHING PARTS)		
-48	211-0156-00		1		SCREW,MACHINE:1-72 X 0.250,FLH,82 DEG,STL (END ATTACHING PARTS)	93907	ORDER BY DESCR
-49	-----		1		CIRCUIT BD ASSY:TRIGGER SOURCE SM (SEE A6 REPL) (ATTACHING PARTS)		
-50	211-0156-00		2		SCREW,MACHINE:1-72 X 0.250,FLH,82 DEG,STL (END ATTACHING PARTS)	93907	ORDER BY DESCR
-51	-----		1		CIRCUIT BD ASSY:SCAN SM (SEE A7 REPL) (ATTACHING PARTS)		
-52	211-0156-00		2		SCREW,MACHINE:1-72 X 0.250,FLH,82 DEG,STL (END ATTACHING PARTS)	93907	ORDER BY DESCR
-53	342-0199-00		1		INSULATOR,FILM:SIDE PANEL,MYLAR	80009	342-0199-00
-54	210-0413-00		1		NUT,PLAIN,HEX:0.375-32 X 0.5,BRS CD PL	73743	3145-402
-55	386-1447-22		1		SUBPANEL,FRONT: (ATTACHING PARTS)	80009	386-1447-22
-56	213-0793-00		4		SCREW,TPG,TF:6-32 X 0.4375,TAPTITE,FILH (END ATTACHING PARTS)	83486	239-006-406043
-57	-----		1		CIRCUIT BD ASSY:COMMUTATOR SM FIXED (SEE A10 REPL) (ATTACHING PARTS)		
-58	211-0112-00		3		SCREW,MACHINE:2-56 X 0.375,FLH,100 DEG,STL	TK0435	ORDER BY DESCR
-59	210-0405-00		3		NUT,PLAIN,HEX:2-56 X 0.188,BRS CD PL	73743	12157-50
-60	210-0001-00		3		WASHER,LOCK:#2 INTL,0.013 THK,STL (END ATTACHING PARTS)	77900	1202-00-00-0541C
-61	179-1563-00		1		WIRING HARNESS:COMMUTATOR (A10 TO A3J31,J33,A2J342,J344)	80009	179-1563-00
-62	204-0410-00		1		BODY HALF,CONN:STATIONARY	80009	204-0410-00
-63	210-0223-00		3		TERMINAL,LUG:0.26 ID,LOCKING,BRZ TIN PL	86928	5441-37
-64	105-0075-00		1		BOLT,LATCH:	80009	105-0075-00
-65	214-1054-00		1		SPRING,FLAT:0.825 X 0.322,SST	80009	214-1054-00
-66	426-0499-09		1		FR SECT,PLUG-IN:BOTTOM (ATTACHING PARTS)	80009	426-0499-09
-67	211-0038-00		3		SCREW,MACHINE:4-40 X 0.312,FLH,100 DEG	TK0435	ORDER BY DESCR
-68	210-0586-00		3		NUT,PL,ASSEM MA:4-40 X 0.25,STL CD PL	78189	211-041800-00
-69	211-0105-00		3		SCREW,MACHINE:4-40 X 0.188,FLH,100 DEG (END ATTACHING PARTS)	TK0435	ORDER BY DESCR
-70	-----		1		CIRCUIT BD ASSY:TRIGGER (SEE A3 REPL)		
-71	136-0252-07		16		SOCKET,PIN CONN:M/O DIMPLE	22526	75060-012
-72	131-0265-00		5		CONN,RCPT,ELEC:MINTR,CKT BD MTD,MALE	98291	051-053-0000
-73	210-0707-00		2		EYELET,METALLIC:0.089 OD X 0.093 L	12697	ORDER BY DESCR
-74	344-0216-00		1		CLIP,ELECTRICAL:DIODE GROUND,CU BE GOLD PL	80009	344-0216-00
-75	352-0213-00		1		HOLDER,COAX CA:HORIZ CKT BD MT,DELTRIN	80009	352-0213-00
-76	361-0305-00		5		SPACER,SLEEVE:0.563 L X 0.105 ID,BRS	80009	361-0305-00
-77	214-0579-00		1		TERM,TEST POINT:BRS CD PL	80009	214-0579-00
-78	211-0155-00		4		SCREW,EXT RLV:4-40 X 0.375,PNH,SST,POZ	80009	211-0155-00
-79	361-0301-00		4		SPACER,POST:0.198 L W/4-40 THD ONE END	80009	361-0301-00
-80	386-1680-00		1		PLATE,RETAINING:ALUMINUM (ATTACHING PARTS)	80009	386-1680-00
-81	211-0513-00		2		SCREW,MACHINE:6-32 X 0.625,PNH,STL	93907	880-00032-003
-82	210-0457-00		2		NUT,PL,ASSEM MA:6-32 X 0.312,STL CD PL (END ATTACHING PARTS)	78189	511-061800-00



Fig. & Index No.	Tektronix Part No.	Serial/Assembly No. Effective Dscont	Qty	12345 Name & Description	Mfr. Code	Mfr. Part No.
1-83	166-0222-00		2	.SLEEVE,CAP.:0.187 ID X 0.225 OD X 0.325 L, .BRS ALBALOY PL	80009	166-0222-00
	198-2718-00		1	.WIRE SET,ELEC: (A3Q140 TO A3R151)	80009	198-2718-00
-84	-----		1	CIRCUIT 80 ASSY:TIMING (SEE A2 REPL)		
-85	210-0707-00		1	.EYELET,METALLIC:0.089 OD X 0.093 L	12697	ORDER BY DESCR
-86	131-0265-00		2	.CONN,RCPT,ELEC:MINTR,CKT 80 MTD,MALE	98291	051-053-0000
-87	136-0729-00		1	.SKT,PL-IN ELEK:MICROCKT,16 CONTACT	09922	01LB16P-108T
-88	136-0252-07		49	.SOCKET,PIN CONN:M/O DIMPLE	22526	75060-012
-89	136-0263-07		48	.SOCKET,PIN TERM:U/M 0.025 SQ PIN	22526	ORDER BY DESCR
	198-2717-00		1	.WIRE SET,ELEC: (A2R211 TO A3J162)	80009	198-2717-00
-90	220-0561-00		4	NUT,PLAIN,HEX:10-32 X 0.25 HEX,BRS NP	73743	16477-104
	334-3448-00		1	MARKER,IDENT:MARKED NOTICE	80009	334-3448-00
-91	-----		1	CIRCUIT 80 ASSY:INTERFACE (SEE A4 REPL)		
-92	351-0186-00		3	.POST,CKT 80 MTG:0.84 L X 0.25 OD,BRS	80009	351-0186-00
-93	131-0590-00		37	.TERMINAL,PIN:0.71 L X 0.025 SQ PH BRZ	80009	131-0590-00
	131-0592-00		40	.TERMINAL,PIN:0.885 L X 0.025 SQ BRS	80009	131-0592-00
	131-0608-00		14	.TERMINAL,PIN:0.365 L X 0.025 BRZ GLD PL	22526	48283-036
	131-0665-00		11	.TERMINAL,PIN:0.88 L X 0.025 SQ,BRS TIN PL	80009	131-0665-00
-94	351-0155-00		36	.INSULATOR,STDF:CONNECTOR,DELTRIN	80009	351-0155-00
-95	131-0604-00		41	.CONTACT,ELEC:CKT 80 SM,SPR,CU BE	80009	131-0604-00
-96	211-0292-00		8	.SCR,ASSEM MSHR:4-40 X 0.29,PNH,BRS NI PL	78189	51-040445-01
-97	351-0227-00		4	.POST,CKT 80 MTG:0.84 L X 0.25 OD,BRS	80009	351-0227-00
-98	-----		1	.ACTR ASSY,CAM S:SWEEP RANGE (SEE A45530B REPL)		
-99	200-0952-00		1	..COVER,CAM SM:20 ELEMENTS ..(ATTACHING PARTS)	80009	200-0952-00
-100	211-0022-00		2	..SCREW,MACHINE:2-56 X 0.188,PNH,STL	TK0435	ORDER BY DESCR
-101	210-0001-00		2	..WASHER,LOCK:#2 INTL,0.013 THK,STL ..(END ATTACHING PARTS)	77900	1202-00-00-0541C
-102	214-1139-02		1	..SPRING,FLAT:0.885 X 0.156 CU BE GRN CLR	80009	214-1139-02
	214-1139-03		1	..SPRING,FLAT:0.885 X 0.156 CU BE RED CLR	80009	214-1139-03
-103	214-1127-00		1	..ROLLER,DETENT:0.125 DIA X 0.125,SST	80009	214-1127-00
-104	354-0219-00		1	..RING,RETAINING:EXT,CRESCENT,U/O 0.25 DIA	79136	5103-25-S-Z0-R
-105	401-0054-00		1	..BEARING,CAM SM:FRONT,	80009	401-0054-00
-106	210-0405-00		2	..NUT,PLAIN,HEX:2-56 X 0.188,BRS CD PL	73743	12157-50
-107	384-0493-00		1	..SHAFT,STRAIGHT:3.875 L X 0.156 OD BRS,PLD .. HOLLOW	80009	384-0493-00
-108	105-0138-00		1	..ACTUATOR,CAM SM:SWEEP RANGE	80009	105-0138-00
-109	401-0068-00		1	..BEARING,CAM SM:REAR M/SHAFT RETAINER 0.83 .. DIA CAM	80009	401-0068-00
-110	210-0406-00		4	..NUT,PLAIN,HEX:4-40 X 0.188,BRS CD PL	73743	12161-50
-111	384-0494-00		1	.EXTENSION SHAFT:5.125 L X 0.125 OD,SST	80009	384-0494-00
-112	-----		1	.ACTR ASSY,CAM S:TIME/CM (SEE A45530A REPL)		
-113	200-0952-00		1	..COVER,CAM SM:20 ELEMENTS ..(ATTACHING PARTS)	80009	200-0952-00
-114	211-0022-00		2	..SCREW,MACHINE:2-56 X 0.188,PNH,STL	TK0435	ORDER BY DESCR
-115	210-0001-00		2	..WASHER,LOCK:#2 INTL,0.013 THK,STL ..(END ATTACHING PARTS)	77900	1202-00-00-0541C
-116	214-1139-00		1	..SPRING,FLAT:0.885 X 0.156 CU BE GLD CLR	80009	214-1139-00
	214-1139-03		1	..SPRING,FLAT:0.885 X 0.156 CU BE RED CLR	80009	214-1139-03
-117	214-1127-00		1	..ROLLER,DETENT:0.125 DIA X 0.125,SST	80009	214-1127-00
-118	354-0390 00		1	..RING,RETAINING:BASIC EXT,U/O 0.375 DIA	79136	5100-37-Z0
-119	401-0065-00		1	..BEARING,CAM SM:FRONT M/STOP GUIDE	80009	401-0065-00
-120	210-0405-00		2	..NUT,PLAIN,HEX:2-56 X 0.188,BRS CD PL	73743	12157-50
-121	105-0137-00		1	..ACTUATOR,CAM SM:TIME/CM	80009	105-0137-00
-122	401-0056-00		1	..BEARING,CAM SM:REAR,0.83 DIA CAM	80009	401-0056-00
-123	210-0406-00		4	..NUT,PLAIN,HEX:4-40 X 0.188,BRS CD PL	73743	12161-50
-124	384-0348-01		1	.EXTENSION SHAFT:9.161 L X 0.125 STEP OD	80009	384-0348-01
-125	213-0195-00		4	.SETSCREW:2-56 X 0.188,STL	TK0392	ORDER BY DESCR
-126	376-0051-00		1	.CPLG,SHAFT,FLEX:0.127 ID X 0.375 OD	80009	376-0051-00
-127	384-0488-00		1	.EXTENSION SHAFT:0.7 L X 0.125 OD,AL	80009	384-0488-00
-128	214-1190-00		1	.CPLG,SHAFT,RGD:0.125 OD TO 0.125 OD,AL	80009	214-1190-00

Replaceable Mechanical Parts - 7T11A

Fig. & Index No.	Tektronix Part No.	Serial/Assembly No.		Qty	12345	Name & Description	Mfr.		
		Effective	Dscont				Code	Mfr.	Part No.
1-129	-----			1		.RES,VAR,NONMH:PNL,2X20K OHM,0.5M (SEE A4R530 REPL) (ATTACHING PARTS)			
-130	210-0583-00			1		.NUT,PLAIN,HEX:0.25-32 X 0.312,BRS CD PL	73743		2X-20319-402
-131	210-0046-00			1		.WASHER,LOCK:0.261 ID,INTL,0.018 THK,STL (END ATTACHING PARTS)	77900		1214-05-00-0541C
-132	407-0803-00			1		.BRACKET,ELEC SM:BRASS	80009		407-0803-00
-133	214-1136-00			1		.ACTUATOR,SL SM:VARIABLE CAL	80009		214-1136-00
-134	351-0180-00			1		.GUIDE,SLIDE SM:SWITCH ACTUATOR	80009		351-0180-00
	198-2721-00			1		.WIRE SET,ELEC: (A4R530 TO A2)	80009		198-2721-00
-135	210-1096-00			1		.WASHER,KEY:0.375 ID X 0.175 THK,AL,0.75 OD	80009		210-1096-00
-136	220-0537-00			6		.NUT,PLAIN,PLATE:1-72 X 0.2 X 0.14,BRS CD PL (ATTACHING PARTS)	TK0518		ORDER BY DESCR
-137	211-0292-00			6		.SCR,ASSEM MSHR:4-40 X 0.29,PNH,BRS NI PL (END ATTACHING PARTS)	78189		51-040445-01
-138	-----			1		CIRCUIT BD ASSY:LOGIC (SEE A1 REPL)			
-139	136-0252-07			6		.SOCKET,PIN CONN:W/O DIMPLE	22526		75060-012
-140	136-0263-07			40		.SOCKET,PIN TERM:U/M 0.025 SQ PIN	22526		ORDER BY DESCR
-141	214-0579-00			1		.TERM,TEST POINT:BRS CD PL	80009		214-0579-00
-142	211-0155-00			3		.SCREW,EXT RLV:4-40 X 0.375,PNH,SST,POZ	80009		211-0155-00
-143	361-0238-00			3		.SPACER,POST:0.433 L,0.25 OD	80009		361-0238-00
-144	136-0352-00			1		.SOCKET,PIN TERM:U/M 0.02 DIA PINS	00779		50462-7
-145	136-0729-00			1		.SKT,PL-IN ELEC:MICROCKT,16 CONTACT	09922		D1LB16P-108T
-146	337-1238-01			1		SHIELD,ELEC:LEFT SIDE	80009		337-1238-01
-147	214-1061-00			1		CONTACT,ELEC:GROUNDING,CU BE	80009		214-1061-00
-148	426-0505-06			1		FR SECT,PLUG-IN:TOP (ATTACHING PARTS)	80009		426-0505-06
-149	211-0105-00			3		.SCREW,MACHINE:4-40 X 0.188,FLH,100 DEG (END ATTACHING PARTS)	TK0435		ORDER BY DESCR
-150	337-1163-01			1		SHIELD,ELEC:RIGHT SIDE	80009		337-1163-01
-151	386-1402-00			1		PANEL,REAR: (ATTACHING PARTS)	80009		386-1402-00
-152	213-0793-00			4		.SCREW,TPG,TF:6-32 X 0.4375,TAPTITE,FILH (END ATTACHING PARTS)	83486		239-006-406043
-153	179-1526-01			1		WIRING HARNESS:INTERFACE	80009		179-1526-01
-154	352-0161-00			1		.HLDR,TERM CONN:3 WIRE,BLACK	80009		352-0161-00
-155	352-0163-00			1		.HLDR,TERM CONN:5 WIRE,BLACK	80009		352-0163-00
-156	131-0707-00			25		.CONTACT,ELEC:22-26 AWG,BRS,CU BE GLD PL	22526		47439-000
-157	352-0164-00			1		.HLDR,TERM CONN:6 WIRE,BLACK	80009		352-0164-00
-158	131-0512-02			41		.CONTACT,ELEC:CONNECTOR,CU BE GOLD PL	00779		61941-1
-159	352-0168-00			1		.HLDR,TERM CONN:10 WIRE,BLACK	80009		352-0168-00

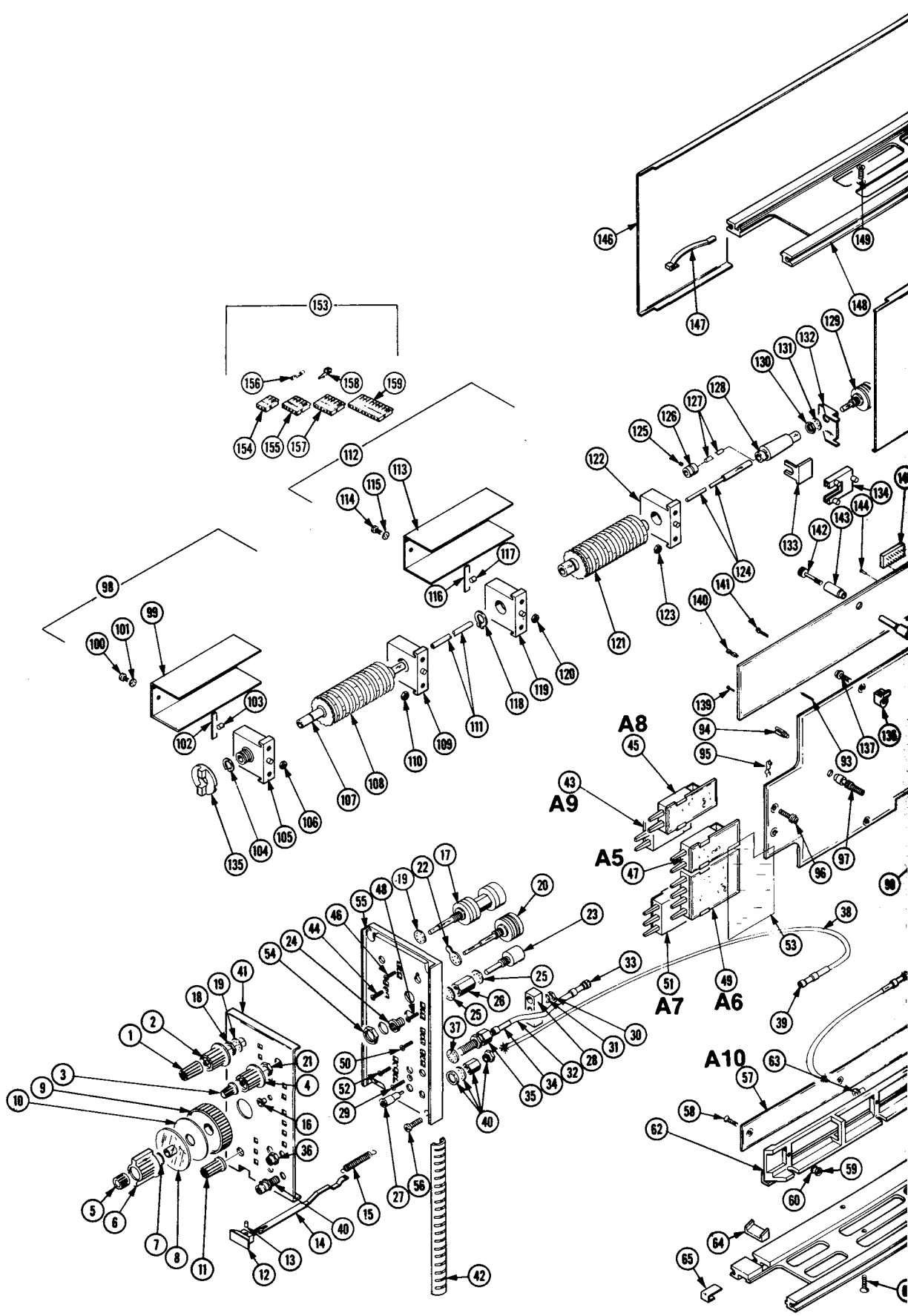

FIG. 1 EXPLODED VIEW

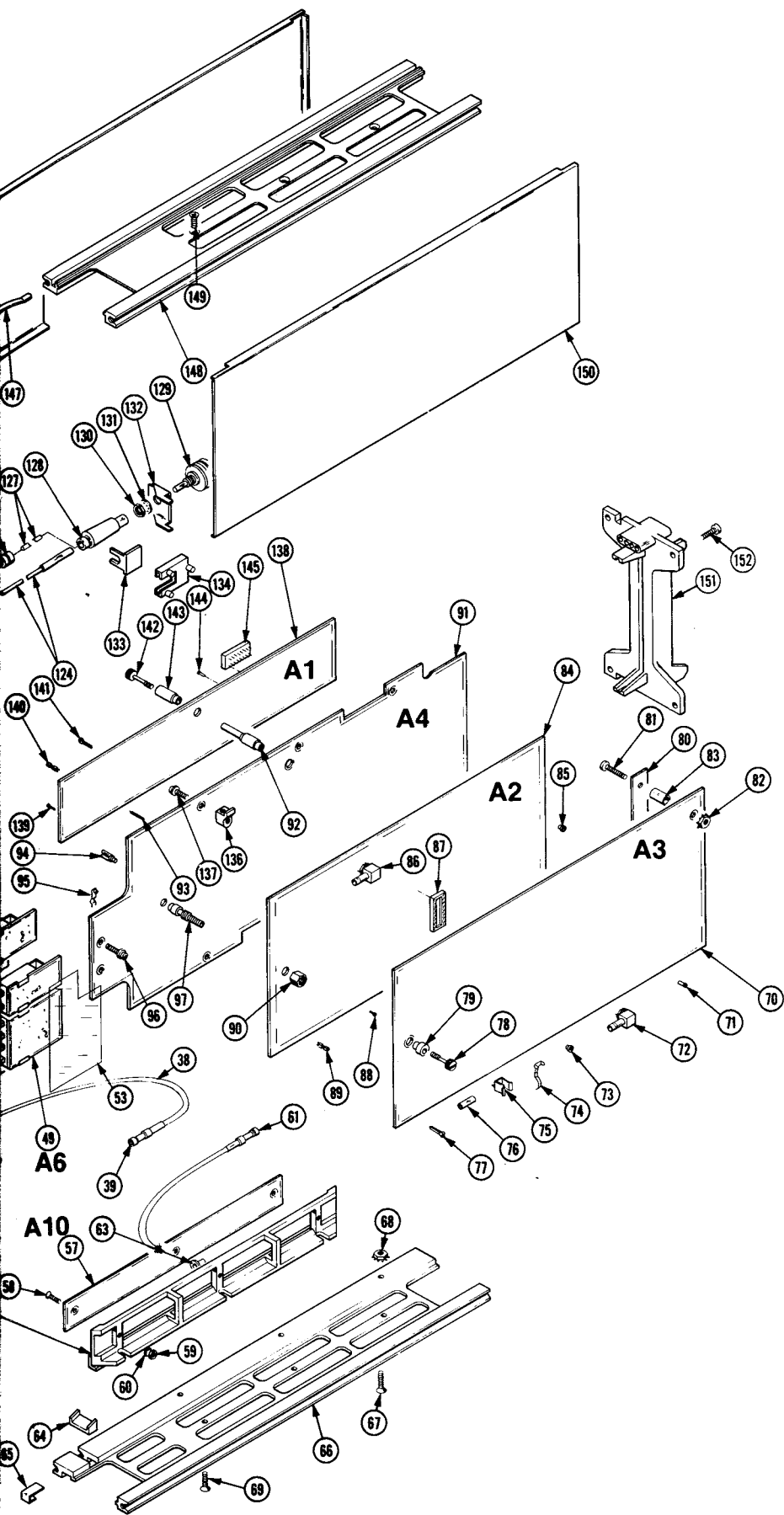

Fig. & Index No.	Tektronix Part No.	Serial/Assembly No.		Qty	12345	Name & Description	Mfr.	
		Effective	Dscont				Code	Mfr. Part No.
2-1	011-0059-02			1		ATTENUATOR,FXD:10:1 ATTEN,50 OHM,BNC	18203	A314-ES
-2	012-0057-01			1		CABLE ASSY,RF:50 OHM COAX,43.0 L	80009	012-0057-01
-3	015-1018-00			1		ADAPTER,CONN:3MM MALE TO BNC FEMALE	24931	29JP124-1
-4	015-1007-00			1		ADAPTER,CONN:GR-874 TO SMA MALE	16179	8181-2241-00
	070-6176-00			1		MANUAL,TECH:SERVICE,7T11A	80009	070-6176-00

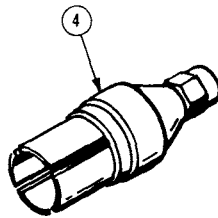
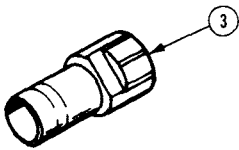
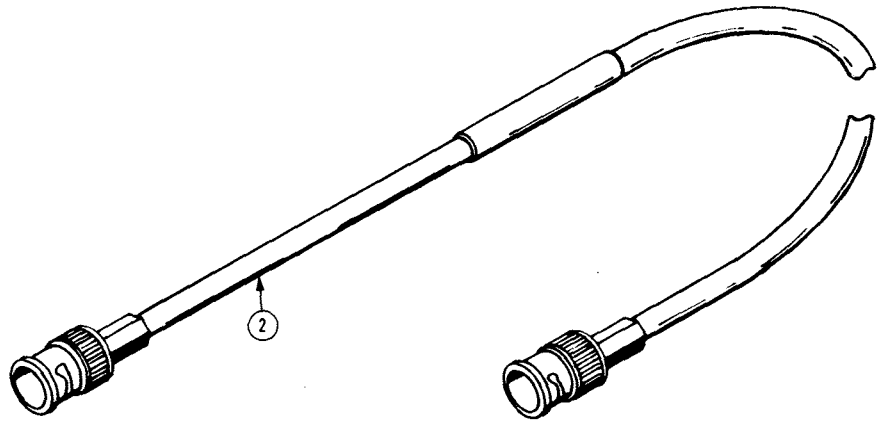
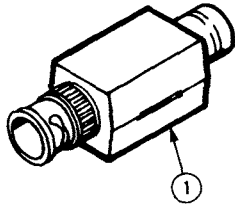

FIG. 2 ACCESSORIES

## **MANUAL CHANGE INFORMATION**

At Tektronix, we continually strive to keep up with latest electronic developments by adding circuit and component improvements to our instruments as soon as they are developed and tested.

Sometimes, due to printing and shipping requirements, we can't get these changes immediately into printed manuals. Hence, your manual may contain new change information on following pages.

A single change may affect several sections. Since the change information sheets are carried in the manual until all changes are permanently entered, some duplication may occur. If no such change pages appear following this page, your manual is correct as printed.

# Scans By *Artek Media*

Artek Media  
1042 Plummer Cir. SW  
Rochester, MN 55902

[www.artekmedia.com](http://www.artekmedia.com)

"High resolution scans of obsolete technical manuals"

If your looking for a quality scanned technical manual in PDF format please visit our WEB site at [www.artekmedia.com](http://www.artekmedia.com) or drop us an email at [manuals@artekmedia.com](mailto:manuals@artekmedia.com) and we will be happy to email you a current list of the manuals we have available.

If you don't see the manual you need on the list drop us a line anyway we may still be able to point you to other sources. If you have an existing manual you would like scanned please write for details, This can often be done very reasonably in consideration for adding your manual to our library.

Typically the scans in our manuals are done as follows;

- 1) Typed text pages are typically scanned in black and white at 300 dpi.
- 2) Photo pages are typically scanned in gray scale mode at 600 dpi
- 3) Schematic diagram pages are typically scanned in black and white at 600 dpi unless the original manual had colored high lighting (as is the case for some 70's vintage Tektronix manuals).

If you purchased this manual from us (typically through our Ebay name of ArtekMedia) thank you very much. If you received this from a well-meaning "friend" for free we would appreciate your treating this much like you would "share ware". By that we mean a donation of at least \$5-10 per manual is appreciated in recognition of the time (a manual can take as much as 40 hours to reproduce, book, link etc.), energy and quality of effort that went into preserving this manual. Donations via PayPal go to: [manuals@artekmedia.com](mailto:manuals@artekmedia.com) or can be mailed to us the address above.

Thanks



Dave & Lynn Henderson  
Artek Media