



**PLEASE CHECK FOR CHANGE INFORMATION
AT THE REAR OF THIS MANUAL.**

**7T11
SAMPLING
SWEEP UNIT**

INSTRUCTION MANUAL

Tektronix, Inc.
P.O. Box 500
Beaverton, Oregon 97077

Serial Number 3243824

070-0986-00
Product Group 42

First Printing MAY 1970
Revised JUL 1982

Scans By *Artek Media*

Artek Media
1042 Plummer Cir. SW
Rochester, MN 55902

www.artekmedia.com

"High resolution scans of obsolete technical manuals"

If you're looking for a quality scanned technical manual in PDF format please visit our WEB site at www.artekmedia.com or drop us an email at manuals@artekmedia.com and we will be happy to email you a current list of the manuals we have available.

If you don't see the manual you need on the list drop us a line anyway we may still be able to point you to other sources. If you have an existing manual you would like scanned please write for details, This can often be done very reasonably in consideration for adding your manual to our library.

Typically the scans in our manuals are done as follows;

- 1) Typed text pages are typically scanned in black and white at 300 dpi.
- 2) Photo pages are typically scanned in gray scale mode at 600 dpi
- 3) Schematic diagram pages are typically scanned in black and white at 600 dpi unless the original manual had colored high lighting (as is the case for some 70's vintage Tektronix manuals).

If you purchased this manual from us (typically through our Ebay name of ArtekMedia) thank you very much. If you received this from a well-meaning "friend" for free we would appreciate your treating this much like you would "share ware". By that we mean a donation of at least \$5-10 per manual is appreciated in recognition of the time (a manual can take as much as 40 hours to reproduce, book, link etc.), energy and quality of effort that went into preserving this manual. Donations via PayPal go to: manuals@artekmedia.com or can be mailed to us the address above.

Thanks



Dave & Lynn Henderson
Artek Media



WARRANTY

All Tektronix instruments are warranted against defective materials and workmanship for one year. Tektronix transformers, manufactured in our plant, are warranted for the life of the instrument.

Any questions with respect to the warranty mentioned above should be taken up with your Tektronix Field Engineer.

Tektronix repair and replacement-part service is geared directly to the field, therefore all requests for repairs and replacement parts should be directed to the Tektronix Field Office or representative in your area. This procedure will assure you the fastest possible service. Please include the instrument Type and Serial or Model Number with all requests for parts or service.

Specifications and price change privileges reserved.

Copyright© 1970 by Tektronix, Inc., Beaverton, Oregon. Printed in the United States of America. All rights reserved. Contents of this publication may not be reproduced in any form without permission of the copyright owner.

TABLE OF CONTENTS

	Page
SECTION 1 SPECIFICATION	
General Information	1-1
Instrument Features	1-1
Electrical Characteristics	1-1
Mechanical Characteristics	1-4
SECTION 2 OPERATING INSTRUCTIONS	
General Information	2-1
Installing the 7T11	2-1
TIME/DIV Readout	2-2
Controls and Connectors	2-3
First-Time Operation	2-4
Setup Information	2-5
Adjusting SWEEP CAL	2-5
Observing a Fastrise Pulse	2-6
Triggering Considerations	2-7
Trigger Rate	2-8
SWEEP RANGE Control	2-8
TIME/DIV Settings	2-9
TIME POSITION Control	2-9
SCAN Control	2-10
TRIG LEVEL and STABILITY Controls	2-10
Trigger Pushbutton Switches	2-11
PULSE OUT Connector	2-11
Use of Real Time Mode	2-11
Using the 7M11 Delay Line	2-11
SECTION 3 CIRCUIT DESCRIPTION	
THEORY OF OPERATION	
Real-Time Sampling Theory	3-1
General	3-1
Staircase Ramp	3-2
Lead Time	3-3
Samples/Division	3-3
Summary	3-3
Additional Real-Time Circuits	3-4
Controls Affecting Timing and Delay	3-5
Important Waveforms	3-6
Sequential Sampling Theory	3-9
Additional Circuits Required	3-9
Constructing The Display	3-11
Waveform Relationships	3-11
Factors Affecting Dot Density	3-13
Blanking Circuits	3-14
Unavoidable Delay	3-15

TABLE OF CONTENTS (cont)

Random Sampling Theory	3-16
Introduction	3-16
Random Block Diagram	3-16
Random Operation	3-18
Waveform Relationships	3-18
CIRCUIT ANALYSIS	
Relationship to Vertical Unit	3-20
Triggering Circuits	3-22
Internal Triggering	3-22
External Triggering	3-23
Trigger Slope Amplifier	3-24
Trigger (X10) Amplifier	3-24
Schmitt Trigger	3-24
HF SYNC	3-26
Arming and Output Tunnel Diodes	3-26
Output Tunnel Diode Circuits	3-28
Real and Equivalent-Time Logic	3-29
Start Multivibrator	3-29
TTH Circuit	3-30
Horizontal Amplifier	3-33
Real-Time Multivibrator	3-34
Horizontal Memory	3-35
Output Amplifiers	3-35
Hold-off Multivibrator (HOMV)	3-35
Slewing Ramp	3-39
Strobe Drivers	3-41
Slow Ramp Generator	3-41
Slow Ramp Inverter and Time Position Amp	3-43
Dot Position Memory	3-44
Ratemeter	3-45
Ratemeter Start Correction Circuits	3-47
Timing Switches	3-47
Readout Logic	3-48
SECTION 4 MAINTENANCE	
Preventive Maintenance	4-1
Troubleshooting	4-1
Transistor and IC Pin Arrangement	4-3
7T11 Troubleshooting Procedure	4-5
Soldering Techniques	4-7
Component Replacement	4-7
Circuit Boards	4-8
Pin Sockets and Connectors	4-8
Tunnel Diode CR28	4-8
Switch Replacement	4-9
Instrument Repackaging	4-11
Circuit Board Connections and Component Locations	4-12 to 4-18

TABLE OF CONTENTS (cont)

SECTION 5	PERFORMANCE CHECK/CALIBRATION	
	Introduction	5-1
	Test Equipment Required	5-1
	Short Form Procedure	5-2
	Calibration and Performance Check	5-4
	Adjust +10 Volts	5-7
	Check Manual Scan and Adjust Sweep	
	Cal and Position	5-7
	Timing Accuracy	5-7
	Time Position Range	5-9
	Adjust Timing	5-9
	Adjust Random Timing	5-11
	Adjust Trig Level	5-12
	Adjust Stability	5-12
	Adjust External Trigger Zero	5-13
	Adjust HF Sync	5-13
	Adjust Output Bias	5-14
	Check Triggering	5-15
	Check Display Jitter	5-16
	Check Pulse Out into 50 Ω	5-19
	Check Trigger Kickout	5-19
	Trigger Holdoff	5-20
	Strobe Kickback into Trigger	5-20
	Minimum Trigger Rate in Random	5-21
	Repetition Scan Rate	5-21
	Sweep Out Range	5-21
	External Input	5-21
SECTION 6	ELECTRICAL PARTS LIST	
	Abbreviations and Symbols	
	Parts Ordering Information	
	Index of Electrical Parts List	
	Electrical Parts List	
SECTION 7	DIAGRAMS AND MECHANICAL PARTS ILLUSTRATIONS	
	Diagrams	
	Mechanical Parts Illustrations	
	Accessories	
	Repackaging Instructions	
SECTION 8	MECHANICAL PARTS LIST	
	Mechanical Parts List Information	
	Index of Mechanical Parts Illustrations	
	Mechanical Parts List	

CHANGE INFORMATION

Abbreviations and symbols used in this manual are based on or taken directly from IEEE Standard 260 "Standard Symbols for Units", MIL-STD-12B and other standards of the electronics industry. Change information, if any, is located at the rear of this manual.



Fig. 1-1. 7T11 Sampling Sweep Unit.

SECTION 1

SPECIFICATION

Change information, if any, affecting this section will be found at the rear of the manual.

General Information

The 7T11 Sampling unit is designed for use in Tektronix 7000-series oscilloscopes. Several plug-in combinations, including a 7T11, are shown in Fig. 1-2. A 7S11 must be in the compartment to the left of, and adjacent to, the compartment in which the 7T11 is operated. Therefore, two 7T11's are not used in the same mainframe.

In Fig. 1-2A the 7T11 is shown in the "A" Horizontal compartment of the oscilloscope. The Vertical Mode and Horizontal Mode pushbuttons, providing useful presentations, are designated for plug-in configurations A, B, and C. For the configuration of Fig. 1-2A, four combinations are shown. Plug-in arrangements other than those shown in Fig. 1-2 are possible.

An alternate to the configuration shown in Fig. 1-2B is with the "LEFT" or "B" or both of these mainframe compartments empty. The 7M11 may be used in any available mainframe compartment or operated out of the mainframe. For further information, see the Operating Instructions section of this manual under the heading of General Operating Information.

Instrument Features

The 7T11 features a wide range of sweep rates using real-time and equivalent-time sampling. Concentric switches select the sweep range and time position range in different combinations for the time/div desired. On equivalent time ranges, either sequential or random sampling is available. Use of random sampling permits display of the leading edge of fast-rise input signals without the use of a signal delay line (such as the 7M11) or a pretrigger pulse from the signal source.

Internal triggering, or any of three modes of external triggering can be selected by using the front panel pushbuttons. A Schmitt trigger circuit is used except when HF SYNC is selected. With EXT 50 Ω input selected, the Schmitt circuit provides jitter free triggering from input trigger signals from DC to 1 GHz. The display is

free of trigger jitter or double triggering, even at low trigger repetition rates or when using a square wave as the input trigger signal. A recovery time control is not needed.

Selecting EXT HF SYNC permits using frequencies of 1 GHz to approximately 12 GHz as the trigger input source. With HF SYNC selected, the signal connected to the TRIG INPUT connector is routed to a built-in synchronizer, thus permitting X band signals to be viewed.

Excellent sweep linearity is provided when using the 7T11. The timing circuitry in the 7T11 uses a time measurement rather than a time programming process for horizontal sample positioning on all equivalent-time sweep ranges. During both random and Sequential operation the horizontal position of the dot on the screen is determined by measuring the time interval between strobe and trigger. This method results in improved timing linearity and a reduction in display jitter. The accuracy of sweep timing and linearity make it unnecessary, during equivalent time sampling, to exclude the sweep start from accuracy specifications.

Characteristics

The following characteristics apply over an ambient temperature range of 0°C to +50°C at altitudes up to 15,000 feet and after a five-minute warmup, providing the instrument was calibrated at a temperature between +20°C and +30°C. During non-operation, do not subject the 7T11 to altitudes above 50,000 feet or to temperatures below -55°C.

ELECTRICAL CHARACTERISTICS

Characteristic	Performance Requirement
SWEEP RATES	
TIME/DIV	Calibrated from 5 ms/div to 10 ps/div, selectable in a 1, 2, 5 sequence, using SWEEP RANGE and TIME/DIV controls.

ELECTRICAL CHARACTERISTICS (cont)

Characteristic	Performance Requirement
----------------	-------------------------

SWEEP RATES (cont)

Equivalent Time	5 μ s/div to 10 ps/div using the 50 μ s to 50 ns Time Position Ranges.
Accuracy	Within 3%.
Real Time	5 ms/div to .1 μ s/div using the 50 ms to .5 ms Time Position Ranges.

ELECTRICAL CHARACTERISTICS (cont)

Characteristic	Performance Requirement
----------------	-------------------------

SWEEP RATES (cont)

Accuracy	
On 50 ms TIME POS RNG	Within 3%, beginning 250 μ s after undelayed sweep start.
On 5 ms TIME POS RNG	Within 3%, beginning 25 μ s after undelayed sweep start.

Plug-In Configuration	Mainframe Switching																																																						
	VERTICAL MODE	HORIZONTAL MODE																																																					
<table border="1"> <thead> <tr> <th>Left</th> <th>Right</th> <th>"A"</th> <th>"B"</th> </tr> </thead> <tbody> <tr> <td>7S11</td> <td>7S11</td> <td>7T11</td> <td>7M11</td> </tr> </tbody> </table> <p>(A)</p>	Left	Right	"A"	"B"	7S11	7S11	7T11	7M11	<table border="1"> <thead> <tr> <th>LEFT</th> <th>ALT</th> <th>ADD</th> <th>CHOP</th> <th>RIGHT</th> </tr> </thead> <tbody> <tr> <td>X</td> <td></td> <td></td> <td></td> <td></td> </tr> <tr> <td></td> <td></td> <td>X</td> <td></td> <td></td> </tr> <tr> <td></td> <td></td> <td></td> <td>X</td> <td></td> </tr> <tr> <td></td> <td></td> <td></td> <td></td> <td>X</td> </tr> </tbody> </table>	LEFT	ALT	ADD	CHOP	RIGHT	X							X						X						X	<table border="1"> <thead> <tr> <th>A</th> <th>ALT</th> <th>CHOP</th> <th>B</th> </tr> </thead> <tbody> <tr> <td>X</td> <td></td> <td></td> <td></td> </tr> <tr> <td>X</td> <td></td> <td></td> <td></td> </tr> <tr> <td>X</td> <td></td> <td></td> <td></td> </tr> <tr> <td>X</td> <td></td> <td></td> <td></td> </tr> </tbody> </table>	A	ALT	CHOP	B	X				X				X				X			
Left	Right	"A"	"B"																																																				
7S11	7S11	7T11	7M11																																																				
LEFT	ALT	ADD	CHOP	RIGHT																																																			
X																																																							
		X																																																					
			X																																																				
				X																																																			
A	ALT	CHOP	B																																																				
X																																																							
X																																																							
X																																																							
X																																																							
<table border="1"> <thead> <tr> <th>7A--</th> <th>7S11</th> <th>7T11</th> <th>7B--</th> </tr> </thead> <tbody> <tr> <td></td> <td></td> <td></td> <td></td> </tr> </tbody> </table> <p>(B)</p>	7A--	7S11	7T11	7B--					<table border="1"> <tbody> <tr> <td>X</td> <td></td> <td></td> <td></td> <td></td> </tr> <tr> <td></td> <td></td> <td></td> <td></td> <td>X</td> </tr> <tr> <td></td> <td>X</td> <td></td> <td></td> <td></td> </tr> </tbody> </table>	X									X		X				<table border="1"> <tbody> <tr> <td></td> <td></td> <td></td> <td>X</td> </tr> <tr> <td>X</td> <td></td> <td></td> <td></td> </tr> <tr> <td></td> <td></td> <td>X</td> <td></td> </tr> </tbody> </table>				X	X						X																			
7A--	7S11	7T11	7B--																																																				
X																																																							
				X																																																			
	X																																																						
			X																																																				
X																																																							
		X																																																					
<table border="1"> <thead> <tr> <th>blank</th> <th>7S11</th> <th>7S11</th> <th>7T11</th> </tr> </thead> <tbody> <tr> <td></td> <td></td> <td></td> <td></td> </tr> </tbody> </table> <p>(C)</p>	blank	7S11	7S11	7T11					<table border="1"> <tbody> <tr> <td></td> <td></td> <td></td> <td>X</td> </tr> <tr> <td></td> <td></td> <td></td> <td>X</td> </tr> <tr> <td></td> <td></td> <td></td> <td>X</td> </tr> </tbody> </table>				X				X				X	<table border="1"> <tbody> <tr> <td>X</td> <td></td> <td></td> <td></td> </tr> <tr> <td></td> <td></td> <td></td> <td>X</td> </tr> <tr> <td></td> <td></td> <td>X</td> <td></td> </tr> </tbody> </table>	X							X			X																						
blank	7S11	7S11	7T11																																																				
			X																																																				
			X																																																				
			X																																																				
X																																																							
			X																																																				
		X																																																					

Fig. 1-2. Several plug-in configurations using the 7T11 and a 7000-series oscilloscope.

ELECTRICAL CHARACTERISTICS (cont)

Characteristic	Performance Requirement
SWEEP RATES (cont)	
On 0.5 ms TIME POS RNG	Within 3%, beginning 2.5 μ s after undelayed sweep start, or after 500 ns from start of displayed portion of sweep.
VARIABLE (TIME/DIV) Range	Extends fastest sweep rate to at least 4 ps/div. Permits increasing the speed of all sweep rates to at least 2.5 times the calibrated speed.
TRIGGERING	
Input Resistance	
EXT 50 Ω	50 Ω within 10%.
EXT 1 M Ω	1 M Ω within 5%.
EXT HF SYNC	1 M Ω within 5%.
*Sinewave Triggering Internal	
Sensitivity Range	
X1 Trig Amp	50 mV to 1 V (5 kHz to 500 MHz)
X10 Trig Amp	5 mV to 1 V (5 kHz to 50 MHz)
	*NOTE: Trigger circuits will operate to DC with pulse triggering, except for HF Sync.
External	
50 Ω Input	
Sensitivity Range	
X1 Trig Amp	5 mV to 2 V (P-P), DC to 1 GHz.
X10 Trig Amp	0.5 mV to 2 V (P-P), 1 kHz to 50 MHz.
Safe Overload	2 V (DC + peak AC).

ELECTRICAL CHARACTERISTICS (cont)

Characteristic	Performance Requirement
TRIGGERING (cont)	
1 M Ω Input	
Sensitivity Range	
X1 Trig Amp	5 mV to 2 V (P-P), DC to 100 MHz.
X10 Trig Amp	0.5 mV to 2 V (P-P), 1 kHz to 50 MHz.
Safe Overload	100 V DC or 100 V (P-P) to 1 kHz; derated 6 dB/octave above 1 kHz to 5 V (P-P).
HF SYNC Input	
Sensitivity Range	10 mV to 500 mV (peak-peak) at 1 GHz; 200 mV to 500 mV (peak-peak) at 12.4 GHz.
Safe Overload	2 V (peak-peak)
Display Jitter	
50 Ω and 1 M Ω Triggering	
Sequential Mode	10 ps or less at fastest SWEEP RANGE position (fully CCW); 0.4 divisions or less at remaining six positions of SWEEP RANGE; measurements made under optimum trigger conditions.
Random Mode	30 ps or less at fastest SWEEP RANGE position (fully CCW); one division or less at remaining six positions of SWEEP RANGE; measurements made under optimum trigger conditions.
HF SYNC	
Random or Sequential Mode	20 ps or less with a 12.4 GHz, 200 mV (peak-peak) signal; measured under optimum trigger conditions.

ELECTRICAL CHARACTERISTICS (cont)

Characteristic	Performance Requirement
TRIGGERING (cont)	
PULSE OUT (into 50 Ω)	
Amplitude	Positive-going pulse of at least 400 mV.
Risetime	2.5 ns or less.
Trigger Kickout	2 mV or less into 50 Ω (except HF SYNC).
Minimum Trigger Rate in RANDOM Mode	100 Hz.

SLOW RAMP GENERATOR

Scan Rate	
REPETITIVE SCAN	Continuously variable from less than 2 sweeps/sec to at least 40 sweeps/sec.

HORIZONTAL DEFLECTION SYSTEM

Deflection Factor	
SWEEP CAL	Permits adjustment of deflection factor for all 7000-series mainframes.

ELECTRICAL CHARACTERISTICS (cont)

Characteristic	Performance Requirement
HORIZONTAL DEFLECTION SYSTEM (cont)	
EXTERNAL INPUT	
Input Resistance	100 kΩ within 10%.
Deflection Factor	Continuously variable from 10 V to 1 V/div.
Maximum Input Voltage	100 V (DC + peak AC).
SWEEP OUT	1 V/div within 2% (through a 10 kΩ ±1% resistor).

MECHANICAL CHARACTERISTICS

Dimensions	
Height	≈ 5 inches.
Width	≈ 2¾ inches.
Length (including front panel knobs and rear connector)	≈ 14½ inches.
Construction	Aluminum alloy chassis with epoxy laminated circuit boards. Front panel is anodized aluminum.
Accessories	An illustrated list of the accessories supplied with the 7T11 is at the end of the Mechanical Parts List pullout pages.

SECTION 2

OPERATING INSTRUCTIONS

Change information, if any, affecting this section will be found at the rear of the manual.

General Information

This section covers installation, first time operation, function of front panel controls and connectors, and general operation of the 7T11 Sampling Sweep Unit.

The 7T11 is intended for use in the Tektronix 7000-series oscilloscopes. Use of the 7T11 with a 7S11 Sampling Unit and any of a variety of S-series Sampling Heads provides a sampling system adaptable to a wide range of applications.

Real-time sampling is provided at the three slowest sweep rate settings of the 7T11 Sweep Range switch. Sampling is in equivalent-time for the remaining four positions of the Sweep Range switch. On these four ranges either sequential or random equivalent-time sampling may be selected.

The 7T11 sweep may be synchronized using an internal or external triggering source. External signals from DC up to approximately 12 GHz can be used as the trigger source. A trigger amplifier providing X10 amplification is available.

NOTE

Internal trigger signals are not routed through the trigger source switches on the oscilloscope due to the frequencies involved and noise considerations. Selection of the trigger source is made on the front panel of the plug-ins.

Triggering signals travel between plug-in units along 50 Ω coaxial or strip lines. These signals travel between plug-in units using contacts on connector strips fastened to the sides of the plug-ins. A connector strip is shown in the photograph of Fig. 2-1. Since the strobe pulses also travel between a 7T11 and a 7S11 plug-in through contacts on the connector strips, these units must be located in adjacent oscilloscope compartments.

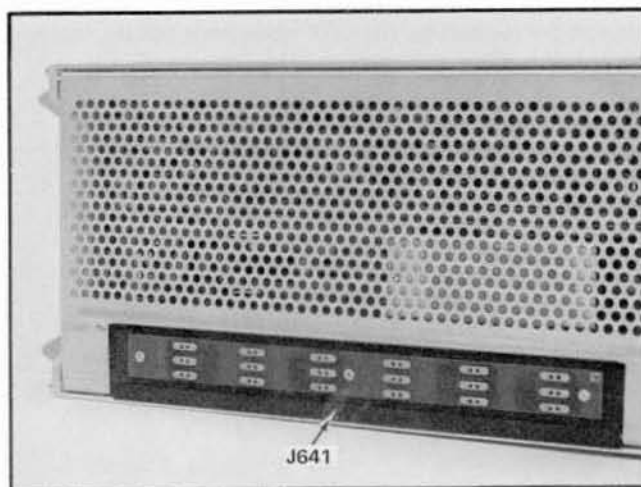

Fig. 2-1. Connector J641 (fixed shoe), providing interconnection between 7T11 and 7S11 for strobe and trigger signals.

Installing the Type 7T11 in the Oscilloscope

The 7T11 is designed to drive the horizontal deflection plates of the oscilloscope CRT, and therefore is installed in the right-hand compartment of the oscilloscope. When only one Type 7T11 and one 7S11 are used in a 7000-series oscilloscope providing two vertical and two horizontal compartments, the 7T11 is inserted in the left-hand horizontal compartment and the 7S11 in the right-hand vertical compartment. This provides an interconnecting path between the 7T11 and the 7S11 for strobe and trigger signals.

To insert the 7T11 into the oscilloscope compartment, align the grooves along the top and bottom of the plug-in with the upper and lower slide rails in the oscilloscope compartment. The unit slides straight in and self-locks itself in place. The plug-in is removed by pulling straight out on the plastic button labeled 7T11.

Mating the 7T11 to the Oscilloscope

The 7T11 horizontal gain must be matched to the horizontal deflection factor of the CRT in the oscilloscope. Horizontal gain is set using the Sweep Cal control (screw-driver adjustment) located on the 7T11 front panel. A

Operating Instructions—7T11

method of adjusting the Sweep Cal is discussed in the First Time Operation Procedure later in this section. This adjustment must be reset each time the 7T11 is transferred between oscilloscopes, and when a considerable change in ambient temperature occurs.

TIME/DIV Readout

The 7T11 TIME/DIV setting selected is displayed near the top of the CRT except when the 7T11 is used in a oscilloscope without readout circuitry. The horizontal position of the readout on the CRT corresponds to the horizontal position of the oscilloscope compartment in use.

The TIME/DIV selected at the 7T11 front panel is displayed on the CRT using the digits 1, 2, or 5 followed by one or two zeros if required. The TIME/DIV readout does not use decimal points. The displayed digits are followed by the units-of-measure readout. With the 7T11 the units-of-measure displayed will be ms/div, μ s/div, ns/div or ps/div. If the VARIABLE (CAL IN) switch is in the out position the symbol used to indicate less than (<), is displayed preceding the TIME/DIV readout as a warning that the display is uncalibrated. The intensity of the readout is independently adjustable by a front panel control on the oscilloscope, which also permits the readout to be switched off.



Fig. 2-2. 7T11 front panel.

FRONT PANEL CONTROLS AND CONNECTORS

All controls required for operation of the 7T11 are located on the front panel of the unit (see Fig. 2-2). Controls, pushbuttons, and connectors associated with triggering are located along the right side of the front panel and are included in an area outlined in green. The SCAN control, pushbuttons, and an external input connector are in a grey outlined area at the lower left of the panel. The remainder of the front panel contains Sweep circuit controls, switches, and adjustments.

A brief description of the function or operation of the front panel controls follows. More detailed information is given under General Operating Information.

SWEEP Controls and Connectors

TIME POSITION and FINE controls Two concentric controls providing coarse or fine control of the time relationship between triggering and the start of the CRT display. The TIME POSITION control permits continuously variable adjustment of delay in starting the display, up to the amount indicated in the TIME POS RNG window. The FINE control has only about 1% of the effect of the TIME POSITION control, and is particularly useful at TIME/DIV settings of high magnification.

RANDOM Pushbutton Selects Random Sampling mode of operation. Does not function in the three slowest (real-time) Sweep Ranges. Permits the display of the input signal prior to the triggering point without use of a delay line or pretrigger.

SEQUENTIAL Pushbutton Selects Sequential Sampling mode of operation. Does not function in the three slowest (real-time) Sweep Ranges. Permits equivalent-time operation at lower trigger repetition rates than does the Random mode.

SWEEP RANGE Switch Selects the range of operation of the TIME/DIV switch and indicates the corresponding time position range (TIME POS RNG). Permits a choice of any of nine TIME/DIV settings at each of the seven positions of the SWEEP RANGE SWITCH. The SWEEP RANGE con-

rol is concentric with the TIME/DIV and VAR (CAL IN) controls.

TIME/DIV Switch Selects calibrated time/division settings from 10 ps/div to 5 ms/div, in 27 steps, in a 1, 2, 5 sequence.

VARIABLE (CAL IN) Control When in the out position, rotating the VARIABLE control permits changing time per division from the calibrated value selected by the TIME/DIV switch. Push knob in and release to activate; the knob moves outward from the TIME/DIV control when activated.

TIME POS RNG Time-positioning ranges from 50 ns to 50 ms in seven decades are available. Time-positioning range available and indicated in the TIME POS RNG window is determined by the setting of the SWEEP RANGE switch. The indicated range is always ten times the slowest time/div of the Sweep Range selected.

SWEEP CAL Control A front panel screwdriver adjustment that adjusts horizontal gain to match the oscilloscope deflection factor. Adjusted when switching 7T11 from one oscilloscope to another.

POSITION Control A front panel screwdriver adjustment to position the display horizontally on the CRT of the oscilloscope.

SWEEP OUT Jack Pin jack providing an output voltage proportional to the display. With an output resistance of 10 k Ω an output of one volt for each division of display is provided.

SCAN Controls

Variable SCAN Control Provides an internal voltage for adjusting the scan rate in the REP mode, or for manually scanning the display in the MAN mode. Also used to set the horizontal gain using the SWEEP CAL control. Serves as a variable attenuator in the EXTERNAL INPUT mode.

REP Pushbutton Provides repetitive scanning of the display. Scan rate is adjusted using the variable SCAN control. It does

Operating Instructions—7T11

REP Pushbutton (cont)	not function in the three slowest (real-time) Sweep Ranges.
MAN Pushbutton	Provides manual operation of the scan function using the variable SCAN control. Does not function in the three slowest (real-time) Sweep Ranges.
EXT INPUT Pushbutton	Allows scanning the display using an external signal. In this mode of operation, the variable SCAN control serves as a variable attenuator.
External Input Jack	A pin jack (input resistance of 100 k Ω) providing an input facility for externally scanning the display. With the SCAN control fully CW a one volt input is needed for each division of display.

Triggering Controls

SLOPE (+), (-) Pushbuttons	Selects the positive-going (+) or negative-going (-) slope of the triggering signal.
TRIG LEVEL Control	Determines the amplitude level on the triggering waveform where triggering is to occur. Also serves as a fine synchronizing adjustment in the HF SYNC mode. The TRIG LEVEL control is concentric with the STABILITY control.
STABILITY Control	Adjusts the width of the trigger hysteresis. Also serves as a coarse sync adjustment in the HF SYNC mode.
TRIG AMP Pushbuttons	Select X1 or X10 amplification of the trigger signal.
INT Pushbutton	Selects internal triggering for operation with sampling heads that provide a trigger pickoff.
EXT 50 Ω Pushbutton	Selects external, DC-coupled, low-impedance trigger operation at the common trigger input connector.
EXT 1 M Ω Pushbutton	Selects external, DC-coupled, high-impedance trigger operation at the common trigger input connector.
EXT HF SYNC Pushbutton	Selects external, AC-coupled (1 M Ω to ground) HF SYNC operation. In this mode of trigger operation, the STABILITY and TRIG LEVEL

controls are used to obtain a stable display with trigger signals above approximately 1 GHz.

EXT TRIG INPUT Connector

A 3 mm connector located near the lower right portion of the front panel and used for introducing an external triggering signal to the 7T11.

PULSE OUT Connector

A BSM connector providing a positive pulse corresponding to the firing of the trigger circuit.

FIRST-TIME OPERATION

General

When shipped from the factory, the 7T11 Sampling Sweep Unit has been calibrated to meet the specifications listed in Section 1 and is ready to be used with a Tektronix 7000-series oscilloscope.

The following steps demonstrate the basic operation of the controls of the 7T11. It is recommended that this procedure be followed completely for familiarization with the instrument. Operation of the oscilloscope and vertical plug-in unit (Sampling Unit) is described in the instruction manuals for these units. The equipment set-up used during the following procedure is shown in Fig. 2-3.

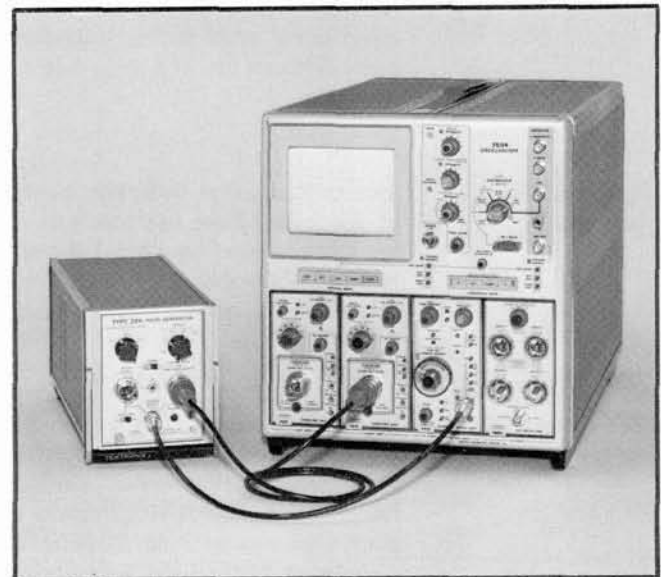

Fig. 2-3. Equipment setup used during first time operation.

Setup Information

1. Insert a 7S11 Sampling Unit with a Type S-2 Sampling Head in the left vertical compartment of the 7504 oscilloscope.

NOTE

Any Tektronix 7000-series oscilloscope may be substituted for the 7504. Only the plug-ins listed in steps 2 and 3 are actually needed to perform this First-Time Operation but the use of Plug-ins listed in steps 1 and 4 is illustrated later in this section under the heading of General Operating Information.

2. Insert a 7S11 Sampling Unit with a Type S-1 Sampling Head in the right vertical compartment of the oscilloscope.

3. Insert a 7T11 Sampling Sweep Unit in the "A" horizontal plug-in compartment.

4. Insert a 7M11 50 Ω Delay Line in the B horizontal compartment. This plug-in may be used on the bench alongside of the oscilloscope instead of in the plug-in compartment since the only connections required are to the 7M11 front panel.

5. Set the controls as follows:

	7504	
Vertical Mode		Right
Horizontal Mode		A
Readout		Midposition
Control Illum		High
Intensity		Fully CCW
	7S11	
+ UP pushbutton		Pushed in
DC Offset control		Midposition
mVolt/Div switch		200
Normal pushbutton		Pushed in
	7T11	
TIME POSITION controls		Fully clockwise
SEQUENTIAL pushbutton		Pushed in
TIME POS RNG		5 μs
TIME/DIV		.5 μs/Div (500 ns readout)
VARIABLE (CAL IN) control		Pushed in
SCAN control		Midposition

7T11 (cont)

REP pushbutton	Pushed in
STABILITY control	Fully CCW
TRIG LEVEL control	Midposition
SLOPE pushbutton	(+) pushed in
TRIG AMP pushbutton	X10 pushed in
EXT 50 Ω triggering pushbutton	Pushed in

Type 284

Square Wave Amplitude	1.0 V position
Period	1 μs
Mode	Square Wave or Sine Wave Output
Lead Time	75 ns

NOTE

Type 284 instruments having serial numbers prior to SN B030236 require installation of Field Modification Kit, Tektronix Part No. 040-0487-00 in order to obtain a 75 ns trigger lead time.

Turn on power and allow the equipment to warmup for 5 minutes. Connect a 50 Ω coaxial cable having a 5 ns signal delay and GR874 connectors between the Type 284 Square Wave or Sine Wave Output connector and the input connector of the Type S-1 Sampling Head.

Connect the Trigger Output connector of the Type 284 to the 7T11 TRIG INPUT connector through a 50 Ω coaxial cable with a 2 ns signal delay and BNC connectors. A 3 mm male to BNC adapter (Tektronix Part No. 015-1018-00), included as a standard accessory with the 7T11, must be connected to the 3 mm TRIG INPUT connector on the 7T11.

Adjust the Focus, Intensity, and DC Offset controls for a display similar to that shown in Fig. 2-4. Rotate the SCAN control slowly from one extreme to the other and note that clockwise rotation increases the scan rate and reduces the dot density. Return the SCAN control to its midposition. Push in and release the VARIABLE (CAL IN) control and note that the less-than symbol (<) is displayed on the CRT just to the left of the 500 ns readout. Rotate the VARIABLE control from its fully CCW position and note that clockwise rotation results in an increasing magnification of the display or a reduction in actual time per division. Return the VARIABLE control to its fully CCW position and push it into the CAL position.

Adjusting SWEEP CAL

Push the MAN SCAN pushbutton in and observe that the pushbutton lights. Turn the SCAN control fully

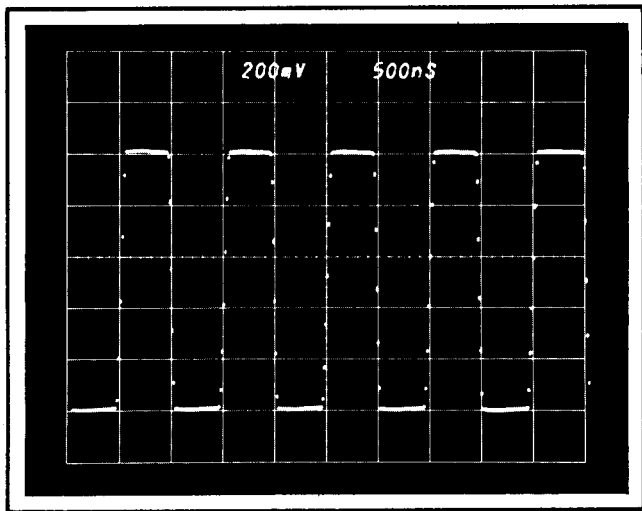

Fig. 2-4. Sequential equivalent-time sampling display of 1 μ s, 1 V square-wave output of the Type 284.

counterclockwise. A spot should be observed at the left edge of the graticule. Rotate the SCAN control to its fully CW position. The spot should have moved exactly ten divisions to the right of its previous position. Use a small screwdriver to adjust the SWEEP CAL on the 7T11 front panel for ten divisions of movement when the SCAN control is turned from one extreme to the other. This adjustment should be made whenever the plug-in is switched to a different oscilloscope. This adjustment should be checked occasionally even if the plug-in remains with the same oscilloscope.

The POSITION control on the 7T11 front panel is adjusted with a screwdriver so the spot appears at the left graticule edge with the SCAN control fully CCW. Return the SCAN to repetitive by pushing the REP pushbutton and set the SCAN control to its approximate midposition.

Observing a Fast-Rise Pulse

One method of observing the leading edge of a fast-rise pulse is to use a slow enough sweep so that the pulse following the one producing triggering is displayed. Either Internal or External triggering can be used. By using the TIME POSITION control to move the displayed pulse near to the left graticule edge and turning the TIME/DIV switch clockwise to a setting providing high magnification, satisfactory results can be obtained if the input signal has the proper characteristics. The input signal repetition rate must be constant; otherwise jitter or a meaningless display will result. Also, if the interval between pulses is excessively long compared to the time interval of interest, a suitable combination of TIME POS RNG and TIME/DIV will be unattainable.

Two other methods of seeing before the triggering point, without the limitations of the method above, are available

during Sequential equivalent-time sampling. These methods provide a means of getting the trace started before the vertical signal reaches the CRT vertical deflection plates. These methods are as follows:

(a) The path of the vertical signal that must travel from the signal source to the Sampling Head input can be lengthened while the distance traveled by the triggering signal is kept as short as possible. This method, using a 7M11 50 Ω Delay Line, is discussed later in this section under the heading of General Operating Information.

(b) The method used during First-Time Operation is to use a signal source, such as the Type 284, that provides a signal for triggering slightly before it delivers an output pulse to the Sampling Head input. A pretrigger Lead Time of either 5 ns or 75 ns can be selected at the Type 284 front panel.

Change the settings on the following controls:

	Type 284
Mode switch	PULSE OUTPUT
	7S11
mV/Div	50 mV/Div
	7T11
TIME POS RNG	50 ns
TIME/DIV	5 ns

Disconnect the coaxial cable from the Type 284 Square Wave or Sine Wave Output connector and reconnect it to the Type 284 Pulse Output connector. Check that the read-out displayed on the CRT is 5 ns, and that the Type 284 Lead Time switch is set to the 75 ns position. Vertically center the display using the 7S11 DC Offset control.

With the TIME POSITION controls fully CW the leading edge of the output pulse of the Type 284 should be visible as shown in the typical display of Fig. 2-5A. Fig. 2-5A shows that although the Type 284 is supplying a trigger 75 ns before the Pulse Output signal, the signal is displayed only 7 or 8 ns after the trace starts. If the 3 ns difference in travel time through the coaxial cables delivering the vertical input and trigger input signals is considered, the actual effective trigger lead time is approximately 78 ns. In Fig. 2-5A the lead time is only 7 or 8 ns more than the minimum required to display the input signal leading edge. The location of the pulse in Fig. 2-5A is typical. Factors that will affect the horizontal position, of the pulse leading edge with respect to the start of the sweep are: slight differences in the Lead Time provided by different Type 284's, differ-

ences in the delay within different 7T11's, and the setting of the TRIG LEVEL control.

Rotate the TIME POSITION and FINE controls slowly CCW and notice that they increase delay and thereby cause the displayed pulse to move to the left. Using the TIME POSITION controls, set the pulse leading edge one division from the left edge of the graticule as shown in Fig. 2-5B. Disconnect the coaxial cable from the input of the Type S-1 Sampling Head and insert an additional 5 ns length of coaxial cable between the cable just disconnected and the Sampling Head input. The additional 5 ns of delay inserted in the path of the input signal will cause the pulse to move one division (5 ns) to the right as shown in Fig. 2-5C. This provides a means of providing additional lead time and also a means of determining the delay caused by a length of cable.

Turn the TIME/DIV switch to the .2 ns/Div position (200 ps readout on CRT) and use the TIME POSITION control to horizontally position the pulse leading edge to graticule center. Note that the FINE control has more effect in moving the display as the TIME/DIV control is set to its more clockwise positions.

Specified risetime of the Type S-1 (≤ 350 ps) is too slow to accurately measure the Type 284 output pulse risetime (≤ 70 ps). If this risetime measurement is desired, use a Type S-4 Sampling Head which has a risetime of less than 25 ps. Consult the instruction manual for this sampling head for more information on measuring fast-rise signals.

Turn the oscilloscope Intensity control fully counter-clockwise and push in the HF SYNC pushbutton. The HF SYNC pushbutton will light and the X10 TRIG AMP and (+) SLOPE lights will go out. When using HF SYNC, the triggering slope and the TRIG AMP controls have no effect.

Rotate the SWEEP RANGE control fully CW to where the TIME POS RNG window shows 50 ms. Real-Time sampling is provided at this setting of the SWEEP RANGE control as well as at the next two faster SWEEP RANGE settings. The SEQ or RANDOM pushbuttons will not light on these three Real-Time ranges. The SCAN controls are also inoperative on Real-Time ranges and these pushbuttons will not light.

GENERAL OPERATING INFORMATION

Triggering Considerations

When using Sequential equivalent-time sampling to observe a fast risetime pulse, a pretrigger or external delay

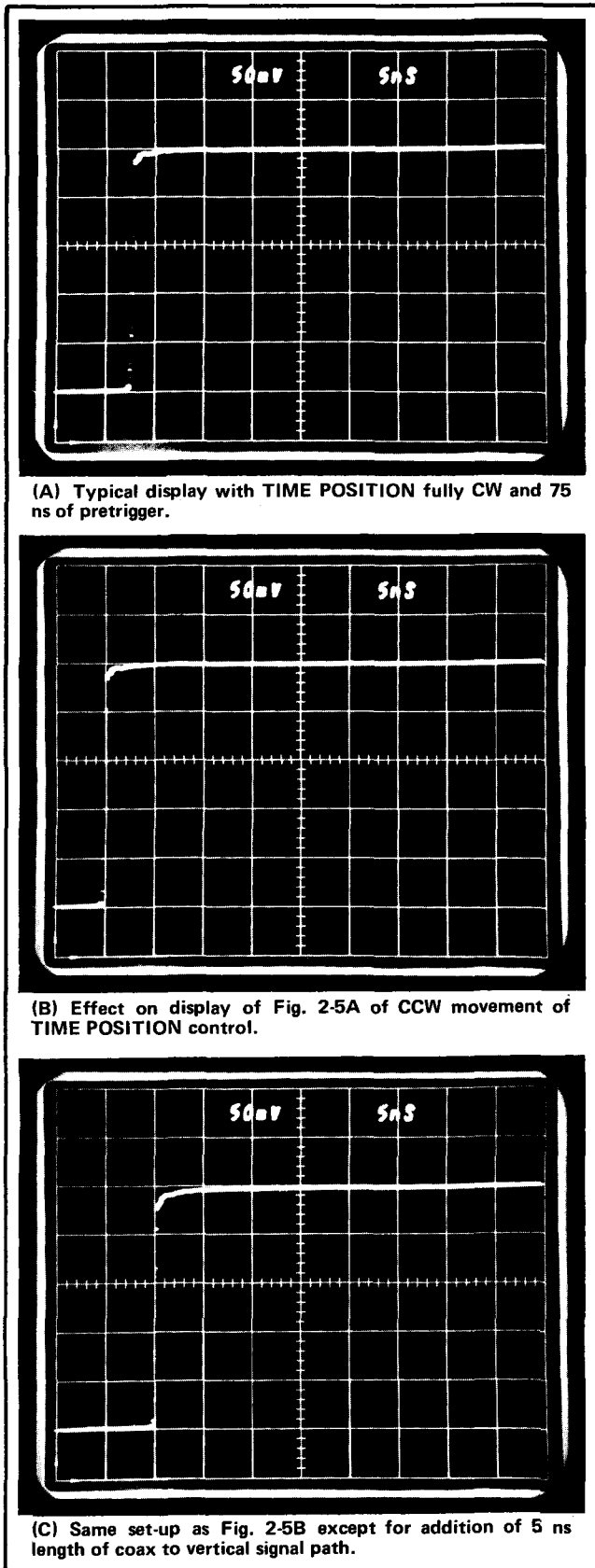

Fig. 2-5. Observing the leading edge of a fast-rise pulse using the SEQUENTIAL equivalent-time mode.

Operating Instructions—7T11

line is normally required. Use of a 7M11 Delay Line is discussed later in this section.

Internal triggering or any one of three modes of External triggering can be selected by using four pushbuttons on the 7T11 front panel. Triggering signals are not routed through the pushbuttons. The front panel pushbuttons control reed relays located in the 50 Ω path provided for triggering signals. (Triggering controls on the oscilloscope mainframe have no controlling effect.) This triggering system reduces pickup of unwanted noise and loss of high frequency components of the trigger signals.

Internal triggering of the 7T11 from the signal applied to either vertical channel is available. Pushing in the INT pushbutton on the 7T11 will cause this button to light. The INT pushbutton lights on the 7S11 that is supplying the triggering signal.

Triggering Rate

Triggering rate is limited by holdoff. The minimum trigger holdoff time at each of the seven available time positioning ranges (indicated in the TIME POS RNG window) is shown in Table 2-1. The TIME POS RNG is determined by the setting of the SWEEP RANGE control.

TABLE 2-1
Minimum Trigger Holdoff

Indication in TIME POS RNG window		Minimum Trigger Holdoff Time
R T E I M E P O S I T I O N	50 ms	at least 2 ms
	5 ms	at least 2 ms
	500 μ s	at least 2 ms
E X T E R N A L	50 μ s	at least 220 μ s
	5 μ s	at least 25 μ s
	500 ns	at least 25 μ s
	50 ns	at least 25 μ s

The maximum rate at which triggers can be recognized is the reciprocal of the minimum trigger holdoff time shown in Table 2-1. In Real-Time operation, delay introduced using the TIME POSITION controls and the duration of the time window (ten times the TIME/DIV setting) must be added to the minimum values shown in Table 2-1. The Sweep Range providing the greatest time-positioning range and the slowest real-time sweep can therefore cause the

greatest variation from the minimum holdoff time shown in Table 2-1.

In Random mode the triggering point, T_0 , is displayed close to the center line of the CRT with the Time Position control fully CW and the Time/Div switch fully CCW. The lowest **allowable** triggering rate for the 7T11 in Random mode is 100 Hz; this applies to all equivalent-time Sweep Ranges. The lowest **usable** triggering rate for any particular Time/Div setting depends on the minimum dot density that the operator is willing to use. In Random mode, the sampling event referenced to a particular trigger is timed from the preceding trigger. If the trigger rate is high and uniform, then the sampling event prediction is more accurate and the samples occur where they are programmed to occur. As the rate goes down, the ability to predict when the next trigger will occur diminishes, and the samples begin to happen in a more **random** fashion. When the trigger rate slows (or the period jitter increases) sufficiently, the predictability is reduced to the point where the sampling distribution falls over the whole screen. In this case, best dot density is obtained by selecting MAN SCAN and placing the center of the dot distribution at mid-screen.

SWEEP RANGE Control

Sweep rate of the display is controlled by three concentric knobs. The outer, larger knob (SWEEP RANGE control) controls the sweep range over which the TIME/DIV knob may be switched. The window on the left of the TIME/DIV knob displays the TIME POS RNG (time positioning range); this number is always 10 times the slowest available TIME/DIV of a particular SWEEP RANGE setting. The selected TIME/DIV is displayed on the CRT by the oscilloscope if the oscilloscope is provided with readout capability. The VARIABLE control can provide a minimum of 2.5 to 1 magnification at any TIME/DIV setting. At the three slowest SWEEP RANGE settings, sampling is in Real-Time while the remaining four positions provide equivalent-time (random or sequential) sampling.

The TIME/DIV settings available at each position of the SWEEP RANGE control are shown in Table 2-2. Turning the SWEEP RANGE control fully CW selects the slowest setting of the SWEEP RANGE control. Thus the fully CW position has been designated as SWEEP RANGE position 1 in Table 2-2. Reading horizontally to the right from the fully CW (designated as position 1 in Table 2-2) SWEEP RANGE position shows, under the TIME POS RNG column, a value of 50 ms. Continuing to the right shows that nine TIME/DIV settings, from 5 ms/div at X1 magnification to 10 μ s/div at X500 magnification, are available. As the SWEEP RANGE control is rotated CCW increasingly faster Sweep Ranges are selected.

It should be noted that the nine TIME/DIV settings available at each of the seven positions of the SWEEP

TABLE 2-2

	Sweep Range Position ↓	TIME POS RNG ↓	TIME/DIV and Magnification									
			← CCW	X1	X2.5	X5	X10	X25	X50	X100	X250	X500
R E A L T I M E	Fully CW 1	50 ms	5 ms	2 ms	1 ms	.5 ms	.2 ms	.1 ms	50 μs	20 μs	10 μs	
	2	5 ms	.5 ms	.2 ms	.1 ms	50 μs	20 μs	10 μs	5 μs	2 μs	1 μs	
	3	.5 ms	50 μs	20 μs	10 μs	5 μs	2 μs	1 μs	.5 μs	.2 μs	.1 μs	
E Q U I V	4	50 μs	5 μs	2 μs	1 μs	.5 μs	.2 μs	.1 μs	50 ns	20 ns	10 ns	
	5	5 μs	.5 μs	.2 μs	.1 μs	50 ns	20 ns	10 ns	5 ns	2 ns	1 ns	
	6	.5 μs	50 ns	20 ns	10 ns	5 ns	2 ns	1 ns	.5 ns	.2 ns	.1 ns	
	Fully CCW 7	50 ns	5 ns	2 ns	1 ns	.5 ns	.2 ns	.1 ns	50 ps	20 ps	10 ps	

RANGE control provide a total of 63 combinations. Only 27 different TIME/DIV settings are available, however, since most TIME/DIV settings are available at two or three settings of the SWEEP RANGE control. For example, TIME/DIV settings of 50 μs, 20 μs and 10 μs are shown in Table 2-2 to be available at all three Real-Time positions of the SWEEP RANGE control. If a TIME/DIV setting of 20 μs/div is required, any of the three Real-Time Sweep Ranges can be used; however, more time-positioning range (TIME POS RNG) is provided at the slower SWEEP RANGE settings.

TIME/DIV Settings

A total of 27 different sweep rates are available ranging from 5 ms/div to 10 ps/div in a 5, 2, 1 sequence (see Table 2-2). On the slowest SWEEP RANGE position a total of nine TIME/DIV settings (5 ms/div to 10 μs/div) are available. Each of the six other positions of the SWEEP RANGE also offer a choice of nine TIME/DIV settings.

The nine TIME/DIV control settings determine the amount of display magnification. See Fig. 2-6. On all Sweep Ranges the display magnification changes from X1 to X500 in a 1, 2.5, 5 sequence as the selected TIME/DIV setting is changed from the slowest available rate to the fastest.

TIME POSITION Control

The TIME POSITION control permits delaying the display or time window start by an amount up to the value indicated in the TIME POS RNG window. Delay introduced by this control is removed by turning the control fully clockwise. The FINE control serves the same purpose but has only about 1% as much effect as the TIME POSITION control.

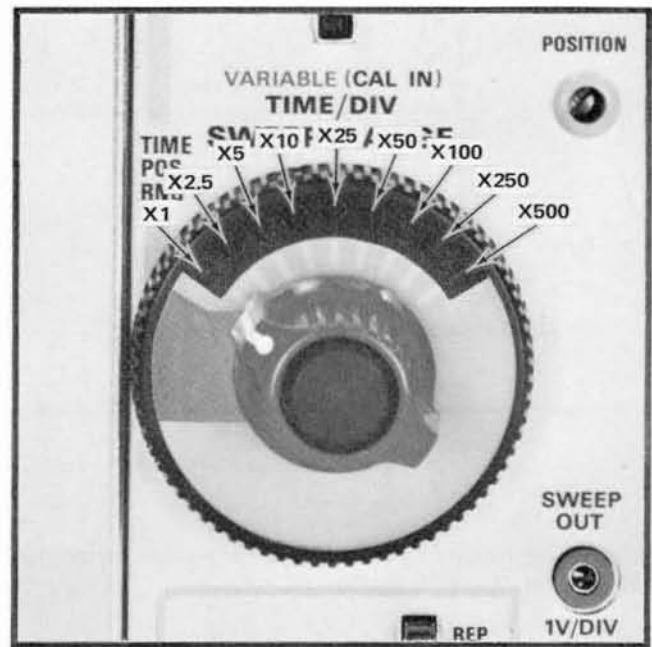

Fig. 2-6. Magnification depends upon the position, within the control window, of the selected TIME/DIV setting.

Fig. 2-7A and 2-7B show that the duration of the display or time window is ten times the selected TIME/DIV setting. At the SWEEP RANGE setting specified in Fig. 2-7 the TIME POS RNG (time positioning range) is 50 μs. During SEQUENTIAL operation and with the TIME POSITION control fully CW (clockwise) the start of the display or time window occurs just after trigger recognition (time T₀).

During RANDOM equivalent-time sampling a lead-time of approximately 1/2 TPR (time-positioning range) is provided. Trigger recognition (T₀) will therefore occur at about 25 μs with the SWEEP RANGE setting represented in Fig. 2-7. During Random sampling the 50 μs of time-

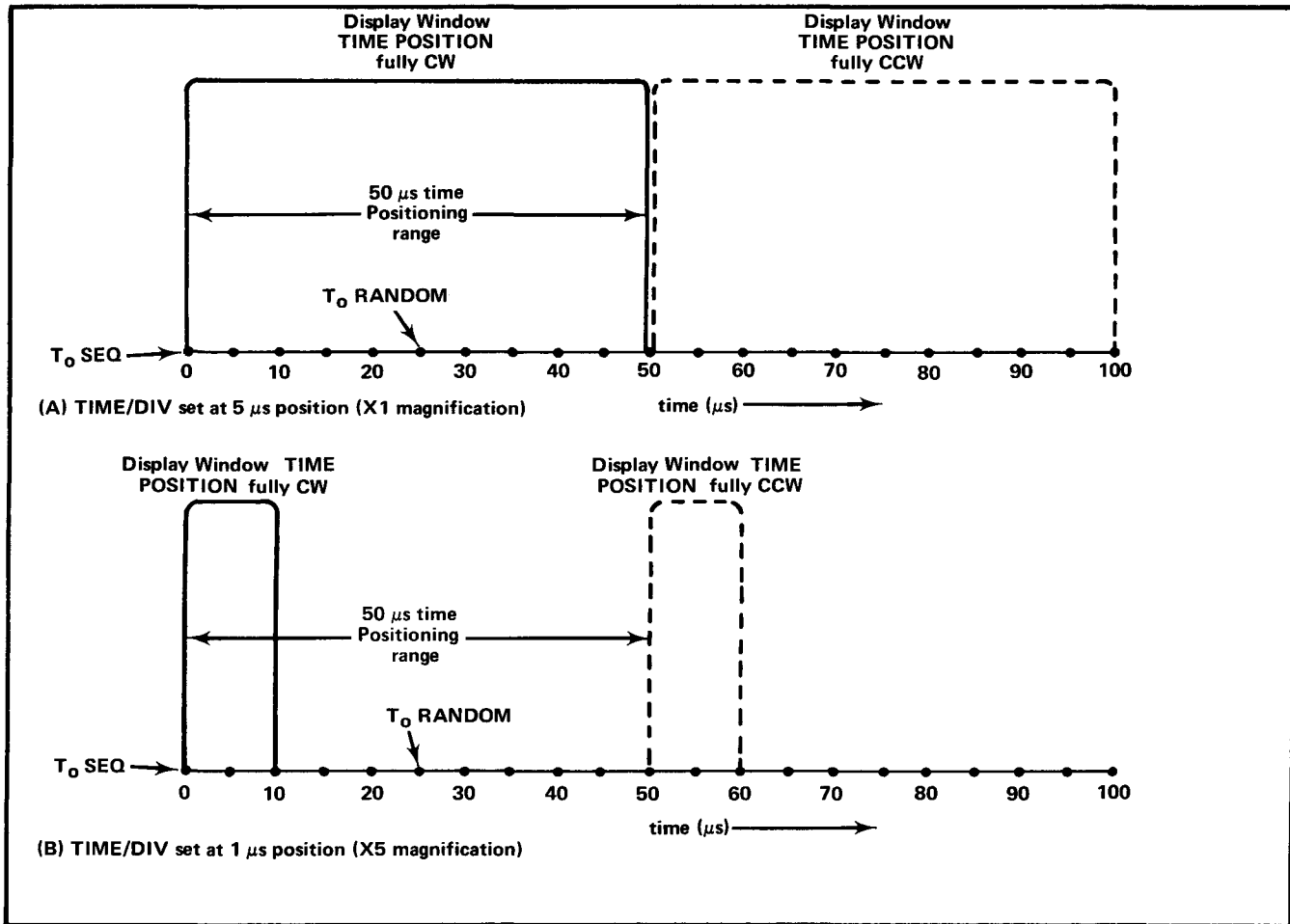

Fig. 2-7. Effect of TIME POSITION control (SWEEP RANGE at 5 $\mu\text{s}/\text{div}$ to 10 ns/div position).

positioning range shown in Fig. 2-7B permits seeing from 25 μs before T_0 to 35 μs after T_0 .

The TIME POSITION control also works during Real-Time operation. The smaller the delay from T_0 the brighter the display.

SCAN Control

During Real-Time operation the SCAN control and pushbuttons are inoperative and the pushbutton lights go out.

The SCAN control serves three functions, selected by the pushbuttons. Pushing in the REP pushbutton results in a free-running sweep, the scan rate increasing with CW rotation of the SCAN control. Selecting MAN gives a single point of time on the screen, or centers the distribution of samples around a point on the screen. This control also provides a means of setting the SWEEP CAL adjustment for 10 centimeters of scan using a built-in zener diode as a

voltage reference. EXT input allows the 7T11 to be driven from other sweep sources, with the SCAN control acting as an attenuator. Single Sweep operation has not been provided, but is possible by EXT INPUT drive from a Real-Time Sweep plug-in.

As mentioned above, turning the SCAN control clockwise increases the scan rate. At faster scan rates the horizontal spacing between dots is increased. Fewer samples per scan are taken, resulting in a decrease in dot density. Counterclockwise rotation of the SCAN control has the opposite effect; scan rate decreases and dot density is increased.

TRIG LEVEL and STABILITY Controls

These controls provide control of the Schmitt trigger circuit as in a conventional oscilloscope. Rotation clockwise from a central position picks up triggering on a more and more positive portion of the wave; counterclockwise from midrange picks up triggering from more and more negative

portions of the triggering signal. The stability control setting is not critical for most triggering situations. A CCW rotation sets the Schmitt hysteresis at about 50 mV when driven by an unamplified waveform. Rotation to CW causes the Schmitt hysteresis bands to overlap, providing free-run operation for trigger level settings near the center of the range. This allows synchronization to signals from 50 MHz to around 1 GHz.

Trigger Pushbutton Switches

The SLOPE pushbuttons permit selection of triggering on either the (+) or (–) slope of the triggering signal.

A trigger amplifier is provided. Pushing in the X10 pushbutton provides amplification of the input trigger signal. This amplifier is switched out when the X1 pushbutton is pushed in. When the unit is switched to HF SYNC, the SLOPE and TRIG AMP switch lights go out because the circuits they control become inoperative.

The remaining four trigger pushbuttons allow the user to select Internal or 3 modes of External triggering, 50 Ω , 1 megohm, or HF Sync: the most often used for high speed pulse work is the 50 Ω mode. Both the 50 Ω and 1 M Ω positions are DC coupled. In HF SYNC, the signal is routed through a high pass filter to a 200 MHz oscillator, allowing synchronism up to X band signals. The STABILITY control is here used as a coarse sync control; the TRIG LEVEL control is used for fine sync adjustments.

PULSE OUT Connector

This connector provides a positive-going, 0.5 volt pulse into 50 Ω that is useful for triggering external circuits for closed loop testing. This pulse occurs shortly after the Trigger recognition point (time T_0).

Use of Real-Time Mode

In general, Real-Time sampling is used to observe low frequency signals while equivalent-time sampling is used to observe the higher frequency signals. Since the faster real-time TIME/DIV settings are also available using equivalent-time sampling, at these TIME/DIV settings, the mode providing the best display is used.

The Real-Time sampling display of the 0.2 V, 1 kHz square-wave output of the 7000-series oscilloscopes calibrator is shown in Fig. 2-8. Few, if any, dots representing samples taken, are visible during the relatively fast rise and fall time of this square wave. During Real-Time operation the dot density, or samples per division of display, is affected by the TIME/DIV setting. Faster TIME/DIV settings result in a fewer number of samples per division of display.

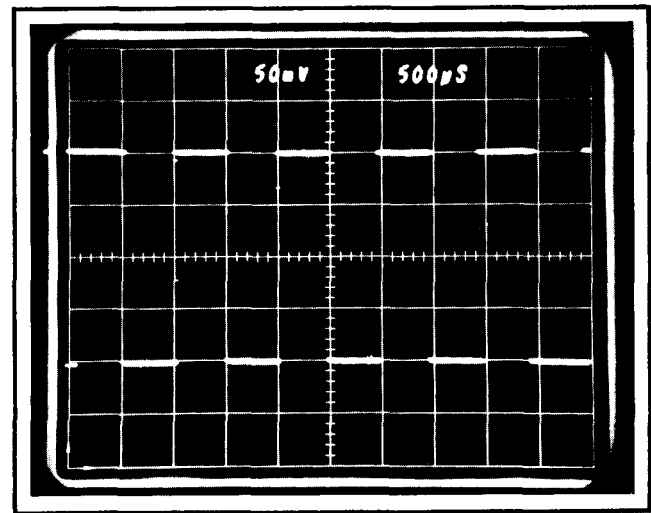

Fig. 2-8. Real-time sampling display of the 0.2 V, 1 kHz output of the 7000-series oscilloscopes calibrator.

Use of the 7M11 Delay Line

As mentioned during the discussion of First-Time Operation the 7M11 Delay Line may be used instead of a pretrigger to get the sweep started before the vertical signal reaches the CRT.

Connect the Trigger Output of the 7M11 through a 50 Ω coaxial cable to the TRIG INPUT connector on the 7T11. Set the 7M11 Trigger Selector switch to 1.

The 7M11 50 Ω Delay Line is connected between the signal source and the Sampling Head input.

1. Connect the signal to be observed to INPUT 1 of the 7M11.
2. Connect OUTPUT 1 of the 7M11 to the input of the Sampling Head.

The effect of the 7M11 on the input signal must be considered. The actual signal amplitude is twice the value displayed due to the 2X attenuation of the 7M11. Signal amplitude at the 7M11 Trigger Output connector is approximately one-fifth the amplitude of the signal applied to INPUT 1 of the 7M11. The specified risetime of the 7M11 must be considered when measuring very fast-rise signals.

The delay line method is useful when a pretrigger source is not available. For further information on use of a delay line consult your 7M11 instruction manual.

Random Sampling

Use of the Random mode of sampling provides a sweep that starts before the triggering point on the signal, without the need for a pretrigger or delay line. The loss of input signal amplitude and increase in system risetime resulting

from use of the delay line is eliminated in the Random mode. The minimum triggering rate, however, is about 100 Hz during Random operation instead of the 10 Hz rate permissible during Sequential operation. Either Internal or External triggering may be used.

SECTION 3

CIRCUIT DESCRIPTION

Change information, if any, affecting this section will be found at the rear of the manual.

This section is divided into two parts: Theory of Operation, and Circuit Analysis. The Theory of Operation portion describes the purpose and relationship of the various 7T11 circuits. The effect of the 7T11 operating controls on each of the three modes of sampling is also explained. The three sampling modes are discussed in the following order: Real Time, Sequential Equivalent Time, and Random Equivalent Time.

Before reading this section, go back and read the Operating Instructions (Section 2) of this manual and get familiar with the 7T11 controls. If the reader is not thoroughly familiar with Sampling Techniques, read the section entitled "Tektronix Basic Sampling Principles" in your Sampling Unit instruction manual.

The Circuit Analysis portion of this section provides a detailed discussion of the 7T11 circuits shown on schematic diagrams at the rear of this manual. The purpose of the circuits and of many circuit components shown on these schematics is explained in the Circuit Analysis.

THEORY OF OPERATION REAL TIME SAMPLING

General

In Fig. 3-1, the Trigger, TTH, and Horizontal Amplifier serve the same purpose as the Trigger, Sweep Generator, and Horizontal Amplifier circuits in a conventional horizontal sweep unit. The function of these blocks will be discussed first.

The 7T11 Trigger circuit permits triggering at any desired portion of an input signal. A suitable trigger from an internal or external source results in an output from the trigger circuit if the trigger circuit is in a ready to fire condition. The time at which the trigger circuit delivers an output is referred to as trigger recognition and is designated as T_O in this manual. Once the trigger circuit fires, starting the TTH ramp, no further incoming triggers will be recognized until the sweep ends and the recovery time has elapsed.

A selected portion of the negative-going output of the TTH ramp is amplified in the Horizontal Amplifier by an

amount dependent upon the selected TIME/DIV setting. The output of the Horizontal Amplifier is fed to the Horizontal Memory circuit. The Horizontal Memory circuit provides X2 amplification of the Horizontal Amplifier output. The output ramp of the Horizontal Memory differs from the usual horizontal deflection signal in that it runs down in a series of voltage steps.

The output of the Horizontal Amplifier is connected to the input of the Horizontal Memory only when the Memory Gate is open. The Memory Gate is controlled by the Real-Time Multivibrator, which is controlled by the Real-Time Oscillator in the vertical plug-in unit.

A ramp amplitude of 10 volts is required at the output of the Horizontal Memory to produce 10 divisions of horizontal deflection on the CRT. The 10-volt ramp at the Horizontal Memory output is fed to the Output Amplifier. The Output Amplifier prevents loading of the Horizontal Memory circuit and changes the single-ended output of the Horizontal Memory to the push-pull horizontal drive signal required by the 7000 series oscilloscope. The 10-volt output of the Output Amplifier is delivered to a Horizontal Interface board in the oscilloscope, and then to the CRT horizontal deflection plates. If either output of the Output Amplifier exceeds +5 volts an overrun blanking circuit (now shown in Fig. 3-4) is enabled, preventing display of the overrun portion of the sweep.

The 10-volt change at the Horizontal Memory output must occur in 5 ms in order for timing to be correct at the TIME/DIV setting shown in Fig. 3-1. Fig. 3-2 shows that the TTH output voltage changes only 5 volts in 5 ms at the selected position of the SWEEP RANGE control. With the SWEEP RANGE and TIME/DIV settings given in Fig. 3-1, the Horizontal Amplifier has a gain of 1. The fixed X2 gain of the Horizontal Memory provides the required rate of change of voltage. Since the TTH continues to run negative after 5 ms from ramp start as shown in Fig. 3-2, the Horizontal Amplifier output continues to run positive. This positive run is stopped by a reset circuit (not shown on Fig. 3-1) when the Horizontal Amplifier Output voltage reaches approximately 5.2 volts.

Fig. 3-2 shows that the rate of change of the ramp output of the Horizontal Memory is twice that of the ramp

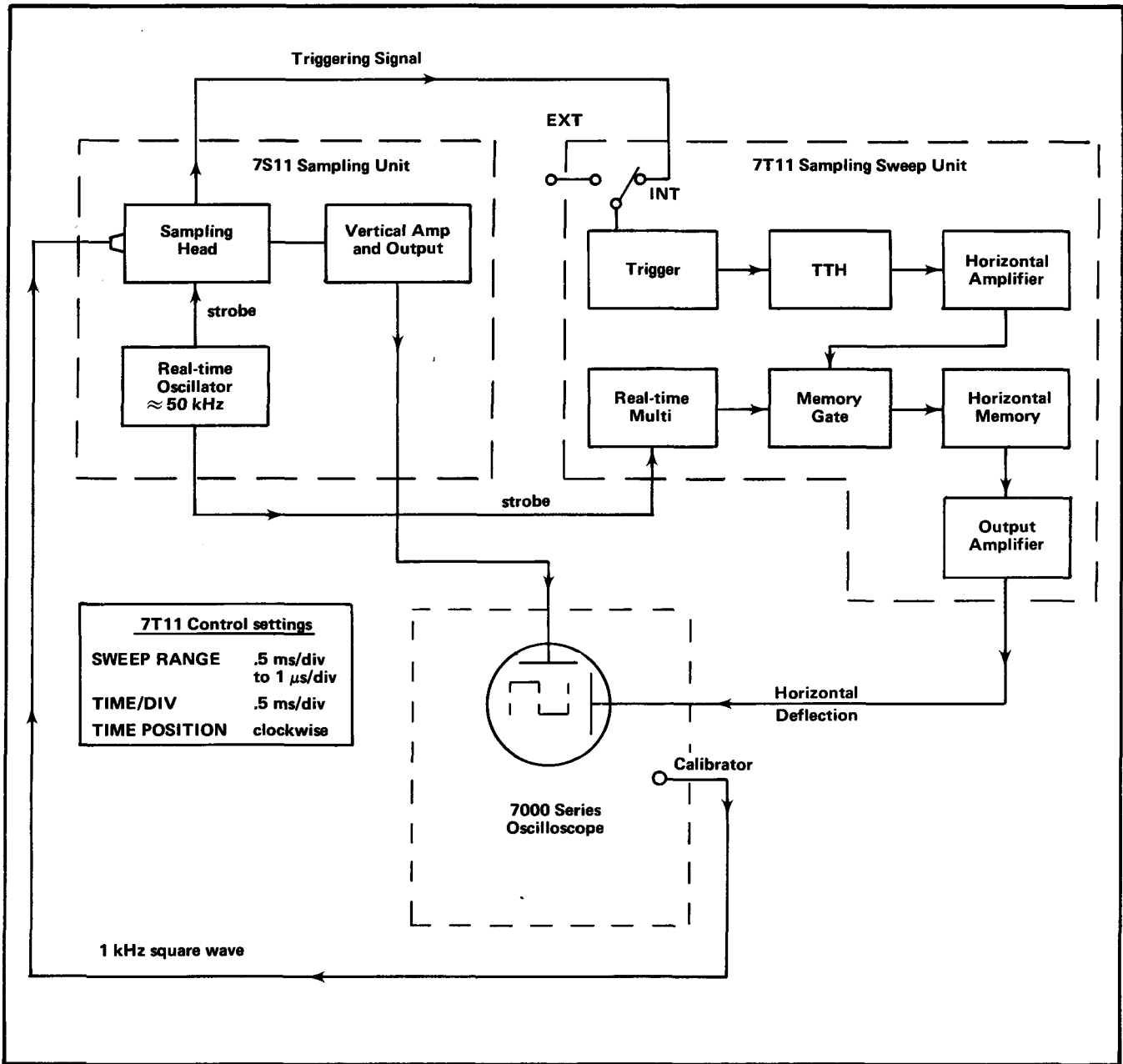

Fig. 3-1. Simplified block diagram of a sampling system using the 7T11 as a Real-time Sampling Sweep Unit.

output of the Horizontal Amplifier. In addition to providing X2 gain, the Horizontal Memory inverts the applied signal and shifts its starting level from 0 volts to +5 volts. The output from the memory is not the perfect linear ramp it appears to be in Fig. 3-2D. The voltage change from +5 volts to -5 volts is accomplished in 250 steps of 40 millivolts each.

Staircase Ramp Output of the Horizontal Memory

Although the TTH produces a linear ramp, just as the time base generator in a conventional oscilloscope, the

ramp leaving the memory (see Fig. 3-3D) is a staircase. This is due to the sampling, at regular intervals, of the Horizontal Amplifier output by the Horizontal Memory. The output of the Horizontal Amplifier is connected to the input of the Horizontal Memory only when a memory pulse is applied to the Memory Gate. The action of the Memory Gate changes the linear ramp at the Horizontal Amplifier output to the staircase ramp appearing at the output of the memory. A 3 μs duration gating pulse is applied from the Real Time Multivibrator to the Memory Gate at intervals of 20 μs. The 50 kHz Real Time Oscillator, shown in Fig. 3-1, controls the period of the Real Time Multivibrator and

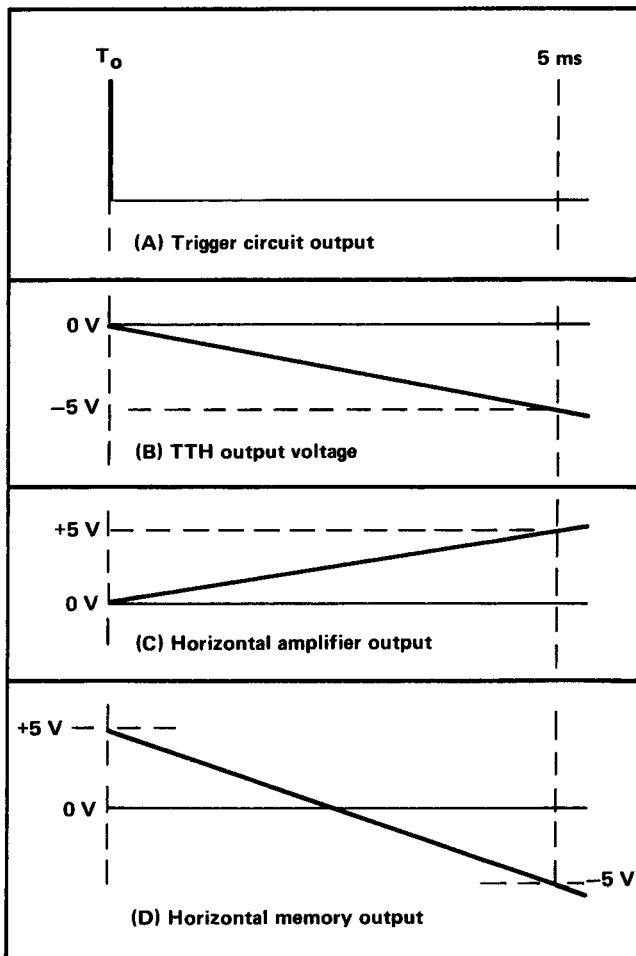

Fig. 3-2. Circuit waveforms at control settings shown in Fig. 3-1.

therefore determines the $20 \mu\text{s}$ interval between gating pulses. The CRT is blanked during the $3 \mu\text{s}$ gating pulse.

Lead Time During Real Time Sampling

The Real Time Oscillator, located in the vertical plug-in unit, and the Real Time Multivibrator operate only on the three Real Time sweep ranges. The Real Time Oscillator furnishes a strobe pulse to the sampling heads in the vertical plug-ins. The strobe pulse causes the sampling heads to sample the vertical input signal. The amplitude of the input signal is measured at this instant (when the sampling head is strobed) and the signal value is stored in the vertical memory until the next sample is taken $20 \mu\text{s}$ later. Samples are not displayed until $3 \mu\text{s}$ after they are taken because the CRT is blanked during the $3 \mu\text{s}$ memory gating pulse. Since the voltage applied to the horizontal deflection plates is changing during this $3 \mu\text{s}$ blanking interval, all samples are displayed approximately $3 \mu\text{s}$ to the right of where they might be expected to occur. This effectively gives the 7T11 lead time during real-time sampling and results in the triggering point being displayed approximately $3 \mu\text{s}$ after sweep start.

During the sweep illustrated in Fig. 3-3, strobe pulses are shown occurring $10, 30, 50, 70$ and $90 \mu\text{s}$ after sweep triggering. Vertical samples taken at these times would be displayed $13, 33, 53, 73$ and $93 \mu\text{s}$ after sweep start. No fixed time relationship exists between the triggering point on the signal and the occurrence of the first strobe. This is ensured by frequency modulating the 50 kHz Real Time Oscillator, which determines strobe timing, at an approximate 200 Hz rate. Frequency specifications for the Real Time Oscillator are given in Section 1 of the 7S11 Instruction Manual.

The time interval, between trigger recognition (T_0) and the first strobe, varies in value from $0 \mu\text{s}$ to $20 \mu\text{s}$, so all parts of a repetitive signal will be sampled after a number of sweeps have occurred. When a sweep occurs in which the first strobe is at trigger recognition (T_0), the triggering point of the signal will be displayed approximately $3 \mu\text{s}$ after sweep start. Unless the sweep repetition rate is very slow, the persistences of the CRT phosphor and the viewers eye result in a display of samples taken during more than one sweep. This gives the sweep a more continuous appearance.

Samples/Division Using Real Time Sampling

In Fig. 3-3, samples are being taken at $20 \mu\text{s}$ intervals and the ramp voltage is changing at an average rate of $2 \text{ mV}/\mu\text{s}$. The displayed output of the Horizontal Memory therefore changes in 40 mV steps. The CRT is blanked during the shaded $3 \mu\text{s}$ intervals. Each time the CRT is unblanked, a spot appears $1/25$ th of a division to the right of its previous position. One sweep consists of 250 dots or samples. The amplitude of the first step in the Horizontal Memory output, as well as its distance from sweep start, depends upon the time between sweep trigger and the first strobe.

Since the dots on the CRT, representing samples taken, occur at $20 \mu\text{s}$ intervals, increasing the sweep rate by positioning the TIME/DIV control to a more clockwise setting increases the horizontal distance between samples. Fewer samples per sweep will therefore be displayed. Counterclockwise rotation of the SWEEP RANGE control selects faster ranges. Rotating the SWEEP RANGE control counterclockwise steepens the TTH ramp, increasing the amplitude of the Horizontal Memory Output voltage steps and reducing the number of steps required to move the sweep ten horizontal divisions.

Summary of Real Time Basic Block Diagram

The basic block diagram for Real Time (Fig. 3-1) shows a system very similar to a standard real-time oscilloscope. The arrival of a trigger starts the timing ramp, or Time to Height Converter (TTH). The 50 kHz Real Time Oscillator supplies strobe pulse to the Real Time Multivibrator every $20 \mu\text{s}$. When a strobe occurs, the Real Time Multivibrator

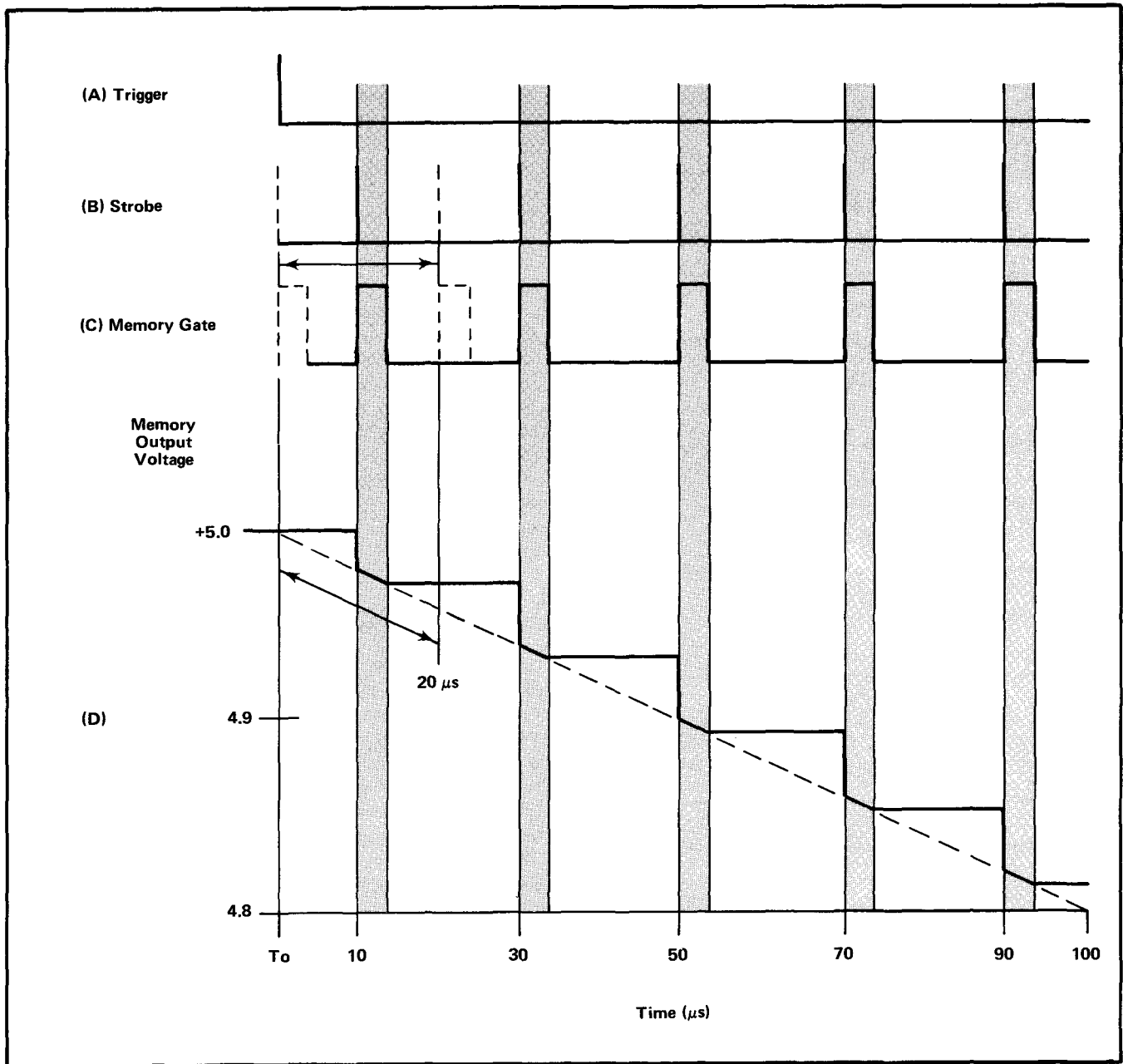

Fig. 3-3. Timing relationships during the first 1/50th of one typical Real-time sweep. 7T11 control settings as given in Fig. 3-1.

fires, causing the Memory Gate to conduct for about 3 μ s. The CRT is blanked by the interdot blanking circuit during this 3 μ s period. The memory tracks along with the amplified TTH ramp until the gate quits conducting. The CRT is then unblanked and the memory voltage remains constant until the next memory gating pulse arrives approximately 17 μ s later. The width of the memory gating pulse sets the lead time of the instrument. During Real Time sampling this lead time is about 3 μ s. For each triggering event, one sweep across the screen is produced. The display created during each sweep consists of a series of dots spaced at 20 μ s intervals. At the faster real-time sweep rates the number of dots displayed per sweep decreases.

Additional Real-Time Circuits

Fig. 3-4 shows a number of circuits and controls that did not appear in the basic block diagram of Fig. 3-1. The additional circuit blocks are: Start Multivibrator, Reset Comparator, and HOMV (hold-off multivibrator). Operating controls shown on this block diagram are: SWEEP RANGE, TIME/DIV, and TIME POSITION.

The block labeled Trigger in Fig. 3-1 is labeled Trigger and Output TD in Fig. 3-4. This block represents all circuits through which the triggering signal passes before arriving at

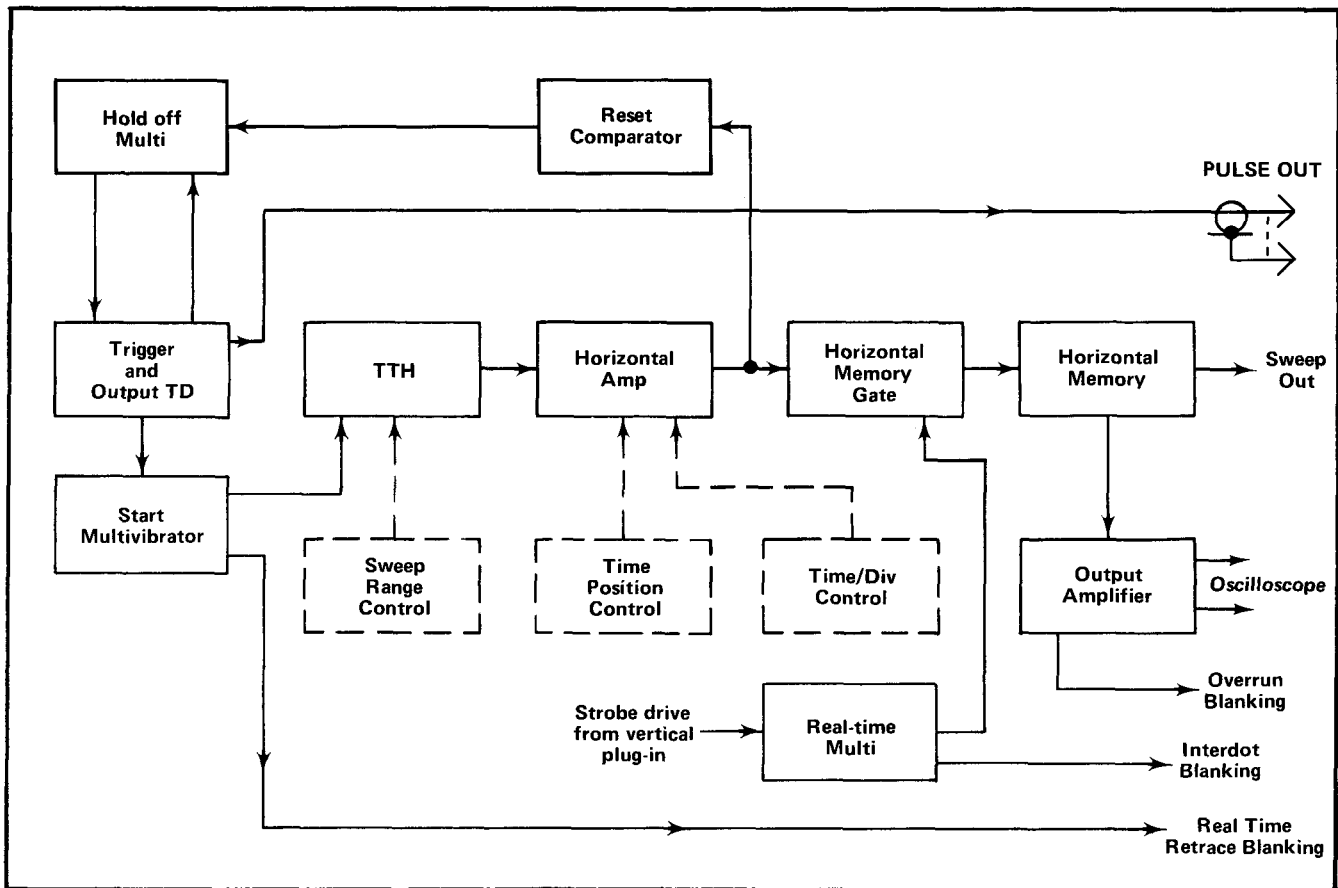

Fig. 3-4. 7T11 complete block diagram for Real-time sampling.

the Trigger Output tunnel diode. The time at which the trigger signal causes the Trigger Output TD to fire is referred to as trigger recognition or time t_0 . The Trigger circuit switches the Start Multivibrator circuit, which in turn sends a start pulse to the TTH. The Start Multivibrator also determines when Real-Time retrace blanking operates. The Reset Comparator is provided to stop the rise in the Horizontal Amplifier output voltage when the voltage reaches a value of about +5.2 volts. When the output voltage of the Horizontal Amplifier reaches the reset value, the Reset Comparator produces an output that causes the HOMV to reset the Trigger and TTH circuits. This ends the sweep and provides real time retrace blanking.

The HOMV prevents triggering until the sweep has ended and adequate holdoff time has been provided for the TTH to recover. The HOMV then resets, permitting trigger recognition.

Controls Affecting Timing and Delay

SWEEP RANGE Control. The Sweep Range control determines the basic timing of the 7T11 and the available amount of Time Positioning Range. The rate of change, or slope, of the TTH ramp changes by a factor of ten as the SWEEP RANGE control is rotated between positions.

Fig. 3-5 shows the rate of change of the TTH output voltage for the three Real-time Sweep Ranges. It should be noted that a different time scale is used in Fig. 3-5 for each of the ranges. The second ramp is ten times as fast as the first, and the third range provides a ramp that is ten times as fast as the second. The TTH ramp voltage runs from 0 volts to -5 volts in a time interval equal to ten times the slowest available TIME/DIV setting.

TIME/DIV Control. Figure 3-4 shows that the TIME/DIV control operates on the Horizontal Amplifier block. Changing the setting of the TIME/DIV control changes the gain of the Horizontal Amplifier and thereby changes display magnification. Display magnification varies from X1 to X500 depending upon the location of the TIME/DIV setting within the window provided on the front panel control. Refer to Fig. 2-6 in the Operating Instructions section of this manual.

Display magnification is X1 at the slowest TIME/DIV setting available on each of the seven positions of the SWEEP RANGE control. At TIME/DIV settings providing X1 magnification, a 5 volt change in the TTH output will cause the output of the Horizontal Amplifier to change 5 volts. At TIME/DIV settings providing greater than X1 magnification, less than 5 volts is required at the Horizontal Amplifier input to obtain a 5 volt output.

Circuit Description—7T11

With the SWEEP RANGE control in the 5 ms/div to 10 μ s/div position and the TIME POSITION control fully CW, switching the TIME/DIV control from 5 ms/div (as shown in Fig. 3-5) to 1 ms/div results in only the first 10 ms of the TTH ramp being used. During this time interval the TTH ramp will run from 0 volts down to -1 volt. This change in TIME/DIV setting changes the Horizontal Amplifier gain from 1 to 5. The 1 volt change at the TTH output will end up as a 10 volt change at the memory output and therefore 10 divisions of horizontal deflection on the CRT. Magnification is X5.

TIME POSITION Control. Fig. 3-4 shows that the TIME POSITION control also operates on the Horizontal Amplifier block. Essentially the TIME POSITION control delays the start of the magnified linear sweep delivered to the Horizontal Memory Gate. See Fig. 3-6.

The TIME POSITION control determines the time separation between the start of the TTH ramp and the start of the ramp from the Horizontal Amplifier. With the control settings given in Fig. 3-6, TIME POS RNG is 50 ms. Fig. 3-6A shows the time relationship of the TTH and Horizontal Amplifier outputs with the TIME POSITION control fully clockwise, while Fig. 3-6B shows the time relationship with TIME POSITION fully counterclockwise. Any value of delay between that shown in Fig. 3-6A and 3-6B is available at intermediate positions of the TIME POSITION control.

In Fig. 3-6C the TIME POSITION control is set to mid-position and the TIME/DIV control has been switched from 5 ms/div to 1 ms/div (X5 Mag). Before the arrival of the Trigger, the output of the TTH and the Horizontal Amplifier is at zero, and the Horizontal Memory output is at +5 volts. The dot is blanked. The arrival of a trigger pulse starts the TTH running negative. The Horizontal Amplifier still remains at zero until the TTH output voltage passes -2.5 volts; its output then rises positive 1 volt per 2 ms. The Horizontal Memory follows this amplified and delayed ramp in the form of a staircase, stepping negative as the strobos arrive. The sweep continues until the output of the Horizontal Amplifier reaches a voltage of approximately +5.2 volts. Then the Reset Comparator operates, resetting the HOMV, Trigger, and TTH circuits.

Important Waveform Relationships

Assume that the TTH has recovered from the previous sweep and that Trigger Output TD is armed and ready to be triggered. The arrival of a suitable triggering signal causes the output TD to switch to its high state at a time designated as T_0 on Fig. 3-7. When the Output TD switches, it causes a positive pulse to appear at the front panel PULSE OUT connector. This positive pulse ends when the output TD returns to its low state. Switching of the Output TD also causes a signal to be sent through trigger output and coupling circuits to the Start Multivibrator, which starts the negative-going TTH ramp.

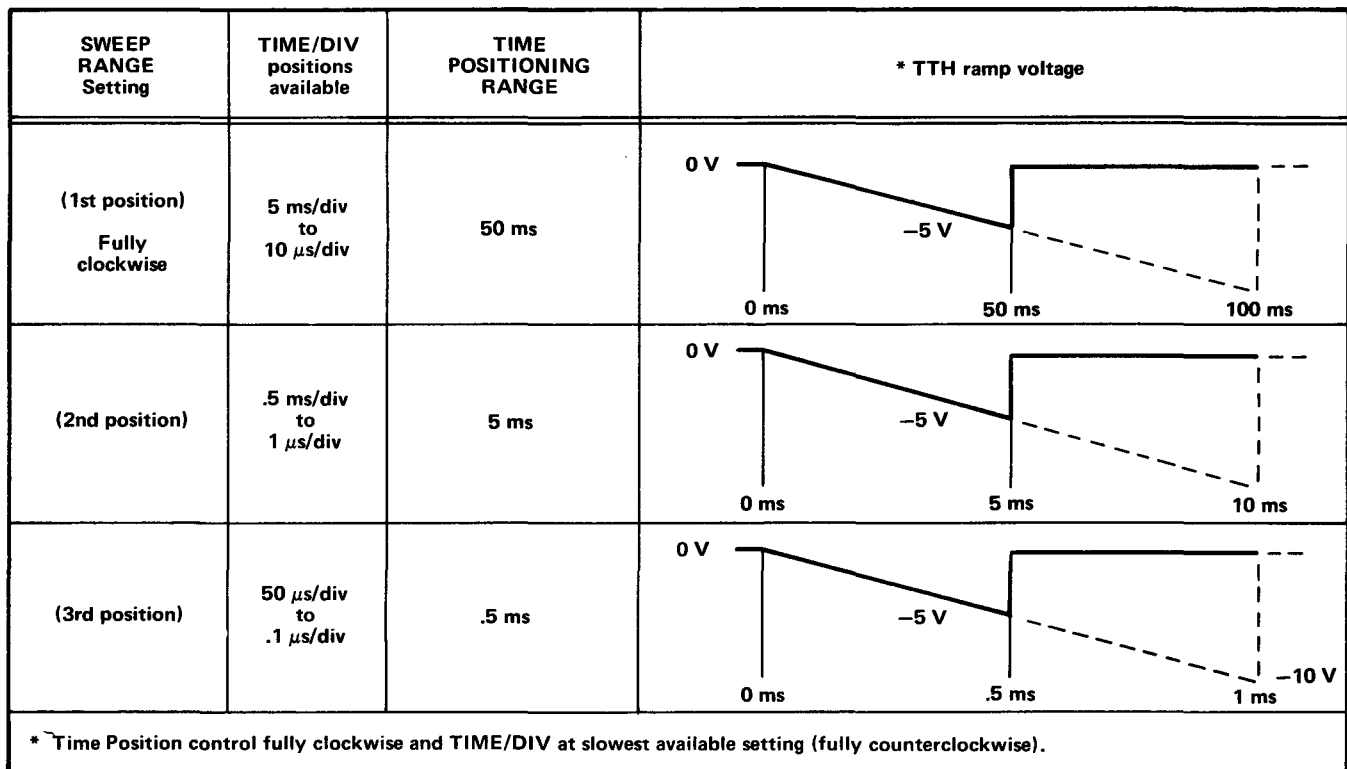

Fig. 3-5. TTH ramp voltage versus time at the three Real-time positions of the SWEEP RANGE control.

Strobe pulses are occurring at intervals of approximately 20 μ s; causing sampling of the vertical signal, gating of the Horizontal Memory, and interdot blanking for a period of about 3 μ s out of each 20 microseconds (see Fig. 3-3). While the Output TD is at its high level, the Start Multivibrator is held ON. With the Start Multivibrator ON, retrace blanking is disabled and blanking is controlled by the interdot and overrun blanking circuits.

After an interval of time determined by an RC circuit in an input to the A section of the HOMV, outputs of HOMV sections A and B switch (see Fig. 3-7). This switching occurs at a time referred to as 1/2 hold-off interval and occurs approximately 1 ms after T_O on the three Real-time Sweep Ranges. The switching of HOMV sections A and B result in one of the C inputs rapidly rising to the level required to switch the outputs of HOMV sections C and D. Sections C and D will not switch, however, until both C inputs are at the required positive level.

The output of the Horizontal Amplifier does not start rising until 2.5 ms after T_O since the conditions stated on Fig. 3-7 specify that 2.5 ms of time positioning is in use. During the time interval from 2.5 ms to 7.7 ms after T_O , the Horizontal Amplifier output changes from 0 volts to approximately +5.2 volts. When the output of the Horizontal Amplifier reaches about +5.2 volts the Reset Comparator drives the other section C input (pin 9) positive. The C section output of the HOMV switches, causing the D section to switch.

When the D output of the HOMV switches (shown at 7.7 ms on Fig. 3-7) it causes switching of the Trigger Output TD to its low level. This causes the Start Multivibrator to shut off; this ends the TTH ramp, permits retrace blanking to operate, and ends the output from the PULSE OUT connector.

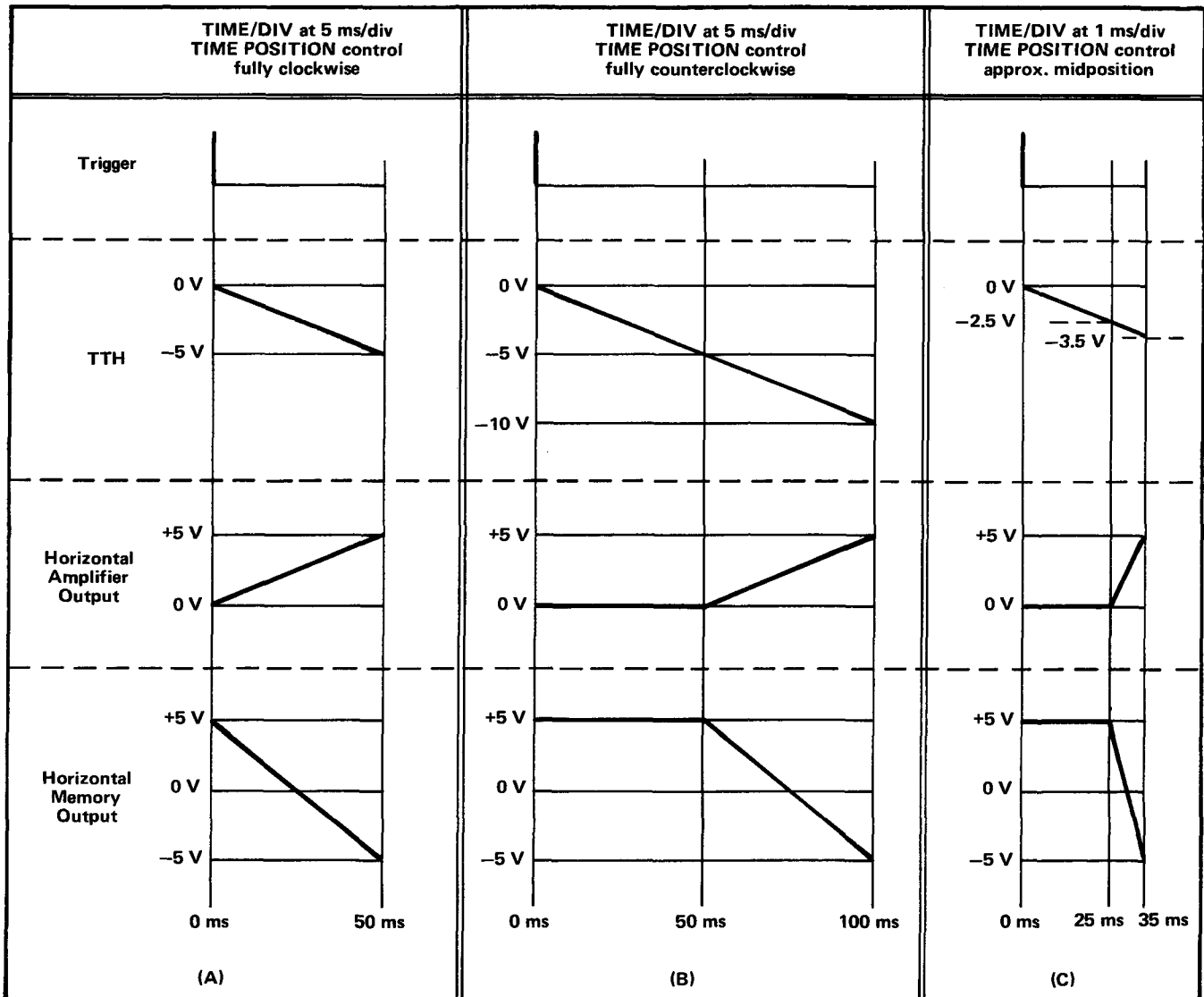
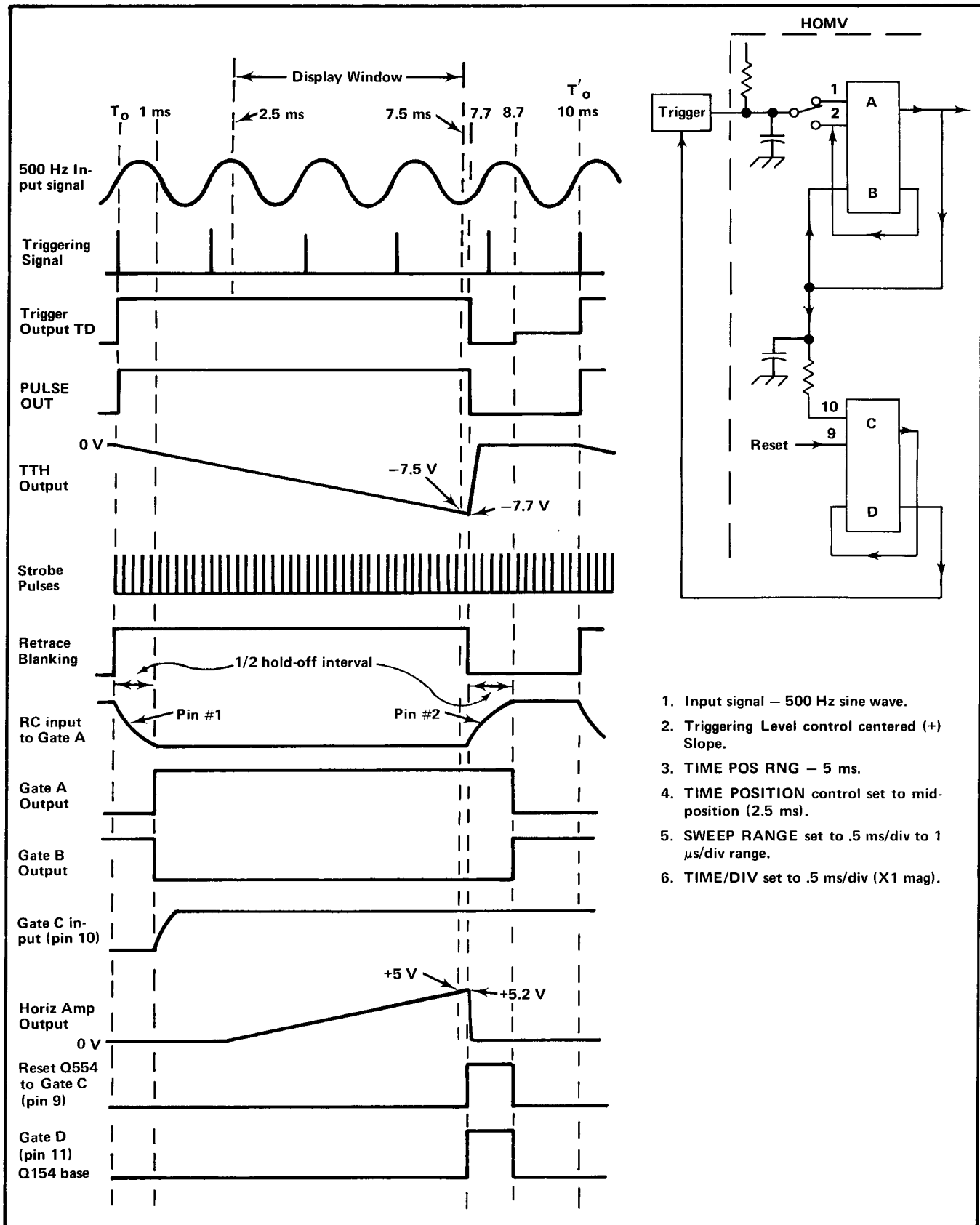

Fig. 3-6. Effect of TIME POSITION and TIME/DIV controls. SWEEP RANGE set at 5 ms/div to 10 μ s/div position.



1. Input signal - 500 Hz sine wave.
2. Triggering Level control centered (+) Slope.
3. TIME POS RNG - 5 ms.
4. TIME POSITION control set to mid-position (2.5 ms).
5. SWEEP RANGE set to .5 ms/div to 1 μ s/div range.
6. TIME/DIV set to .5 ms/div (X1 mag).

Fig. 3-7. Ideal Trigger, Sweep, and HOMV waveform relationships during real-time sampling.

After an interval of time (1/2 hold-off interval) determined by the RC previously mentioned, HOMV Sections A, B, C and D return to their quiescent state (8.7 ms after T_0 on Fig. 3-7). The Arming and Output TD's are now returned to a ready-to-fire condition. The next incoming trigger (10 ms in Fig. 3-7) will be recognized and the cycle repeats.

The minimum hold-off time on the three real-time ranges is approximately equal to the sum of the two 1/2 hold-off intervals (a total of about 2 ms). At the slower real-time sweep rates or when time positioning is used, hold-off time increases and the maximum triggering rate therefore decreases.

THEORY OF OPERATION SEQUENTIAL EQUIVALENT-TIME SAMPLING

Additional Circuits Required

Fig. 3-8 shows a simplified block diagram of circuits required for sequential equivalent-time operation of the 7T11. Comparison of Fig. 3-8 with the real-time block diagram shown in Fig. 3-4 shows that the Reset Comparator and Real Time Multivibrator are not used during equivalent-time operation.

Additional circuits (shown in Fig. 3-8), required during sequential operation are: Slewing Ramp, Slewing Comparator, Slow Ramp Generator, Slow Ramp Inverter, Dot Position Comparator, and Dot Position Memory.

Slewing Ramp. The Slewing Ramp is a fast ramp that is started at the same time as the TTH ramp and runs negative at the same rate. Its slope is determined by which of the four equivalent-time Sweep Ranges is selected. The output of the Slewing Ramp is fed to one input of the Slewing Comparator, where its voltage is compared to the inverted output of the Slow Ramp Generator.

Slow Ramp. The Slow Ramp Generator output, after passing through the Slow Ramp Inverter, provides an input reference voltage to the Slewing Comparator against which the output of the Slewing Ramp is compared.

The output of the Slow Ramp Generator rises from 0 volts to slightly more than +10 volts and is then reset by a reset multivibrator. After a short hold-off interval, a negative-going output of the HOMV is able to again shut off the reset multivibrator, permitting generation of another slow ramp.

The rate of rise and therefore the time required to generate the Slow Ramp is controlled by the SCAN control. On equivalent-time ranges and with REP SCAN selected, the SCAN control permits controlling the dot density of the display.

Slow Ramp Inverter. The Slow Ramp Inverter inverts the Slow Ramp output. The negative-going output of the Inverter is applied to the Slewing Comparator.

The TIME POSITION control introduces offset to the Slow Ramp Inverter input to compensate for the offset introduced into the Horizontal Amplifier by the Time POSITION control. Unless this is done the TTH ramp could be stopped by the comparator before any change in voltage appeared at the output of the Horizontal Amplifier.

Slewing Comparator. The purpose of the Slewing Comparator is to compare the output of the Slewing Ramp with the output of the Slow Ramp Inverter. When these two inputs to the comparator are equal, the comparator delivers an output. The Slewing Comparator output initiates the strobe pulses that are delivered to the vertical unit sampling heads and cause them to sample the input signals. The Slewing Comparator output also stops the negative-going TTH ramp. This stopped level is then amplified and read into the Horizontal Memory at 1/2 hold-off time.

Dot Position Comparator and Memory. Factors determining the timing and linearity of the CRT display are the cleanliness of the TTH, Horizontal Amplifier, Horizontal Memory, and output circuits. The nonlinearities and distortions present in the Slewing Ramp, Slewing Comparator, and Slow Ramp circuits do not affect display timing and linearity. The independence of these two groups of circuits cause the timing of the output from the Slewing Comparator to be critical.

If the Horizontal Amplifier is set to a magnification ratio of 50, a 0.1 volt excursion of the TTH shows up as a 10 volt excursion at the output of the Horizontal Memory. Also, the Time Position control can be set so that the TTH must go through an excursion of 5 volts before the Horizontal Amplifier becomes operative. It is this situation that makes the timing of the Slewing Comparator output very critical.

Since the timing of the Slewing Comparator output sets the output level of the TTH, and since this firing is dependent upon the programmed level set by the Slewing Ramp, Slewing Comparator, Slow Ramp, and Slow Ramp Inverter, it is easy to see that a few millivolts of programming error can cause the TTH to be stopped at a level corresponding to an off screen dot position. The Dot Position Comparator and Dot Position Memory are provided to prevent this programming error.

The Dot Position Comparator compares the voltage from the Horizontal Memory (via the Output Amplifier) with the Slow Ramp voltage. If the Memory voltage is not at the correct level, an error signal causes the Dot Position Memory to shift level. This new DC level is fed back to the Slow Ramp Inverter to slide the next sample closer to the correct

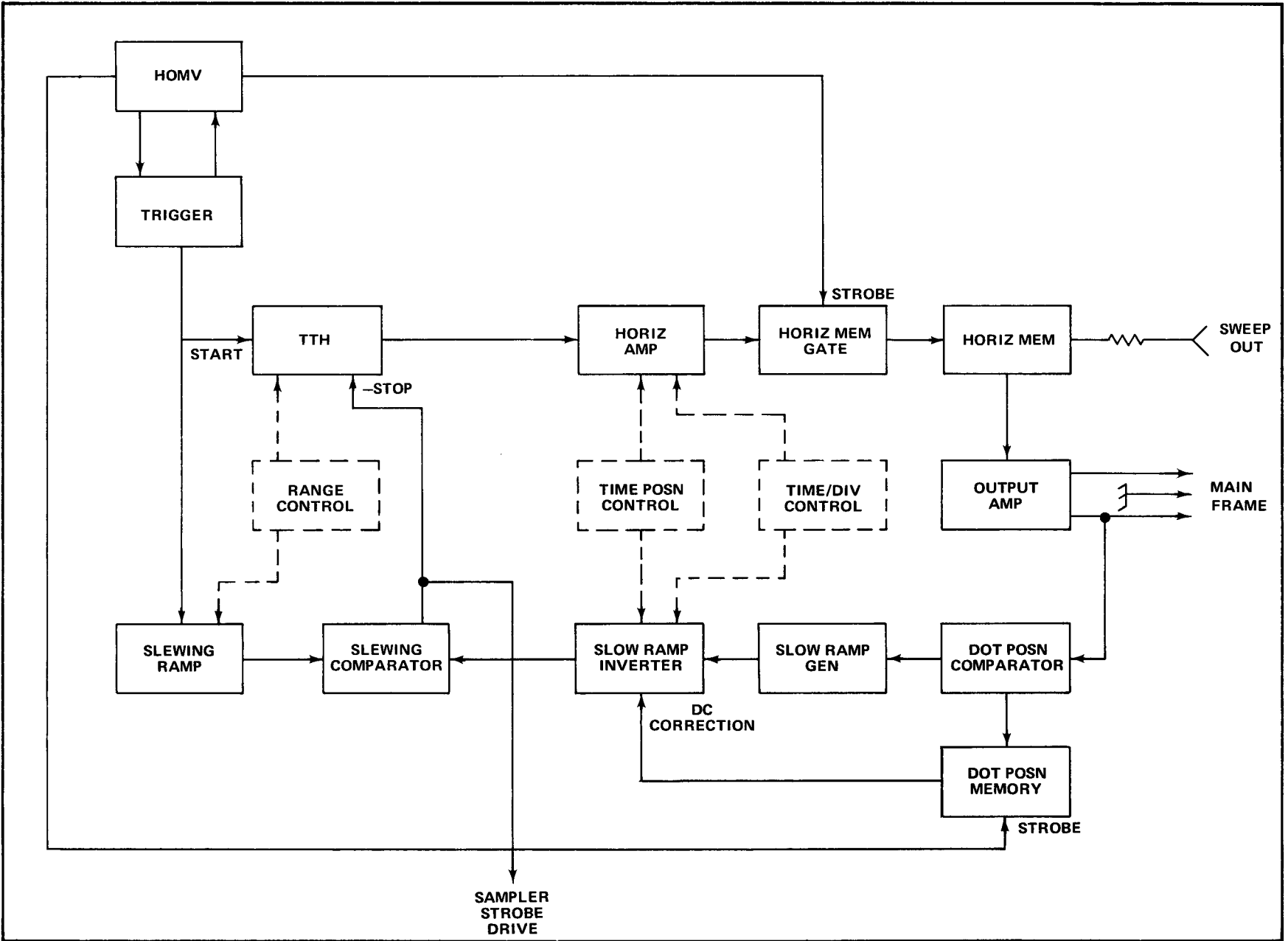

Fig. 3-8. Simplified sequential equivalent-time block diagram.

position. Care is taken to make the strobe slewing and the TTH system track each other, so only a small position error remains to be corrected by the Dot Positioning circuits.

Constructing the Display

One major difference between real-time and equivalent-time sampling in the 7T11 is the manner in which the display is constructed on the CRT. During real-time operation many samples of the vertical input signal are normally taken during one horizontal sweep. During equivalent-time operation only one sample of the vertical input signal is taken and one dot is displayed for each input trigger. In Fig. 3-9, ideal waveforms are shown for the 7T11 sequential equivalent-time sampling.

Each time a trigger is recognized (time T_0) a new TTH sweep is generated. When the output level of the fast ramp generator (the Slewing Ramp) equals that of the Slow Ramp Inverter, a sampling head strobe pulse is generated and the vertical input signal is sampled. The signal amplitude is stored in the vertical memory. The CRT is blanked when the strobe occurs and the change in TTH output voltage is stopped.

The TTH voltage, after passing through the Horizontal Amplifier and the X2 gain of the Horizontal Memory, is stored in the Horizontal Memory by turning on the Memory Gate for approximately $2 \mu\text{s}$ at the $1/2$ hold-off time. The CRT is then unblanked, permitting display of a dot at a position determined by the voltages stored in the vertical and horizontal memories. After a suitable hold-off interval, determined by the HOMV, the circuits are returned to normal and another triggering signal can be recognized.

When the next trigger signal is recognized (shown at $25 \mu\text{s}$ in Fig. 3-9) the TTH and Slewing Ramp again start running negative at the same rate. Since the output voltage of the Slow Ramp is continuously changing at a slow rate the Slewing Ramp must run slightly more negative this time. The strobe pulse therefore occurs at a slightly later time with respect to trigger recognition (T_0).

Each sample results in the display of a dot slightly to the right of the dot representing the preceding sample. This increase in delay between T_0 and the strobe pulse continues until dots have been placed horizontally completely across the CRT. The Slow Ramp resets and another equivalent time display is then started at the left of the CRT and progresses slightly to the right at each sample as the process repeats.

The number of recognized triggers required to construct one equivalent time sweep is dependent upon how close together horizontally the samples are spaced. This is dependent upon dot density or samples per sweep. The SCAN control permits changing the Slow Ramp slope and thereby changing dot density.

Waveform Relationships

Fig. 3-9 shows ideal waveform relationships for sequential equivalent time sampling. Minimum trigger hold-off time for the three fastest equivalent time ranges is at least $25 \mu\text{s}$. The HOMV will not permit triggering at intervals of time closer than $25 \mu\text{s}$ regardless of the input trigger repetition rate. For purposes of explanation, triggering is at $25 \mu\text{s}$ intervals, and the following control settings are assumed:

TIME POSITION	fully clockwise
SWEEP RANGE	$.5 \mu\text{s}/\text{div}$ to $1 \text{ ns}/\text{div}$
TIME/DIV	$.5 \mu\text{s}/\text{div}$
SCAN	adjusted to $50,000 \mu\text{s}$ per sweep (about a 20 Hz rate)

When the Output TD switches to its high state at time (T_0), the TTH and Slewing Ramps start running negative at the same rate. The Slow Ramp is assumed to have started its run from 0 volts to +10 volts $25,000 \mu\text{s}$ previously and has completed $1/2$ of its positive run. The Slow Ramp output is therefore +5.0 volts. At the control settings given above, the horizontal amplifier gain is X1 and therefore no attenuation is introduced at the Slow Ramp Inverter input. The Slow Ramp Inverter gain is set at 0.5 so the +5 volt input signal will appear as a -2.5 volt signal at the output. The -2.5 volt output of the inverter is fed to one input of the comparator. When the Slewing Ramp output voltage applied to the comparator reaches a value equal to that applied by the Slow Ramp Inverter, the comparator output goes positive.

The comparator output stops the negative-going TTH ramp and prevents the Slewing Ramp from going below the level of the Slow Ramp. At the same time the comparator enables the 7T11 interdot blanking and causes a strobe pulse to be sent to the sampling heads in both Sampling Unit plug-ins. This is shown occurring at $2.5 \mu\text{s}$ after T_0 on Fig. 3-9. The sampling heads sample the input signals and the signal amplitudes are stored in the vertical memories. No spot will appear on the CRT at this time since the interdot blanking is operative.

After an interval of time determined by an RC circuit in the HOMV, the A output of the HOMV switches to a more positive level. This switching occurs at a time referred to as $1/2$ hold-off interval and is shown occurring at $10 \mu\text{s}$ in Fig. 3-9. This $10 \mu\text{s}$ is the absolute minimum time duration that will permit a full 10 division sweep at a TIME/DIV setting of $.5 \mu\text{s}/\text{div}$ and with the full $5 \mu\text{s}$ of available time positioning range in use. The actual value of $1/2$ hold-off interval must therefore be somewhat longer than the $10 \mu\text{s}$ shown.

Switching of the HOMV section A causes the Horizontal Memory Gate to be turned on. The -2.5 volt level of the TTH appears at the Horizontal Amplifier output as a +2.5 volt level, and at the Horizontal Memory output as a 0 volt

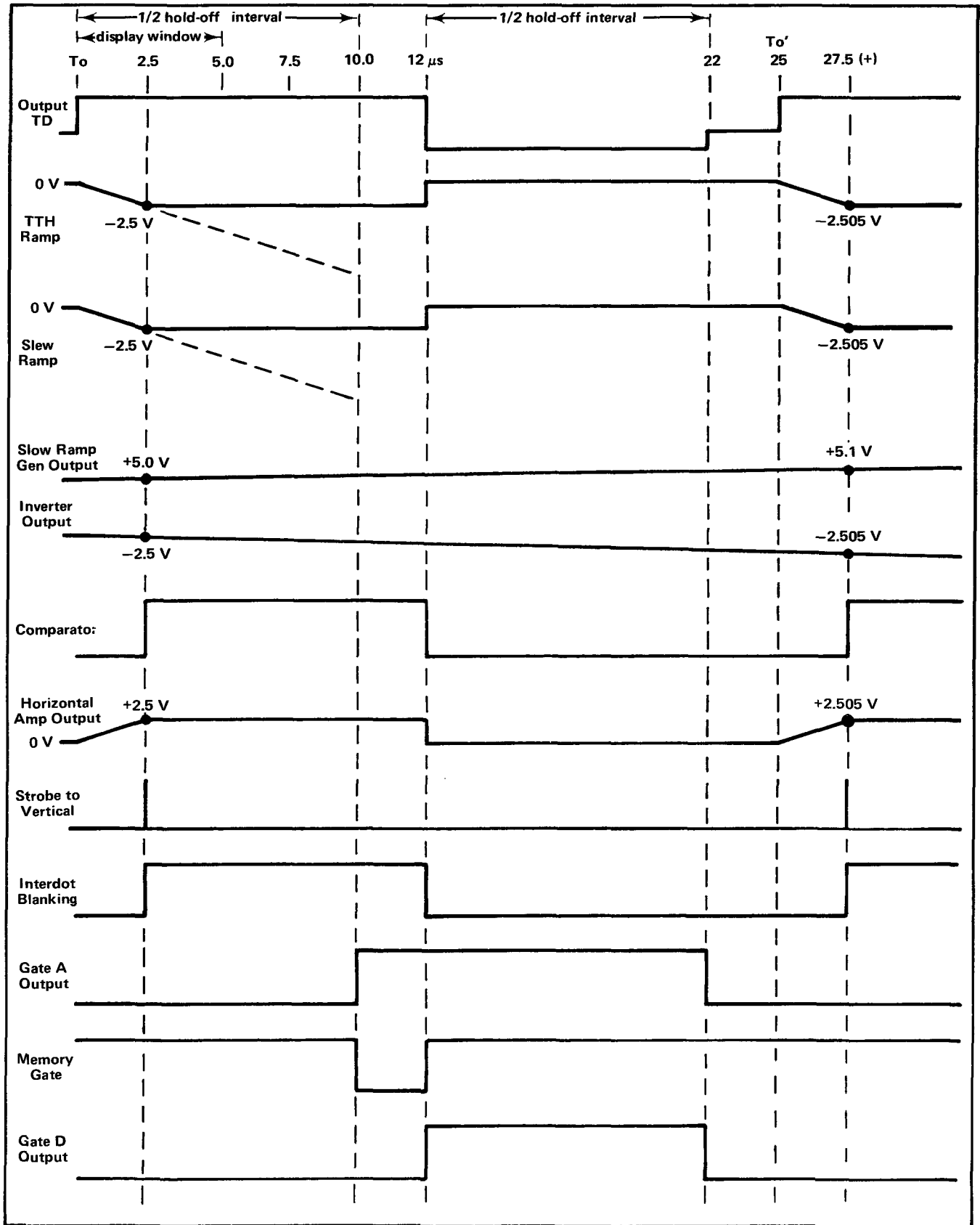

Fig. 3-9. Ideal waveform relationships during sequential equivalent time sampling.

output level. These voltage relationships are illustrated in Fig. 3-2.

After an interval of about $2 \mu\text{s}$, as determined by a second RC circuit in the HOMV, the D output of the HOMV switches to its high level. See Fig. 3-9. Gate D, shown as switching at $12 \mu\text{s}$ after T_0 , ends the Horizontal Memory gating pulse. Interdot blanking is disabled and a dot appears on the CRT at a position determined by the voltage level stored in the vertical and horizontal memories. Since the Horizontal Memory output voltage is now 0 volts, the dot is positioned at the horizontal midposition (at the $2.5 \mu\text{s}$ position on the display).

The switching of HOMV section D ($12 \mu\text{s}$ after T_0) also causes the Output TD to return to its low state and the TTH, Slewing Ramp, and Horizontal Amplifier outputs to return to their 0 volt level. After another interval of at least $10 \mu\text{s}$ ($1/2$ hold-off interval) the HOMV permits rearming of the Output TD to a "ready-for-trigger" condition.

In Fig. 3-9 triggering is shown to occur again at $25 \mu\text{s}$ and the cycle repeats. Since the Slow Ramp voltage is steadily rising toward its 10 volt limit, the Slow Ramp voltage is slightly more positive than at the previous T_0 and the Slewing Ramp must run more negative before the comparator output again occurs. The output of the Horizontal Memory is now -10 mV when unblanking occurs, instead of the 0 volts present following the previous T_0 . A dot appears on the CRT positioned $1/100$ th of a division to the right of the previous dot.

Ideally, if triggering continues to occur at $25 \mu\text{s}$ intervals, dots will continue to be placed $1/100$ th of a division to the right of the previous dot at intervals of $25 \mu\text{s}$ until the Slow Ramp reaches its approximate +10 volt limit. When the Slow Ramp reaches +10 volts, the Reset Multivibrator provides retrace blanking and resets the Slow Ramp to zero. After a hold-off interval, the Slow Ramp can again be started.

Turning the TIME POSITION control fully CCW affects the waveforms (of Fig. 3-9) as shown in Fig. 3-10. With the full $5 \mu\text{s}$ of available time positioning in use, the time interval from $5 \mu\text{s}$ to $10 \mu\text{s}$ after T_0 is displayed.

The Time Position control provides an offset current to the Slow Ramp Inverter input that causes the Inverter output to be shifted negative by 5 volts. If at the time indicated as $7.5 \mu\text{s}$ on Fig. 3-10, the Slow Ramp Generator is delivering +5 volts to the Inverter input, this signal will appear as an additional -2.5 volt signal at the output. Adding this -2.5 volt signal to the -5 volts produced by the Time Position control results in a -7.5 volts at the Inverter output.

Factors Affecting Dot Density. On the three fastest equivalent-time sweep ranges, the triggering interval can be no less than about $25 \mu\text{s}$. As the trigger repetition rate is reduced so that the interval between triggers is more than $25 \mu\text{s}$, a reduction in dot density becomes apparent. This is because the dot density is dependent on the amount of change in the Slow Ramp voltage. An interval longer than the $25 \mu\text{s}$ minimum triggering interval permits a greater change in the slow ramp voltage and therefore increased dot spacing.

Switching the Sweep Range control between the three fastest equivalent-time ranges has no noticeable affect on samples taken per sweep, but when the slowest equivalent-time Sweep Range ($5 \mu\text{s}/\text{div}$ to $10 \text{ ns}/\text{div}$) is selected, the HOMV range capacitor is changed. The HOMV now permits

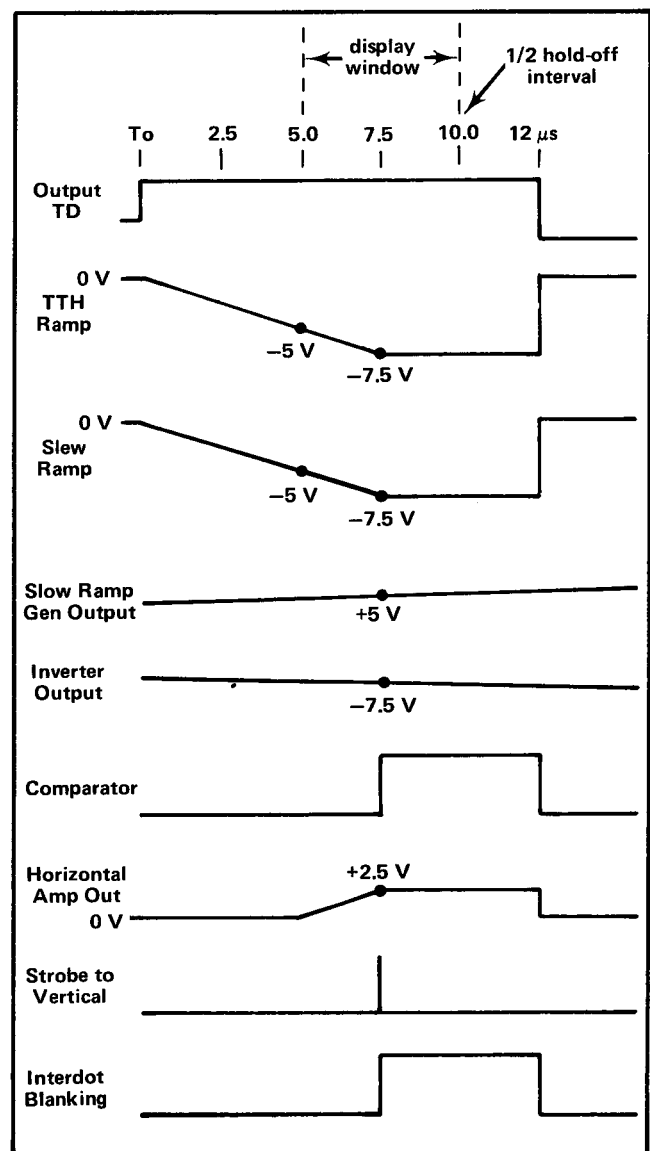

Fig. 3-10. Effect of turning TIME POSITION control fully CCW on waveforms of Fig. 3-9.

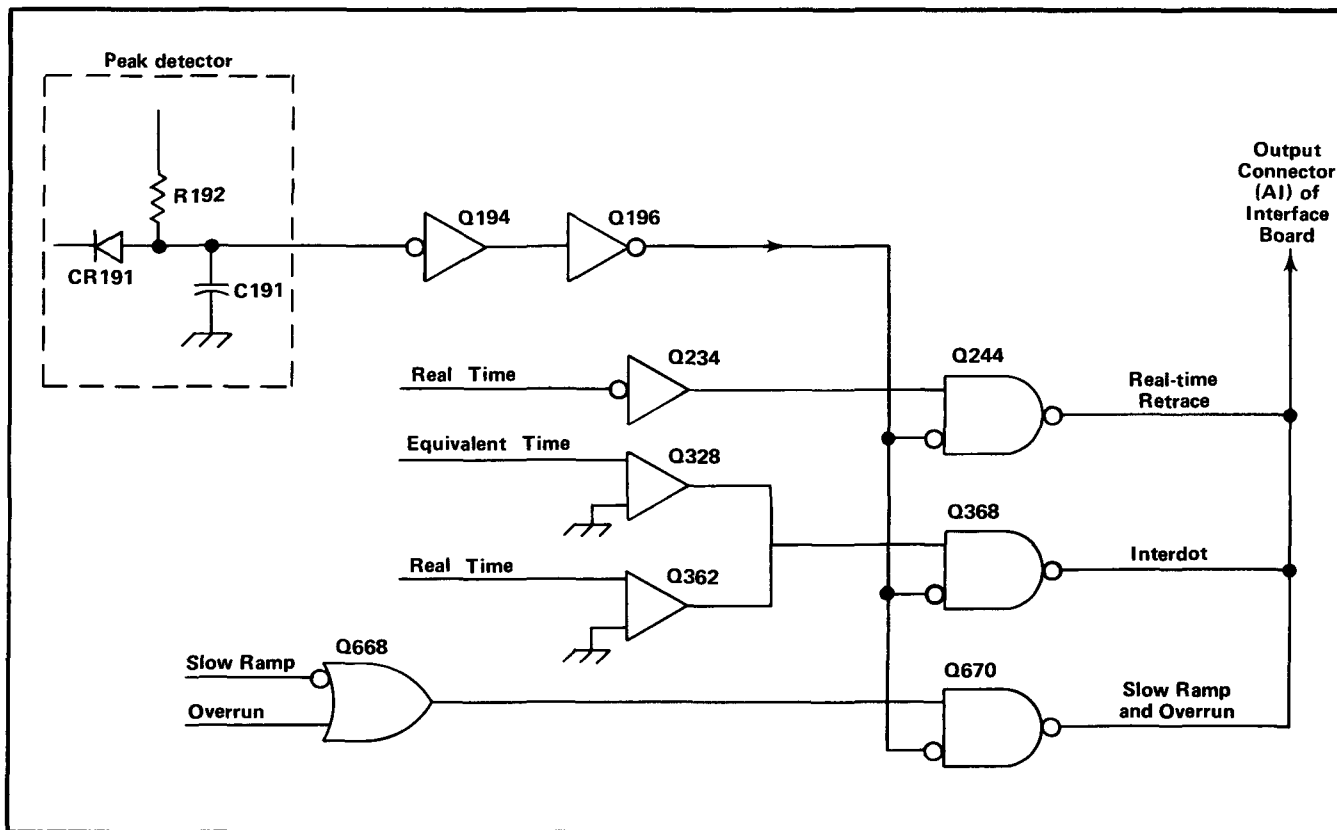

Fig. 3-11. 7T11 Blanking logic.

triggering at intervals no closer than 200 μ s. Since the slow ramp voltage will change more in 200 μ s than in 25 μ s, if triggers are arriving at intervals closer than 200 μ s, switching from one of the three fastest equivalent-time ranges to the slowest equivalent-time sweep range reduces the dot density.

Changing the setting of the TIME/DIV control has no effect on dot density because an attenuator network, controlled by the TIME/DIV control, reduces the slope of the signal delivered to the Slow Ramp Inverter by the same factor as Horizontal Amplifier gain is increased. Also, dot density is not affected by rotation of the VARIABLE time per division control. Rotation of the VARIABLE control clockwise increases Horizontal Amplifier gain while reducing input to the Slow Ramp Inverter by the same factor.

Assume that the TIME/DIV control is at a position where Horizontal Amplifier gain is X1. The entire 5 volt output of the TTH will be used by the Horizontal Amplifier. Assuming 1000 samples per sweep, samples are taken at 5 mV intervals along the TTH ramp. With the TIME/DIV control at a setting providing X10 Horizontal Amplifier gain, only 0.5 volts of the TTH ramp is used to produce 10 divisions of horizontal deflection. In order to maintain the dot density (1000 samples/sweep was assumed) samples

must be taken at $0.5/1000 = 0.5$ mV intervals along the TTH ramp rundown. This is accomplished by reducing the rate of change of the slow ramp at the inverter input to one-tenth of its former value, using the attenuation network mentioned above.

In summary; the SCAN control affects dot density. Dot density may also be affected by the trigger repetition rate or by switching from one of the three fastest equivalent-time Sweep Ranges to the slowest equivalent-time Sweep Range. Dot density is not affected by switching from one TIME/DIV setting to another.

Blanking

Four types of blanking are provided in the 7T11: Interdot, Overrun, Real Time Retrace, and Slow Ramp Retrace (see Fig. 3-11). The first two types, Interdot and Overrun, are used during both real and equivalent time sampling. Real time retrace blanking is used during real-time operation while Slow Ramp retrace blanking is used during equivalent-time sampling.

The purpose of interdot blanking is to blank the CRT until the voltages representing the latest TTH and vertical

signal sample are stored in their respective memories. Fig. 3-3 shows that during real-time operation, interdot blanking occurs at the time a strobe pulse is delivered to the vertical unit and the horizontal memory is gated on. Fig. 3-9 shows that during equivalent-time operation, interdot blanking starts at the time of the vertical strobe pulse and ends when the horizontal memory gating pulse ends.

Overrun blanking prevents the display of a dot if either of the push-pull outputs of the Horizontal Amplifier exceeds +5 volts. This prevents display of undesirable parts of the sweep.

Both Real-Time retrace and Slow Ramp retrace blanking prevent the user from seeing the retrace portion of the sweep. Retrace blanking keeps the CRT blanked from the time the sweep ends until a new sweep starts.

The logic shown in Fig. 3-11 includes a peak detector. At normal trigger repetition rates the peak detector delivers a signal that permits normal operation of all four types of blanking. If a period of more than one or two seconds elapses between triggers, the output of the peak detector is lost and all blanking is disabled.

In the absence of triggers no sweep is present and if the CRT is blanked, the beam cannot be located using the oscilloscope beam finder. As explained above, blanking is disabled if more than a couple of seconds elapses between triggers and the beam finder will then function.

Unavoidable Delay Introduced by the 7T11

During sequential-equivalent-time sampling a fast rise, low repetition-rate pulse cannot be displayed using Internal triggering. The reason for this is illustrated in Fig. 3-12. With Triggering Level and Stability controls set to produce triggering as near as possible to the start of the pulse leading edge, some of the pulse leading edge occurs before the triggering level is reached and is therefore lost.

Another factor preventing display of the input signal leading edge is that triggering is not instantaneous. Time is required for the signal to travel to the trigger circuits and cause the Trigger Output TD to switch to its high state. By the time the Trigger Output TD switches (time T_0), the signal illustrated in Fig. 3-12 has reached its peak value. If a strobe pulse is delivered to the sampling bridge at this instant (time T_0) none of the leading edge of the input pulse is displayed. The display window has been shifted to the right since its start is delayed by the same amount as T_0 lags the triggering level.

If the Slow Ramp is at zero, the Comparator should produce a strobe pulse at time T_0 for delivery to the sam-

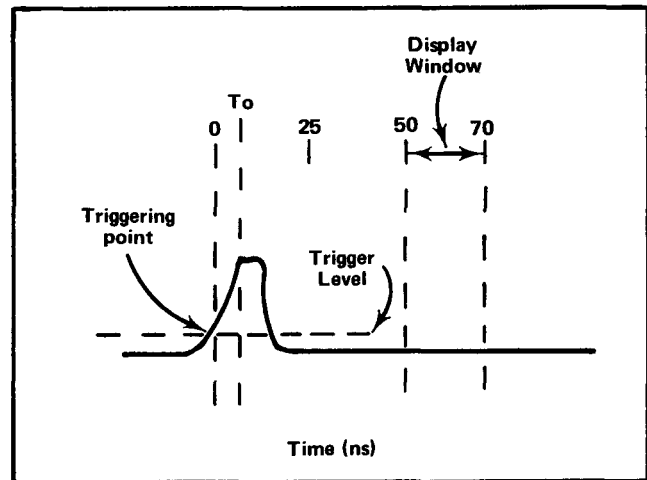

Fig. 3-12. Unavoidable delay between trigger point on input signal and start of display window.

pling heads. Some lag exists between T_0 and production of the strobe pulse and additional time is required for the strobe to travel from the 7T11 to the Vertical Unit and thence to the sampling bridge. If the sampling head is operating on an extender cable, or a probe type sampling head such as the Tektronix Type S-3 is used, the travel time is further increased. The display window is shifted due to this travel time. In Fig. 3-12 the display window is shown extending from 50 ns to 70 ns after the triggering level is reached. With the input signal shown, delivering strobe pulses to the sampling bridge during the interval from 50 ns to 70 ns will result in sampling the vertical input signal after it has returned to zero. A straight line will therefore be displayed horizontally across the CRT.

The display window can be moved further to the right on Fig. 3-12 by further delaying the start of the sweep. Turning the Time Position control CCW increases the amount of delay between T_0 and the start of the display window. If the time between input pulses is not too long and repetition rate is constant, a display can be created by triggering on one input pulse and delaying the display window so that the strobe pulses arrive at the sampling head coincident with the next input pulse. Setting the triggering level and slope controls for triggering on the trailing edge of the input pulse shown in Fig. 3-12 reduces the delay (time positioning) required.

Two methods of starting the sweep and strobing the sampling heads before the input signal reaches the sampling bridges are discussed in Section 2 of this manual. The first method is to introduce delay in the vertical signal path between the signal source and the input to the sampling head. A Tektronix 7M11 Delay Line can be used for this purpose. The second method requires use of a signal source providing a Pretrigger. In both of these methods the trigger signal must be connected to the 7T11 External Trigger con-

ector. Operation is satisfactory at both low and high trigger repetition rates and when the repetition rate is not constant.

THEORY OF OPERATION RANDOM EQUIVALENT-TIME SAMPLING

Introduction

Random sampling permits display of the leading edge, or any other part, of the input signal shown in Fig. 3-13. This is possible even when observing fast-rise, short duration pulses, and when using either internal or external trigger sources (EXT modes of triggering give better results in Random Sampling).

Not only the input signal leading edge, but also vertical inputs prior to the arrival of the triggering signal can be displayed. An example is shown in Fig. 3-13, where the triggering is set for the (+) slope and at a triggering level above that of the first pulse. The pulse occurring prior to the trigger point is displayed.

Seeing before the triggering point is possible when using the 7T11 in Random mode due to the introduction of lead time. The effect of lead time is opposite to that produced by the Time Position control. Rotation of the Time Position control CCW increases the delay between trigger recognition (time T_0) and the start of the display window. Lead time, however, moves the display window in the opposite direction. The effect of lead time is evident if the position of the display window is compared in Fig. 3-12 and 3-13.

During Random mode operation, a lead time of approximately one-half the time positioning range (TPR) is introduced on all four equivalent-time sweep ranges. In addition,

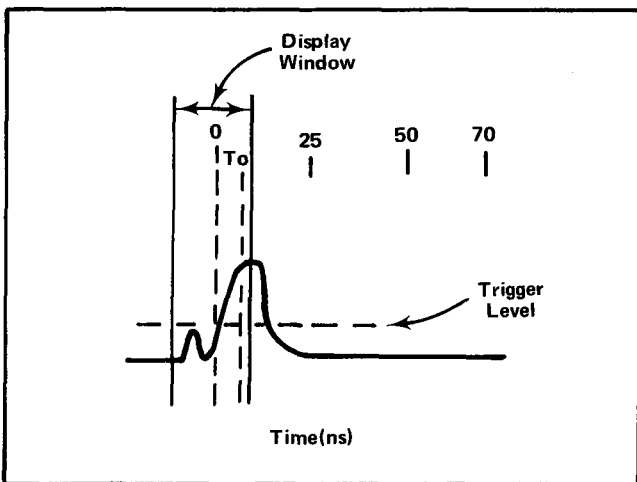

Fig. 3-13. Effect of lead time in moving display window.

on the 5 ns/div to 10 ps/div sweep range, an additional 50 ns of lead time is introduced. Since the TPR is 50 ns, at this sweep range setting, a total of (1/2 of 50 ns + 50 ns) approximately 75 ns of lead time is introduced at the fastest sweep range setting.

Lead time results from the action of the Ratemeter circuit and the introduction of offset current to the input of the Horizontal Amplifier. The direction of lead time offset current is opposite to offset current introduced by the Time Position control.

Random Mode Block Diagram

Comparison of Fig. 3-14 with the Sequential Block diagram of Fig. 3-8 shows that a number of blocks have been added. The additional blocks shown in Fig. 3-14 are: Ratemeter, Lead Time Offset, Ratemeter Correction, and Start Correction Memory. Another difference between between the Sequential and the Random block diagrams is that the Random block diagram shows a (+) stop input to the TTH, and an OR logic symbol is shown at the TTH input.

Ratemeter. The Ratemeter provides an output that permits the display window to include time prior to arrival of a signal at the sampling head as shown in Fig. 3-13. The Ratemeter effectively determines the time between triggers. Two Ratemeter inputs are needed to determine this time interval (see Fig. 3-14). These two inputs are a reset pulse delivered by the HOMV (at 1/2 hold-off interval after T_0), and an input delivered by the Trigger circuit at time T_0 . The Ratemeter effectively measures the time between reset and the next trigger recognition (T_0) and adds this time to the 1/2 hold-off time.

A third input to the Ratemeter is the DC correction. This input supplies the required lead time and correction to the timing of the Ratemeter output.

Lead Time Offset. The Leadtime Offset causes the Ratemeter output to occur approximately 1/2 time positioning range (1 1/2 TPR on the fastest Sweep Range) sooner than it normally would. This lead time permits strobe pulses to be delivered to the sampling heads before arrival of the signal to be observed and therefore permits seeing before the triggering point. The Lead Time Offset also provides an offset voltage to the Horizontal Amplifier so that trigger recognition (time T_0) is displayed at the approximate center of the display window.

Ratemeter Correction. The Ratemeter Correction circuit combines Lead Time Offset with the output of a comparator. This comparator is considered to be included in the Ratemeter Correction block of Fig. 3-14. The comparator delivers an output if the output of the TTH and the output

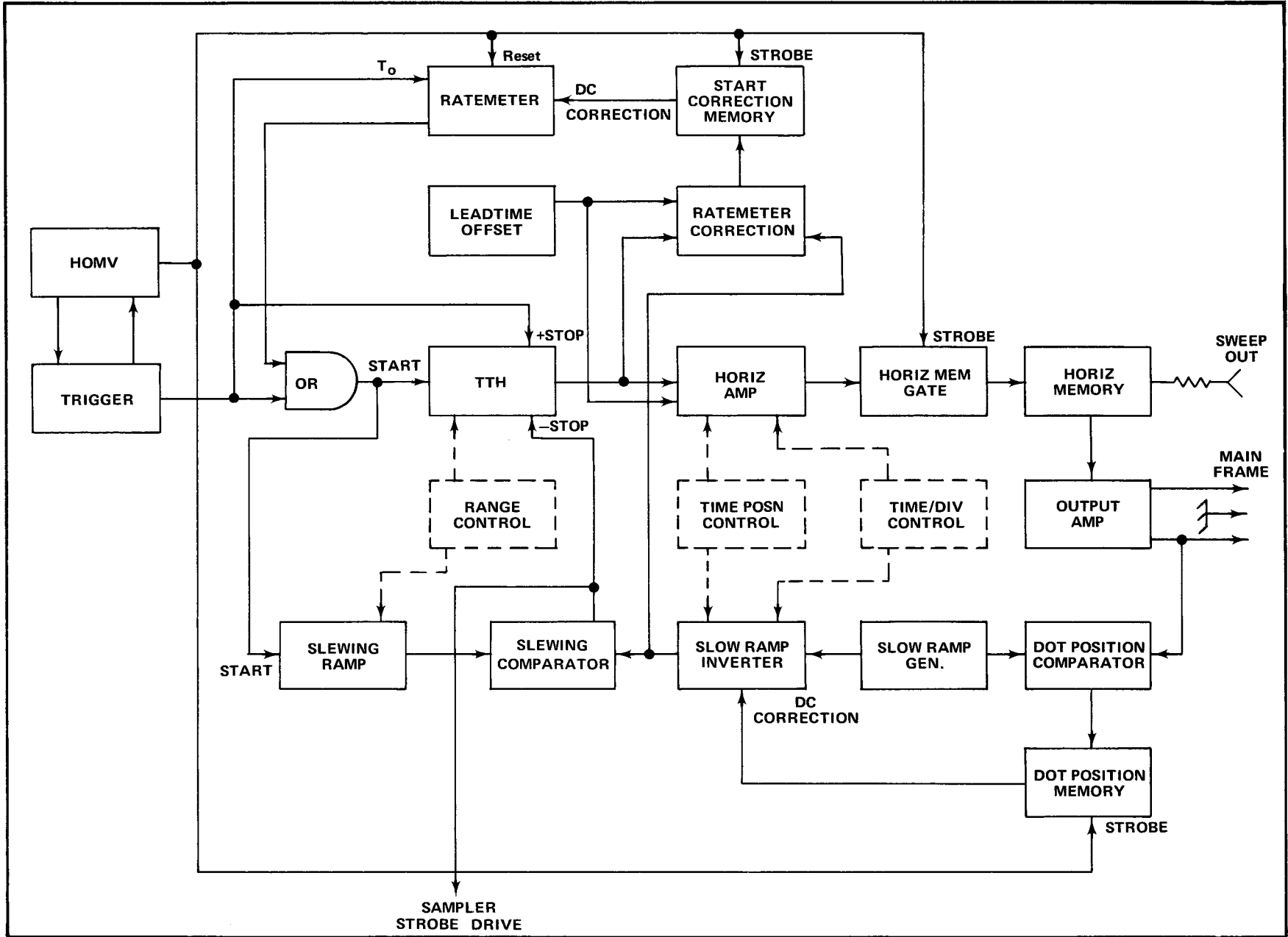

Fig. 3-14. Random mode block diagram.

Circuit Description—7T11

of the Slow Ramp Inverter are unequal. The error voltage from the comparator is combined with the Lead Time Offset at the Ratemeter Correction output.

Start Correction Memory. The Start Correction Memory includes a gating circuit. When the HOMV delivers a strobe pulse to this gating circuit, the output of the Ratemeter Correction circuit is stored in the Start Correction Memory. The Start Correction Memory delivers a DC voltage to the Ratemeter. This DC voltage provides Ratemeter lead time and assists in correcting any error in the timing of the Ratemeter output.

Random Operation

At a programmed time before the arrival of the trigger event, the Ratemeter produces a start command. The start command starts the Slewing Ramp. The Slewing Ramp and the Slow Ramp Inverter outputs are compared in the Slewing Comparator, which will deliver an output (strobe pulse) when the two ramps reach the same level. Although the TTH receives a start command from the Ratemeter at the same time as the Slewing Ramp, the TTH does not initially make any output excursion. The reason for no initial TTH output is that during Random operation the start command results in both a (+) input and an equal (–) input being applied at the same time to the TTH input. If the trigger arrives before the strobe, a (+) stop command occurs and the TTH runs negative until a strobe drive pulse and (–) stop command come from the Slewing Comparator. If the trigger and strobe events both happen simultaneously, the TTH produces no change in output voltage. If the strobe occurs before the trigger, then the TTH runs positive.

The start input to the TTH and Slewing blocks of Fig. 3-14 shows two inputs operating through an OR circuit. In normal Random operation, the Ratemeter produces a start drive pulse that precedes the trigger pulse. The incoming trigger pulse then has no more effect on the already started TTH and Slewing Ramp. In the event that the Ratemeter guesses much too late, or the period of an individual trigger is much shorter than the average period, then the trigger circuit will start the TTH and Slewing Ramp circuits, the same as in sequential.

Correction of the timing of the Ratemeter start commands results primarily from the use of (T_0) and HOMV (Reset) information fed to the Ratemeter. Because this correction is not adequate to make a start decision with the needed accuracy, the Start Correction Memory and DC correction circuits are added.

In the normal course of creating a CRT display, the strobe pulses are made to occur in a slewed manner over a window of time related to the trigger pulse. As the strob-

slew across the time window, the TTH produces different output levels corresponding to the different points in time.

The comparator (in the Ratemeter Correction block of Fig. 3-14) checks the output level of the TTH after it has been told to stop by both stop inputs. It compares this level plus a DC offset against the level of the Slow Ramp Inverter output. The comparator operating on the output of the TTH uses the slewing programming as a reference base; if the start commands are operating at the correct time with respect to the trigger, the comparator reads the same voltage at the TTH output as at the Slow Ramp Inverter (without leadtime offset). If the Slow Ramp Inverter has a –1 volt output, the TTH must have a –1 volt output. To obtain the earliest strobe possible after a start pulse has been received, the Slow Ramp Inverter output is set as close to zero as possible.

The DC offset provides the lead time correction needed to get the T_0 point (0 volts output from the TTH) shifted to the center of the screen with CW rotation of the Time Position controls. In order for this strobe to occur 1/2 a TPR ahead of the trigger, the start command must occur 1/2 a TPR ahead of the trigger. The TTH must be producing a voltage of +2.5 volts for the start (and the strobe) to be at this point ahead of the trigger. It is therefore necessary to add an offset voltage of 2.5 volts to balance out the difference in the comparator between the TTH and Slow Ramp Inverter outputs. To keep the Dot Position Servo content, it is also necessary to insert an offset into the input of the Horizontal Amplifier so that it thinks the TTH is putting out 0 volts instead of +2.5 volts. If the TTH output level agrees with the Slow Ramp Inverter output, then the start command was correctly timed and no shift in DC correction is needed. If the level is offset (+), the start was too early. Once the circuit decides that the correct starting time has been reached, the DC correction stops moving. The Dot Position servo then balances its comparator so that the dot ends up in the correct position on the screen.

Waveform Relationships During Random Sampling

Ideal waveform relationships during Random Sampling are shown in Fig. 3-15. The Triggering Level is set at the level indicated by the dotted line on the input signal waveform. Trigger recognition T_0 is occurring at 0 μ s, 25 μ s, 50 μ s, and so forth. Control settings are:

TIME POS RNG	5 μ s
SWEEP RANGE	.5 μ s/div to .1 ns/div
TIME/DIV	.5 μ s/div
TIME POSITION	fully CW

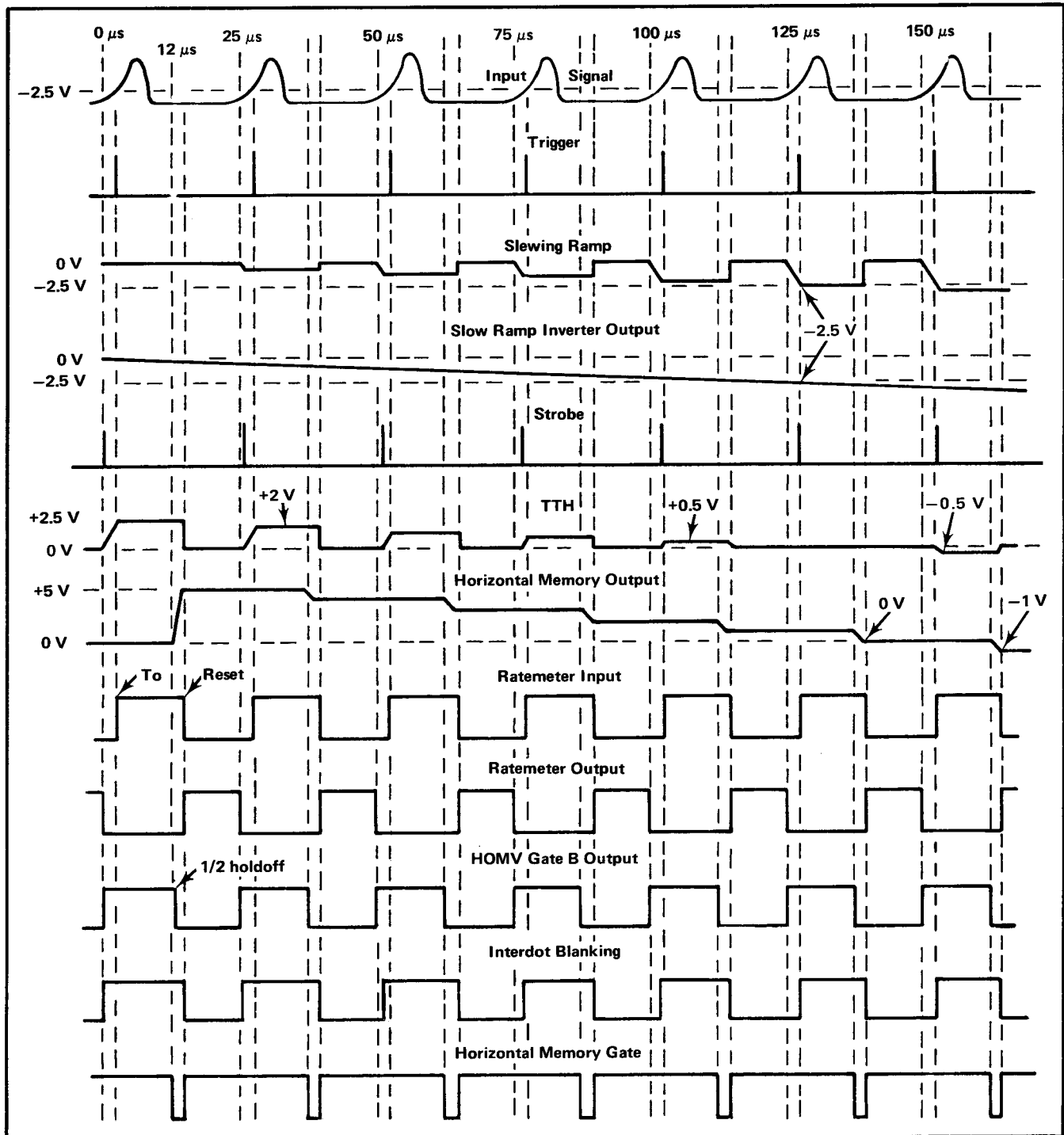

Fig. 3-15. Ideal waveform relationships during Random equivalent-time sampling.

Trigger repetition rate is constant and the Ratemeter is starting the Slewing Ramp $1/2$ TPR (time position range) or $2.5 \mu\text{s}$ before trigger recognition.

The waveform shown as the Ratemeter Input in Fig. 3-15 is at its higher level during the same interval of time

that the Trigger Output TD is at its higher level. When the Trigger Output TD goes to its high level at time T_0 , a positive-going pulse is fed to the T_0 Gate of the Ratemeter. When the Trigger Output TD switches back to its low level, the negative-going portion of the Ratemeter Input waveform causes reset of the Ratemeter. By effectively measuring the time interval between reset and the following T_0 ,

Circuit Description—7T11

the Ratemeter is able to predict when the next trigger will occur. A change in trigger repetition rate results in the Ratemeter changing the timing of its output pulse to ensure starting of the Slewing Ramp 1/2 TPR before trigger recognition. The Ratemeter Comparator and Correction Memory also assist in maintaining the relationship between Ratemeter Output and T_O .

In Fig. 3-15 the part of the vertical signal sampled by each strobe pulse is located vertically directly above each strobe pulse. The seven strobe pulses shown give a display of seven dots located one division apart horizontally (see Fig. 3-16). The sixth strobe pulse occurs at the same time as the trigger (at 125 μ s) and this sample is displayed 5 divisions from the left graticule edge. The triggering point is therefore displayed at the graticule center.

Using a slower SWEEP RANGE will provide more lead time (1/2 of time position range) and permit seeing further ahead of the trigger. The TIME/DIV control will still permit selecting the same or other sweep rates. Lack of space on Fig. 3-15 prevents showing the four additional strobe pulses required to fill the ten division display area.

The low dot density in Fig. 3-16 is a result of the unrealistic slope of the Slow Ramp Inverter Output waveform shown. The actual slope is determined by the SCAN control and is much more gradual than illustrated.

The input to the Horizontal Amplifier, in the example shown in Fig. 3-15, is identical to the TTH Output except for being offset -2.5 volts from that for the TTH.

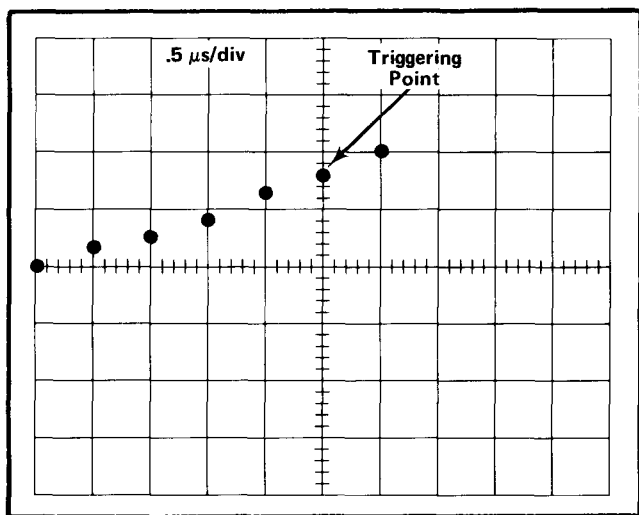

Fig. 3-16. Display of samples taken in Fig. 3-15.

When the fastest SWEEP RANGE setting is selected (5 ns/div to 10 ps/div) an additional 50 ns of lead time is automatically switched in. Adding this 50 ns to the 1/2 TPR (time positioning range is 50 ns at the fastest SWEEP RANGE setting) gives a total lead time of about 75 ns. With a lead time of 1 1/2 TPR (75 ns) the TTH is 7.5 volts more positive than the horizontal Amplifier input. Although it may appear that the vertical input is being sampled 75 ns before T_O , such is not the case. If, for example, 50 ns is required for the strobe pulse to travel to the sampling bridge, the first sample displayed is actually taken only 25 ns before T_O .

CIRCUIT ANALYSIS

During the following discussion of the 7T11 circuits, refer to the block diagram and the appropriate schematic at the rear of this manual. These diagrams, as well as the figures referred to in this section, will help in understanding the relationship between the various circuits.

Relationship Between the 7T11 and Vertical Unit

Fig. 3-17 shows the relationship between circuits in the 7T11 Sampling Sweep Unit and a 7S11 Sampling Unit located in the adjacent vertical compartment of a 7000-Series oscilloscope. Designations of RT are used on Fig. 3-17 to indicate switch positions during Real-time operation. ET indicates switch positions during Equivalent-time operation. Switching represented is actually done by transistors and diodes. The actual switching method used is discussed later in this section. The dotted lines in the vertical unit (labeled strobe, sampling drive, and oscillator control) are in use only during Equivalent-time operation.

In Fig. 3-17, switching is shown set to the RT (real-time) position. The 50 kHz Real Time Oscillator in the vertical unit is providing strobe pulses to the Memory Gate Driver in the vertical unit and to the Real Time Multivibrator in the 7T11. The strobe pulse to the Real Time Multivibrator is supplied by the adjacent 7S11 through the center conductor of a coaxial cable. Interconnection between units is via pin 14 of J641 (the connector mounted along the lower left side of the 7T11).

With the switches in Fig. 3-17 set to the ET (Equivalent Time) position, the Real Time Oscillator in the vertical unit is disabled and the Strobe Driver in the 7T11 supplies strobe pulses to the Memory Gate Driver of the vertical unit. During Equivalent Time sampling (either Sequential or Random) the 7T11 determines when the signal applied to the vertical unit is sampled. During Equivalent Time operation the Real Time Oscillator is disabled by effectively grounding the shield of the coaxial cable between the right-hand vertical plug-in and the 7T11. The Real Time Oscillator is disabled when the line labeled "oscillator control" is grounded.

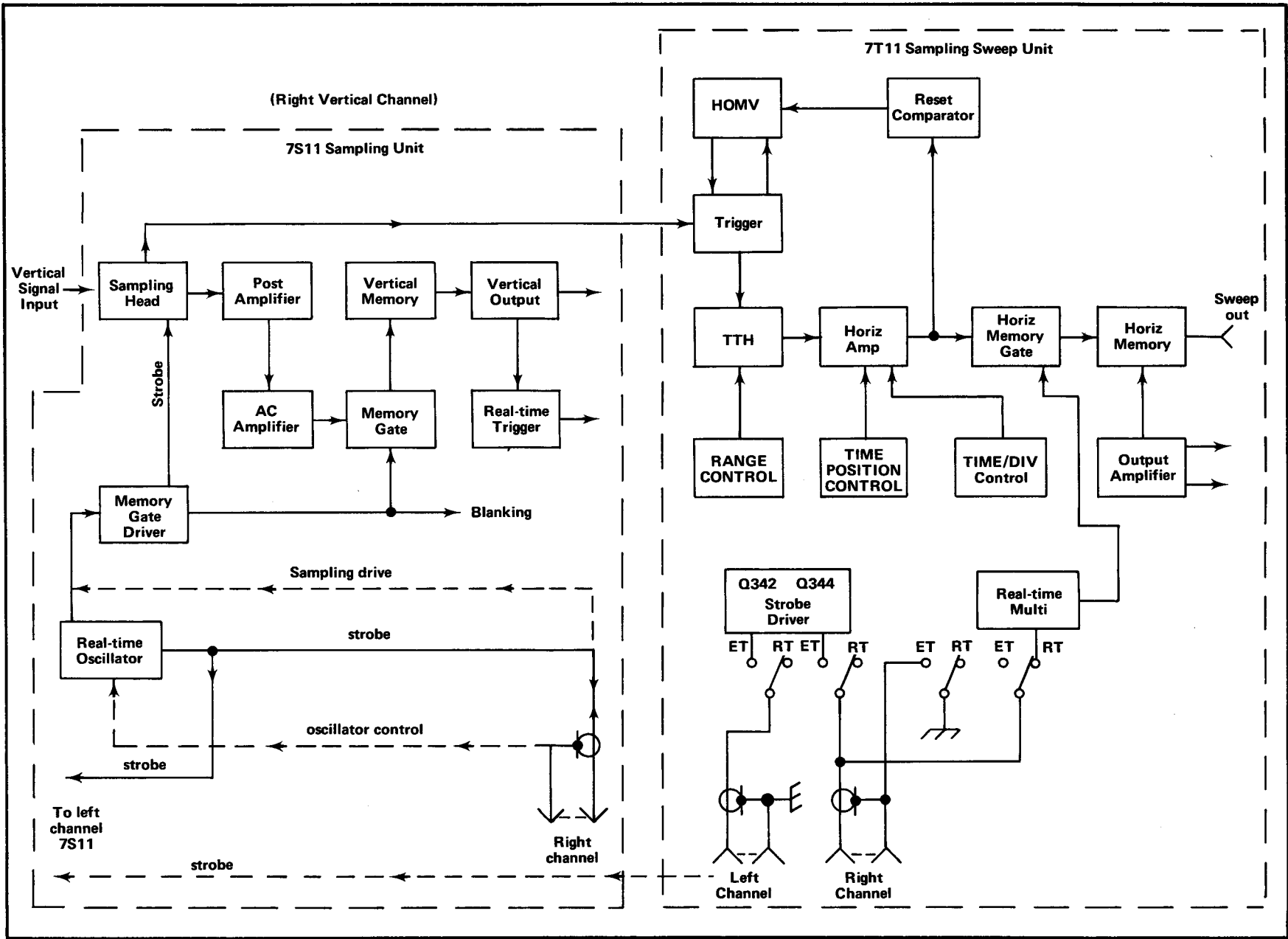

Fig. 3-17. Block diagram showing interconnections between 7T11 and vertical plug-in during real time operation.

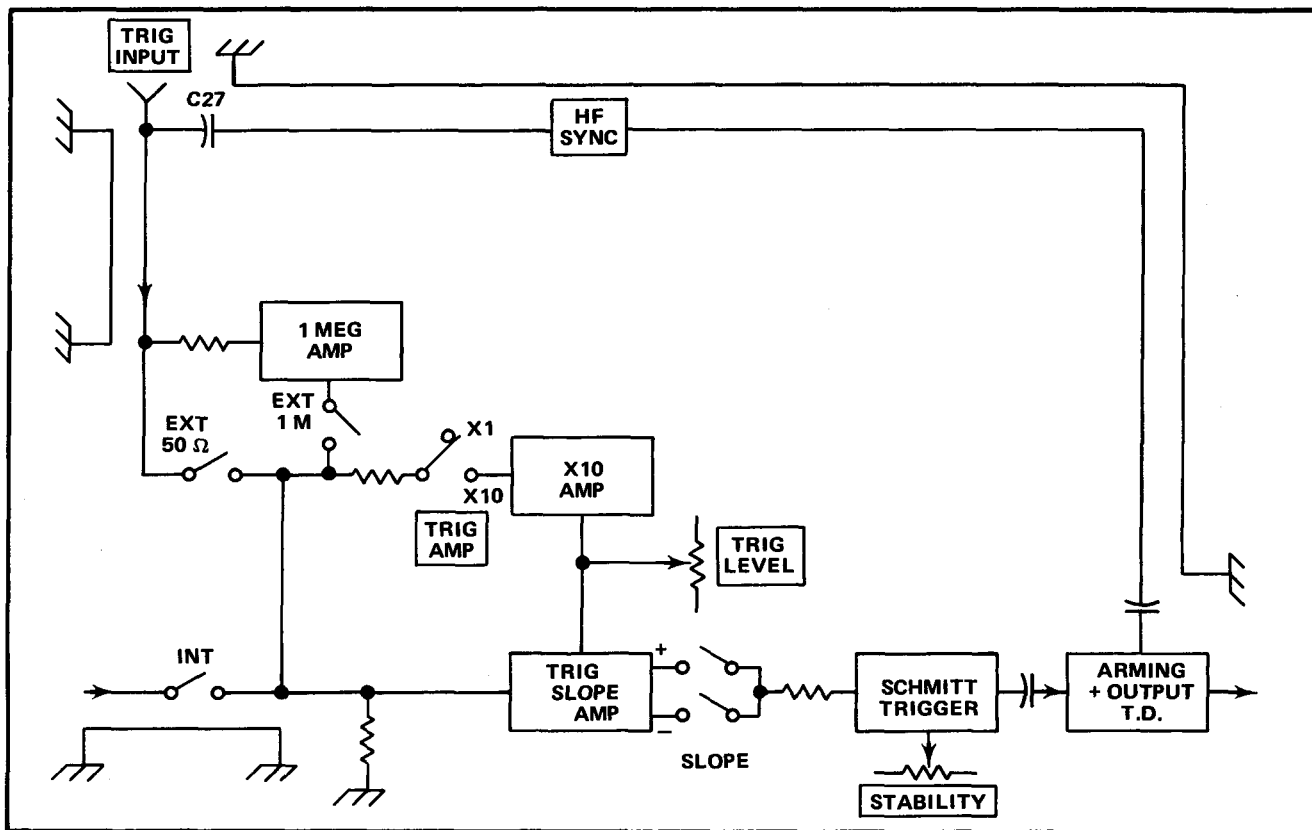

Fig. 3-18. Block diagram of the 7T11 trigger circuit.

The block in the 7S11 Sampling Unit (see Fig. 3-17), labeled Real Time Trigger, serves no purpose when using a Sampling Sweep Unit such as the 7T11. The Real Time Trigger circuit is for use with conventional time base units. See the 7S11 instruction manual for further information about this circuit.

Triggering Circuits

Fig. 3-18 is a block diagram of the complete trigger circuit. Four modes of triggering are available: Internal triggering from the signal applied to the sampling head of either vertical plug-in or one of three modes of external triggering can be selected. All triggering signals are carried by 50 Ω stripline or coaxial cable. Triggering signals do not go through front panel switches of the plug-in or the oscilloscope. Switching between different triggering modes is done by coaxially mounted reed relays controlled from the 7T11 front panel switches.

Triggering signals, except when the HF SYNC mode is selected, pass through the Trigger Slope Amplifier to the Schmitt Trigger circuit. The output of the Schmitt Trigger is fed to the Arming and Output tunnel diodes. The Output Tunnel Diode (CR152), if ready to recognize a trigger, provides a fast trigger signal to start the TTH ramp and the HOMV cycle.

The 1 Meg Amplifier shown in Fig. 3-18 is used only if the EXT 1M triggering mode is selected. The X10 Amplifier is available on all triggering modes except HF SYNC.

Internal Triggering

When internal triggering (INT) is selected, a portion of the input signal from either of the 7S11 plug-ins can be fed to the 7T11. This signal is carried between the adjacent vertical plug-in and the 7T11 through contact 2 or 8 of J641 (lower left side of the 7T11).

Within the 7T11 the triggering signal passes through the closed contact of the internal (INT) reed relay (see Fig. 3-18) to the Trigger Slope Amplifier (Q62 and Q72). The Trigger Slope Amplifier provides the proper polarity (positive-going) signal to the Schmitt Trigger circuit when triggering from either the positive-going or negative-going portion of the vertical input signal. When the Schmitt Trigger circuit fires, a fast rise pulse is coupled to the Arming and Output tunnel diodes.

With the INT pushbutton on the 7T11 pushed, the vertical unit (left or right) that supplies the triggering signal is selected by pressing its INT TRIG pushbutton. Fig. 3-19 is

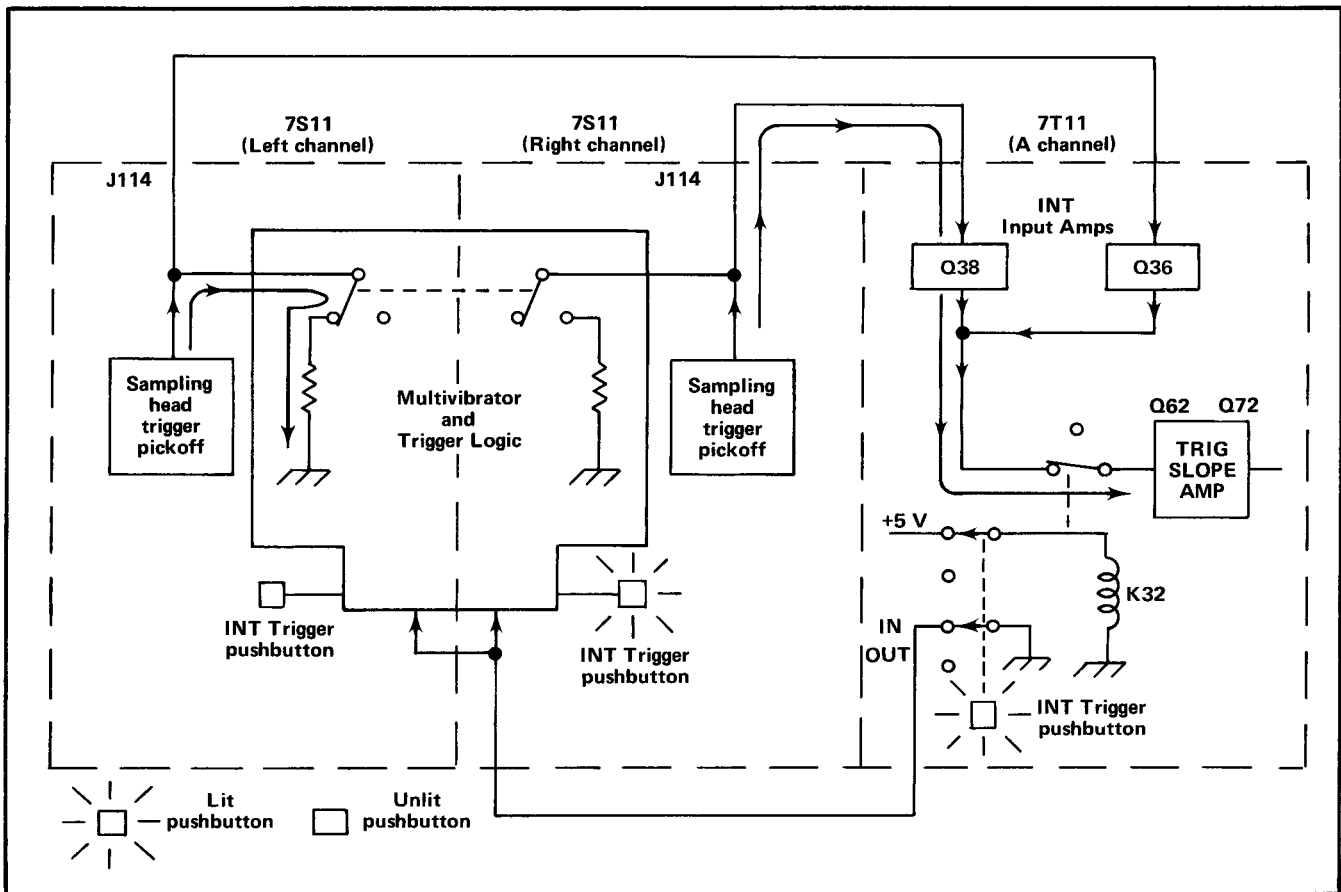

Fig. 3-19. Simplified 7T11 Trigger Selector circuit showing use of right channel 7S11 as source of internal trigger signal.

a simplified diagram of the circuits used to determine which vertical unit supplies the triggering signal. The figure shows a 7S11 Sampling Unit in both the right and left-hand vertical plug-in compartments of the oscilloscope. The 7S11 in the right-hand plug-in compartment is supplying the internal triggering signal to the 7T11. Which sampling unit supplies the 7T11 trigger depends upon the state of the multivibrator in the Multivibrator and Trigger Logic Block of Fig. 3-19. One-half of this multivibrator is in the left channel 7S11 and the other half is in the right channel 7S11. Although this simplified circuit represents the trigger logic circuit using a switch and resistor, the actual circuit utilizes transistors, diodes, and resistors.

In Fig. 3-19, triggering from the right channel has been selected and a portion of the input signal to this channel is applied, through Q38 and the closed contacts of the INT reed relay, to the Trigger Slope Amplifier (Q62 and Q72). Q62 and Q72 are shown on the Trigger Input schematic at the rear of this manual and are represented in block diagram form in Fig. 3-19.

In Fig. 3-19 the low resistance shunting the left channel trigger pickoff and the input of Q36 reduces the level of

this trigger signal below the level required to forward bias Q36. Pressing the INT trigger pushbutton on the left channel vertical plug-in causes the multivibrator to change state. The shunting resistance is removed from Q36 input and Q38 input is now shunted by a low value of resistance. The trigger signal picked off the left channel sampling head is now applied to the Trigger Slope Amplifier through Q36.

With the 7T11 INT trigger pushbutton pushed in, the coil of the reed relay (K32) is connected to +5 volts. Energizing this relay completes the circuit between the sampling head and the Trigger Slope Amplifier. The other set of contacts on the 7T11 INT trigger switch provides a ground to the multivibrator and trigger logic circuits in both 7S11 Sampling Units. Without this ground the INT trigger pushbuttons on the vertical units will not light, due to reverse biasing of their current sources. This reverse bias causes shunting of the trigger pickoffs of both sampling heads, preventing passage of trigger signals through either Q36 or Q38.

External (EXT 50 Ω) Triggering

When the 7T11 External 50 Ω input pushbutton is pushed in, trigger signals connected to the TRIG INPUT

Circuit Description—7T11

connector pass through contacts of the EXT 50 Ω reed relay (K31) to the Trigger Slope Amplifier. Refer to Fig. 3-18 and the Trigger Input schematic at the back of this manual. Selecting EXT 50 Ω provides a more direct and higher speed path than the INT or EXT (1 M) modes.

External (EXT 1 M) Triggering

When the EXT 1 M Ω pushbutton is pushed in, the 1 MEG AMP is inserted between the TRIG INPUT connector and the input of the Trigger Slope Amplifier. The 1 Meg Amplifier is a X1 gain, 1 megohm input FET amplifier. R42 provides the 1 megohm input impedance. Series limiting resistor R43 provides overload protection to the input of the amplifier for positive voltages. Diode CR43 provides overload protection against excessive negative input voltages. The 1 M ZERO adjustment (R45) is used to set the amplifier output to 0 VDC when no trigger signal is applied. Resistor R51 and C51 provide power supply decoupling while diode CR51 protects Q50 emitter-base junction against excessive reverse bias.

The trigger signal is applied to the gate of the A section of Q44. This signal appears at the drain of Q44 and is coupled to the B section of the FET through Q50. The signal appearing at the gate of Q44B is practically equal in amplitude to, and is the same polarity as, the signal applied to the gate of Q44A. Negative feedback appearing across the common source resistor R47 limits gain of the 1 MEG AMP to X1.

Trigger Slope Amplifier, SLOPE (–) or (+)

The Trigger Input schematic at the rear of this manual shows the Slope Amplifier connections with negative slope (–) selected. Q62 and Q72 are connected as a differential amplifier. With the TRIG LEVEL control set to mid-position, and no input trigger, current through each transistor is about 5 mA. Q72 current is delivered by the +5 volt supply through CR73, while Q62 current is supplied through R69. Current through R69 must be reduced below 5 mA to cause triggering of the Schmitt Trigger circuit. With (–) slope selected, this will occur when the base of Q62 is driven below the level on the base of Q72. With (+) slope selected, triggering will occur when the base of Q62 is driven above the level at the base of Q72. The level at the base of Q72 is determined by the setting of the TRIG LEVEL control. Triggering on either the positive-going or negative-going portion of the trigger signal can be selected using SLOPE switch S70.

Trigger Amplifier (TRIG AMP X1, X10)

The trigger line is connected to one input of the Slope Amplifier at all times. When the X10 pushbutton is pushed in, this same trigger line is also connected to the input of the X10 Amplifier. Q82 and Q92 form a high speed inver-

ting amplifier. The amplified and inverted output of this amplifier is fed to the other input of the Slope Amplifier, giving an effective boost to the gain, especially for trigger risetimes of greater than a few nanoseconds.

The input trigger is applied to the base of Q82A. The signal appearing across the emitter resistor R88 serves as the input signal to the B section of Q82. The in-phase signal developed across R87 is fed to the base of Q92. The inverted output signal appears across R96 and is coupled through C93 to the base of Q72. The amplified trigger signal appearing at the emitter of Q72 aids the unamplified signal at the base of Q62 and results in a X10 amplification of the trigger signal.

The X10 Zero adjustment (R80) is a calibration adjustment used to set the voltage at the output of the X10 Amplifier to 0 volts. Diodes CR91 and CR92 protect transistor Q92 against excessive reverse bias. Power supply decoupling is provided by R86 and C86. Decoupling filters are also used in the +5 and –15 volt supply lines.

Schmitt Trigger

The Schmitt trigger circuit used in the 7T11 provides a hysteresis band that can be made very narrow (around 1 millivolt) while retaining the use of a very fast, non-stabilizable tunnel diode. The tunnel diode is connected into a positive feedback circuit that does two things: It amplifies, by positive feedback, an input trigger signal; and once the tunnel diode has changed state in response to step trigger input, the circuit reduces current in the tunnel diode so that it will revert to the low state when the trigger step is removed. This circuit is disabled when the HF SYNC pushbutton is pushed in.

With the tunnel diode (CR134 in Fig. 3-20) armed and sensitive to small trigger input signals, current through the tunnel diode is just slightly below the value required for firing. The current through Q122 can be adjusted using the Trig Level Zero adjustment. Part of Q122 current flows through Q128 and the remainder through the series combination of the tunnel diode and Q138. An additional current is supplied to the series combination of the tunnel diode and Q138 through resistor R132.

Adjusting the Trig Level Zero permits the tunnel diode current to be set to just below the firing value (see point 1 on Fig. 3-21). A small positive-going trigger signal at the emitter of Q122 causes an increase of current. This increase in Q122 current flows through the tunnel diode and Q138. Even if this initial increase does not cause tunnel diode current to exceed the value designated as I_p , rapid firing of the tunnel diode may still occur due to amplification in the circuit. Any increase in tunnel diode current produces a change in voltage at Q138 collector. A part of this change

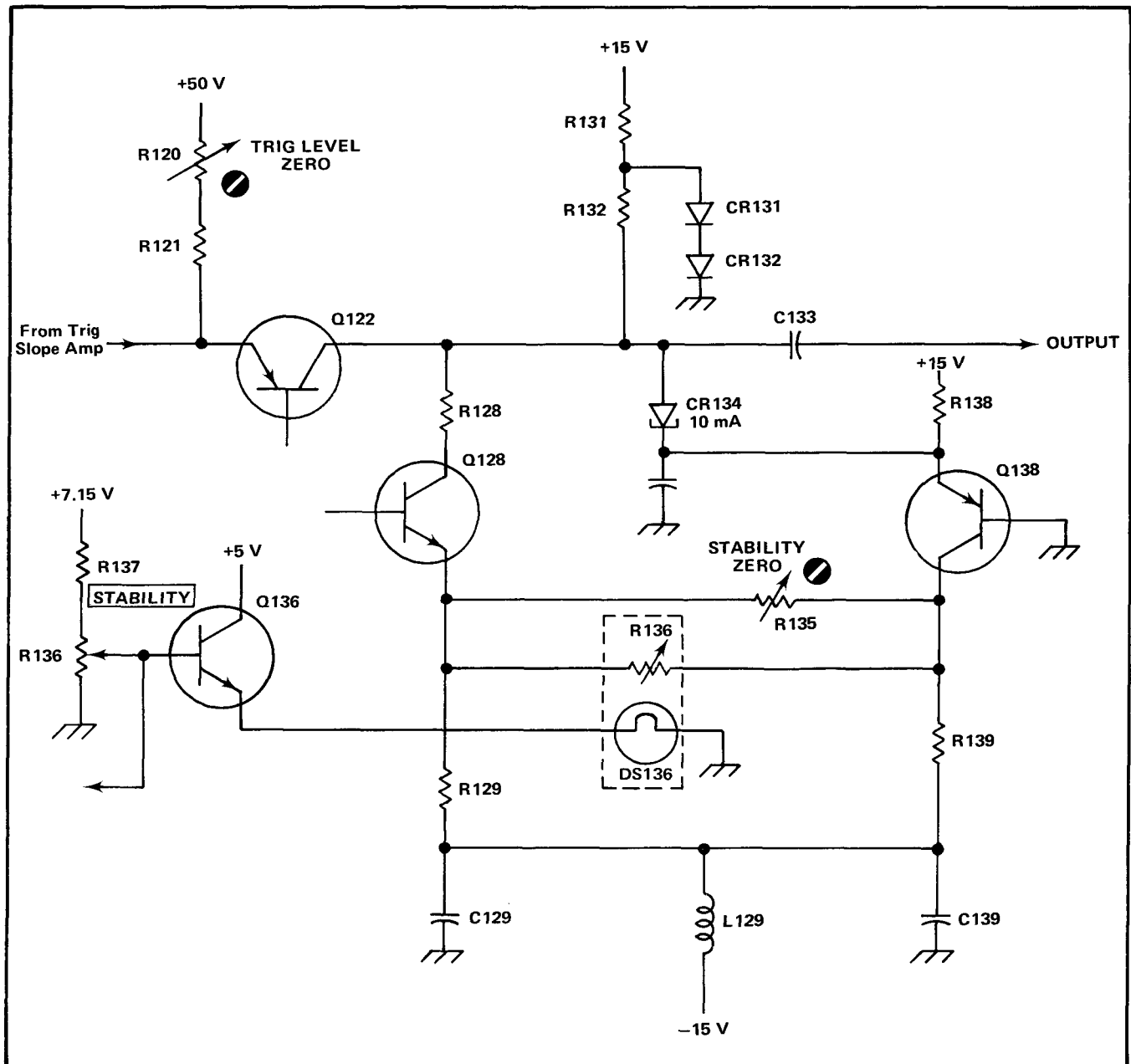

Fig. 3-20. Simplified schematic of the Schmitt Trigger circuit.

in voltage, as determined by the settings of the STAB ZERO and STABILITY controls, appears at the emitter of Q128 as a decrease in forward bias. This results in a larger percentage of Q122 current passing through the tunnel diode and Q138. If the initial increase in tunnel diode current plus the increase due to amplification result in tunnel diode current exceeding I_p , the tunnel diode will switch to point 2 on Fig. 3-21. Switching of the tunnel diode results in a loss of tunnel diode current because of the DC load supplied by R132. This loss of current is amplified by the circuit. The decrease in tunnel diode current causes an effect opposite to that produced by an increase in tunnel diode current. The forward bias of Q128 increases and a larger portion of Q122 current flows through Q128 causing

tunnel diode current to move from point 2 on Fig. 3-21 to point 3. With the tunnel diode current set to a value just greater than I_v , removal of the small triggering current causes the tunnel diode to switch back to the low voltage state shown as point 4. With the tunnel diode in the low voltage state, current is again supplied through R132 and tunnel diode current is again returned to the value indicated by point 1. The output of the Schmitt Trigger circuit is fed to the arming and output TD's CR142 and CR152.

The Stability control permits control of the sensitivity of the Schmitt trigger circuit. Gain of the amplifier is dependent upon the parallel resistance of the Stab Zero ad-

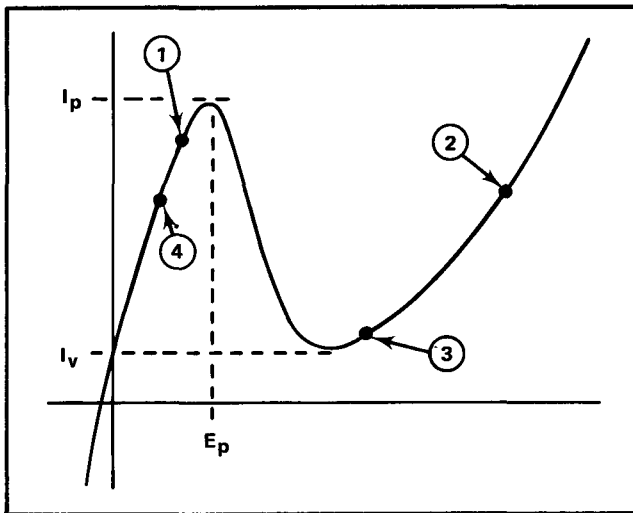

Fig. 3-21. Operating characteristics of Schmitt Trigger circuit tunnel diode (CR134).

adjustment R135 and the resistance of the photosensitive diode R136. Applying a more positive voltage from the Stability control to the base of Q136 increases the light output. An increase in light output reduces the resistance of the light sensitive resistor and increases the gain of amplifier Q128 and Q138. The Stability control receives regulated voltage from the μ A723 integrated circuit regulator through R137.

HF SYNC

When HF SYNC is selected, the Schmitt trigger circuit is disabled by applying a large forward bias to the base of Q128. A simplified diagram of the HF SYNC circuit is shown in Fig. 3-22. Important parts of the HF SYNC circuit are the integrated circuit (U20), a 200 MHz tunnel diode oscillator (CR28), and a 10 MHz tunnel diode (CR29).

Integrated circuit U20 (pin 4) supplies 7.15 volts as a stable source of voltage for the STABILITY and HF Sync controls. The integrated circuit also delivers a stable voltage of approximately +3 volts from pin 6 for use by the tunnel diode oscillator CR28. The voltage at pin 6 of the integrated circuit can be changed approximately $\pm 10\%$ by rotating the STABILITY control.

The 200 MHz oscillator (CR28) is synchronized to a sub-multiple of the incoming high-frequency trigger signals. The high-frequency sine-wave or pulse trigger signal, applied to the TRIG INPUT connector, is coupled to the 200 MHz oscillator through a coupling arrangement built into the trigger circuit board and through C27. The oscillator inductor L23 is the lead of tunnel diode CR28. Trigger signals, within a frequency range of approximately 1 to 12 GHz, are counted down to about 200 MHz by CR28. The

free-run frequency of CR28 is set during calibration, by means of screwdriver adjustment R10. The 7T11 STABILITY control permits the 200 MHz oscillator frequency to be varied about the value set by R10. The STABILITY control can be used as a coarse sync control during HF SYNC operation. Rotating the TRIG LEVEL control causes a slight change in the bias of the 200 MHz tunnel diode oscillator. During HF SYNC operation the TRIG LEVEL control functions as a fine sync control.

The output of CR28 is counted down by a factor of about 20 to 1 by 10 MHz tunnel diode oscillator CR29. Sync Countdown adjustment R30 is set during calibration and affects the bias and frequency of the 10 MHz tunnel diode oscillator. The approximate 10 MHz output of CR29 is fed through R34 to the Arming and Output tunnel diodes.

When the 7T11 HF SYNC pushbutton is in the out position both tunnel diode oscillators are disabled. The base of transistor Q26 is grounded through R26 causing Q26 to turn ON. Conduction of Q26 causes both Q22 and Q32 to turn ON. Conduction of Q22 disables the 200 MHz oscillator and Q32 disables the 10 MHz oscillator.

Pushing in the HF SYNC pushbutton removes the ground, applied through R26, from the base of Q26. With the HF SYNC selected the tunnel diode oscillators free-run except when a negative pulse is applied to the base of Q26 through R178. This negative pulse is applied when the Arming and Output tunnel diodes (CR142 and CR152 of Fig. 3-23) are at their high level.

Output triggers from the Sync Oscillator are coupled directly to the Arming and Output tunnel diodes CR142 and CR152 respectively.

Arming and Output Tunnel Diodes

Refer to Fig. 3-23 and to the Trigger and Hold-off schematic at the rear of this manual during the following discussion.

When the HF SYNC mode of triggering is selected the signal source for the Arming TD and Output TD is the HF SYNC Oscillator (tunnel diode CR29). Triggering energy is supplied through the right section of dual transistor Q140 to the Arming tunnel diode, and through R152 to the Output tunnel diode.

On any mode other than HF SYNC the Schmitt Trigger circuit supplies the triggering signal to the Arming and Output tunnel diodes. Triggering signals are supplied to the Arming TD through the left section of Q140 while the

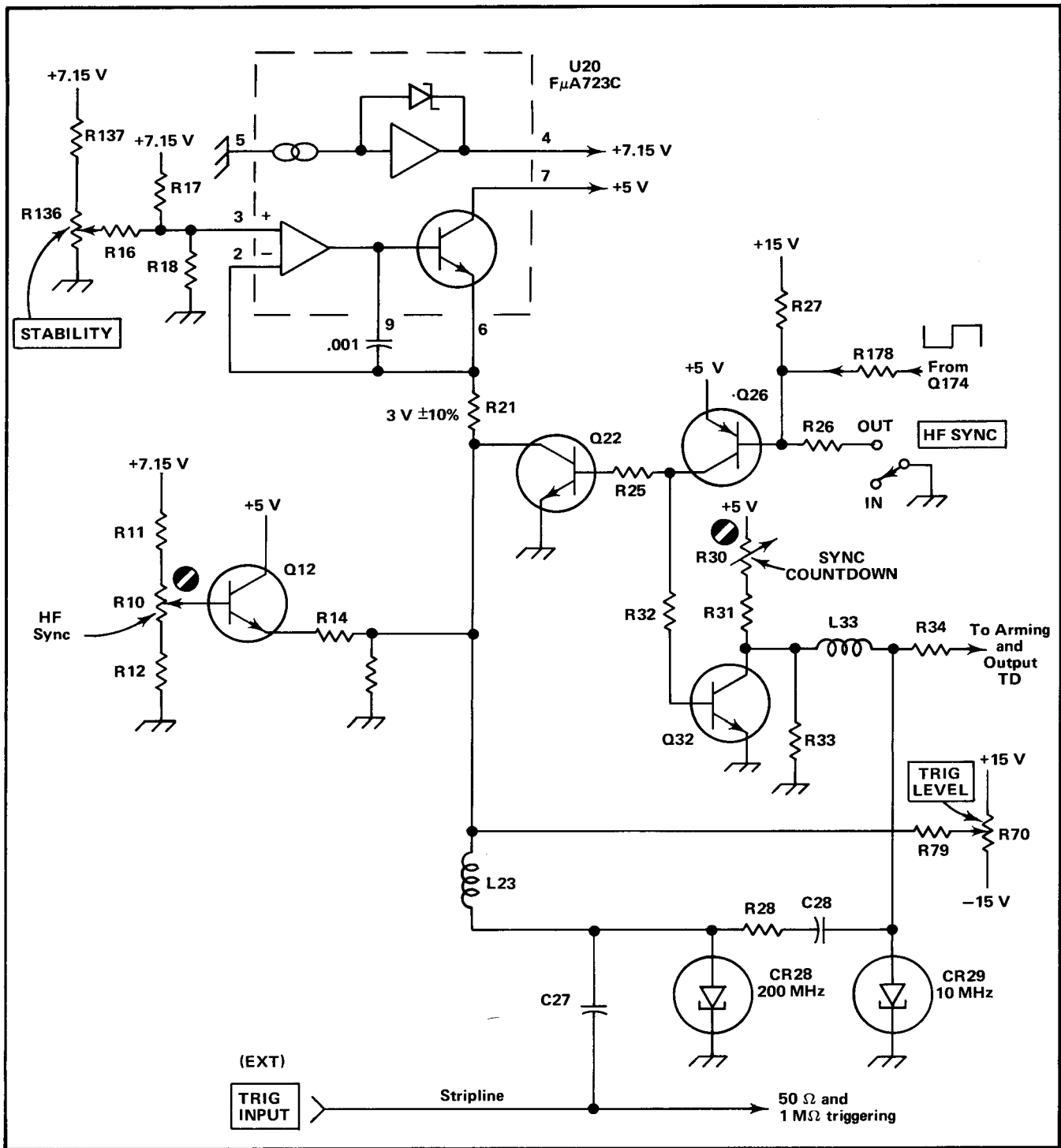

Fig. 3-22. Simplified diagram of HF SYNC circuit.

Output TD is supplied through R151 and a section of line providing a 5 ns delay.

provides output or controlling signals to a number of other circuits as shown in Fig. 3-23.

Output tunnel diode CR152 controls the state of the transistor differential pair (Q162 and Q164). This circuit

In order for a small trigger signal to switch the output tunnel diode to the high state, the arming and output tunnel diodes CR142 and CR152 respectively must first have

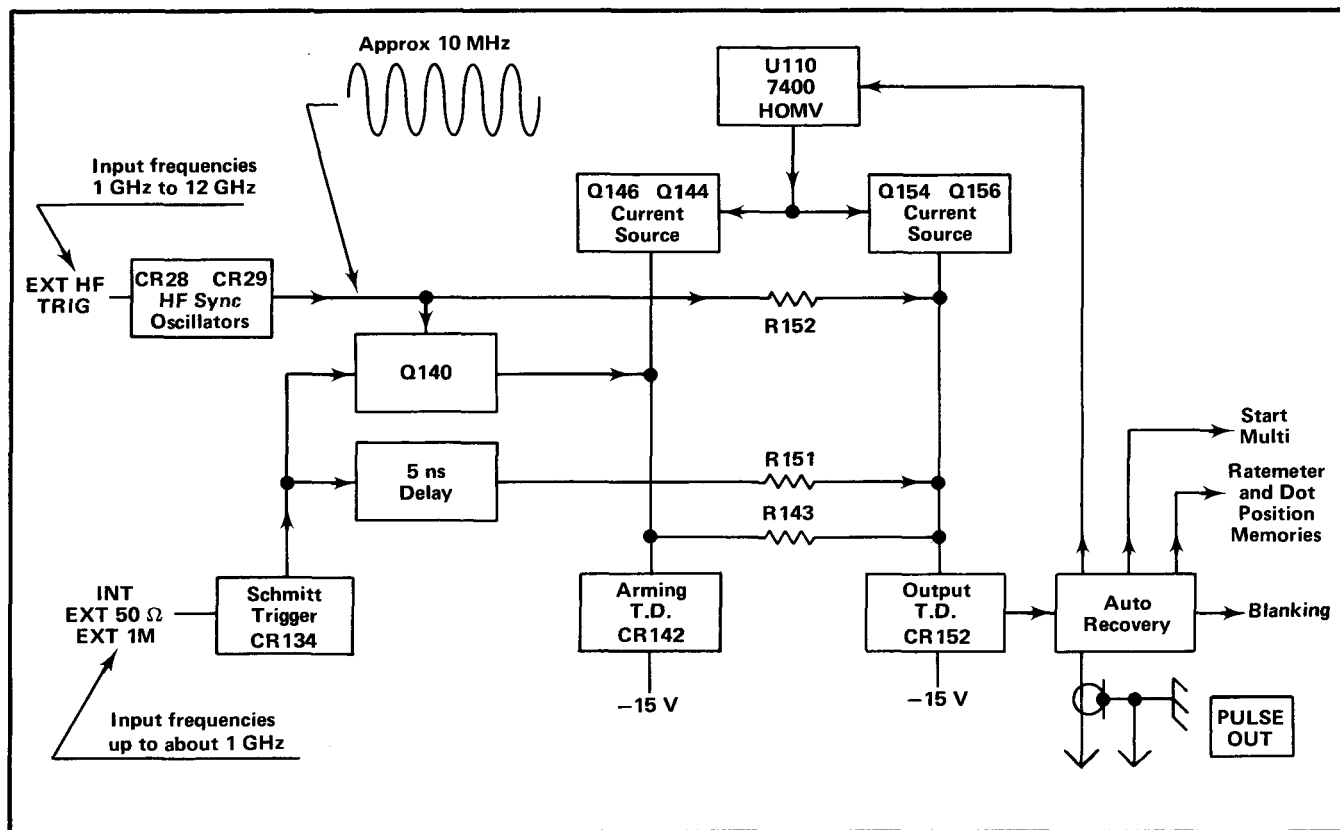

Fig. 3-23. Relationship of the Output Tunnel Diode to other 7T11 circuits.

sufficient arming current through them. Arming current for the arming tunnel diode is supplied by the differential amplifier consisting of Q146 and Q144. Transistors Q154 and Q156 are used in the differential amplifier serving as the current source for the output tunnel diode. The base of one transistor in each of the differential amplifiers is grounded (Q146 and Q156) while the voltage on the other bases (Q144 and Q154) is controlled by the HOMV (hold-off multivibrator).

When the output of Gate D of the HOMV (pin 11 of U110) is at approximately +4 volts, both Q144 and Q154 are shut off and neither tunnel diode can receive arming current. When the HOMV output switches to 0 volts the current sources for the tunnel diodes are turned on.

Current will increase to the armed value sooner in the output tunnel diode than in the arming tunnel diode due to a difference in the RC of components in the collector circuits. Providing the arming current is close to the armed value of CR142, the arrival of a trigger will switch CR142 to its high state. Switching CR142 to its high state increases the current through CR152 by about 3 mA. The output tunnel diode is now fully armed and will switch to its high state as soon as the trigger that switched CR142 reaches it through the 5 ns delay line.

Output T.D. Circuits

Refer to Fig. 3-23 and 3-24 as well as the Trigger and Hold-off schematic at the rear of this manual.

Trigger Pulse. When output tunnel diode CR152 is in the low state, current is flowing through transistor Q164 of the differential pair. When CR152 goes to the high state, Q164 shuts off and Q162 turns on. Turning on Q162 sends a fast current pulse to Q212 and thence to Q230 of the Start Multivibrator. The Start Multivibrator then starts the TTH Ramp.

HOMV Drive. When output tunnel diode CR152 goes to its high state Q164 turns off, which turns on Q174. This starts the Hold-off Multivibrator cycle. The voltage at the junction of R174 and R176 starts dropping at a rate determined by the parallel resistance of R174 and R176 and the capacitance of C101.

Pulse Out. When Q174 turns on, Q184 also turns on rapidly. This shuts off grounded base stage Q186, interrupting a 10 mA current. Interrupting this current produces a 1/2 volt, positive-going output pulse into 50 Ω. (The output pulse is 10 volts or more if the output is open circuited.)

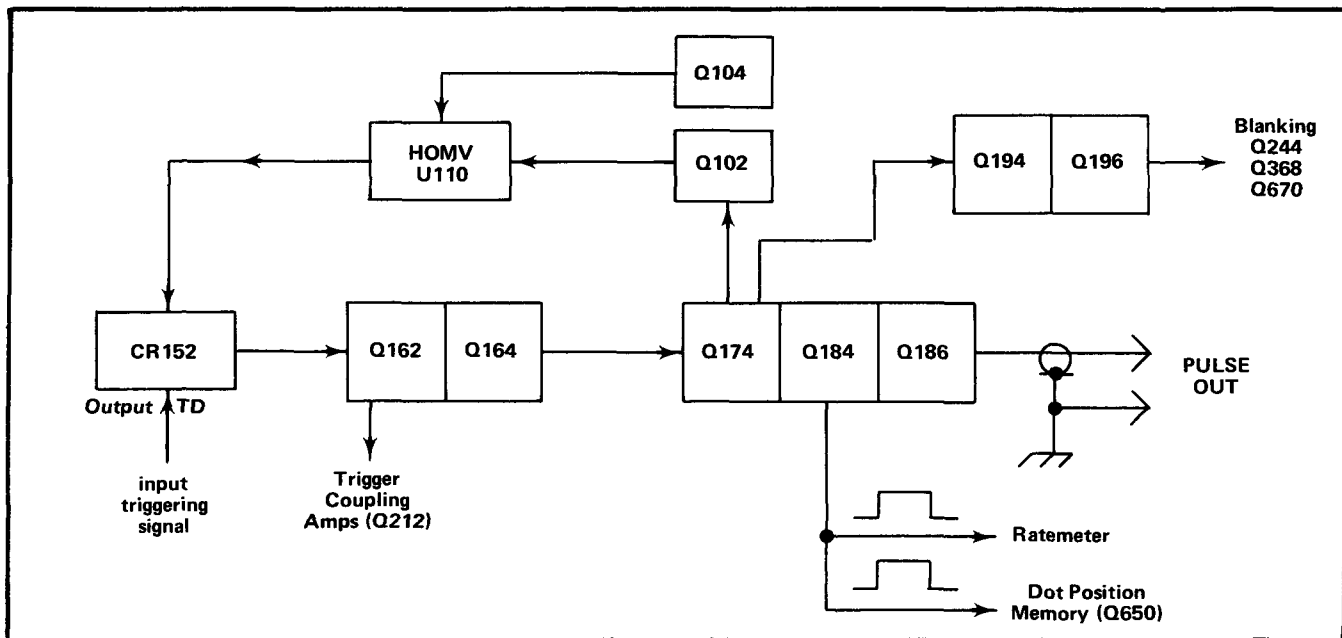

Fig. 3-24. Trigger Output Circuits.

Blanking Logic. No blanking is possible unless Q196 is turned on. Transistor Q196 will stay on as long as Q194 is shut off. Transistor Q194 is kept off by the peak detector (CR191, R191, C191, and R192) connected to its gate. Each time CR152 switches to its high level any slight loss in voltage on C191 is replaced. See Fig. 3-11 and discussion under the heading of Blanking in the Theory of Operation part of this section.

Real Time and Equivalent-Time Logic

The circuit providing Real-Time and Equivalent-Time Logic consists of diode CR807 and resistor R807 (see the Voltage Distribution and Decoupling schematic at the rear of this manual). This circuit provides an output voltage of +15 volts if the Sweep Range control is set to an equivalent-time position and an output voltage of -0.6 volts on real-time positions.

The output of the Real-Time/Equivalent-Time Logic circuit is used to enable or disable various circuits when changing from real-time to equivalent-time operation. The notation (+15 V ET, -0.6 V RT) is used on the schematics to indicate where the output of the logic circuit is applied.

Start Multivibrator

This circuit, formed by transistors Q230 and Q234, controls the start of the TTH and Slewing Ramps and provides logic for CRT blanking. See Fig. 3-25. Transistor Q234 supplies a 22 volt negative drive pulse to the gate of the switching FET (Q294) in the TTH, a 2/3 mA drive to the base of start transistor Q304 of the Slewing Ramp, and

Real-Time retrace blanking logic to Q244. The Slewing Ramp is used only during equivalent-time sampling.

Transistor Q230 receives drive from either the Trigger Circuit by way of grounded base stage Q216 or from the Ratemeter. The Ratemeter controls the Start Multivibrator only during Random sampling. The input from the Ratemeter is disabled in either Sequential Mode or the Real Time Sampling Mode by transistor Q222. Voltage at the junction of resistor R224 and capacitor C224 together with the voltage at Random-Sequential switch S220 ensure conduction of Q222 during both Real-Time and Sequential operation.

The bias on this MV is set so that both transistors shut off when no drive is applied to the base of Q230. The quiescent voltage at the collector of Q234 is -0.6 volt, as set by CR234 and R234. The network CR295, CR296, CR294, R296 and R294 ensures that the gate of the switching FET Q294 is never forward biased. The arrival of a drive signal causes the two transistors to conduct heavily, switching the collector of Q234 to -22 volts in about 15 nanoseconds. When the drive is removed, the transistors store for a microsecond or so, then shut off. The TTH transistor Q294 recovers first; the Slew Ramp is delayed slightly by the inclusion of the diode - RC network in the base. This diode decoupling network is necessary to keep the Slewing Ramp from receiving false restarts (with resultant double strobing) from reset aberrations present in the TTH.

Negative drive voltage of -22.5 volts is used for the FET gate because the TTH output can fall as low as -10 volts in normal operation. In order to ensure that the turn off bias

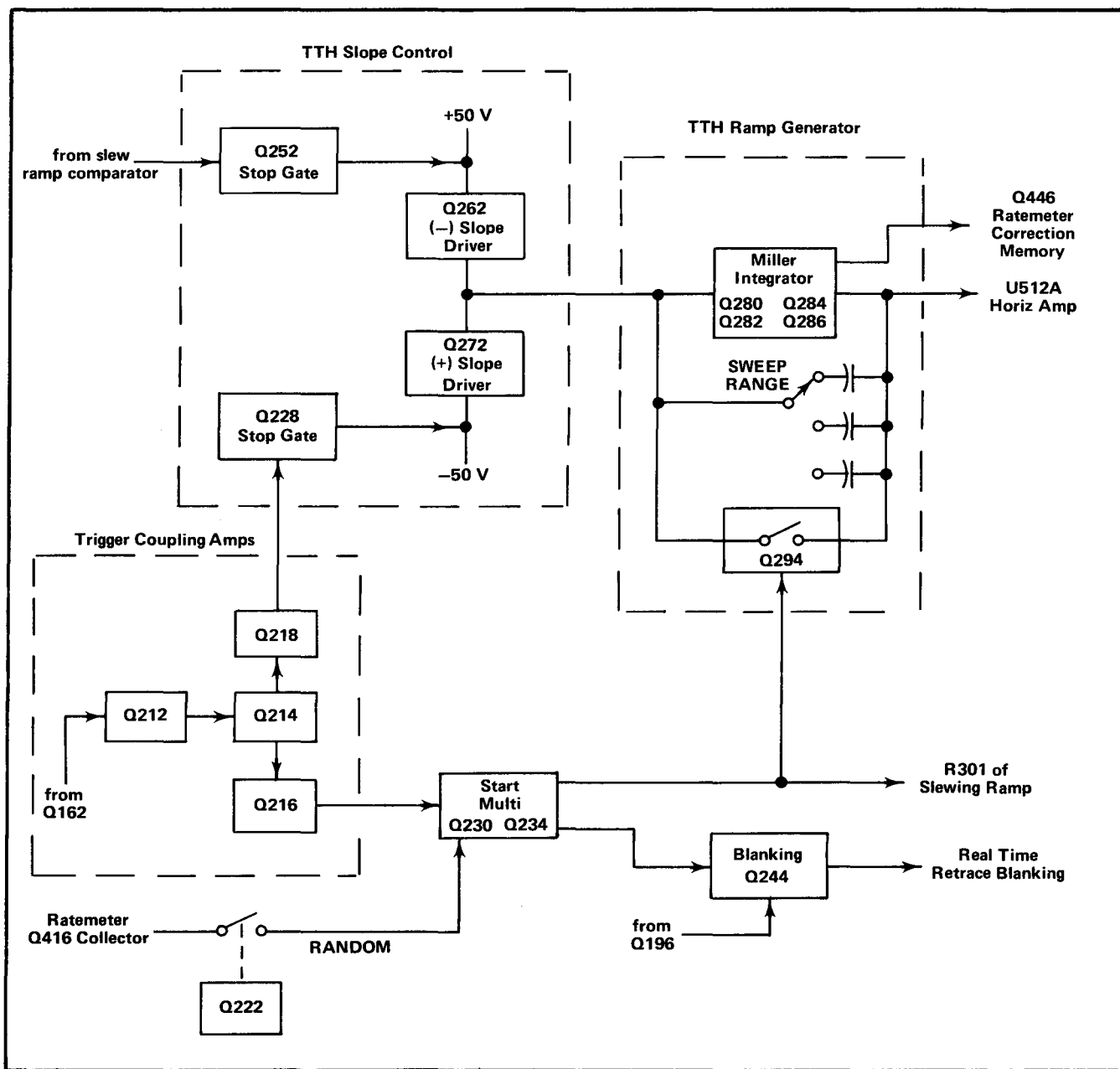

Fig. 3-25. Block diagram of circuits shown on TIME TO HEIGHT CONVERTER (TTH) schematic.

of the gate is always greater than pinch off, it must be set at a voltage much lower than the lowest allowable level of either the drain or source. C237 and C294 counteract and equalize the FET Gate blowby charge received during the start drive pulse. This blowby equalization is especially important when operating with the fastest range, where a 50 pF feedback capacitance is used. The ratio of gate-drain to feedback capacitance is large for this range.

TTH Circuit

The Time to Height Converter is the key timing circuit in the 7T11. It is essentially a Miller integrator formed by

transistors Q280 and Q284, and feedback capacitors switched by the Sweep Range control.

Fig. 3-25 shows two outputs from the TTH Ramp Generator. One output is fed to Q446 of the Ratemeter Correction Memory. The Ratemeter is used only during Random sampling and is discussed later in this section. The second output of the TTH is fed to U512A at the input of the Horizontal Amplifier.

The TTH output ramp may be made to run positive or negative with respect to its zero volt starting point. During

Real-Time and Sequential Sampling the TTH may only run negative. During Random Sampling the direction the TTH ramp runs depends upon whether strobe or trigger occurs first.

The direction that the TTH ramp runs is determined by the TTH Slope control circuits. See Fig. 3-25 and the TIME TO HEIGHT CONVERTER schematic at the rear of this manual. With Q262, the (–) Slope Driver, supplying input current to the Miller integrator the Miller output ramp will be negative-going. When the (+) Slope Driver Q272 supplies input current, the Miller output ramp is positive-going. Q262 and Q272 supply equal but opposite inputs. If both Q262 and Q272 are allowed to supply current to the feedback capacitors (C290, C291 and C292) the net result is no input and therefore no change at the Miller output.

To produce an output ramp, either Q262 or Q272 must be shut off. Conduction of Q252 will shut off (–) Slope Driver Q262, while conduction of Q228 will shut off (+) Slope Driver Q272. Another condition must be met if an output ramp is to be developed: Switching transistor Q294 must be shut off. When this transistor is ON, the input current is shorted around the feedback capacitors. Q294 provides a means of rapidly returning the Miller integrator output to the 0 volt level, thereby ending the TTH ramp.

When the output tunnel diode (CR152) switches to the high state, Q162 turns on. This turns on Q212 and results in a negative pulse at the collector of Q216 and Q218. This negative voltage level remains at the output of Q216 and Q218 until the output TD is switched back to its low level.

During Random operation the output of Q218 is used to drive Q228 into saturation. With Q228 saturated Q272 is reverse-biased. The (+) Slope drive to the Miller circuit is therefore cut off and remains cut off as long as the output TD remains at its high level. During Real Time and Sequential operation the output of Q218 has no effect on the (+) Slope Drive since the (+) Slope Driver is always off during these modes of operation. The same logic that causes Q222 to conduct, killing the Ratemeter input to the Start Multivibrator, also causes Q228 to remain on at all times during Real Time or Sequential operation. The voltage at the junction of R221 and R223 causes Q228 to saturate shutting off (+) Slope Driver Q272.

As mentioned previously the Start Multivibrator (Q230 and Q234) may be turned on by either of two signals. During Real Time and Sequential operation when Output TD (CR152) recognizes a trigger and switches to its high level, a negative pulse is delivered from the collector of Q216 to the base of Q230 causing both Q230 and Q234 to conduct. During Random operation the Ratemeter normally provides a negative pulse to the base of Q230 to turn

on the Start Multivibrator. However, in the event that a trigger does occur before the Ratemeter delivers a start signal to Q230, the Start Multivibrator will be turned on by the output of Q216.

When Q234 turns on, a negative pulse is developed at its collector. The negative pulse from Q234 is fed through CR244 to the Slewing Ramp and to the gate of Q294. The negative voltage applied to the gate of Q294 shuts off Q294, permitting the Miller circuit feedback capacitors to start charging.

Two timing current sources are available. The +50 volt supply and Q262 provide input current to drive the Miller output negative. The –50 volt supply and Q272 provide an input current in the opposite direction and cause a positive-going TTH output. Q272 is shut off when any of the three real-time ranges are selected and during sequential equivalent-time operation. Q272 is also shut off during Random operation by the output of Q218 at the time of trigger recognition.

The path for (–) Slope Drive current when developing a negative-going TTH output is shown in Fig. 3-26. Current through Q262 results in a negative-going TTH ramp at the output of the Miller circuit provided that Q294 has been shut off by the Start Multivibrator and (+) Slope Driver Q272 is also shut off. Current through Q262 is stopped by driving (–) Slope Stop transistor Q252 into saturation. This is done only during equivalent-time sampling. The (–) Stop signal is provided by the Slewing Ramp Comparator Q328.

Input current is 5 mA for all sweep Ranges except the two slowest; where it is switched to 50 μ A. The fastest ramp feedback capacitors are C291 and C292, and these are left across the Miller circuit at all times. Capacitor C292 is adjustable and is set during calibration. The next slower sweep range uses 450 pF, followed by 0.00495, 0.05, and 0.5 μ F. The 0.05 and 0.5 μ F are each used at two settings of the Sweep Range control; once for the two slowest sweep ranges when timing current is 50 μ A and again on the third and fourth positions of the Sweep Range control when timing current is 5 mA. Resistor R260 is used to set the timing current to 5 mA for the five fastest Sweep Ranges. On the two slowest ranges, when the path through R260 is opened, the timing current is set to 50 μ A by R265. An adjustment corresponding to R265 is not needed for Q272 since the three slowest ranges are for Real Time operation and Q272 never conducts on these ranges.

Fig. 3-27 shows the equivalent circuit of the Miller integrator used to develop the TTH ramp. The 10K resistor represents the resistance of R260, R261, Q262 and R264. The 50 pF feedback capacitor represents the capacitance of C291 and C292. At the fastest Sweep Range setting the

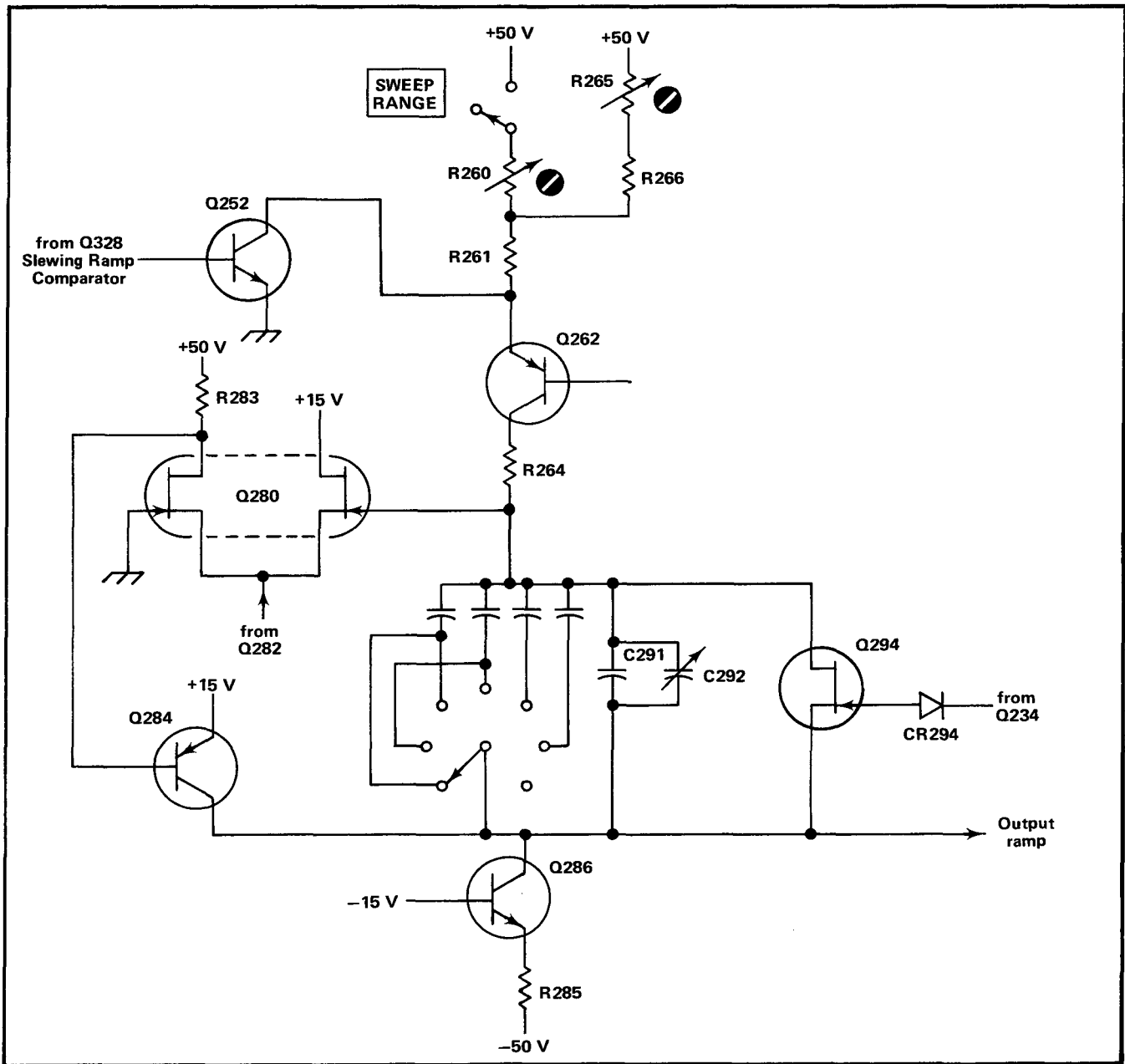

Fig. 3-26. Active portion of the TTH circuit when producing a negative-going output ramp.

feedback capacitor consists of C291 and C292 in parallel. The +50 volt supply is providing a 5 mA input current.

The TTH output voltage will theoretically change at a rate dependent upon the value of the feedback capacitor and the input current. The time (t) in seconds, for a given change in TTH output voltage, can be found from the following relationship:

$$t = \frac{CV}{I}$$

Where: t = time in seconds

C = value of feedback capacitance in farads

I = input current in amperes

V = change in TTH output voltage

At the fastest sweep rate the TTH output does not move fast enough to keep up with the amount of charge being delivered to it by the 5 mA current source. Without capacitor C264 this lag in the TTH output would result in a change in voltage at the TTH input and possible saturation of the input current sources. Capacitor C264 acts as a temporary charge storage device preventing the input of the TTH from moving until the amplifier circuit has had a chance to operate and transfer the charge from C264 into

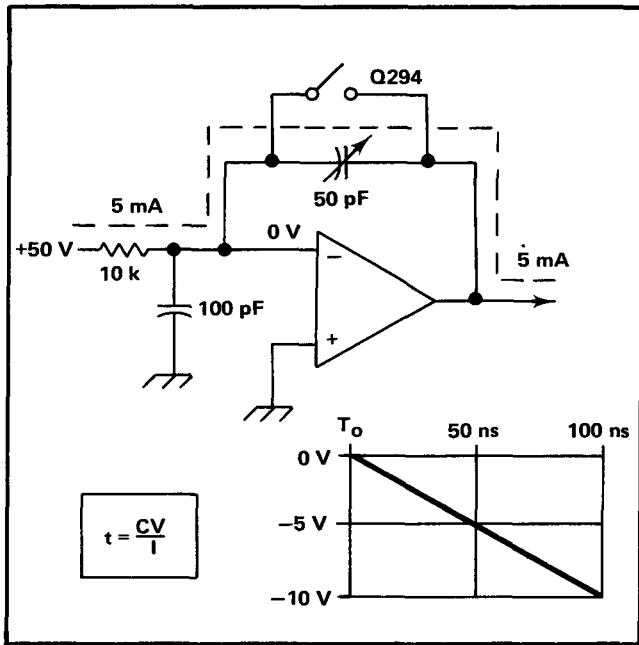

Fig. 3-27. Equivalent circuit of Miller Integrator used to generate TTH ramp.

the 50 pF feedback capacitor. After a period of time, but before the Horizontal Memory Gate pulse occurs, the TTH output level finally represents the amount of charge gated into its input between start and stop commands.

Horizontal Amplifier

Nine TIME/DIV settings are available at each of the seven positions of the Sweep Range control. The gain of the Horizontal Amplifier is determined by the setting of the TIME/DIV control. The Horizontal Amplifier gain is changed in a X1, X2.5, X5 sequence as the TIME/DIV control is rotated clockwise. See Table 3-1.

TABLE 3-1

Effect of TIME/DIV Control on Horizontal Amplifier Gain

TIME/DIV position	Gain provided by			Total Horizontal Amplifier Gain
	U512A	U512B	U512D	
CCW 1	X1	none	none	X1
2	X2.5	none	none	X2.5
3	X5	none	none	X5
4	X1	X10	none	X10
5	X2.5	X10	none	X25
6	X5	X10	none	X50
7	X1	X10	X10	X100
8	X2.5	X10	X10	X250
CW 9	X5	X10	X10	X500

An integrated circuit consisting of four operational amplifiers is used as the Horizontal Amplifier. The four stages of amplification are designated as U512A, U512B, U512D and U512C respectively on the schematic and block diagrams.

In the calibrated position, the first stage (U512A) provides a gain of X1, X2.5, or X5. This gain is set by R533, R534, or R536 together with R287. Resistors R535 and R537 are used to ensure that a 10 k impedance is seen looking from the output back to the input on the X2.5 and X5 gain positions. This ensures that the Variable control will provide the same variable ratio as provided on the X1 position. The input signal is inverted in passing through the first stage (U512A) of the Horizontal Amplifier.

Time positioning current is injected at the input of U512A to offset the dynamic range of the amplifier. See Fig. 3-28. Time positioning permits the Horizontal Amplifier to amplify different portions of the TTH output. The TIME POSITION control permits the start of the displayed sweep to be delayed after trigger recognition by an amount dependent upon the setting of the TIME POSITION control. The maximum time position current of 0.5 mA, with the control fully CCW, produces a 5 volt shift at the horizontal amplifier input. The TTH must now run down to -5 volts before being recognized as an input signal by the horizontal amplifier. The coarse control accounts for practically all of this current; the fine control has only a one percent effect.

On real time sweep ranges Real Time Zero adjustment R500 is operative. This adjustment permits the start of the real time sweep to be on screen, even in magnified positions of the Time/Div switch, by applying an offset current through R509. On equivalent time the Real Time Zero adjustment is disabled by applying +15 volts to the anode of CR502.

Two other paths for supplying the input of the Horizontal Amplifier with offset current are also shown on Fig. 3-28. Both of these paths are used only during random equivalent time sampling. When random sampling is used, a path for offset current is provided through Q506 and R509. The direction of this current is opposite that provided by the TIME POSITION control. This circuit therefore introduces lead time offset. For the 50 ns range, random mode, an additional offset current is provided through R507. This additional current provides the additional 50 nanoseconds of lead time needed for display of a triggering edge.

Transistors Q512, Q514 and Q524 serve as clampers and prevent driving the operational amplifiers of the horizontal amplifier into saturation.

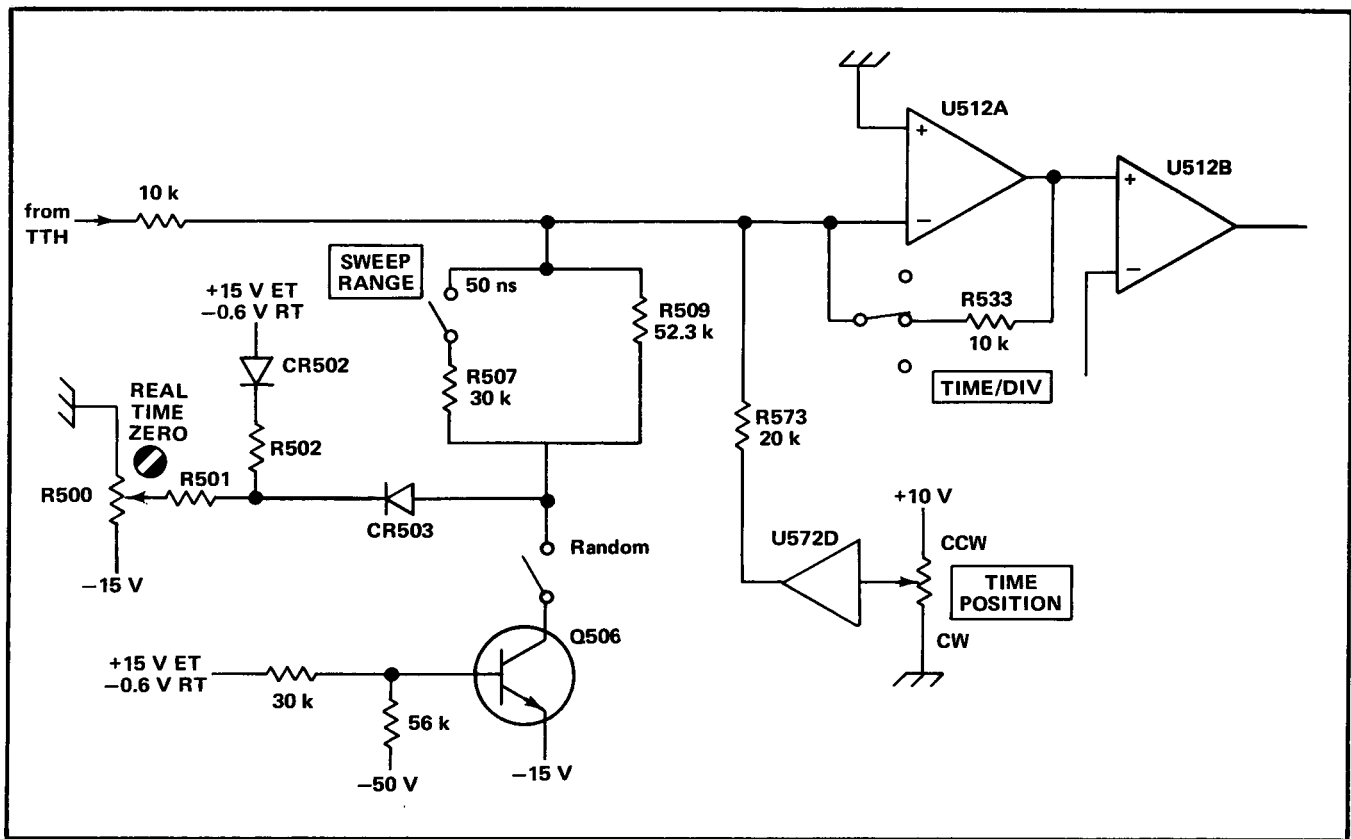

Fig. 3-28. Simplified diagram showing sources of Horizontal Amplifier offset current.

The second and third stages of amplification (U512B and U512D) each provide X10 gain when used. At a given setting of the Sweep Range control, the equivalent time sweep rate is directly proportional to the gain of the Horizontal Amplifier.

The last stage of the Horizontal Amplifier (U512C) provides a power gain. This stage must supply a maximum of 5 mA to the input of the Horizontal Memory and 2 mA to the HOMV reset circuit.

Real Time Multivibrator

See the SLEWING RAMP schematic at the rear of this manual. During real time sampling the Real Time Multivibrator provides a 3 μ s, positive-going drive pulse from the collector of Q362 to the emitter of Q546 at intervals of approximately 20 μ s. The Memory Gate Driver Q546 applies this positive pulse to the gate of Q556. This connects the input of the Horizontal Memory (Q560) to the output of the Horizontal Amplifier for the 3 μ s gating interval.

During real time sampling a positive-going 3 μ s duration pulse is also applied from the collector of Q362 through

R362 to the base of Q368. This enables Q368 and provides interdot blanking for a 3 μ s interval.

The Real Time Multivibrator consists of transistors Q352, Q356, and Q362. During real time operation transistor Q326 conducts, clamping Q328 so that no outputs come from this source. Also during real time operation the shield of the coaxial line to the right channel vertical unit is disconnected from ground by shutting off Q370. Removing the ground from the right channel coax shield permits the real time oscillator in the right channel sampler to function. See Fig. 3-17. This oscillator free-runs at about a 50 kHz rate and is frequency modulated at an approximate 200 Hz rate. The oscillator output is fed to the base of Q356 through CR348 and C348 as a series of positive pulses spaced at 20 μ s intervals.

When a trigger is received from the sampler, Q356 conducts, driving Q352, which drives Q356. Transistor Q362 also conducts, driving both the Horizontal Memory Gate and Interdot Blanking circuit. The feedback from Q352 to Q356 is through C358 and diode CR358. When the base side of C358 has charged to a negative level that shuts off Q356, transistors Q352 and Q362 are shut off. Resistor R357 provides a discharge path for C358, allowing the collector of Q352 to return to ground. The output of

the Real Time Multivibrator appears at the collector of Q362 as a 3 μ s positive pulse.

Horizontal Memory Gate Driver

The driver for the Horizontal Memory Gate is Q546. During real-time operation, the voltage applied to R543 and R541 drops to -0.6 volts. This voltage shuts off Q544 and saturates Q542. The base input of Q546 is now grounded and the emitter is not. The positive-going memory gating pulse, from the collector of Q362, is applied to the emitter of Q546 and is coupled through Q546 to the gate of Q556. In equivalent time, Q544 is saturated by the +15 volts applied to R543 during equivalent time operation. With Q544 saturated, the emitter input of Q546 is grounded. However, Q546 can still be turned on by applying a negative-going memory gating pulse from the HOMV to the base of Q546.

Transistor Q552 is a variable-gain amplifier used to correct memory offset caused by blowby of the gating signal applied to Q556. R547 ensures that some reverse bias still remains at the gate of Q556 with the positive going pulse applied.

An output is taken from the junction of R547 and R548 to drive the Start Correction Memory of the Ratemeter Servo. It is used only when operating in Random Equivalent Time.

Horizontal Memory and Gate

The Horizontal Memory is a Miller integrator similar to that used in the TTH. The feedback capacitor is C566. The input of the Miller is formed by the dual FET (Q560). The output of this differential amplifier is fed to the base of Q564. The signal appearing at the collector of Q564 is inverted from that applied to the input of Q560. Resistors R556 and R558 set the X2 gain of the Horizontal Memory. Resistor R557 shifts the output voltage swing of Q564 to +5 V to -5 V for inputs of 0 V to +5 V. Thus, both an inversion and a level shift is made.

The output level at the collector of Q564 is set by causing the Memory Gate Q556 to conduct. Q556 is gated on by turning on Q546. A positive-going memory drive pulse applied to the emitter of Q546 during real time sampling, or a negative-going pulse fed to the base of Q546 during equivalent time operation, will supply a positive pulse to the gate of Q556. With a positive gating pulse applied to Q556, the output of the Horizontal Drive Amplifier U512C is connected to the input of Q560; the output of the Memory is also connected to its input through R558.

During gate conduction time, C566 tends to slow down the response of the Horizontal Memory circuit. The

response is determined by the 100 ns RC time of C566 and R558. A 2 or 3 μ s wide memory gate drive pulse is used to insure 100% sampling efficiency. When the gate pulse ends and causes the FET gate to stop conducting, the Horizontal Amplifier and feedback resistor R558 are disconnected from the input. Memory capacitor C566 retains the final voltage reached by the amplifier until the next strobe occurs. Output of the Horizontal Memory is fed to the SWEEP OUT connector on the front panel and to integrated-circuit output amplifiers U672A and U672B.

Output Amplifiers

Two sections (U672A and U672B) of an integrated-circuit four section operational amplifier produce the push-pull signals for the oscilloscope drive. Drive requirements are 0.5 mA/div, push-pull, acting from the center of the screen. The amplifier, U672B, is a voltage follower with X1 gain and serves to amplify the Horizontal Memory output. Amplifier U672A inverts the information from the memory for the push-pull drive requirement. Both amplifier outputs are used for overrun blanking drive. The output of U672B is also used during equivalent time operation for Dot Position Comparator drive. The gain of the output amplifiers is adjusted by shunting some of the amplifier current around the load through R680. Horizontal positioning is done by using POSITION control R679.

While the output of U672B is changing from +5 volts to -5 volts, the output of U672A is changing from -5 volts to +5 volts. If the output of either section rises above +5 volts, Blanking Amplifier Q668 turns on Q670 (used for overrun blanking) thereby preventing a visible display of this portion of the sweep.

Hold-off Multivibrator (HOMV)

The HOMV is responsible for supplying signals at the proper time to several different circuits. Outputs to five different circuits are shown along the right side of Fig. 3-29.

The HOMV consists of four, two-input gates. The four sections are shown as A, B, C and D in Fig. 3-29. The four gates are divided into two sets. Each set is connected as a DC coupled multivibrator. The first set is formed using the gates designated A and B and having terminals 1, 2, 3, 4, 5 and 6. These two gates form the HOMV. The second set, consisting of gates C and D is used for Horizontal Memory Gate drive pulse logic and Real Time HOMV logic.

Each of the gates has the following characteristics: When both inputs are above +2 volts, the output is at 0 volts. Inputs to the gates will rise above +2 volts if the input circuit is opened. When one or the other input is pulled

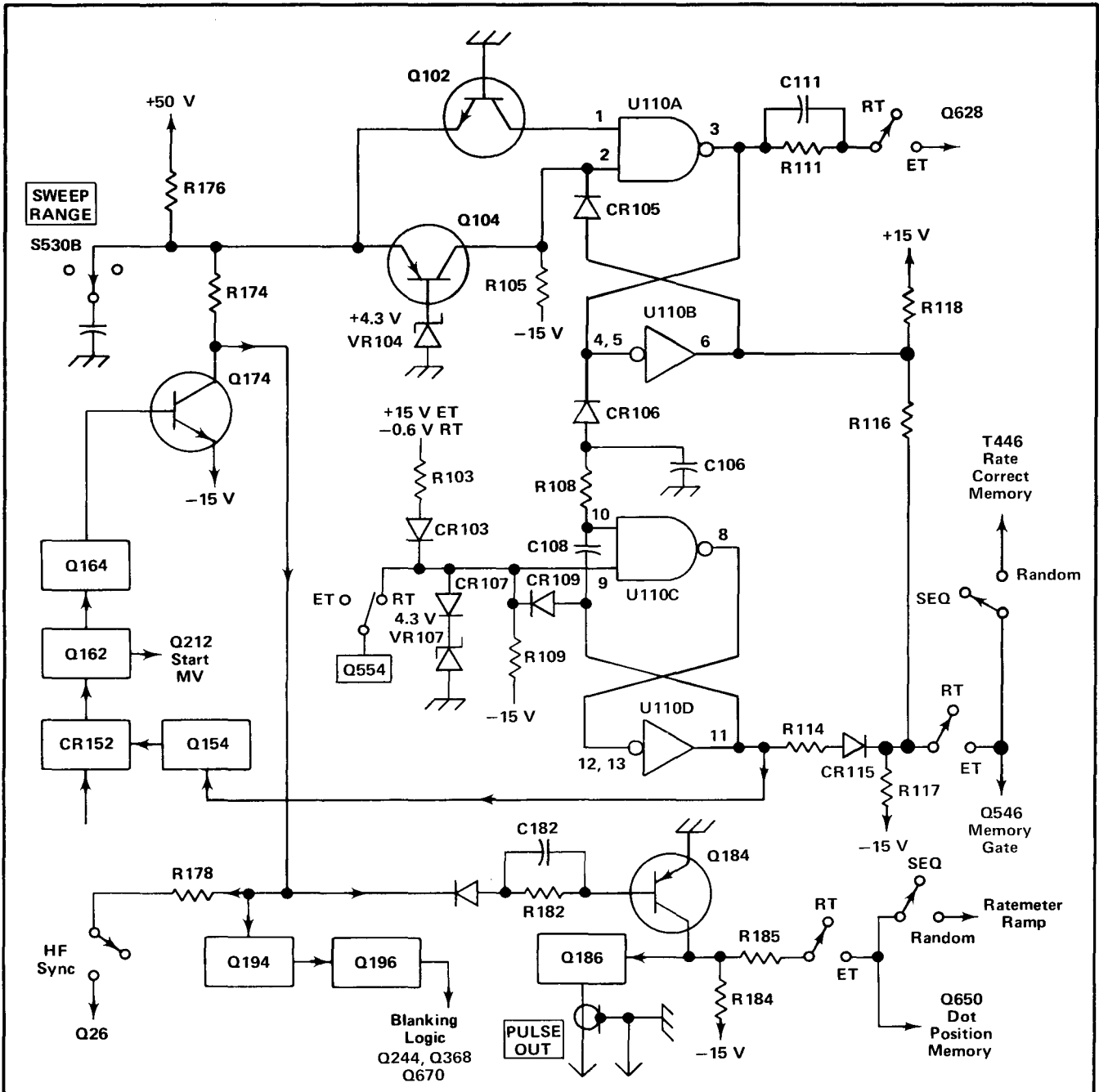

Fig. 3-29. Outputs of the HOMV and associated circuits.

below 0.8 volts with a current of 1 mA, the output goes to +4 volts. Since both inputs of Gates B and D are connected together these gates function as inverters.

The quiescent state of the gates is as follows: The output of Gate A is 0 volts, B is +4 volts, C is +4 volts, and D is 0 volts.

Inputs 1 and 2 of Gate A are both above +2 volts due to the positive voltage at the junction of R174 and R176. The

voltage at this junction reverse biases Q102 and forward biases Q104. With Q102 reverse biased input 1 is open and this input will pull itself up to a positive voltage. Input 2 is positive due to current through Q104 and R105.

The 0 volt output at pin 3 of Gate A is applied to inputs 4 and 5 of Gate B and results in +4 volts at the output (pin 6) of Gate B. Conduction of diode CR105 holds pin 2 positive when current through Q104 ceases shortly after trigger recognition (T_0).

The output of Gate C is also +4 volts. Pin 9 input of Gate C is above the +2 volt level if the equivalent-time mode is used and below the +0.8 volt level during real-time operation (note voltage at top of R103 in Fig. 3-29). Gate C output (pin 8) will be +4 volts however, when Gate A output is 0 volts, since pin 10 is kept below the +0.8 volt level by input current supplied through R108 and CR106. With Gate C output at +4 volts, the Gate D output (pin 11) is 0 volts.

The main difference in the action of the HOMV during real-time and equivalent-time operation is the manner and time at which sections C and D change state. During equivalent-time operation, pin 9 of the integrated circuit is held positive by voltage applied through R103 and CR103. All that is required to cause sections C and D to switch levels is to raise the voltage on pin 10 to about +2 volts. When Gate A output switches to +4 volts, diode CR106 is reverse biased, and pin 10 pulls itself positive at a rate determined by the RC of R108 and C106. When the voltage at pin 10 reaches approximately +2 volts the output of Gate C switches to 0 volts and causes Gate D output to switch to +4 volts.

During real-time operation, raising pin 10 to a positive potential may not change the state of Gates C and D, because a positive potential must be present at both Gate C inputs (pins 9 and 10). The positive voltage applied through R103 and CR103, during equivalent-time operation, is not present during real-time operation. The positive voltage required at pin 9 is supplied by reset transistor Q554. This reset pulse occurs when the output ramp of the Horizontal Amplifier reaches approximately +5.2 volts.

The interaction of the HOMV, trigger output tunnel diode, and sweep circuit is discussed below. Use of Fig. 3-29 and Fig. 3-30 together with the block diagram and schematic diagram at the rear of this manual will aid in understanding the time relationships of inputs and outputs of the real-time circuits. Time relationships during equivalent-time operation are covered later in this section.

Real-Time HOMV Switching. Assume that the TTH has recovered from the previous sweep and the Output TD (CR152) is armed and ready to be triggered. The arrival of a suitable triggering signal switches the Output TD to its high state, at a time designated as T_O on Fig. 3-30. This sends a negative-going pulse from Q162 to Q212. The Start Multivibrator then causes the TTH circuit to start a negative ramp output. Q162 also cuts off Q164, driving Q174 into conduction. The conduction of Q174 produces a negative output at the collector of Q174. This output is utilized in three places during real-time operation. Fig. 3-29 shows that this output is applied through R178 to the base of Q26 if HF Sync triggering is selected. This disables the HF Sync oscillator.

The signal at the collector of Q174 is also applied through Q194 to Q196. As explained earlier, none of the four types of blanking can produce blanking unless Q196 is turned on. Real-time retrace blanking is disabled at this time due to conduction of Q234 in the Start Multivibrator. Interdot blanking is not active at time T_O unless a strobe pulse happens to occur simultaneous with the switching of the trigger output tunnel diode to its high state.

The negative signal output of Q174 at T_O drives Q184 into conduction. The positive pulse appearing at the collector of Q184 is delivered, by way of Q186, to the PULSE OUT connector on the 7T11 front panel. The negative pulse at the collector of Q174 occurs when the output tunnel diode CR152 switches to its high state (at time T_O) and remains until CR152 is returned to its low state by an output from pin 11 of the HOMV.

Another output occurs as a result of the conduction of Q174 at time T_O . The voltage at the junction of R174 and R176 drops from +4.9 volts toward -5.3 volts at a rate determined by a hold-off capacitor switched in by the range switch. When the hold-off capacitor voltage reaches -0.6 volts, Q102 turns on, causing gates A and B to change state. When gates A and B change state, current through R105 and CR105 holds the gates in this state after removal of the negative voltage applied through Q102. This change in state of gates A and B occurs at a time referred to as 1/2 hold-off interval. Fig. 3-30 shows this occurring 1 ms after time T_O .

The switching of gates A and B at 1/2 hold-off interval causes the input current to pin 10 of gate C (through R108 and CR106) to stop due to reverse biasing of CR106. With input current stopped, pin 10 of gate C pulls itself positive at a rate determined by the RC at this input. When the voltage at pin 10 of gate C reaches approximately +1.5 volts, gate C switches provided its pin 9 input is also positive. As previously mentioned, pin 9 is kept positive at all times during equivalent time operation, but during real-time operation pin 9 is driven positive by Q554 when the output of the Horizontal Amplifier reaches about +5.2 volts. During real-time operation, Q554 usually drives pin 9 of gate C positive after pin 10 reaches the required +1.5 volts. With both pin 9 and pin 10 positive, gate C output switches to 0 volts, driving gate D output to +4 volts.

If the TIME POSITION control is set fully CW so that the Horizontal Amplifier ramp starts at the same time as the TTH ramp, and if a fast real-time sweep rate is selected, pin 9 of gate C will be driven positive by Q554 before pin 10 reaches +1.5 volts. Gate C will therefore not switch until C108 charges to the required +1.5 volts. The output of the Horizontal Amplifier will continue above +5.2 volts until limited by the dynamic range of the amplifier. Since overrun blanking permits a display of only the 0 to +5 volt portion of the Horizontal Amplifier output, no adverse effects result.

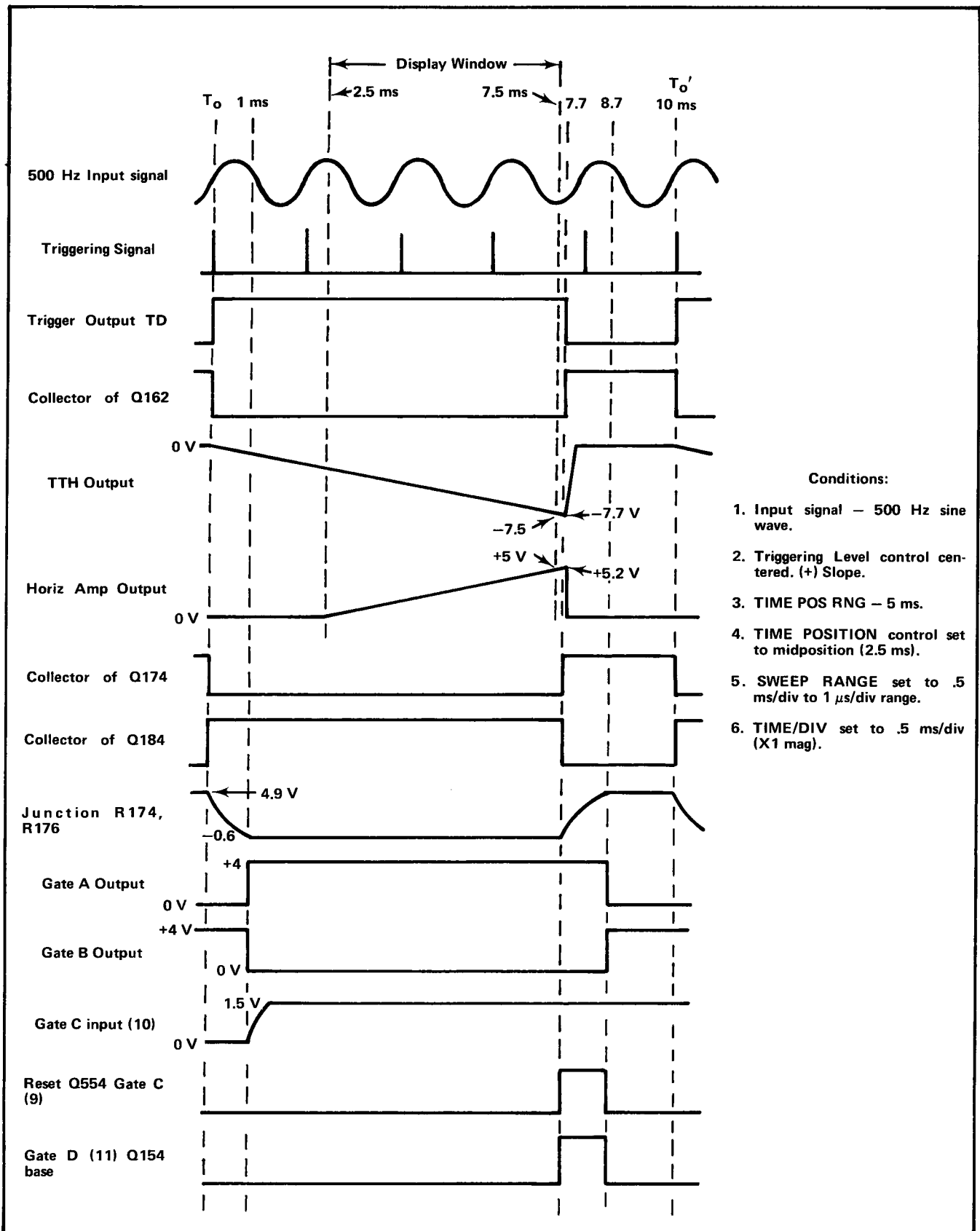

Fig. 3-30. Trigger, Sweep, and HOMV waveform relationships during real time sampling.

When gates C and D switch, a positive pulse is coupled to Q144 and Q154, the current sources for the arming TD (CR142) and the output TD (CR152) respectively. This causes both tunnel diodes to go to their low state. Q162 shuts off, causing the Start Multivibrator to shut off and end the TTH ramp and enable real-time retrace blanking. Q164 starts conducting, causing Q174 to shut off. The positive pulse at the PULSE OUT connector now ends.

When Q174 shuts off, the junction of R174 and R176 attempts to go to +50 volts but is prevented from doing so by the hold-off capacitor. When the charge on this capacitor reaches approximately +4.9 volts, transistor Q104 conducts, returning Gates A, B, C and D of the HOMV to their quiescent state. The arming and output tunnel diodes receive bias and the cycle is set for a repeat when another trigger is recognized.

Equivalent-Time HOMV Switching. The right side of Fig. 3-29 shows a total of five circuits receiving signals from switching of the HOMV during equivalent time sampling. The switching shown on Fig. 3-29 is actually done using transistors. Reference to Fig. 3-29 and Fig. 3-31 should help understand the time relationship between switching of the HOMV and activity in circuits receiving inputs from the HOMV. Fig. 3-31 shows waveform relationships during sequential equivalent-time sampling. The same basic time relationships exist during Random sampling except for the influence of the Ratemeter circuits and lead time offset current on sweep related circuits. Comparison of Fig. 3-15 with Fig. 3-31 shows that the same basic time relationships hold between the HOMV, Trigger, and blanking circuits.

The output levels of the four gates, just prior to trigger recognition, is the same as listed for Real-Time HOMV operation. Output of Gate A is 0 volts, B is +4 volts, C is +4 volts, and gate D is 0 volts.

When the Output TD in the trigger circuit fires, Q174 conducts. Q184 also conducts, producing a pulse output drive and a drive pulse to the Ratemeter T_0 memory level. Conduction of Q174 results in the voltage at the junction of R174 and R176 dropping from +4.9 volts toward -5.3 volts at a rate determined by the hold-off capacitor switched in by the Sweep Range switch. When the capacitor voltage reaches -0.6 volts, Q102 turns on, causing A and B gates to change state. This is shown occurring 10 μ s after time T_0 in Fig. 3-31.

When Gate B goes from +4 volts to 0 volts, part of this change in voltage appears at the junction of R116 and R117. Fig. 3-29 shows that this negative pulse is applied to the base of Q546 (Horizontal Memory Gate circuit) as a conduction command during equivalent-time sampling.

The switching of Gate A output from 0 volts to +4 volts shuts off input current to pin 10 of Gate C due to reverse biasing of CR106. Within about 2 μ s the voltage at pin 10 of Gate C (see Fig. 3-31) rises to the approximate +1.5 volts required to cause switching of Gates C and D. The requirement that both Gate inputs be positive to get a low output is met since pin 9 is also positive. Fig. 3-29 shows that during equivalent-time operation a positive voltage is supplied to pin 9 through R106 and CR106.

Switching of Gate D output to +4 volts is shown in Fig. 3-31 at approximately 12 μ s after T_0 . This positive output from Gate D ends the Memory Gating pulse. At the same time Gate D output shuts off current sources Q144 and Q154 causing the Arming and Output TD's to switch to their low state. With Output TD (CR152) at its low state, conduction of Q174 stops (12 μ s after T_0 in Fig. 3-31).

When Q174 shuts off, Q184 also shuts off causing the pulse at the Pulse Out connector to end. A negative-going pulse is fed from the collector of Q184 through R185 to gate the Dot Position Memory during equivalent-time operation and to Q404 to reset the Ratemeter Ramp.

When Q174 shuts off (12 μ s after T_0 in Fig. 3-31) the hold-off capacitor connected to the junction of R174 and R176 starts charging toward +50 volts. When the voltage at the junction of these resistors is approximately 0.6 volts more positive than the 4.3 volts maintained at the base of Q104 by zener VR104, Q104 will turn on. The pin 1 input of Gate A has pulled itself positive since Q102 conducted only momentarily at the 1/2 hold-off interval (10 μ s to 12 μ s in Fig. 3-31) when gates A and B switched. The pin 2 input has been held down by the input current supplied through R105.

As soon as the emitter of Q104 reaches +4.9 volts the current through R105 switches to Q104 and pin 2 of gate A pulls itself positive causing all gates to switch back to their original quiescent level. The current sources Q144 and Q154 for the Arming and Output tunnel diodes are turned on by the output of gate D and all circuits are again ready for the next trigger.

Slewing Ramp

The switching of Output TD (CR152) to its high level causes the output of Q162 to go negative. The negative-going output of Q162 is fed to Q212, which results in a negative-going output from Q234 of the Start Multivibrator. The negative pulse produced at the collector of Q234 starts both the TTH and Slew Ramps. Both of these ramps run at the same rate. The rate of change of the ramp voltage is dependent upon the setting of the SWEEP RANGE control. Refer to the Slewing Ramp schematic at the rear of this manual.

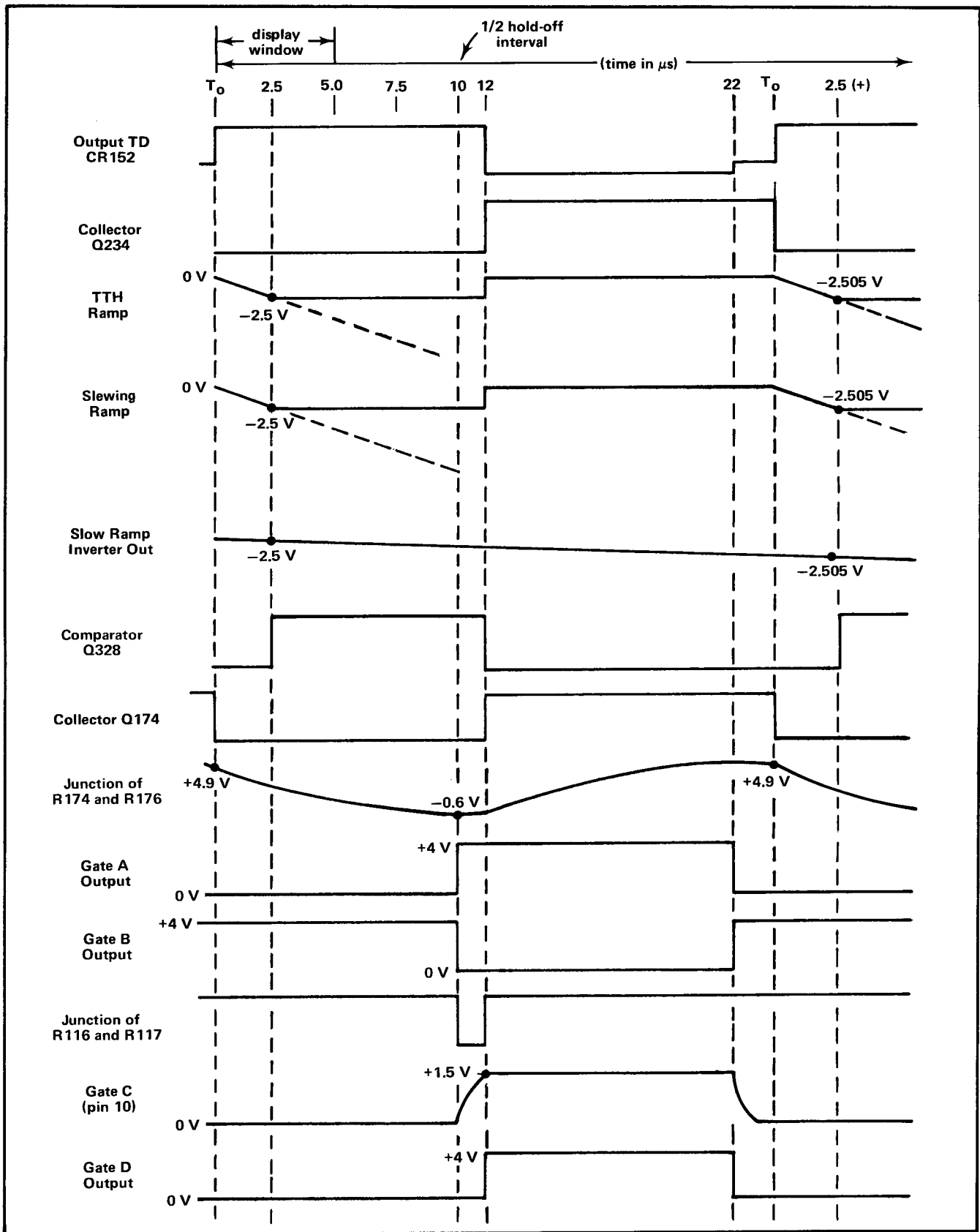

Fig. 3-31. Typical waveform relationships during sequential equivalent time sampling.

Current through Q308 is set to 5 mA, or to a value producing a Slewing Ramp having the same slope as the TTH ramp. Calibration adjustment R310 permits adjusting this current.

The 5 mA current is passing through Q306 just prior to trigger recognition. Immediately following trigger recognition, a negative-going pulse from Q234 drives Q304 into saturation. With Q304 saturated, Q306 is shut off and the 5 mA current is switched into the timing capacitor.

The parallel combination of C312 and C313 is used on the fastest sweep range. Capacitor C313 is a calibration adjustment for setting the Slewing Ramp slope equal to that of the TTH on the fastest sweep range. Additional capacitance (C318) is switched in on each of the three remaining equivalent time sweep ranges. The same amount of capacitance is added to the Slewing Ramp circuit as is added to the TTH circuit.

As the constant 5 mA current charges the timing capacitor, the voltage at the base of Q318 runs down from 0 volts toward -15 volts.

Slewing Ramp Comparator and Strobe Drivers

A voltage reference is provided by the Slow Ramp Inverter to the base of Q316. When the Slewing Ramp runs down to the level necessary to turn on Q316 and Q318, the ramp current is switched from the timing capacitor into a path through Q316 and Q318 thereby ends the rundown of the Slewing Ramp. The time duration of the Slewing Ramp rundown is dependent upon the voltage applied from the Slow Ramp Inverter to the base of Q316. When Q316 and Q318 turn on, Q322 turns on, causing tunnel diode CR328 to switch to its high state. Switching of CR328 is prevented during real-time operation by conduction of Q326. During equivalent-time operation sufficient reverse bias is applied to the base of Q326 to insure that it remains shut off.

When tunnel diode CR328 switches to its high level, germanium avalanche transistor Q328 fires, producing a fast drive pulse to transistors Q342 and Q344, thence to the right and left-hand sampling units. The positive-going pulse appearing at the collector of Q328 when Q328 fires is also fed through CR251 to Q252 in the TTH circuit. This turns on Q252 and Q252 saturates, shutting off the (-) Slope Drive to the TTH and ending the rundown of the TTH ramp.

As was pointed out during the discussion of Random mode operation in the Theory of Operation, during Random operation the TTH and Slewing Ramps do not normally start running together although a start pulse is de-

livered to the TTH (gate of Q294) by the Start Multivibrator at the same time as the Slewing Ramp is started. Also the TTH does not always run negative as it does during real-time and sequential operation. Other than the two exceptions just pointed out, the summary below applies to all modes of sampling.

To summarize, both the TTH and Slewing Ramps are started at the same time by Q234 (Start Multivibrator) immediately after Output TD (CR152) switches to its high state at time T_0 . As shown in Fig. 3-9 the TTH and Slewing Ramps both run negative at the same rate until voltage on the Slewing Ramp timing capacitor is negative enough to overcome the reverse bias between the base and emitter of Q316. When Q316 and Q318 conduct, the Slewing Ramp ends and CR328 switches state firing Q328. Firing of Q328 ends the rundown of the TTH ramp and causes Strobe Drivers Q342 and Q344 to deliver strobe pulses, thereby causing sampling of the vertical input signals. Firing of Q328 also provides a positive pulse to the base of Q368, which provides interdot blanking.

Slow Ramp Generator

REP SCAN operation. Refer to Fig. 3-32 and to the Slow Ramp Generator schematic at the rear of this manual. The slow ramp is generated by the Miller integrator consisting of transistors Q636 and the dual FET Q616. During REP SCAN operation, the input signal is applied to the left section of Q616 while the right section is grounded through R619. Transistor Q618 is the current source for Q616. The positive-going 10 volt Slow Ramp output is taken from the collector of Q636. Transistor Q634 terminates the output ramp when the collector of Q636 reaches approximately +10.2 volts.

Since the ramp can only run from 0 volts to approximately +10 volts before being reset, the slope and time duration of the output ramp is dependent upon R615 and C620, and the voltage at the collector of Q612. The voltage at the collector of Q612 can be set at any value of voltage between approximately -15 volts and 0 volts, using the SCAN control. The SCAN control provides a means of changing the slope and therefore the time duration of the ramp. With Q612 shut off, R612 and R613 set the emitter of Q612 at approximately +10 volts.

With the SCAN control fully clockwise, the wiper of R610 is connected to the +10 volt end of the control and Q612 current is shut off. This produces approximately -15 volts at the collector of Q612 and provides maximum input current through R615 to the Miller circuit. Turning the SCAN control counterclockwise permits increasing values of current through Q612 (up to a maximum of about 0.1 mA with the wiper of R610 at the ground end of the control).

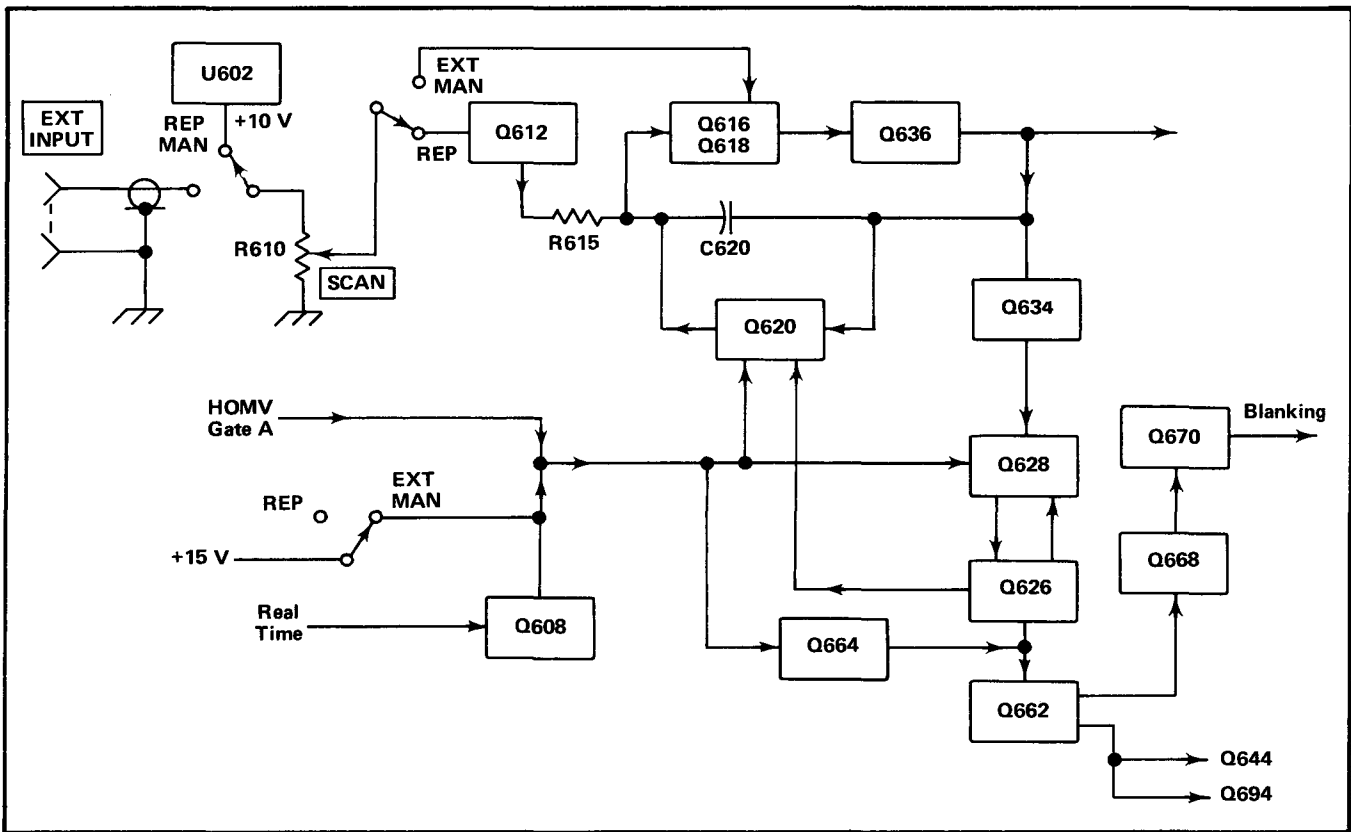

Fig. 3-32. Slow Ramp Generator block diagram.

Turning the SCAN control CCW reduces the input current to the Miller circuit and therefore reduces the slope of its output ramp. A longer time is therefore required for the ramp to run from 0 V to +10 volts. Since the ramp is running at a slower rate, more samples will be taken during a sweep, but fewer sweeps per second will be displayed.

Conditions just prior to run-up are: Gating transistor Q620 is on, thereby preventing run-up of the ramp; transistor Q662 is off, which provides slow sweep retrace blanking to the CRT; and Reset Multivibrator transistors Q628 and Q626 are both off. The TTH and Slewing Ramps, as well as the trigger and HOMV circuits are going through their normal cycles of operation.

The output pulse from gate A of the HOMV is applied to the base of Q628 through C630. Gate A output of the HOMV drops from approximately +4 volts to 0 volts as the HOMV resets to a ready for trigger condition. Provided sufficient time has elapsed since termination of the previous slow ramp, the negative pulse from the HOMV turns on Q628, which turns on Q626. Conduction of Q626 latches Q628 ON so that neither positive nor negative-going pulses from the HOMV will change the state of Q628 during the remainder of the slow ramp run-up. Conduction of Q626 also shuts off Gating transistor Q620, permitting the start

of the slow ramp run-up, and turns on transistor Q662 thereby removing slow ramp retrace blanking of the CRT.

The Slow Ramp Generator output voltage (collector of Q636) slowly rises from 0 volts to +10 volts at a rate determined by the setting of the SCAN control. During this slow rise, triggering signals are being recognized and the TTH and Slewing Ramps are periodically started and stopped.

The Slow Ramp output voltage charges C631 through CR631 and is also applied to the emitter of Q634. When the emitter of Q634 reaches approximately +10 volts, Q634 is turned on. Current through Q634, R634, and CR627 shuts off Q628, which shuts off Q626. When Q626 shuts off, Q620 turns on discharging C620 and resets the slow ramp output voltage to zero. When Q626 shuts off, transistor Q662 is shut off resulting in slow sweep blanking of the CRT.

When Q662 shuts off, Gate Control transistors Q644 and Q694 are both turned on. The conduction of Q644 prevents Dot Position Gating transistor Q650 from being turned on by an output from Q184 during Slow Ramp retrace time. The conduction of Q694 prevents turn on of

Ratemeter Correction Memory Gating transistors Q446 and Q448 by the output of Q546 during Slow Ramp retrace time.

Transistor Q628 is switched off by the conduction of reset Q634. Although transistor Q634 shuts off almost immediately due to loss of forward bias resulting from the turn on of Q620, transistors Q628 and Q626 remain shut off. Capacitor C631 is charged to approximately 10 volts and its discharge through R631 and CR627 holds off the Reset Multivibrator (Q628 and Q626) until the Slow Ramp Generator circuit has had time to reset and stabilize. When the current delivered through C630 (by a negative-going pulse from Gate A of the HOMV) exceeds the current discharging C631, diode CR627 will shut off and Q628 will be turned on. Q628 then turns on Q626 as the cycle repeats itself.

Slow-Sweep retrace blanking occurs when Q662 is shut off. With Q662 shut off Q668 conducts. Conduction of Q668 turns on Q670, which produces blanking. Overrun blanking also makes use of Q668. If the output of U672A or U672B exceeds +5 volts, Q668 will be turned on causing Q670 to turn on.

Slow Ramp retrace blanking is disabled or inhibited by turning on Q662. As previously mentioned, Q662 is turned on by the negative voltage at the collector of Q626 during run-up of the Slow Ramp. Slow Ramp retrace blanking is therefore prevented during this time. Q662 can also be turned on, disabling retrace blanking by turning on Q664. Transistor Q664 is turned on when the MAN or EXT INPUT SCAN pushbutton is pushed in. A voltage of +15 volts is delivered by switch S610 to R665 turning on Q664. Transistor Q664 can also be turned on, disabling retrace blanking, by selecting one of the three real-time Sweep Ranges. This is accomplished by Q608. Since the Slow Ramp Generator is not disabled during real-time operation, Slow Ramp blanking would occur during real-time operation on REP SCAN except for the disabling action of Q608. Conduction of Q608 also keeps gating transistor Q620 turned on, preventing slow ramp run-up, and holds Q628 and Q626 of the Reset Multivibrator off.

MAN and EXT INPUT SCAN. When the MAN or EXT INPUT is selected, the REP pushbutton is released to the out position. When in the out position, a contact of the REP pushbutton is connected to the +15 volt supply. This voltage prevents Slow Ramp blanking by turning on Q664 which turns on Q662. Q662 is normally on only when Reset Multivibrator Q626 and Q628 are on during generation of a slow ramp. The +15 volts mentioned above also keeps the Reset Multivibrator turned off and turns on Q620. With Q620 turned on, the collector of Q636 is connected to the gate of the left section of Q616.

When the MAN SCAN pushbutton is pushed in, Q616 and Q636 of the Slow Ramp Generator function essentially

as a high impedance voltage follower. The output voltage of U602 still appears across the SCAN potentiometer R610. Voltage picked off by the moveable contact of the SCAN control is applied to the right section of Q616. The output of Q616 is applied to the base of Q636 and appears at the collector of Q636. This output voltage is fed back to the left one-half of Q616 through the ON resistance of Q620. The X1 gain of the combination of Q616 and Q636 permits use of the SCAN control to set the 7T11 front panel SWEEP CAL adjustment. Since U602 provides an accurate +10 volt source, turning the SCAN through its range will result in 10 divisions of horizontal movement if the SWEEP CAL is properly set.

Operation is the same when EXT SCAN is selected except the SCAN control is now connected to the EXT SCAN INPUT jack.

Slow Ramp Inverter and Time Position Amplifier

Two sections of a quad operational amplifier are used for these two amplifiers. The other two sections of this four-section package are used as the Horizontal Output Amplifier. Inputs are delivered to the Slow Ramp Inverter (U572C) from four sources. See Fig. 3-33. The four sources are; Time Position Amplifier U572D, Servo Zero adjustment R588, the output of the Slow Ramp Generator Q636, and the output of the Dot Position Memory Q658. The Slow Ramp Inverter delivers an output to two circuits; Ratemeter Correction Memory Q434 and Slewing Ramp Comparator Q316.

The Time Position control provides a range of voltage from +10 volts (fully CCW) to 0 volts (fully CW) at the input of operational amplifier U572D. The output of the Time Position Amplifier simultaneously drives the input of the Horizontal Amplifier (U512A) and the Slow Ramp Inverter.

Time Position offset current sent through R573 effectively delays the TTH output in driving the input of the Horizontal Amplifier below the 0 volt level it requires to produce an output. Time Position current sent through R577 to the Slow Ramp Inverter delays firing of the Slewing Comparator. With firing of the Comparator delayed, the stopping of the TTH ramp and generation of the strobe pulses that cause sampling of the vertical signal are delayed. The time or display window is therefore delayed with respect to trigger recognition.

With the Time Position control R570A set fully CCW, the Time Position Amplifier (U572D) supplies a 1 mA offset current to the input of the Slow Ramp Inverter. The output of Q592 collector is shifted negative, by 5 volts, from the value determined by the other three outputs.

The output of the Slow Ramp Inverter is fed to the base of Q434 and Q316. With the reference at the Slewing Ramp

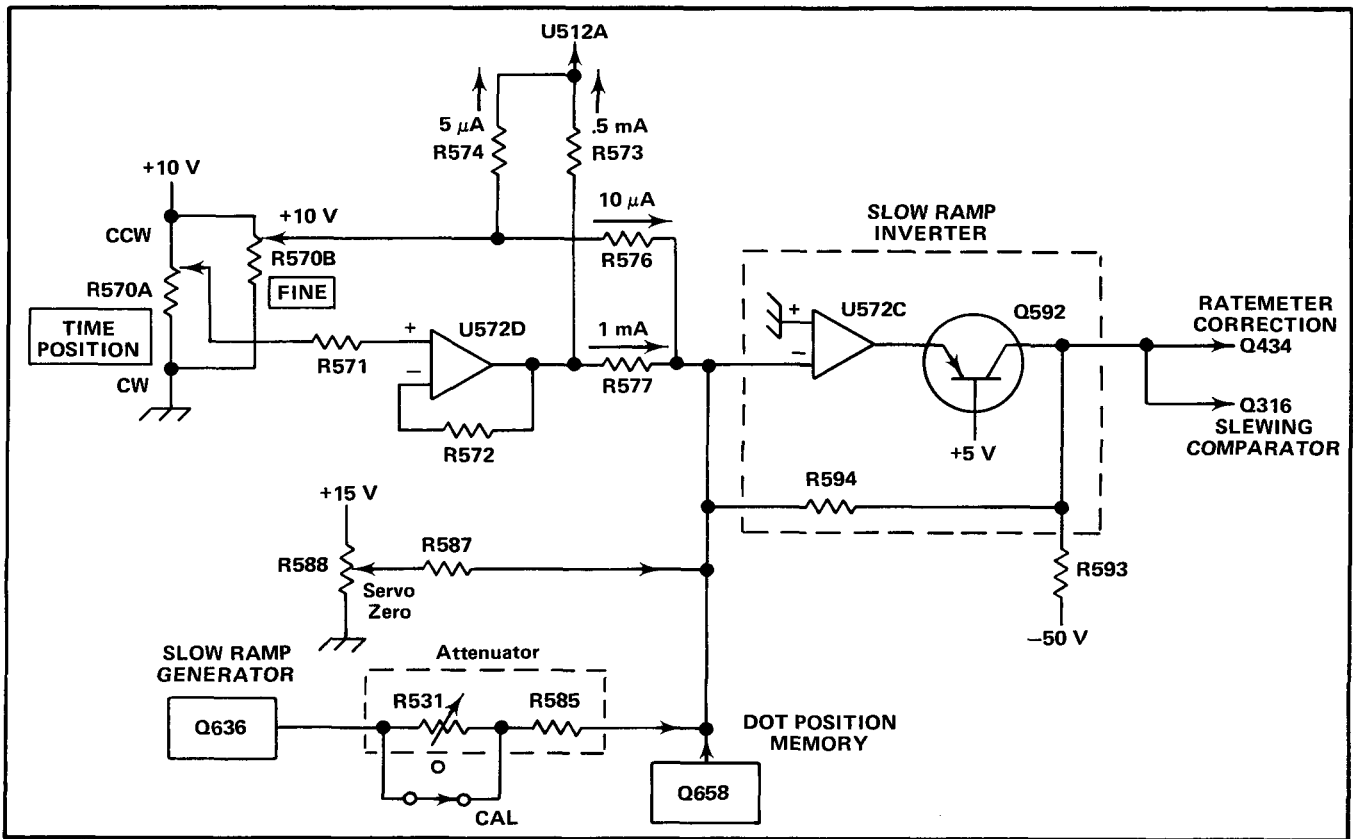

Fig. 3-33. Inputs and outputs of the Slow Ramp Inverter.

Comparator (base of Q316) 5 volts more negative, the Slewing Ramp must run 5 volts more negative to produce a strobe. The first sample and the start of the display window now occur one Time Position Range after T_0 .

The Slow Ramp Inverter output delivered to the base of Q434 is explained later in this section under the heading of Ratemeter.

Another input to the Slow Ramp Inverter is delivered through an attenuator from transistor Q636 of the Slow Ramp Generator. The Slow Ramp Generator output is attenuated by the same factor that the Horizontal Amplifier gain is increased, and is determined by the setting of the TIME/DIV control. Attenuating the Slow Ramp maintains dot density constant as the TIME/DIV control is rotated.

The 20 kΩ Variable control is ganged to the Variable control shown at the input to the Horizontal Amplifier and both Variable controls are shorted out in the CAL position. The attenuators at the Slow Ramp Inverter input are shown on the schematic at the rear of this manual set to the position producing zero attenuation. This same condition

(TIME/DIV at X1 Mag setting) is represented in Fig. 3-33 where only R585 is connected to the Slow Ramp Inverter input. The 0.5 gain (set by ratio of R594 to R585) of the Slow Ramp Inverter results in a positive 5-volt change at the Slow Ramp Generator output appearing as a -2.5 volt change at the Slow Ramp Inverter output.

In addition to the output of Time Position Amplifier U572D and the output of the Slow Ramp Generator, two more inputs are applied to the input of the Slow Ramp Inverter. These two inputs are discussed immediately below under the heading of Dot Position Memory.

Dot Position Memory

Inputs to the Slow Ramp Inverter are supplied by Servo Zero adjustment R588 through R587 and by the Dot Position Memory through R586. The purpose of the Servo Zero adjustment is to set the output of the Dot Position Memory as near zero as possible.

As explained in the Theory of Operation portion of this section, a very small voltage at the input of the Horizontal Amplifier can result in a considerable error in the horizontal placement of samples on the CRT. The Dot Position

Memory detects errors in the Horizontal Amplifier output by using the Slow Ramp Generator output as a reference. Refer to the Slow Ramp Generator schematic at the rear of this manual.

The 0 volt to +10 volt output of the Slow Ramp Generator is applied across R644, R646, and R645. The +5 volt to -5 volt output of Output Amplifier U672B is applied across R647, R646 and R645. Resistors R646 and R645 provide an offset to make up for the zero level shift of the memory. With no Output Amplifier error, the positive-going voltage from the Slow Ramp Generator, plus the negative-going voltage from U672B, plus the offset provided by current through R646 and R645 results in 0 volts at the input of the memory (collector of Q652).

Assume a condition that should place a dot horizontally at the center of the CRT. The Slow Ramp Generator output is at +5 volts and when the Slewing Ramp reaches -5 volts the Comparator Q316 will fire, stopping the TTH ramp. The TTH voltage should be -2.5 volts and will appear at the output of the Horizontal Memory as 0 volts. This will place a dot at the horizontal center of the CRT. If a slight voltage error at the Horizontal Amplifier input causes the Output Amplifier voltage to lag, an error voltage will appear at the input of the Dot Position Memory. If the voltage at the output of U672B is +1 volt, instead of the 0 volts that should be present with a slow ramp output voltage of +5 volts, a dot will be placed to the left of graticule center. The result of error in the relationship of these two voltages is a positive error voltage at the collector of Q652.

When the Trigger Output TD switches to its low level at 1/2 hold-off interval, a negative-going pulse is applied from the collector of Q184 to the base of Q650. Transistor Q650 turns Q652 and Q654 on, resulting in the error voltage being stored on C654. Resistors R648 and R649 reduce the circuit sensitivity as the gain of the Horizontal Amplifier is increased to prevent overcorrection of dot position error and resultant Dot Position Servo oscillation.

A positive error voltage stored on C654 results in a positive voltage at the output of the Dot Position Memory. The effect of this voltage is to shift negative the reference voltage applied by the Slow Ramp Inverter to the Comparator. The TTH runs longer as a result of the positive error at the input of the Dot Position Memory and the next sample will be positioned closer to its proper position.

If the sample is being displayed to the right of its proper position, a negative error signal appears at the Dot Position Memory input and the TTH will be stopped earlier than normal.

Transistor Q644 is provided to disable gating transistor Q650 during Slow Ramp retrace.

Ratemeter

The purpose of the Ratemeter (see Fig. 3-34) is to start the displayed portion of the sweep before a trigger arrives, thus permitting time before triggering to be displayed. The Ratemeter estimates when the next trigger will occur by measuring time from Ratemeter reset (1/2 hold-off interval) to the next trigger recognition, or T_0 .

Pretrigger Comparator. The Pretrigger Comparator (Q414 and Q416) is responsible for delivering an output, from the collector of Q416 to the base of Q230, to get the trace started prior to arrival of the triggering signal. The Pretrigger Comparator will deliver an output pulse when Q416 conducts. Conduction of Q416 occurs when Q414 is shut off. Transistor Q414 shuts off when its base voltage reaches a more negative voltage than is present at the base of Q416.

The voltage at the base of Q414 is determined by the voltage to which capacitor C414 in the Triple Log Ratemeter Ramp has charged. The voltage at the base of Q416 can be considered to be the result of the output of two sources. These two sources are the output of Q422, supplied through R424, and the output of the Start Correction circuit taken from the collectors of Q462 and Q464. The Start Correction Input will be discussed after the Ratemeter outputs supplied to the base of Q414 and Q416 are explained.

Triple Log Ratemeter Ramp. The Triple Log Ratemeter Ramp consists of R408 and R409 serving as the source of charging voltage for the ramp, resistors R411 and R412, capacitors C411, C412, and C414, and two diodes. Resistors R408 and R409 together with the -50 volt supply can be considered to be a source of approximately -15 volts and having a resistance of about 12 k Ω . This 12 k Ω resistor in parallel with R411 and R412 forms a divider network that charges C414 to a negative voltage of about -5 volts, or 1/3 of 15 volts. The time constant is 80 μ s (see Fig. 3-35), set by C414 and the parallel combination of the four resistors. Charging starts immediately after the network is discharged by the Reset Multivibrator.

After the network reaches the -5 volt level, C412 charges toward -10 volts from 0 volts with a time constant of C412 (R412 + parallel resistance of R411, R408, and R409) or approximately 800 μ s. As C412 charges, the junction of the 4 resistors slides from -5 volts to -10 volts. Then C411 begins to charge from 0 volt to -15 volts with a time constant of C411 (R411 + parallel resistance of R408 and R409) or about 8 ms. The junction of the four resistors slides from -10 volts to -15 volts during this time.

The Triple Log Ratemeter Ramp eliminates the need to switch Ratemeter capacitors when the Sweep Range setting

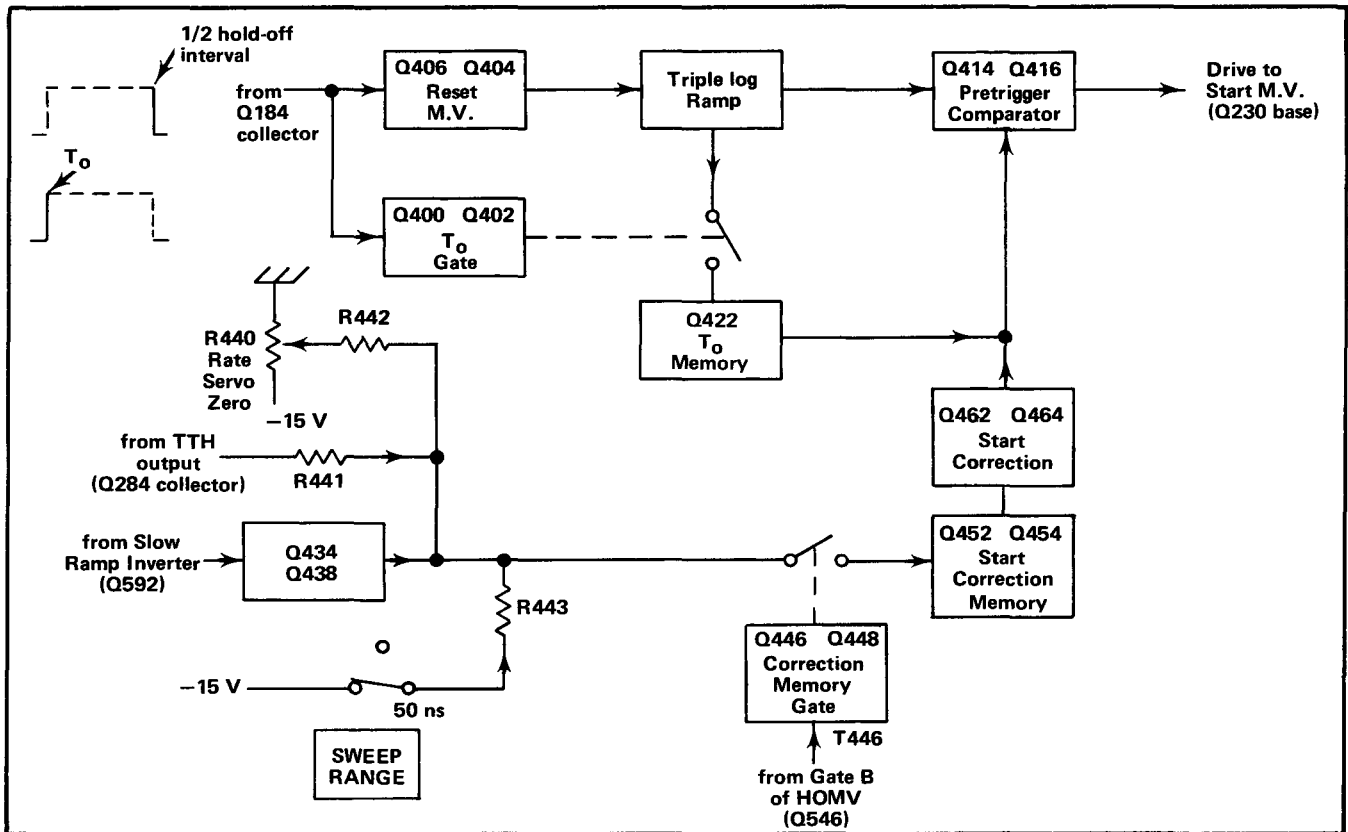

Fig. 3-34. Simplified block diagram of Ratemeter circuit.

is changed and to specify lower limits for trigger repetition rate for each Sweep Range.

Reset Multivibrator. The Reset Multivibrator (Q404 and Q406 of Fig. 3-34) is used to discharge the capacitors in the

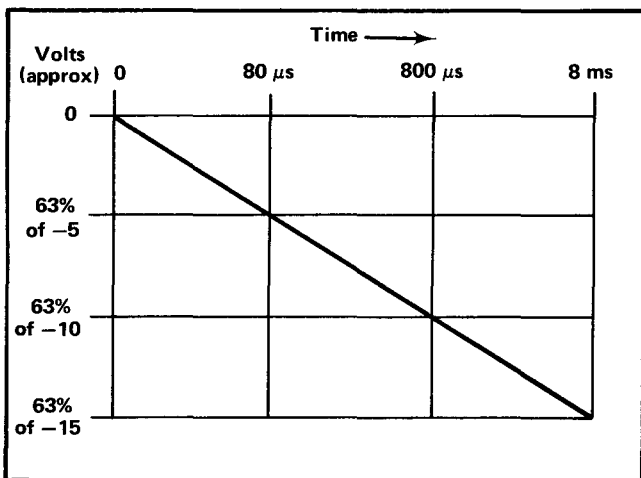

Fig. 3-35. Theoretical change in voltage of Ratemeter Triple Log Ramp capacitor (C414) with charging time.

Ratemeter Ramp network. The Reset Multivibrator is turned on at 1/2 hold-off interval by the negative-going portion of the pulse supplied by Q184. This pulse coincides in time with the time during which the Trigger Output TD (CR152) is reset to the low state. The negative-going portion of this pulse is fed through C402 to the base of the Reset Multivibrator. Turning on the Reset Multivibrator discharges the negative charge on C411, C412, and C414.

Discharge of C411 and C412 occurs through the low resistance path offered by CR411 and CR412 respectively. After reset, conduction of the diodes stops.

T₀ Memory and T₀ Gate. The purpose of the T₀ Memory is to supply an input to the Pretrigger Comparator that is an indication of what length of time interval existed between the 1/2 hold-off interval and trigger recognition (T₀), during the previous run of the Ratemeter Ramp.

The input supplied to the base of Q416 by the T₀ Memory transistor Q422, is dependent upon the charge on C421. The charge on T₀ Memory capacitor C421 is determined by the voltage of the Ratemeter Ramp at the time the T₀ Gate is turned on. The T₀ Gate is turned on by the positive-going portion of the pulse appearing at the collec-

tor of Q184. The positive-going portion of this pulse results from the Trigger Output TD switching to its high level when it recognizes a trigger. This pulse is coupled through C401 to transformer T400 and appears as a negative pulse at the emitters of T_O Gate transistors Q400 and Q402. Diode CR400 limits base-emitter reverse bias to a few tenths of a volt.

When the T_O Gate transistors are turned on, the T_O Memory capacitor C421 is connected to the Ratemeter Ramp network through the low resistance of the Gate transistors. With the Gate turned on, C421 adjusts its voltage to that of the Ratemeter Ramp. If a constant trigger repetition rate is assumed, the Ratemeter always reaches the same level between reset and T_O .

With a constant trigger repetition rate and ignoring the signal delivered by the Start Correction circuit (Q462 and Q464), the Pretrigger Comparator will deliver an output at time T_O . The Ratemeter seems to be serving no purpose since we want it to start the trace before time T_O . Actually, the circuits discussed provide an input to the base of Q416 that is dependent upon trigger repetition rate. The time between outputs from the Pretrigger Comparator will quickly adjust to the new T_O time interval. The leadtime required to get the trace started prior to trigger recognition is provided by the signal delivered by the Start Correction circuit (Q462 and Q464).

If the triggering interval is very random, it is possible for trigger recognition to occur part of the time prior to Pretrigger Comparator output in spite of the leadtime provided. This presents no problems however, but results in the Start Multivibrator being turned on by the trigger instead of the Pretrigger Comparator. The vertical input will be sampled and the sample displayed following T_O by a time interval dependent upon the value of the Slow Ramp Inverter output.

Ratemeter Start Correction Circuits

Leadtime and start correction inputs are delivered to the Pretrigger Comparator (base of Q416) from the collectors of Q462 and Q464. Fig. 3-34 shows that the sum of four inputs can be connected to the Start Correction Memory (Q452 and Q454) by turning on the Correction Memory Gate.

The four inputs are from the Rate Servo Zero adjustment, TTH output, Slow Ramp Inverter, and the -15 volts supplied through R443 at the fastest setting (fully CCW) of the SWEEP RANGE switch. The TIME POS RNG is 50 ns at this setting.

The Rate Servo Zero adjustment (R440) provides the 1/2 TPR (time positioning range) of leadtime introduced

during the Random Mode of operation. An additional 50 ns of leadtime is introduced at the fastest Sweep Range setting by the input through R443.

The TTH and Slow Ramp Inverter inputs provide correction if the TTH and Inverter output voltages do not differ by the correct amount for the intended leadtime. If the output of the Pretrigger Comparator is too early, possibly due to an increase in time between triggers, the TTH output will be more positive with respect to the Slow Ramp Inverter output than it should be. When Gate transistors Q446 and Q448 are turned on, a less negative than normal voltage will be stored on C451. This results in a more negative voltage at the base of Pretrigger Comparator transistor Q416 and delays firing of the Pretrigger Comparator.

Transistor Q434 provides inversion of the negative-going output of the Slow Ramp Inverter. Gating transistors Q446 and Q448 are turned on by a pulse induced in the secondary of T446 when a pulse is applied to the primary of T446. Diode CR446 prevents the negative-going portion of the applied pulse from inducing an excessive reverse-bias voltage across the base-emitter junction of Q446 or Q448.

The pulse that turns on Gate Transistors Q446 and Q448 is the same as that used for Horizontal Memory drive. At 1/2 Holdoff time Q546 turns on and a positive-going pulse is coupled through CR547 to the bottom of transformer T446 primary. This positive-going pulse turns on Q446 and Q448 except when Q694 is turned on. Q694 is turned on during Slow Ramp Generator retrace time and during Sequential or Real-time operation. With Q694 conducting, the top of T446 primary is grounded. This reverse biases diode CR547 and prevents coupling of the positive pulse to T446.

Timing Switches

General. The Timing Switches diagram at the rear of this manual shows the SWEEP RANGE switch S530B and the TIME/DIV switch S530A. Twenty cams are provided on each of these switches. Switch S530B does not utilize cams 7, 11, or 12. On both of these switches the cam numbers are determined by considering the cam nearest the instrument front panel to be number 1. The switch actuated by each cam is shown by a dotted line connecting the cam number and the switch.

With the SWEEP RANGE switch turned fully clockwise to its slowest speed setting (5 ms/div to 10 μ s/div) a reading of 50 ms is indicated in the TIME POS RNG window. Dots are used to indicate which cams close switches at this setting of the Sweep Range switch. Proceeding horizontally from 50 ms shows that cams 17, 15, 9 and 3 are closing their switches.

The TIMING SWITCHES diagram also shows which cams operate switches at each of the nine positions of the TIME/DIV switch. With the Time/Div set fully CCW to the slowest available speed (5 ms/div with the TIME POS RNG window indicating 50 ms) the magnification is X1. At this setting of the TIME/DIV switch, cams 1, 4, 9, 12, 15, 17 and 19 close the switches to which they are connected as shown by dotted lines.

Switches operated by cams of the SWEEP RANGE and TIME/DIV controls are used to produce circuit changes required by different sweep rates and modes of operation. Among changes provided by these switches are changes in hold-off, gain, attenuation, logic, and ramp slope.

Readout. Readout logic is provided to the oscilloscope readout circuitry by some of the cams of the Sweep Range and Time/Div switches. On the Sweep Range switch (S530B) cams 1, 2, 3 and 4 are used. On the Time/Div switch (S530A) cams 17, 18, 19 and 20 are used. Another switch (S531C), activated when the front panel VARIABLE (CAL IN) knob is in the out position, also provides readout logic. With S531C closed, a Column current of 0.2 mA and a Row current of 0.1 mA will be provided to the oscilloscope readout circuitry during time slot 3. The symbol for less than (<) will appear on the CRT, just to the left of the time per division readout.

With the SWEEP RANGE switch at its fully clockwise position and the TIME/DIV switch set fully counterclockwise, the CRT readout is 5 ms. The TIMING SWITCHES diagram shows that the switch controlled by cam 3 of the Sweep Range switch is closed, thereby providing a current path through R745. Switches controlled by cams 17 and 19 of the Time/Div switch are also closed, providing current paths through R752 and R755. The effect of closing contact 3 of the Sweep Range switch and contacts 17 and 19 of the TIME/DIV switch can be determined by consulting Table 3-2.

Reference to Table 3-2 indicates that during time slot 1 closing of contacts 3 and 19 causes the instruction "reduce prefix" to be stored by the oscilloscope readout circuit. Table 3-2 also indicates that during time slot 4 the number 5 is selected and displayed by the oscilloscope readout.

During time slot 8 Table 3-2 shows that the prefix micro (μ) is selected since neither contact 1 nor 2 is closed. The selected prefix (μ) is not displayed by the readout however, since during time slot 1 the instruction to reduce the prefix was stored. Therefore, the milli (m) symbol is selected and displayed by the oscilloscope readout circuits.

TABLE 3-2
7T11 Readout Switching

Time Slot 1 (B33)

3	4	19	20	Column Current	Row Current	Information Stored
R745 150k	R744 75k	R752 75k	R751 150k	A37	B37	
					0.2 mA	None
			X	0.1 mA	0.2 mA	Add 1 zero
		X		0.2 mA	0.2 mA	Add 2 zeros
	X			0.2 mA	0.2 mA	Add 2 zeros
X				0.1 mA	0.2 mA	Add 1 zero
	X		X	0.3 mA	0.2 mA	Reduce prefix
X			X	0.2 mA	0.2 mA	Add 2 zeros
	X	X		0.4 mA	0.2 mA	Reduce prefix & add 1 zero
X		X		0.3 mA	0.2 mA	Reduce prefix

Time Slot 4 (A32)

17	18	Column Current	Row Current	Character Selected
R755 37.5k	R754 150k	A37	B37	
		0.2 mA	0.0 mA	1
	X	0.3 mA	0.0 mA	2
X		0.6 mA	0.0 mA	5

Time Slot 8 (A30)

1	2	Column Current	Row Current	Symbol Selected
R743 150k	R747 75k	A37	B37	
		0.2 mA	0.3 mA	μ
X		0.3 mA	0.3 mA	n
	X	0.4 mA	0.3 mA	p

The remaining symbol required to produce a readout of 5 ms is selected during time slot 9. During time slot 9 a Column current of 0.1 mA passes through R741 and a Row current of 0.4 mA passes through R765. These values of current cause the symbol for second (s) to be selected.

For more specific information on the readout circuitry, refer to the Circuit Description section of your Tektronix 7000-series oscilloscope.

SECTION 4 MAINTENANCE

Change information, if any, affecting this section will be found at the rear of the manual.

Introduction

This section of the manual contains information for use in preventive maintenance, corrective maintenance and troubleshooting of the 7T11.

PREVENTIVE MAINTENANCE

General

Preventive maintenance consists of cleaning, visual inspection, lubrication, etc. Preventive maintenance performed on a regular basis will improve the reliability of this instrument. The severity of the environment to which the 7T11 is subjected determines the frequency of maintenance. A convenient time to perform preventive maintenance is preceding recalibration of the instrument.

Cleaning

The side panels of the 7T11 provide protection against dust in the interior of the instrument. Operation without the panels in place necessitates more frequent cleaning.

CAUTION

Avoid the use of chemical cleaning agents which might damage the plastics used in this instrument. Avoid chemicals which contain benzene, toluene, xylene, acetone or similar solvents.

Exterior. Loose dust accumulated on the outside of the 7T11 can be removed with a soft cloth or small paint brush. The paint brush is particularly useful for dislodging dirt on and around the front-panel controls. Dirt which remains can be removed with a soft cloth dampened in a mild detergent and water solution. Abrasive cleaners should not be used.

Interior. Dust in the interior of the instrument should be removed occasionally due to its electrical conductivity under high-humidity conditions. The best way to clean the interior is to blow off the accumulated dust with dry, low-pressure air. Remove any dirt which remains with a soft paint brush or a cloth dampened with a mild detergent and water solution. A cotton-tipped applicator is useful for cleaning in narrow spaces on circuit boards.

Lubrication

The reliability of potentiometers, switches and other moving parts can be maintained if they are kept properly lubricated. However, too much lubrication is as detrimental as too little lubrication. A lubrication kit containing the necessary lubricants and instructions is available from Tektronix, Inc. Order Tektronix Part No. 003-0342-01.

Visual Inspection

The 7T11 should be inspected occasionally for such defects as broken connections, damaged or improperly installed circuit boards, and heat-damaged parts.

The corrective procedure for most visible defects is obvious; however, particular care must be taken if heat damaged components are found. Overheating usually indicates other trouble in the instrument; therefore, it is important that the cause of overheating be corrected to prevent recurrence of the damage.

Semiconductor Checks

Periodic checks of the semiconductors in the 7T11 are not recommended. The best check of semiconductor performance is actual operation in the instrument. More details on checking semiconductor operation are given under troubleshooting.

Recalibration

To ensure accurate measurements, check the calibration of the 7T11 after each 500 hours of operation or every six months if used infrequently. In addition, replacement of components may necessitate recalibration of the affected circuits. The calibration procedure can also be helpful in localizing certain troubles in the instrument. In some cases, minor troubles may be revealed and/or corrected by recalibration.

TROUBLESHOOTING

Introduction

The following information is provided to facilitate troubleshooting of the 7T11. Information contained in other sections of this manual should be used along with the

following information to aid in locating the defective component. An understanding of the circuit operation is very helpful in locating troubles. See the Circuit Description section for complete information.

Troubleshooting Aids

Wiring Color-Code. All insulated wire and cable used in the 7T11 is color-coded to facilitate circuit tracing. Table 4-1 gives the wiring color-code used in the 7T11.

TABLE 4-1

Power Supplies Wire Color Code

Supply	Color Code
+50 V	Orn/Red
+15 V	Brn/Red
+5 V	Blk/Red
-15 V	Blk/Vio
-50 V	Brn/Vio

Resistor Color-Code. In addition to the brown composition resistors, some metal-film resistors are used in the 7T11. The resistance values of composition resistors and metal-film resistors are color-coded on the components with EIA color-code (some metal-film resistors may have

the value printed on the body). The color-code is read starting with the stripe nearest the end of the resistor. Composition resistors have four stripes that consist of two significant figures, a multiplier and a tolerance value (see Fig. 4-1). Metal-film resistors have five stripes consisting of three significant figures, a multiplier and a tolerance value.

Capacitor Marking. The capacitance values of common disc capacitors and small electrolytics are marked in microfarads on the side of the component body. The white ceramic capacitors used in the 7T11 are color-coded in picofarads using a modified EIA code (see Fig. 4-1).

Diode Color-Code. The cathode end of each glass-encased diode is indicated by a stripe, a series of stripes or a dot. For most silicon or germanium diodes with a series of stripes, the color-code identifies the three significant digits of the Tektronix Part Number using the resistor color-code system (e.g., a diode color-coded pink-, or blue-, brown-gray-green indicates Tektronix Part Number 152-0185-00).

Semiconductor Lead Configuration. Fig. 4-2 shows the lead configuration for the semiconductors used in this instrument. This view is as seen from the bottom of the semiconductors.

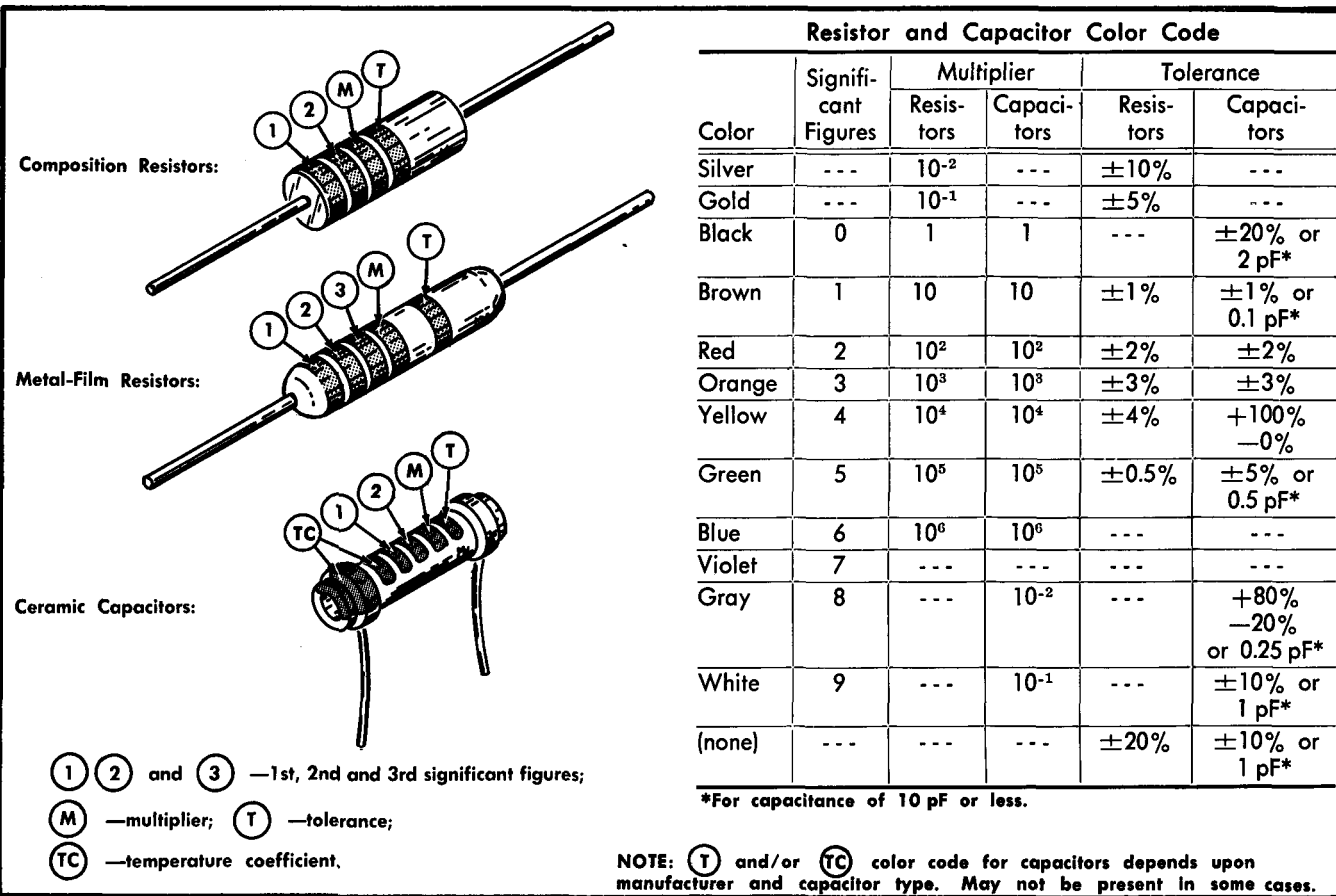

Fig. 4-1. Resistor and ceramic capacitor color-code.

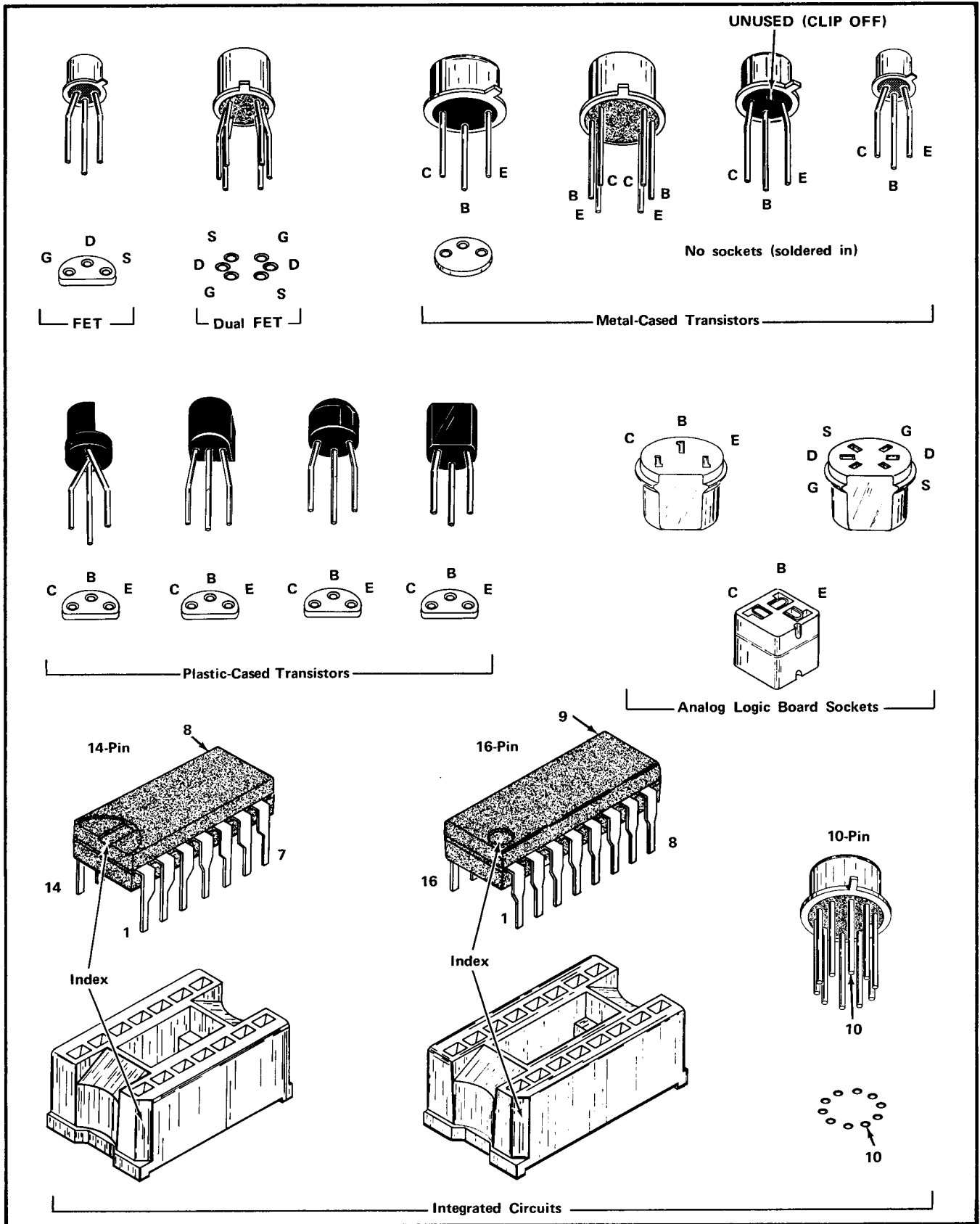

Fig. 4-2. Transistor and integrated circuit pin and socket arrangement.

Troubleshooting Techniques

The first few troubleshooting checks ensure proper connection, operation and calibration. If the trouble is not located by these checks, the remaining steps aid in locating the defective component. When the defective component is located, it should be replaced following the replacement procedures given under Corrective Maintenance.

1. Check Control Settings. Incorrect control settings can indicate a trouble that does not exist. If there is any question about the correct function or operation of any control, see the Operating Instructions section.

2. Check Associated Equipment. Before proceeding with troubleshooting of the 7T11, check that the indicator oscilloscope and equipment used with this instrument is operating correctly. Check that the signal is properly connected and that the inter-connecting cables are not defective. Also, check the power source.

3. Visual Check. Visually check the portion of the instrument in which the trouble is located. Many troubles can be located by visual indications such as unsoldered connections, broken wires, damaged circuit boards, damaged components, etc.

4. Check Instrument Calibration. Check the calibration of the affected circuit if the trouble appears in one circuit. The apparent trouble may only be a result of misadjustment or may be corrected by calibration. Complete calibration instructions are given in the Calibration section.

5. Isolate Trouble to a Circuit. To isolate trouble to a particular circuit, note the trouble symptom. The symptom often identifies the circuit in which the trouble is located. When trouble symptoms appear in more than one circuit, check affected circuits by taking voltage and waveform readings. Also check for the correct output signals at the front-panel output connectors with a test oscilloscope. If the signal is correct, the circuit is working correctly up to that point.

6. Check Voltage and Waveforms. Often the defective component can be located by checking for the correct voltage or waveform in the circuit. Typical voltages and waveforms are given on the diagrams.

NOTE

Voltages and waveforms given on the diagrams are not absolute and may vary slightly between instruments. To obtain operating conditions similar to those used to take these readings, see the first diagram page.

7. Check Individual Components. The following procedures describe methods of checking individual components in the 7T11. Components which are soldered in place are best checked by first disconnecting one end. This isolates the measurement from the effects of surrounding circuitry.

A. SEMICONDUCTORS

CAUTION

Power switch must be turned off before removing or replacing semiconductors.

A good check of transistor operation is its actual performance under operating conditions. A transistor can most effectively be checked by substituting one that has been checked previously. However, be sure that circuit conditions are not such that a replacement transistor might also be damaged. If substitute transistors are not available, use a dynamic tester. Static-type testers are not recommended, since they do not check operation under simulated operating conditions.

Integrated circuits can be checked with a voltmeter, test oscilloscope, or by direct substitution. A good understanding of the circuit description is essential to troubleshooting circuits using integrated circuits. In addition, operating waveforms, logic levels and other operating information for the integrated circuits are given in the Circuit Description section. Use care when checking voltages and waveforms around the integrated circuits so that adjacent leads are not shorted together. Use proper tools while removing or inserting integrated circuits. A convenient means of clipping a test probe to the 14 and 16-pin integrated circuits is with an integrated circuit test clip. This device also doubles as an integrated circuit extraction tool.

A diode can be checked for an open or shorted condition by disconnecting one end of the diode and measuring the resistance between terminals. With an ohmmeter scale having an internal source of between 800 millivolts and 3 volts, the resistance should be very high in one direction and very low when the meter leads are reversed.

CAUTION

Do not use an ohmmeter scale that has a high internal current. High currents may damage the diode.

B. RESISTORS

Check the resistors with an ohmmeter. See the Electrical Parts List for the tolerance of the resistors used in this instrument. Resistors normally do not need to be replaced.

C. INDUCTORS

Check for open inductors by checking continuity with an ohmmeter. Shorted or partially shorted inductors can usually be found by checking the waveform response when high-frequency signals are passed through the circuit. Partial shorting often reduces high-frequency response (causes roll-off).

D. CAPACITORS

A leaky or shorted capacitor can best be detected by checking resistance with an ohmmeter on the highest scale. Do not exceed the voltage rating of the capacitor. The resistance reading should be high after initial charge of the capacitor. An open capacitor can best be detected with a capacitance meter or by checking if the capacitor passes AC signals.

8. Repair and Readjust the Circuit. If any defective parts are located, follow the replacement procedures given in this section. Be sure to check the performance of any circuit that has been repaired or that has had any electrical components replaced.

7T11 Troubleshooting Procedure

If the instrument is operating well except for certain settings of one or two controls, then troubleshooting can usually be limited to the areas affecting the operation of the unit for these settings. In event of extensive failure, the following procedure outlined below can sometimes help to speed up repairs.



Power switch must be turned off before removing or replacing the plug-in.

Remove the 7T11 from the indicator frame and check the power supply buses (including the 10-volt reference bus) for shorts to ground. Turn off the power to the indicator and connect the 7T11 to the oscilloscope via an extender plug-in (order Calibration Fixture, Tektronix Part No. 067-0589-00). Connect J334 (7T11) and J430 (7S11) using the RF Cable Assembly (Tektronix Part No. 012-0203-00).

Turn the power on.

Check—power supply voltages, including the 10-volt reference supply provided by U602.

Check—trigger selection circuit for proper operation.

Check—reed switch drive coils for applied voltage (+5 V) when the actuating button is pushed.

Check—to make sure the reed switch is actuated by the use of an ohmmeter.

Check—Trig source switch

INT –	voltage to the Int coil, +5 V
EXT, 50 Ω	voltage to the Ext, 50 Ω coil, +5 V
EXT, 1M	voltage to the 1 Meg coil, +5 V
HF SYNC	voltage to all coils, 0 V, slope and trig amp lights out
All buttons up	voltage to the Ext, 50 Ω coil, +5 V

Check—Trig Amp Switch

X1	no coil voltage, Q82 input connected to gnd.
X10	voltage to the X10 coil, +5 V, Q82 input connected to the trig line.

Check—Trig Slope Switch

+	voltage to the + coil, +5 V
–	voltage to the –coil, +5 V

Check—operation of 1 MEG Ω amplifier and set the DC Bal for zero input-output differential with zero signal input.

Check—operation of the X10 amplifier. Measure from the junction of CR95 and CR96 to ground. Output should be zero when X10 pushbutton is actuated (use 50 Ω , external source, zero signal). Output should drop to approximately –0.5 volts in the X1 position.

Check—Schmitt circuit for operation. Set the STABILITY pot CCW. Voltage at the varistor light bulb should be zero. Set the STABILITY pot CW. Voltage at the varistor light bulb should be about 4 volts. The Schmitt circuit should not free run at any setting of the TRIG LEVEL control with the STABILITY control CCW.

Maintenance—7T11

Check—Trig Level zero. Set the STABILITY control for free running within a narrow band. The Schmitt circuit should still free run within this narrow band when + or –slope is selected.

Check—TRIG LEVEL indicator dot should be at 2 o'clock when Trig Level Zero is properly adjusted. For this check use 50 Ω , ext trig input, zero signal.

Check—that the Arming Bias and Output Bias pots are set for triggered operation. Use 1 μ sec period, Type 284 drive source.

Check—the holdoff Multivibrator should now run. Check for operation in all equivalent time (sequential) position ranges.

Check—for operation of the following circuits with the Holdoff multivibrator running. Set the TIME POSITION RANGE to 5 μ s and refer to waveforms shown on the schematics at the rear of this manual.

- a. Pulse Out Driver—When this circuit is functioning, the test scope can be triggered by this pulse.
- b. Trig Coupling Amplifiers
- c. Start Multivibrator
- d. Slewing Ramp—It may be necessary to unplug one end of the 510 ohm resistor (R586). Set the Horiz Amp Mag at X1 and TIME POSITION control to midrange.
- e. Time Position Voltage AMP (U572D)
- f. Slow Ramp Generator
- g. Slew Ramp Comparator—the collector of Q328 should change from –15 V to about +3 volts in two nanoseconds.
- h. Strobe Drivers—To get an output, return the collector of Q342 to ground through a resistor (100 Ω to 1k).
- i. Stop Drive to (–) Slope Driver

j. Time to Height Converter

k. Horizontal Amplifier

l. Horizontal Memory Gate Driver

m. Horizontal Memory—the memory gate balance pot may now be set.

n. Output Amplifiers

o. Dot Position Memory—Once the output amplifiers have been checked, reconnect the 510 Ω resistor.

Check—Time To Height Converter output. Switch the Mode from Sequential to Random. Set TIME POSITION RANGE to 5 μ sec or 50 μ sec. Set the TIME POSITION pot CCW. Use the test oscilloscope and monitor the Time To Height output. The plateau between the start multivibrator firing and the trigger input should be flat, with no + or – slope.

If the unit does not work properly in random, check the ratemeter and the ratemeter correction memory for correct operation.

Check—for operation in real time. If not functional in the .5 μ sec TIME POSITION RANGE, check the Real Time Multivibrator and feedback reset path through Q554 to the Hold Off Multivibrator.

CORRECTIVE MAINTENANCE

General

Corrective maintenance consists of component replacement and instrument repair. Special techniques required to replace components in this instrument are given here.

Obtaining Replacement Parts

Standard Parts. All electrical and mechanical part replacement for the 7T11 can be obtained through your local Tektronix Field Office or representative. However, many of the standard electronic components can be obtained locally in less time than is required to order them from Tektronix, Inc. Before purchasing or ordering replacement parts, check the parts list for value, tolerance, rating and description.

NOTE

When selecting replacement parts, it is important to remember that the physical size and shape of a com-

ponent may affect its performance in the instrument, particularly at high frequencies. All replacement parts should be direct replacements unless it is known that a different component will not adversely affect instrument performance.

Special Parts. In addition to the standard electronic components, some special components are used in the 7T11. These components are manufactured or selected by Tektronix, Inc. to meet specific performance requirements, or are manufactured for Tektronix, Inc. in accordance with our specifications. These special components are indicated in the Electrical Parts List by an asterisk preceding the part number. Most of the mechanical parts used in this instrument have been manufactured by Tektronix, Inc. Order all special parts directly from your local Tektronix Field Office or representative.

Ordering Parts. When ordering replacement parts from Tektronix, Inc. include the following information:

1. Instrument type
2. Instrument serial number
3. A description of the part (if electrical, include circuit number)
4. Tektronix Part Number

Soldering Techniques

WARNING

Disconnect the instrument from the power source before soldering.

Circuit Boards. Use the procedures given under Component Replacement to remove the boards from the instrument before soldering. Use ordinary 60/40 solder and a 35- to 40-watt pencil type soldering iron on the circuit boards. The tip of the iron should be clean and properly tinned for best heat transfer to the solder joint. A higher wattage soldering iron may separate the wiring from the base material.

The following technique should be used to replace a component on a circuit board.

1. Grip the component lead with long-nose pliers. Touch the soldering iron to the lead at the solder connections. Do not lay the iron directly on the board as it may damage the board.

2. When the solder begins to melt, pull the lead out gently. This should leave a clean hole in the board. If not, poke a sharp object such as a toothpick into the hole to clean it out. A vacuum-type desoldering tool can also be used for this purpose.

3. Bend the leads of the new component to fit the holes in the board. Insert the leads into the holes in the boards so the component is firmly seated against the board, or as positioned originally. If it does not seat properly, heat the solder and gently press the component into place.

4. Touch the iron to the connection and apply a small amount of solder to make a firm solder joint; do not apply too much solder. To protect heat-sensitive components, hold the lead between the component body and the solder joint with a pair of long-nose pliers or other heat sink.

5. Clip the excess lead that protrudes through the board.

6. Clean the area around the solder connection with a flux-remover solvent. Be careful not to remove information printed on the board.

Metal Terminals. When soldering metal terminals (e.g., potentiometers, etc.), ordinary 60/40 solder can be used. Use a soldering iron with a 40- to 75-watt rating and a 1/8-inch wide wedge-shaped tip.

Observe the following precautions when soldering metal terminals:

1. Apply only enough heat to make the solder flow freely. Use a heat sink to protect heat-sensitive components.

2. Apply only enough solder to form a solid connection. Excess solder may impair the function of the part.

3. If a wire extends beyond the solder joint, clip off the excess.

4. Clean the flux from the solder joint with a flux-removing solvent.

Component Replacement

WARNING

Disconnect the instrument from the power source before replacing components.

General. The exploded-view drawings associated with the Mechanical Parts List (located on back of diagram pull-out pages) may be helpful in the removal or disassembly of individual components or sub-assemblies.

Circuit Board Replacement. If a circuit board is damaged beyond repair, either the entire assembly including all soldered on components, or the board only, can be replaced. Part numbers are given in the Mechanical Parts List for either the completely wired or the unwired board. Use the following procedure to remove the plug-on circuit boards.

1. Disconnect any pin connectors located on the front of the board.
2. Loosen all of the securing screws on the board.
3. Pull out on the edges of the board until the board clears the chassis terminals. Attempt to lift the board away from the chassis in such a way that it remains parallel to the chassis at all times so as not to bend the interconnecting terminals.
4. To replace a plug-on circuit board, position it so the securing screw holders mate with the guide posts on the chassis.
5. Gently press the circuit board against the chassis. Be sure that all of the interconnecting pins and sockets have properly mated.
6. Uniformly tighten the securing screws. Recommended torque, four to six inch-pounds.

Circuit Board Pin Replacement. It is important not to damage or disturb the ferrule when removing the old stub of a broken pin. The ferrule is swaged into the circuit board and provides a base for soldering the pin connector. If the broken stub is long enough, grasp it with a pair of needle nose pliers, apply heat with a small soldering iron to the pin base or the ferrule so a firm pull is required to pull it out. If the broken stub is too short to grasp with pliers, use a small dowel (0.028 inches in diameter) clamped in a vise to push the pin out of the ferrule after the solder has been heated. The old ferrule can be cleaned by reheating the solder and placing a sharp object such as a toothpick or small dowel into the hole. A vacuum-type solder removing tool is also useful for removing excess solder. Use a pair of diagonal cutters to remove the ferrule from the new pin, then insert the pin into the old ferrule, and solder the pin to both sides of the ferrule. If it is necessary to bend the new pin, grasp

the base of the pin with needle nose pliers and bend against the pressure of the pliers to avoid breaking the board around the ferrule.

Circuit Board Pin Socket Replacement. The pin sockets on the circuit boards are soldered to the rear of the board. To replace one of these sockets, first unsolder the pin (use a vacuum-type desoldering tool to remove excess solder). Then straighten the tabs on the socket and remove it from the hole in the circuit board. Place the new socket in the circuit board hole and press the tabs down against the board. Solder the tabs of the socket to the circuit board; be careful not to get solder into the socket.

NOTE

The spring tension of the pin sockets ensures a good connection between the circuit board and the pin. This spring tension can be destroyed by using the pin sockets as a connecting point for spring-loaded probe tips, alligator clips, etc.

End-Lead Pin Connector Replacement. The pin connectors used to connect the wires to the interconnecting pins are clamped to the ends of the associated leads. To replace damaged end-lead pin connectors, remove the old pin connector from the end of the lead and clamp the replacement connector to the lead. Some of the pin connectors are grouped together and mounted in a plastic holder; the overall result is that these connectors are removed and re-installed as a multi-pin connector. To provide correct orientation of this multi-pin connector when it is replaced, an arrow is stamped on the circuit board or chassis and a matching arrow is molded into the plastic housing of the multi-pin connector. Be sure these arrows are aligned as the multi-pin connector is replaced. If the individual end-lead pin connectors are removed from the plastic holder, note the color of the individual wires for replacement.

Tunnel Diode CR28 Replacement. Locate the clip shown in Fig. 4-3A on your trigger board. Leadless capacitor C27 and tunnel diode CR28 are located under this clip. Fig. 4-3B shows that one side of C27 is soldered to the 50 Ω stripline. A 0.3 inch length of 3/1000 inch diameter wire, that serves as inductor L27, is connected from the 50 Ω stripline to relay K31. Be careful not to disturb this wire when replacing CR28 since the fine wire is easily broken.

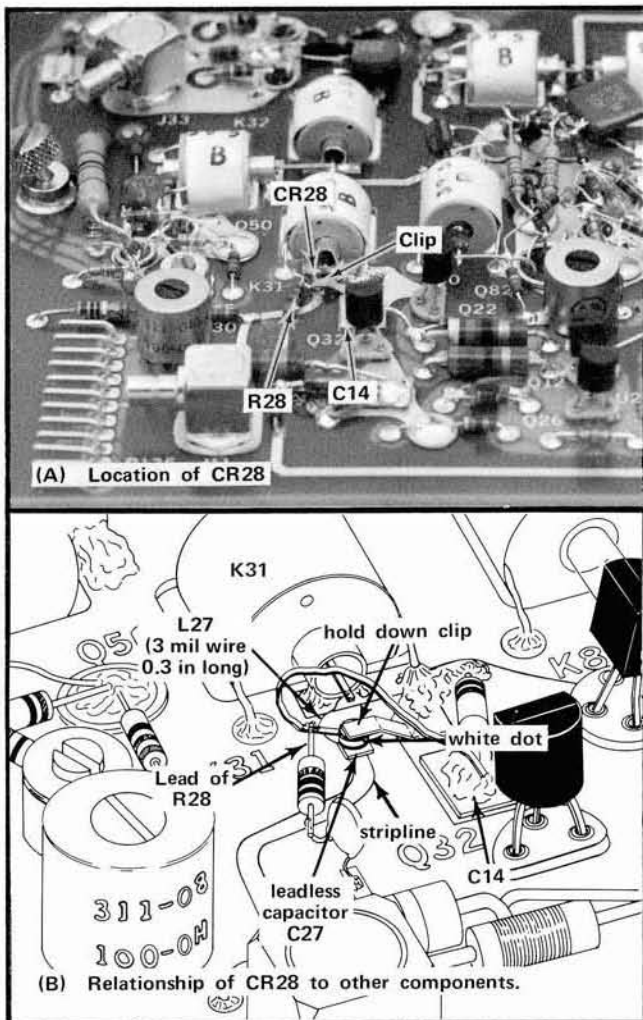

Fig. 4-3. The 200 MHz oscillator tunnel diode (CR28).

The tunnel diode is positioned between C27 and the hold-down clip. The clip, together with the support provided by the lead of resistor R28, holds the tunnel diode in place. The lead from the anode of CR28 is formed into a loop (shown as L23 on the Trigger Input schematic) and the lead end is soldered to leadless capacitor C14.

Carefully unsolder the tunnel diode lead from C14 using a 15-watt soldering iron and a pair of tweezers. Next unsolder R28 from C28. Use tweezers to carefully remove the tunnel diode from underneath the clip. Protect CR28 with a heat sink and unsolder R28 from the tunnel diode lead.

Determine the cathode side of the new tunnel diode before soldering R28 to the tunnel diode lead. The cathode is indicated by a white dot (see Fig. 4-3B). Clip off the lead

connected to the tunnel diode cathode. Heat sink the tunnel diode and solder R28 to the tunnel diode anode lead. Carefully slip the tunnel diode under the hold down clip with the cathode side up. Resolder R28 to C28 and solder the extreme end of the tunnel diode lead to C14.

The free run frequency of the 200 MHz oscillator is increased as more of the tunnel diode lead length is soldered to C14. The shape of the loop formed by the tunnel diode lead also has some effect on the oscillator frequency.

Set the HF Sync adjustment (R10) to the minimum bias current setting providing a stable display at all settings of the Stability control. Reducing the tunnel diode bias current increases the oscillator frequency range. Adjustment of R10 is explained in Section 5 of this manual.

The frequency change provided by the Stability and Trigger Level controls must be at least the amount shown in Fig. 4-4. If the oscillator frequency is 220 MHz with the Stability and Trigger Level controls fully CCW, an oscillator frequency range of at least 55 MHz is required to ensure countdown on all frequencies from 1 GHz to 12.4 GHz. Turning the Stability and Trigger Level controls fully CW (in this example) must result in an oscillator frequency of 275 MHz or higher.

If the minimum oscillator frequency (controls CCW) is 250 MHz or higher, a large oscillator frequency range is required. To ensure that oscillator frequency range requirements are met, it is recommended that the minimum oscillator frequency (Stability and Trig. Level CCW) be 245 MHz or lower. As previously mentioned, lengthening the unsoldered portion of the tunnel diode lead (CR28) will reduce the oscillator frequency.

Switch Replacement. Two types of switches are used in the 7T11. The pushbutton switches and the cam-type switch should be replaced as a unit if damaged. The following special maintenance information is provided for the cam-type and pushbutton type switches.

CAUTION

Repair of the cam switch should only be undertaken by skilled maintenance personnel. Switch alignment and contact spacing must be carefully maintained for proper operation of the switch. The cam switch repair kit contains special alignment tools for use in repair-

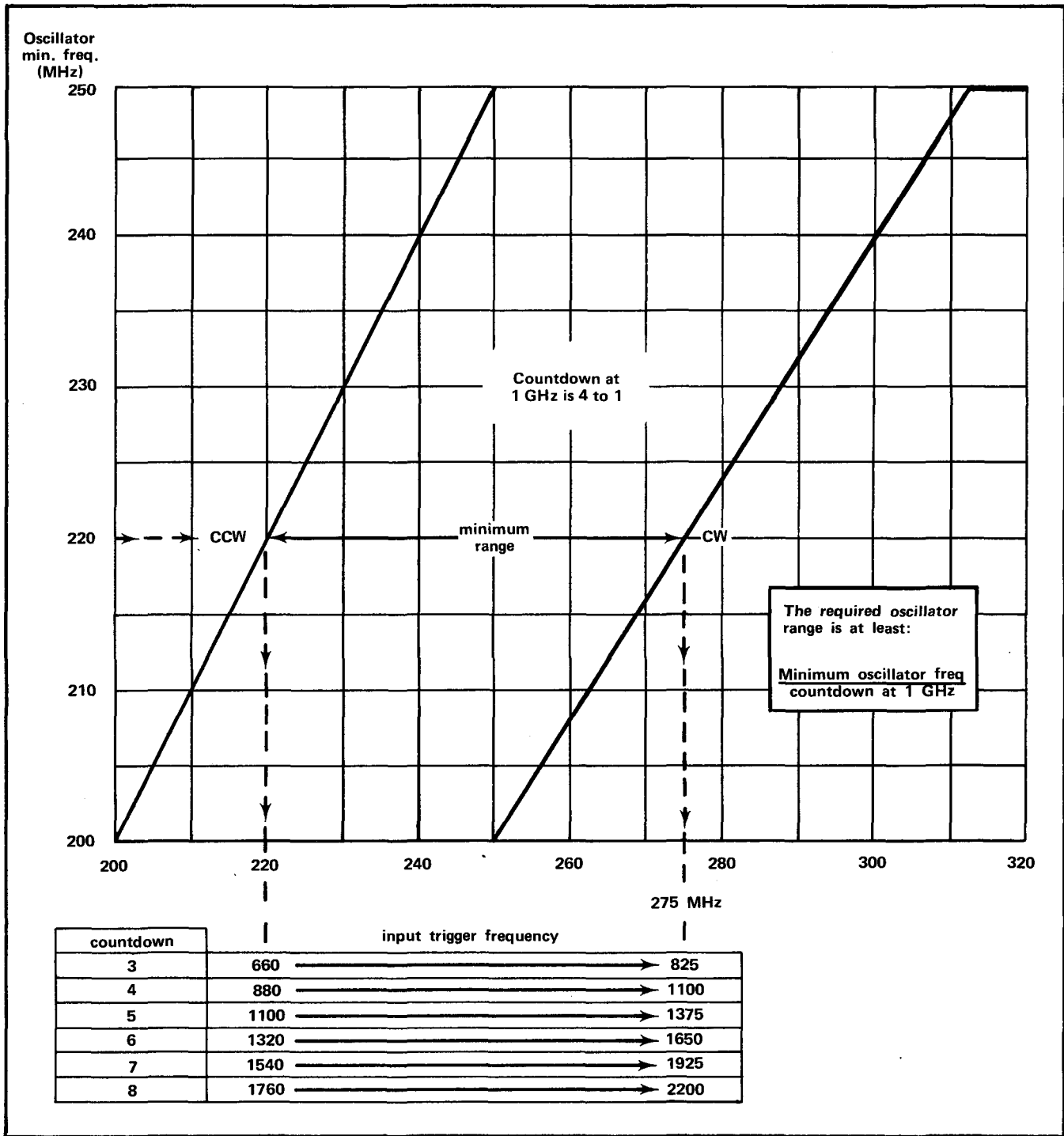

Fig. 4-4. Minimum range required for the 200 MHz oscillator.

ing or replacing the cam and contacts. For information or assistance on maintenance of the cam switch contact your local Tektronix Field Office or representative.

A. CAM-TYPE SWITCH. The cam-type switch (TIME/DIV) consists of a rotating cam, which is turned by the front panel knob, and a set of contacts mounted on an adjacent circuit board. These switch contacts are actuated

by lobes on the cam. The TIME/DIV switch can be disassembled for inspection, cleaning, repair or replacement as follows:

1. Remove the two screws holding the metal covers on each of the switches. The front switch section is the TIME/DIV switch and the rear switch section is the TIME POS RNG switch. The switches are now open for inspection or cleaning.

2. To completely remove either of the switches from the board, loosen the hex-socket screws (use a 0.035-inch hex-key wrench) in the shaft at the front of the rear switch section and a hex-socket screw (use a 0.050-inch hex-key wrench) at the rear of the rear switch. Pull both long shafts out of the switch assembly.

3. The rear switch can be removed by removing four screws which hold the cam switch to the circuit board (from the rear side of board).

4. The front switch can be removed by first removing the remaining knob (use a 1/16-inch hex-key wrench) and nut holding the switch shaft to the front panel. Remove the four screws which hold the cam switch to the circuit board (from the rear side of board).

5. To remove the cam from the front support block, remove the retaining ring from the shaft on the front of the switch and slide the cam out of the support block. Be careful not to lose the small detent roller.

6. To replace defective switch contacts, unsolder the damaged contact and clean the solder from the hole in the circuit board. Then, position the new contact in the hole so it is properly aligned in relation to the other switch contacts and the mating area on the circuit board (alignment tool provided in switch repair kit). Solder the new contact into place; be sure that the spring end of the contact has adequate clearance from the circuit board.

7. To re-install the switch assembly, reverse the above procedure.

B. PUSHBUTTON SWITCHES. Use the following procedure to replace any of the pushbutton switches.

1. Loosen the set screws and remove all the front panel knobs.

2. Remove any other nut or part holding the front panel to the instrument.

3. Remove the front panel to gain access to the switch mounting screws.

4. To remove any of the pushbutton switches, remove the phillips head screws from each of the switches to be removed. Unsolder and remove any wire connected to the switch circuit board and carefully note where it belongs. See Fig. 4-5 and 4-6.

Light Bulb Replacement. To replace the light bulbs, follow the above procedure to remove the switches. Remove the screw and cover from the back of the switch to expose the light bulb. Unsolder the two leads and remove the light bulb. Cut the leads of the replacement light bulb to the same length as those of the old bulb. Place insulated sleeves over the leads and replace the new bulb in the exact position of the old bulb.

Reassemble by reversing the above procedure.

Instrument Repackaging

NOTE

The plug-in should not be shipped in an oscilloscope. The oscilloscope packaging material is not designed to protect the plug-ins.

If the 7T11 is to be shipped for long distances by commercial means of transportation, it is recommended that the instrument be repackaged in the original manner for maximum protection. The original shipping carton can be saved and used for this purpose. Repackaging information and/or new shipping cartons can be obtained from Tektronix, Inc. Contact your local Tektronix Field Office or representative. Tektronix, Inc.

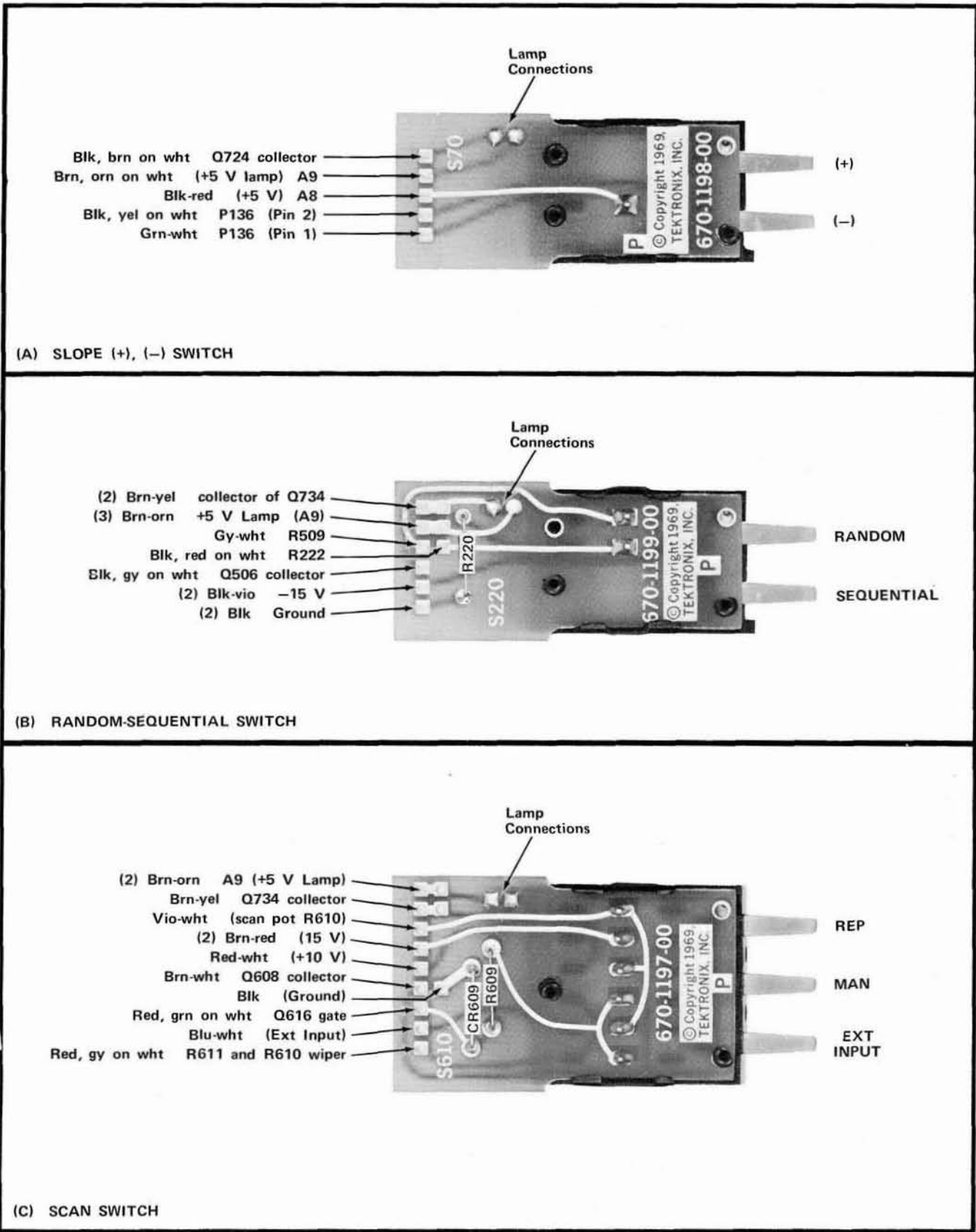
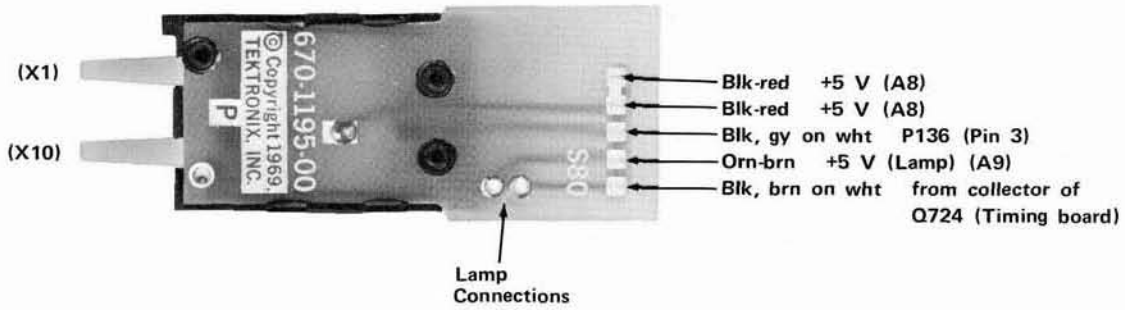
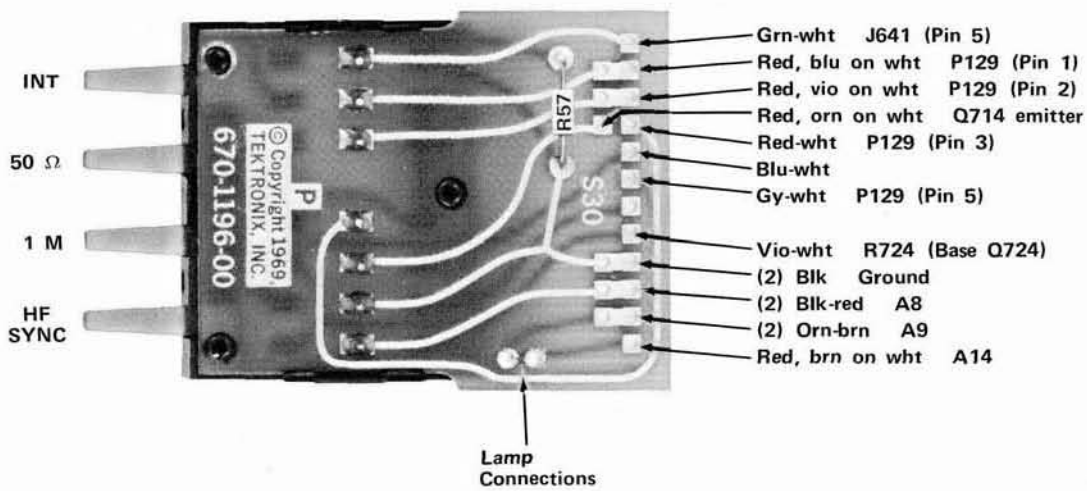

Fig. 4-5. Connections to circuit boards of the SLOPE, RANDOM-SEQUENTIAL, and SCAN switches.



(A) TRIGGER AMP Switch (Right side)



(B) INT - EXT Trigger Switch (Right side)

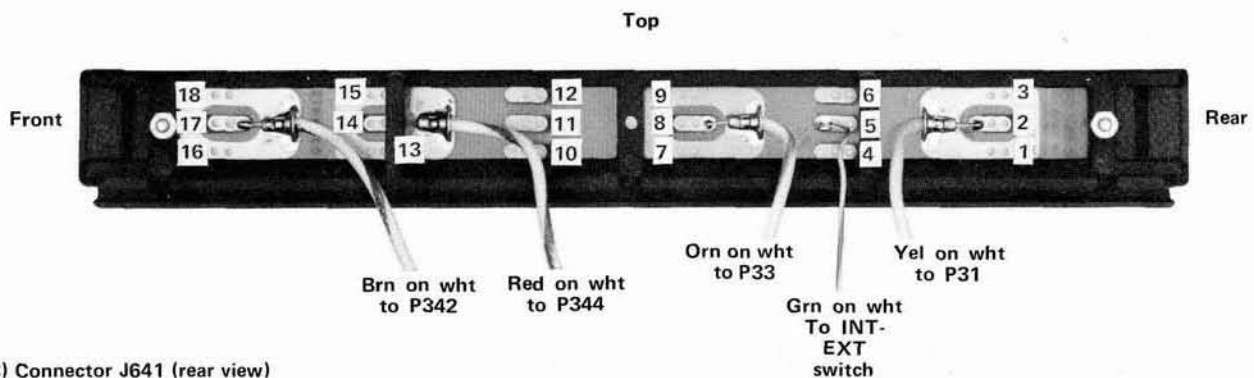

(C) Connector J641 (rear view)

Fig. 4-6. Connections to circuit boards of the TRIGGER AMP and INT-EXT switches, and connector J641.

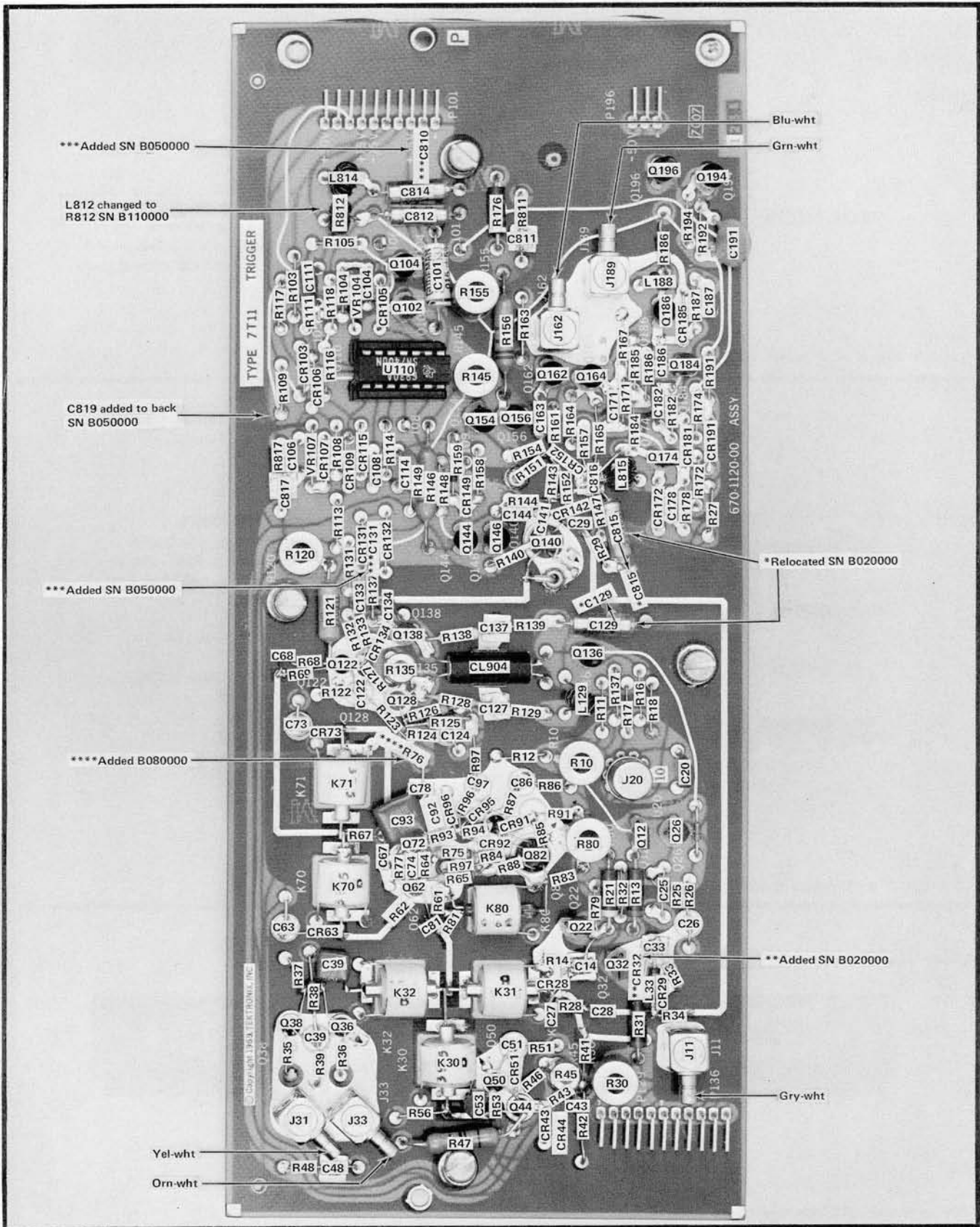

Fig. 4-7. Trigger Circuit board (front view) showing location of components and connector color-coding.

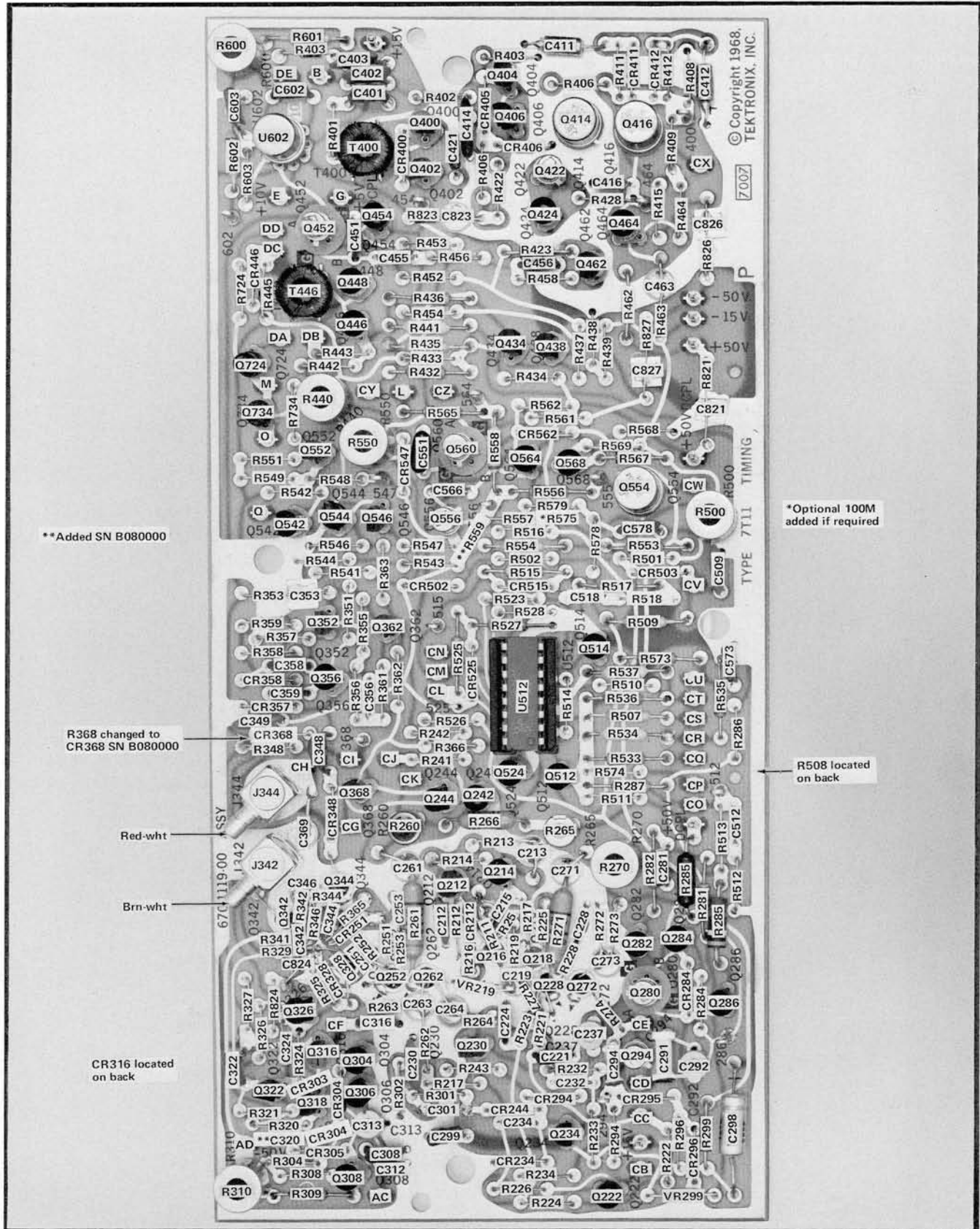

Fig. 4-8. Timing Circuit board (front view) showing location of components and connector color-coding.

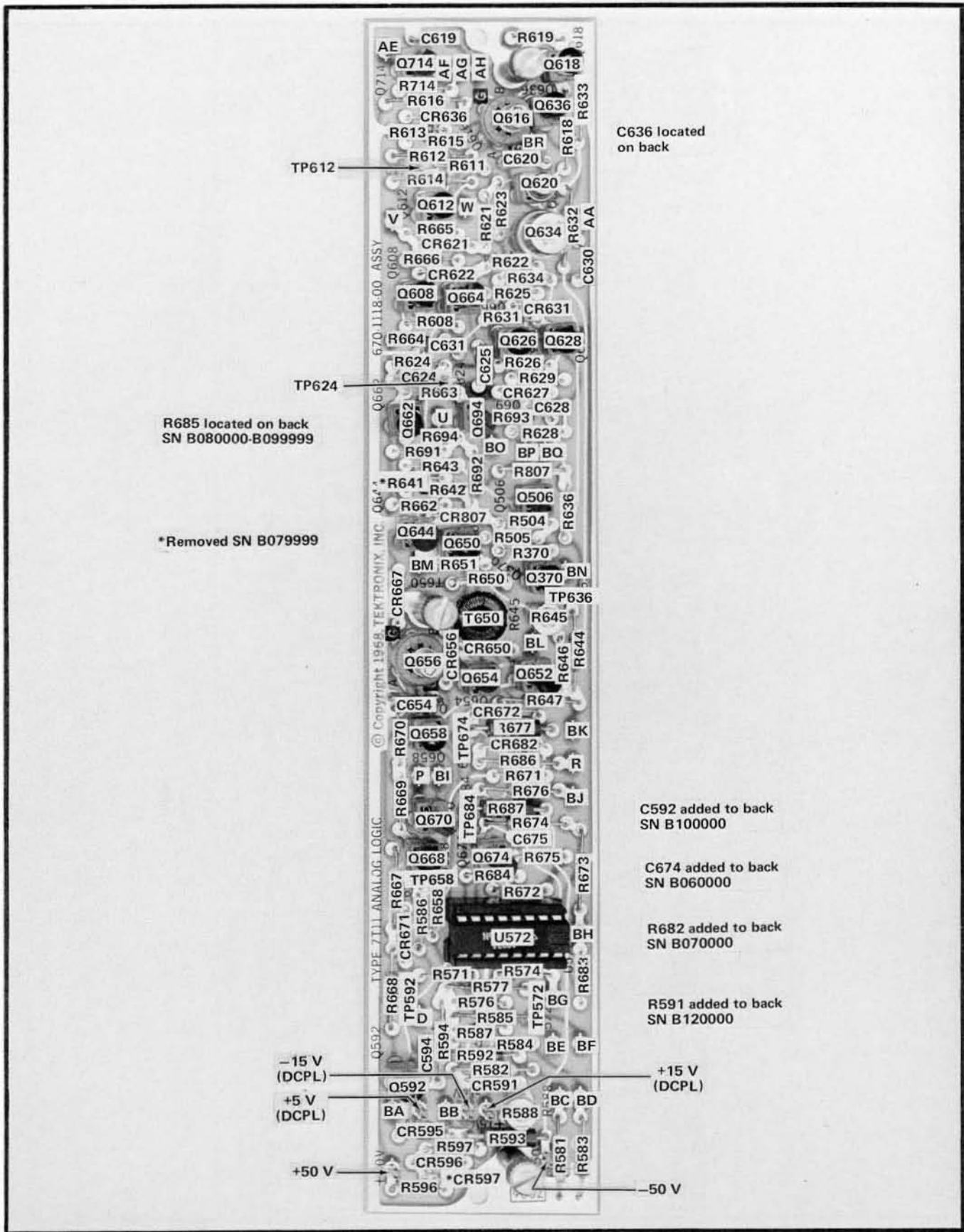

Fig. 4-9. Analog Logic Circuit Board (front view) showing location of components and pin identification.

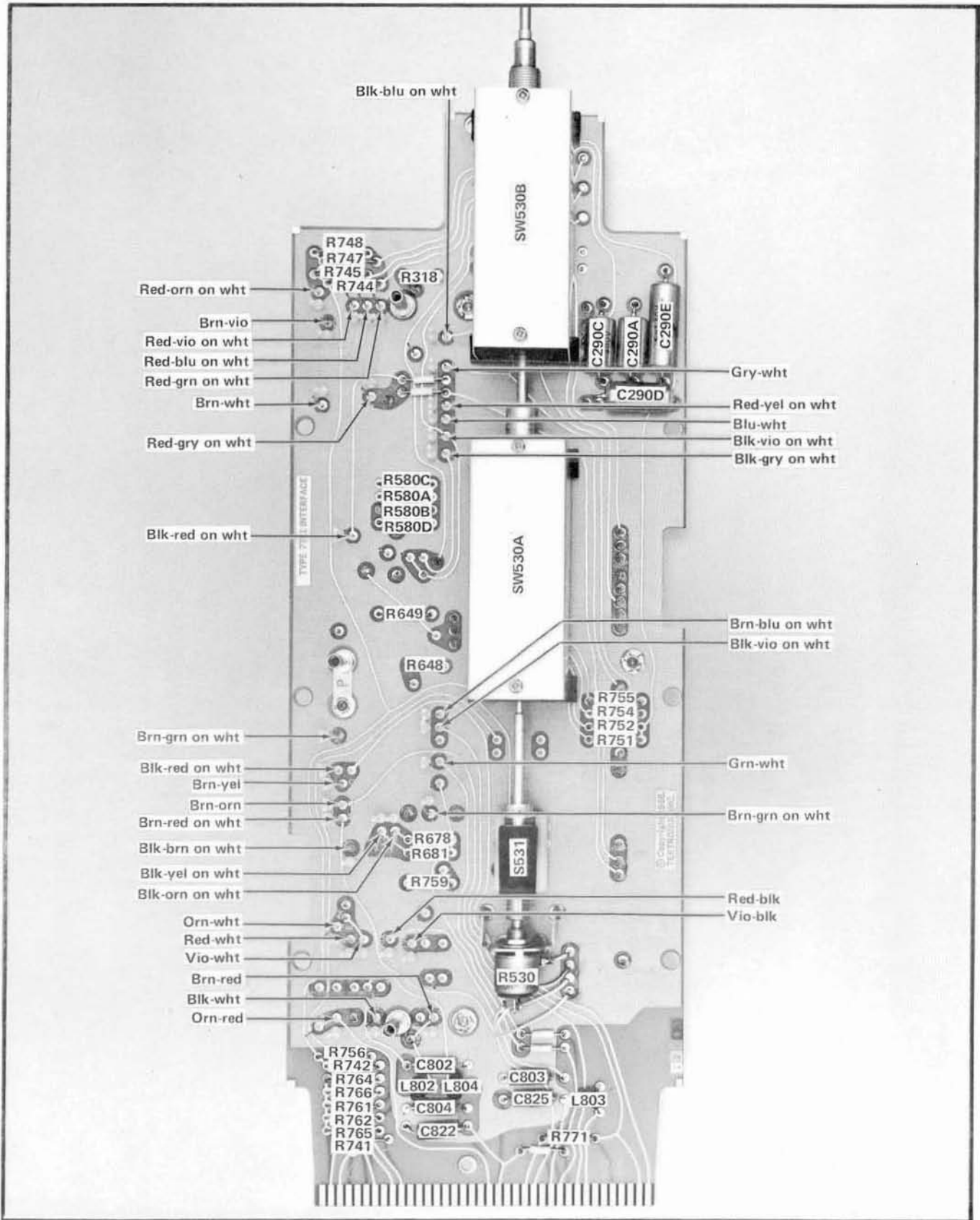

Fig. 4-10. Interface Board (left side) showing location of components and wire color-coding.

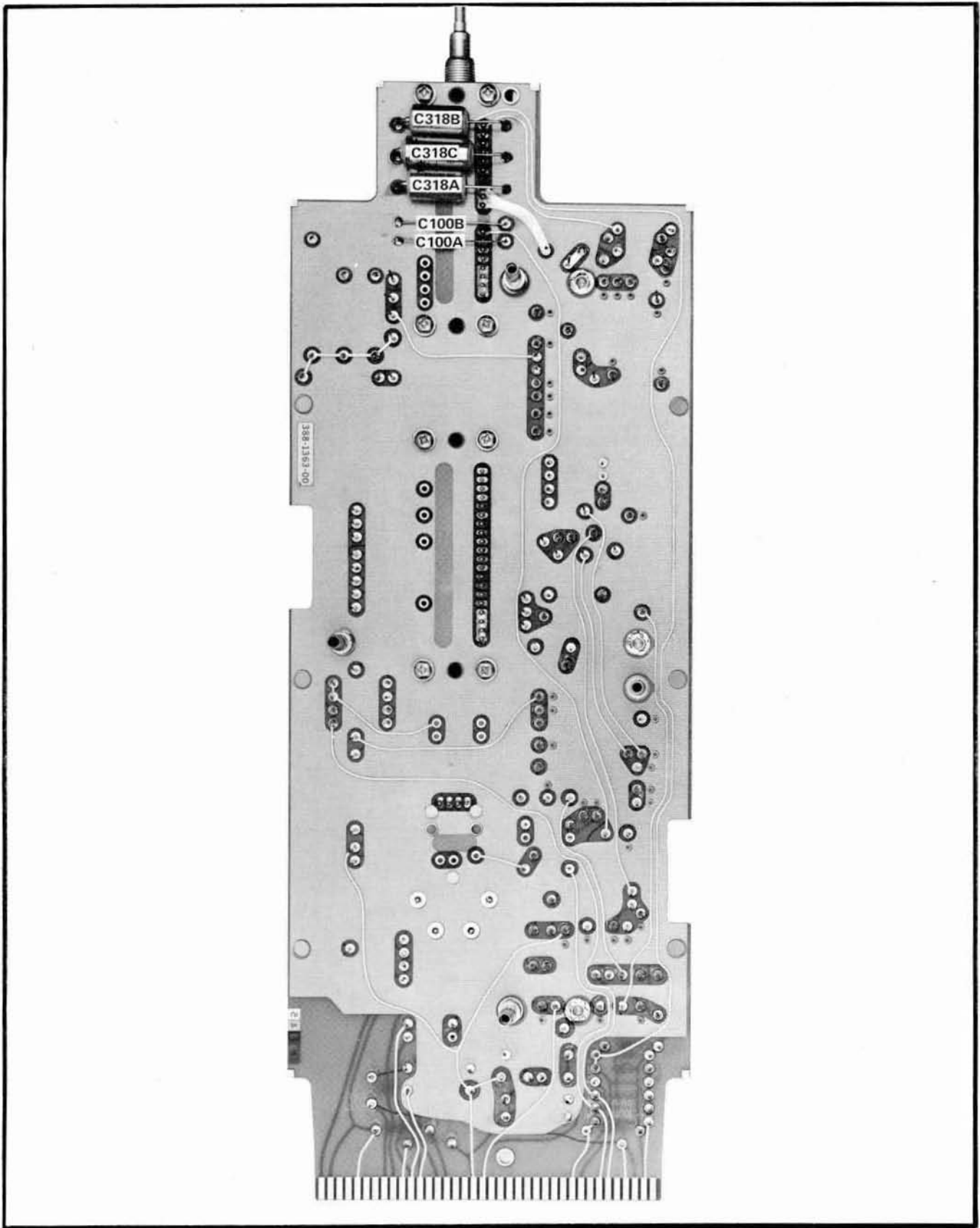

Fig. 4-11. Interface Board (right side) showing location of components.

SECTION 5

PERFORMANCE CHECK / CALIBRATION

Change information, if any, affecting this section will be found at the rear of the manual.

Introduction

This procedure combines the 7T11 performance check and calibration procedures, since a number of the steps are common to both procedures. The Performance Check Procedure (using the test equipment recommended and without access to internal controls or test points) includes all the steps that can be done on the 7T11 when it is installed in the oscilloscope. Notes in the text titled "Performance Check Only" give instructions that pertain to the performance check procedure only and list the next step applicable to the performance check. All steps pertain to the calibration procedure.

As an aid to calibration of the instrument, a Short-Form Procedure is given prior to the complete procedure. To facilitate instrument calibration for the experienced calibrator, the Short-Form Procedure lists the calibration adjustments necessary for each step and the applicable tolerances. This procedure also includes the step number and titles as listed in the complete Performance Check/Calibration Procedure and the page number on which each step begins. Therefore, the Short-Form Procedure can be used as an index to locate a step in the complete procedure. This procedure can be reproduced and used as a permanent record of instrument calibration.

Completion of each step in the complete Performance Check/Calibration Procedure ensures that this instrument meets the electrical specifications given in Section 1. Where possible, instrument performance is checked before an adjustment is made. For best overall instrument performance when performing a complete calibration procedure, make each adjustment to the exact setting, even if the check is within the allowable tolerance.

NOTE

All waveforms shown in this procedure were taken with a Tektronix Oscilloscope Camera System. Limits, tolerances and waveforms in this procedure are given as calibration guides and should not be interpreted as instrument specifications except as specified in Section 1.

TEST EQUIPMENT REQUIRED

General

The following test equipment and accessories, or equivalent, are required for complete calibration of the

7T11. Specifications given are the minimum necessary for accurate calibration. Therefore, some of the recommended equipment may have specifications which exceed those given. All test equipment is assumed to be correctly calibrated and operating within the given specifications. If equipment is substituted, it must meet or exceed the specifications of the recommended equipment.

Special Tektronix Calibration fixtures are used in this procedure only where they facilitate calibration. These special calibration fixtures are available from Tektronix, Inc. Order by part number through your local Tektronix Field Office or representative.

Test Equipment

1. Oscilloscope; 7504 or 7704, in which to operate the 7T11.
2. 7S11 Sampling Unit.
3. Sampling Head operated in the 7S11. The Type S-1 Sampling Head is used in this procedure.
4. Test oscilloscope with comparator, minimum deflection factor of 2 mV/div or less, and risetime of 20 ns or less. A 7A13 Differential Comparator and 7B50 Time Base can be operated in the 7504 Oscilloscope required for the 7T11. A separate test oscilloscope such as the Type 547 with the Type W Plug-In Unit may be used.
5. 1X Probe, P6011. Tektronix Part No. 010-0193-00.
6. 10X Probe, P6012. Tektronix Part No. 010-0203-00.
7. Time-Mark Generator, Tektronix 2901. Minimum alternate requirements: Marker or sine wave output of 10 ms, 5 ms, .5 ms, 50 μ s, 5 μ s, 1 μ s, .5 μ s, .1 μ s, 50 ns, 10 ns, and 5 ns with an accuracy within $\pm 0.3\%$.
8. Constant Amplitude Signal Generator, Tektronix Type 191. Minimum alternate requirements: Frequencies of 350 kHz at 25 mV, 50 MHz and 100 MHz with an output amplitude variable from about 5 mV to 2 V into 50 Ω .

Performance Check/Calibration—7T11

9. UHF Oscillator such as General Radio Type 1361-A with a General Radio Regulated Power Supply Type 1201-B. Minimum alternate requirements: Output frequencies of 500 MHz and 1 GHz with an output amplitude variable from about 5 mV to 2 V.

10. Low Frequency Oscillator such as a General Radio Type 1310-A. Minimum alternate requirements: Output frequencies of 2 hertz to 5 kilohertz with up to 2 volts output amplitude peak to peak into 50 ohms. (Use a General Radio Type 2740BJ Adapter to provide BNC output.)

11. Delay Line (50 Ω) providing at least 75 ns of delay such as the Tektronix 7M11.

12. Pulse Generator such as Tektronix Type S-50 providing a 25 ps risetime, 400 mV pulse into 50 Ω.

13. 2 ns coaxial cable with GR874 connectors, such as RG58C/U cable, Tektronix Part No. 017-0505-00.

14. 5 ns coaxial cable with GR874 connectors, such as RG58C/U cable, Tektronix Part No. 017-0512-00.

15. 50 Ω Power Divider with GR874 connectors. Tektronix Part No. 017-0082-00.

16. 50 Ω Termination with GR874 connectors. Tektronix Part No. 017-0081-00.

17. 50 Ω 10X attenuator with GR874 connectors. Tektronix Part No. 017-0078-00.

18. 3 mm male to GR874 adapter. Tektronix Part No. 015-1007-00, supplied with the 7T11.

19. Extender (rigid), Tektronix Calibration Fixture 067-0589-00, or Extender (flexible), Tektronix Calibration Fixture 067-0616-00.

20. Special cable assembly, RF, about 36 inches in length with coaxial connectors. Tektronix Part No. 012-0203-00.

21. 5/16 inch wrench, such as Armstrong No. 1120. Tektronix Part No. 003-0260-00.

22. Screwdriver. Three-inch shaft, 3/32-inch blade width for slotted screws and adjustments. Tektronix Part No. 003-0192-00.

23. Plastic tool for adjusting sensitive capacitors, such as Walsco No. 2543 or Tektronix Part No. 003-0301-00.

24. BNC T connector. Tektronix Part No. 103-0030-00.

25. 50 Ω 5X attenuator with BNC connectors, Tektronix Part No. 011-0060-01.

26. BNC Female to GR874 adapter, Tektronix Part No. 017-0063-00.

27. 50 Ω coaxial cable about 42 inches long with BNC connectors, Tektronix Part No. 012-0057-01, supplied with the 7T11.

28. BNC Male to GR874 adapter, Tektronix Part No. 017-0064-00.

29. BSM Male to BNC Female adapter, Tektronix Part No. 103-0036-00.

30. 50 Ω termination with BNC connectors, Tektronix Part No. 011-0049-01.

31. 3 mm Male to BNC Female adapter, Tektronix Part No. 015-1018-00, supplied with the 7T11.

32. Patch cord with phone tips for front panel jack connections, such as a Simpson meter lead, Tektronix Part No. 003-0400-00.

33. Optional equipment: Tektronix Type S-4 Sampling Head and Signal Generator such as the Hewlett-Packard, HP626A. This generator is required only to check HF SYNC triggering at a frequency of 12.4 GHz.

SHORT-FORM PROCEDURE

7T11, Serial Number _____

Calibration Date _____

Calibrated By _____

- 1. Adjust +10 Volts R600
+10.00 volts at test point 602.

2. Check Manual Scan and Adjust Sweep Cal and Position Page 5-7
SWEEP CAL and POSITION controls have 1 division range; MANUAL SCAN has 10 division range.
3. Check Timing Accuracy Page 5-7
Correct timing within 3%.
4. Check Time Position Ranges Page 5-9
Full range of both TIME POSITION controls within 5% of SWEEP RANGE setting; FINE control range at least 0.9% of the SWEEP RANGE setting.
5. Adjust Timing, R260, R265 and C292 Page 5-9
Correct timing at SWEEP RANGE switch settings 50 ms, .5 ms and 50 ns.
6. Adjust R500, R550, R310, C313, R588, C237, R440 and R645 Page 5-10
Correct trace and marker positioning; no trace or dot movement with rotation of TIME POSITION or SWEEP RANGE controls.
7. Adjust Random Timing R270 Page 5-11
No pulling in the display.
8. Adjust Trig Level Page 5-12
TRIG LEVEL control with dot straight up provides same voltage at junction of R68-R69 for both + and – settings of SLOPE switch.
9. Adjust Stability R135 and Trig Level Zero R120 Page 5-12
Trace is off with STABILITY control fully counterclockwise and starts to oscillate with 60° to 90° of clockwise rotation of the STABILITY control.
10. Adjust External Trigger Zero, R80 and R45 Page 5-13
Zero volts at junction of R94-R93, EXT 50 Ω 2 V MAX setting; and at junction of R53-R56 with EXT 1 MAX setting.
11. Adjust HF Sync, R10 and R30 Page 5-13
10 MHz signal at junction of R34-L33; kickout pulse repetition rate between 205 MHz and 245 MHz with fully counterclockwise settings of TRIG LEVEL and STABILITY controls, increasing by 25% at fully clockwise settings.
12. Adjust Output Bias R155 and Arming Bias R145 Page 5-14
Arming Bias R145 set about 90° from fully clockwise setting; output Bias set midrange between signal 3-5 ns position change and trace stopping.
13. Check Triggering Capability Page 5-15
Check that triggering is stable on all triggering modes at the specified input voltages and frequencies.
14. Check Display Jitter Page 5-16
Check jitter during Sequential, Random, and Real Time operation at the required sweep rates.
15. Check Source of Jitter Page 5-18
This is optional check and is not required if the display jitter determined in Step 14 is not excessive.
16. Check Pulse Out into 50 Ω Page 5-19
Amplitude at least 400 mV and risetime is 2.5 ns or less.
17. Check Trigger Kickout Page 5-19
Kickout pulse amplitude 1 mV or less.
18. Check Trigger Holdoff Page 5-20
Correct trigger holdoff on all SWEEP RANGE switch settings, Table 5-3.
19. Check Strobe Kickback into Trigger Page 5-20
Vertical amplitude of largest discontinuity with 25 mV signal amplitude is 3 mV or less.
20. Check Minimum Trigger Rate in Random Mode Page 5-21
Sweep is triggered by 100 Hz frequency.

Performance Check/Calibration—7T11

21. Check Repetitive Scan Rate Page 5-21

SCAN control changes SWEEP OUT time from 25 ms or less to 500 ms or more.

22. Check Sweep Out Range Page 5-21

SCAN control changes SWEEP OUT voltage from +5 volts through -5 volts.

23. Check External Input Page 5-21

10 volts applied at EXT INPUT jack give 10 division dot movement with rotation of SCAN control.

PERFORMANCE CHECK/ CALIBRATION PROCEDURE

General

The following procedure is arranged so the 7T11 can be calibrated with the least interaction of adjustments and reconnection of equipment. A picture of the test equipment required for each group of steps is given to aid in identification of the necessary equipment. The control settings and test equipment setup throughout this procedure continue from preceding step(s) unless noted otherwise.

NOTE

Control titles which are printed on the front panel of the 7T11 are capitalized in this procedure (e.g., TIME POSITION). Internal adjustments are initial capitalized only (e.g., Trig Level Zero).

The following procedure uses the equipment listed under Test Equipment Required. If other equipment is substituted, control settings or calibration setup may need to be altered to meet the requirements of the equipment used. Detailed operating instructions for the test equipment are not given in this procedure. Refer to the instruction manual for the test equipment if more information is required.

NOTE

Many tolerances given in this procedure are guides to correct instrument operation and are not instrument specifications.

Performance Check

Install the 7A13 in the Oscilloscope Left Vert compartment; the 7S11, with the Sampling Head installed in the Right Vert compartment; the 7T11 in the A Horiz compartment, and the 7B50 in the B Horiz compartment.

Begin the performance check with step 2.

Calibration Procedure

a. Install the 7A13 in the Oscilloscope Left Vert compartment and the 7B50 in the B Horiz compartment.

b. Remove the side panel covers on the 7T11 and the 7S11.

c. Remove the 5/16-inch nut on the front panel TRIG INPUT connector and remove the connector from the front panel.

d. Loosen the four screws holding the Trigger Board and lift the Board so it can be supported by the top chassis channel, see Fig. 5-1A.

e. Remove the coaxial cable at J344, top of the 7T11, and the coaxial cable on the 7S11 Inter-Channel Control Board. Connect the RF cable assembly between the 7T11 J344 connector and the 7S11 Sampling Drive connector, with the cable threaded through the 7S11 switch portion from the right side. Tape the loose connector to the chassis to avoid a short circuit. See Fig. 5-1B. This completes oscilator control and strobe drive circuits.

f. Install the 7S11 (with the Type S-1 installed) in the Oscilloscope Right Vert compartment and the 7T11 on the extender in the A Horiz compartment.

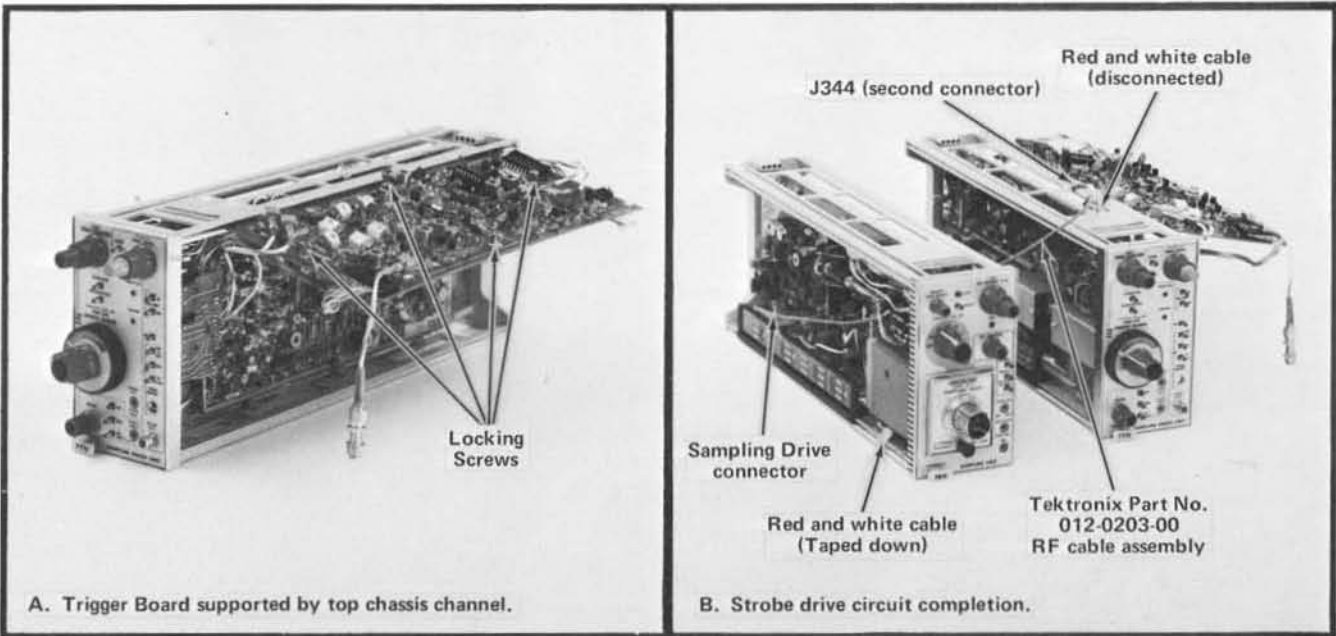

Fig. 5-1. Board placement and connections for calibration.

NOTES

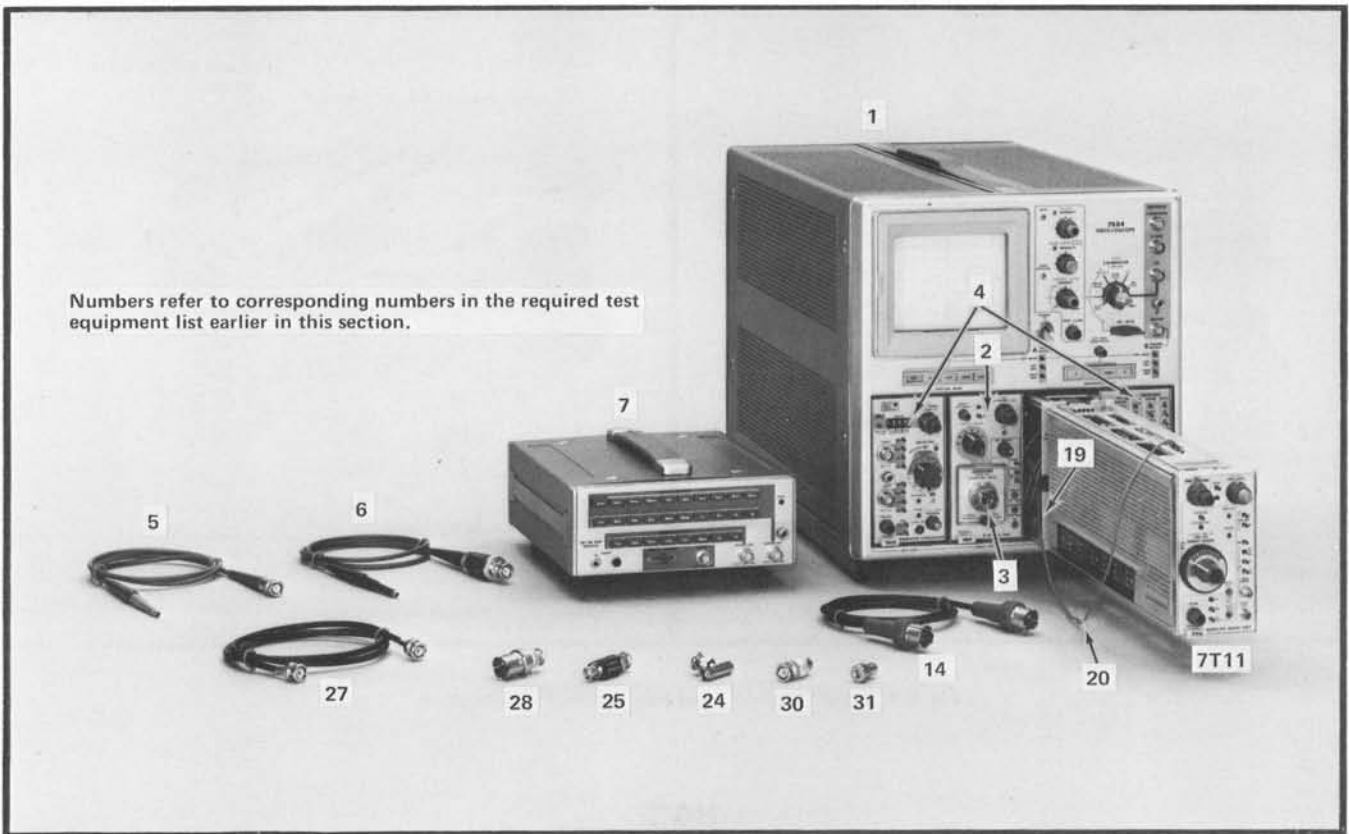

Fig. 5-2. Test equipment required for steps 1 through 12.

Both Procedures

Make all power connections. Turn on the power to all equipment. Allow 20 minutes warmup time before proceeding. Set the controls as listed under Preliminary Control Settings; see Fig. 5-2.

Preliminary Control Settings

7504 Oscilloscope

Vertical Mode	Left
A Trigger Source	Right
Horizontal Mode	B
B Trigger Source	Left Vert

Other controls may be in any position. Set the Intensity and Focus controls for a well defined trace or display.

7A13 Differential Comparator

+	Pushed in
Comparison Voltage (Vc)	10.00
+Input	DC
Volts/Div	0.1
-Input	GND
BW	Full

7S11 Sampling Unit

+Up	Pushed in
DC Offset	Centered display
mVolts/Div	200
Dot Response	Midrange
Normal	Pushed in

7T11 Sampling Sweep Unit

TIME POSITION	Fully clockwise
SLOPE	—
TRIG LEVEL	Midrange
STABILITY	Fully clockwise
SEQUENTIAL	Pushed in
TRIG AMP	X1
SWEEP RANGE	50 μ s
TIME/DIV	5 μ s
EXT	50 Ω 2 V MAX
SCAN	REP

7B50 Time Base

Level/Slope	For display
Mode	Auto
Coupling	AC
Source	Int

Magnifier X1
 Display Mode Time Base
 Time/Div 1 ms

1. Adjust +10 Volts (R600)

PERFORMANCE CHECK ONLY

Step 1 is not applicable to a performance check. Set the controls as given under Preliminary Control Settings and begin with step 2.

a. Set the 7A13 Position control so the trace is at the center of the graticule for reference. Connect a 1X probe at the +Input connector.

b. Connect the 1X probe tip to test point 602, on the Timing Board shown in Fig. 5-3, and set the -Input to Vc.

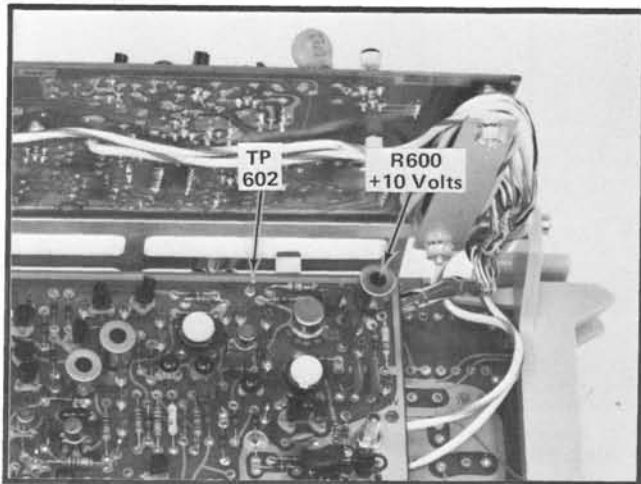

Fig. 5-3. +10 Volts adjustment and test point locations on Timing Board.

c. Adjust +10 Volts control R600 for 10.00 volts. See Fig. 5-3 for location.

d. Set the +Input and -Input to GND. Remove the probe tip.

2. Check Manual Scan and Adjust Sweep Cal and Position

a. Set the 7504 Oscilloscope Vertical Mode switch to Right and Horizontal Mode switch to A.

b. Center the trace with the 7S11 DC Offset control.

c. Push in the SCAN-MAN switch and turn the SCAN control fully clockwise to position the spot at the tenth graticule line.

d. Check the SWEEP CAL control (front-panel screw-driver adjustment) for 0.5 division range.

e. Turn the SCAN control fully counterclockwise to set the spot at the 0 graticule line and check the SWEEP CAL control for 0.5 division range.

f. Turn the SCAN control so the spot is at the center of the graticule.

g. Check the POSITION control (front-panel screw-driver adjustment) for a one-division range.

h. Set the SWEEP CAL and POSITION controls so the spot is at the 0 graticule line with the SCAN control fully counterclockwise, and at the tenth graticule line with the SCAN control fully clockwise.

i. Push in the SCAN REP switch.

3. Check Timing Accuracy

a. Connect the Time Mark Generator Marker Out connector to a 50 Ω BNC 5X attenuator and a BNC T con-

TABLE 5-1

Switch	Setting	Input Signal	Display	Sweep start excluded	Noted Tolerance
TIME/DIV (at 50 μs SWEEP/RANGE)	5 μs ¹	5 μs	1 marker/div	5 μs	
	2 μs	1 μs	2 markers/div		
	1 μs	1 μs	1 marker/div		
	.5 μs	.5 μs	1 marker/div		
	.2 μs	.1 μs	2 markers/div		
	.1 μs	.1 μs	1 marker/div		
	50 ns	50 ns	1 cycle/div		
	20 ns	10 ns	2 cycles/div		
	10 ns	10 ns	1 cycle/div		
	Reset to 5 μs				
SWEEP RANGE	5 μs ¹	.5 μs	1 marker/div	2.5 μs	
	.5 μs ¹	50 ns	1 cycle/div		
	50 ns ¹	5 ns	1 cycle/div		
	.5 ms	50 μs	1 marker/div		
	5 ms	.5 ms	1 marker/div		
50 ms	5 ms	1 marker/div	250 μs		

¹Check at both RANDOM and SEQUENTIAL switch settings.

Performance Check/Calibration—7T11

nector. Connect one side of the T to a BNC to GR874 adapter and coaxial cable to the Sampling Head Input connector; and the other side to a BNC coaxial cable and BNC to 3 mm adapter, then to the 7T11 TRIG INPUT connector.

b. Set the 7S11 Units/Div switch to 100.

c. Obtain a stable display with the TRIG LEVEL control and set the SCAN control as needed. Check the timing accuracy of the 7T11 according to Table 5-1, see Fig. 5-4. Check the timing with the TIME POSITION control turned counterclockwise to exclude the first part of the sweep as listed in Table 5-1. Make note of the tolerance at the TIME/DIV switch positions and compare to the SWEEP RANGE switch positions.

d. Check that the algebraic sum of the tolerances at all settings of the TIME/DIV and SWEEP RANGE switches are within $\pm 3\%$, (0.24 division measured over 8 divisions).

e. Push in the SEQUENTIAL switch. Set the SWEEP RANGE switch to 50 μs and the TIME/DIV switch to 0.5 μs . Apply 1 μs markers and observe 1 marker per 2 divisions on the CRT; see Fig. 5-4C.

f. Push the VARIABLE control for release; turn the control fully counterclockwise, and observe the marker display.

g. Check that the markers are at least 5 divisions apart; see Fig. 5-4D.

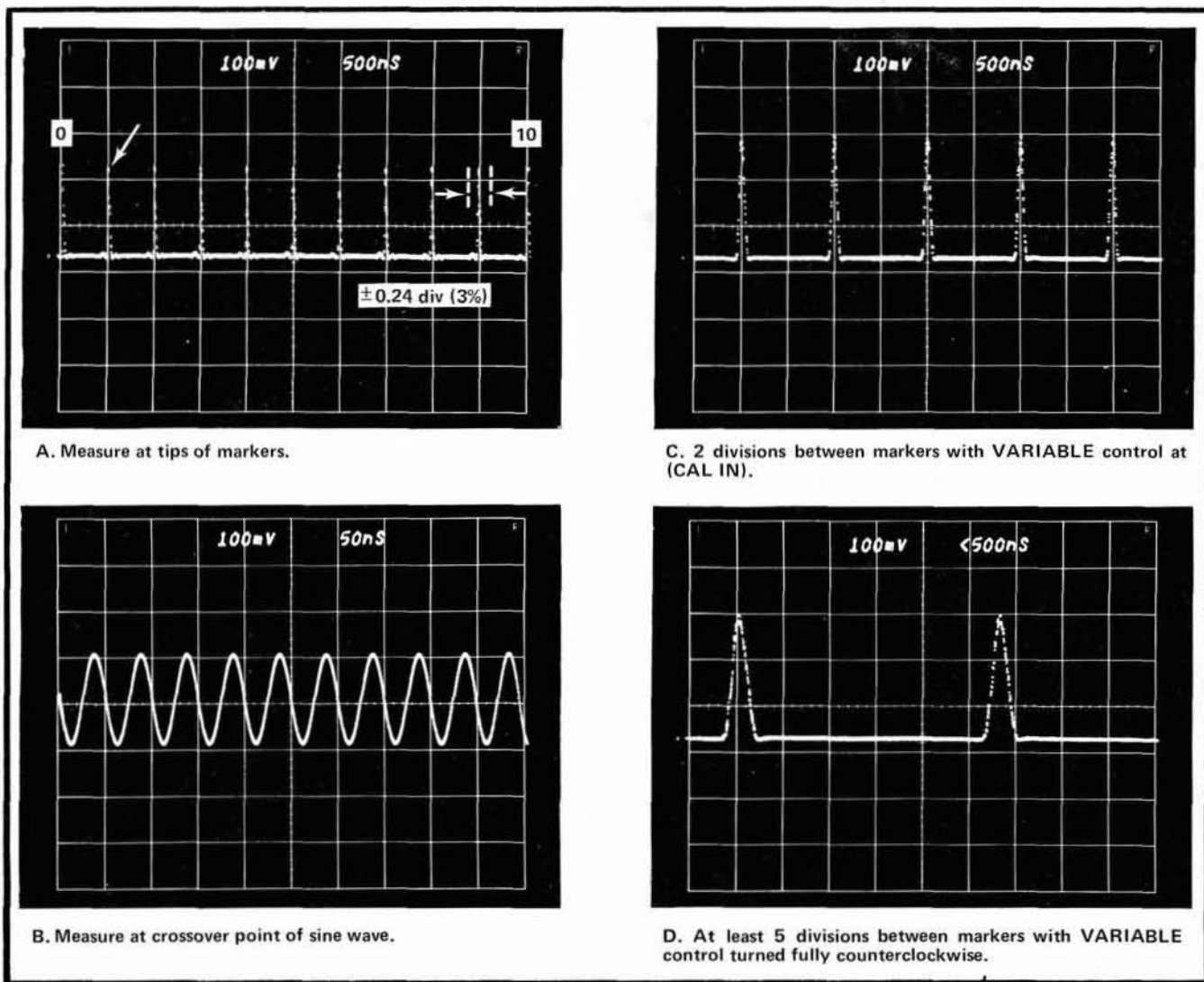

Fig. 5-4. Typical displays for checking timing accuracy.

h. Push the VARIABLE control to the (CAL IN) position.

4. Check Time Position Range

a. Set the SWEEP RANGE switch to 50 ns and the TIME/DIV switch to 2 ns.

b. Set the Time Mark Generator to 10 ns.

c. Set the TIME POSITION and FINE controls fully clockwise and use a crossover point on the cycle near the left graticule edge as a reference position.

d. Turn the TIME POSITION controls slowly counterclockwise and count the number of cycles (or markers) that pass through the reference position; see Fig. 5-5. Ranges

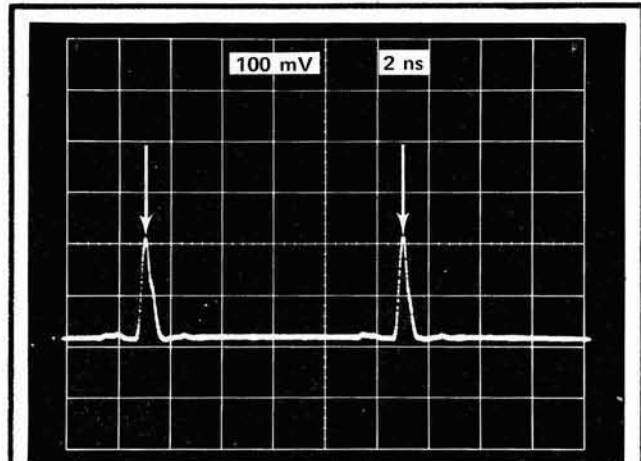

A. Reference positions.

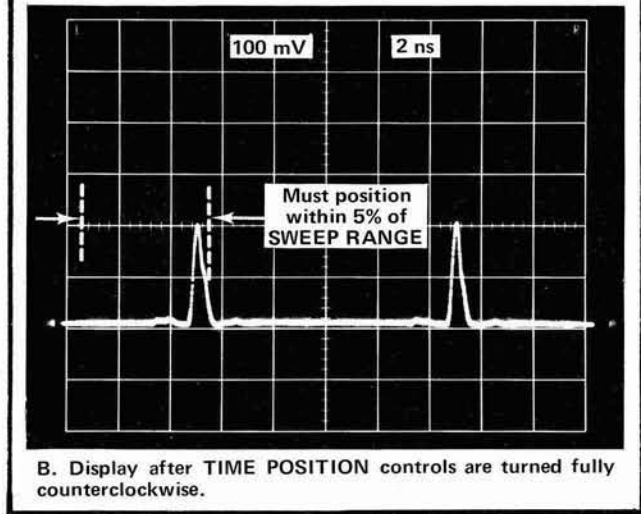

B. Display after TIME POSITION controls are turned fully counterclockwise.

Fig. 5-5. Time Position control range check.

should be within 5% of the SWEEP RANGE. Turn the FINE control fully clockwise and note the movement. FINE range should be at least 0.9% of the SWEEP RANGE.

e. Check the TIME POSITION positioning range as listed in Table 5-2 on each SWEEP RANGE switch setting.

TABLE 5-2
TIME POSITION Range Checks

SWEEP RANGE	TIME/DIV	Input signal	Marker or markers to move through reference position	Tolerances	
				5%	0.9%
50 ns	2 ns	10 ns	5 cycles	2.5 ns	45 ns
.5 μ s	10 ns	50 ns	10 cycles	25 ns	4.5 ns
5 μ s	.1 μ s	0.5 μ s	10 markers	.25 μ s	45 ns
50 μ s	1 μ s	5 μ s	10 markers	2.5 μ s	.45 μ s
.5 ms	10 μ s	50 μ s	10 markers	25 μ s	4.5 μ s
5 ms	.1 ms	.5 ms	10 markers	.25 ms	45 μ s
50 ms	1 ms	5 ms	10 markers	2.5 ms	.45 μ s

f. Disconnect the Time Mark Generator signal cables.

5. Adjust Timing (R260, R265 and C292)



PERFORMANCE CHECK ONLY

Steps 5 through 12 are not applicable to a performance check. Set controls as given preceding step 13 and proceed with step 13.

a. Set the SWEEP RANGE switch to 50 ms and the TIME/DIV switch to 5 ms. Apply 5 ms time markers from the Time Mark Generator as in the preceding step.

b. Set the TIME POSITION controls clockwise to align the markers to the graticule.

c. Adjust the Slow Timing control R265, on the Timing Board (Fig. 5-6B) for exactly one marker per division.

d. Set the SWEEP RANGE switch to .5 ms and apply 50 μ s markers.

e. Adjust the Fast Timing control R260, on the Timing Board, for exactly one marker per division.

Performance Check/Calibration—7T11

f. Set the SWEEP RANGE switch to 50 ns and apply the 5 ns sine wave from the Time Mark Generator.

b. Set the Time Mark Generator for 5 ms markers.

g. Adjust the 50 ns Timing control C292, on the timing Board, for one cycle per division.

c. Remove Q668 on the Analog Logic Board (Fig. 5-6A)) and check that the beginning of the trace is no longer blanked (the trace is visible to the left of the graticule).

6. Adjust R500, R550, R310, C313, R588, C237, R440 and R645

a. Set the SWEEP RANGE switch to 50 ms.

d. Replace Q668.

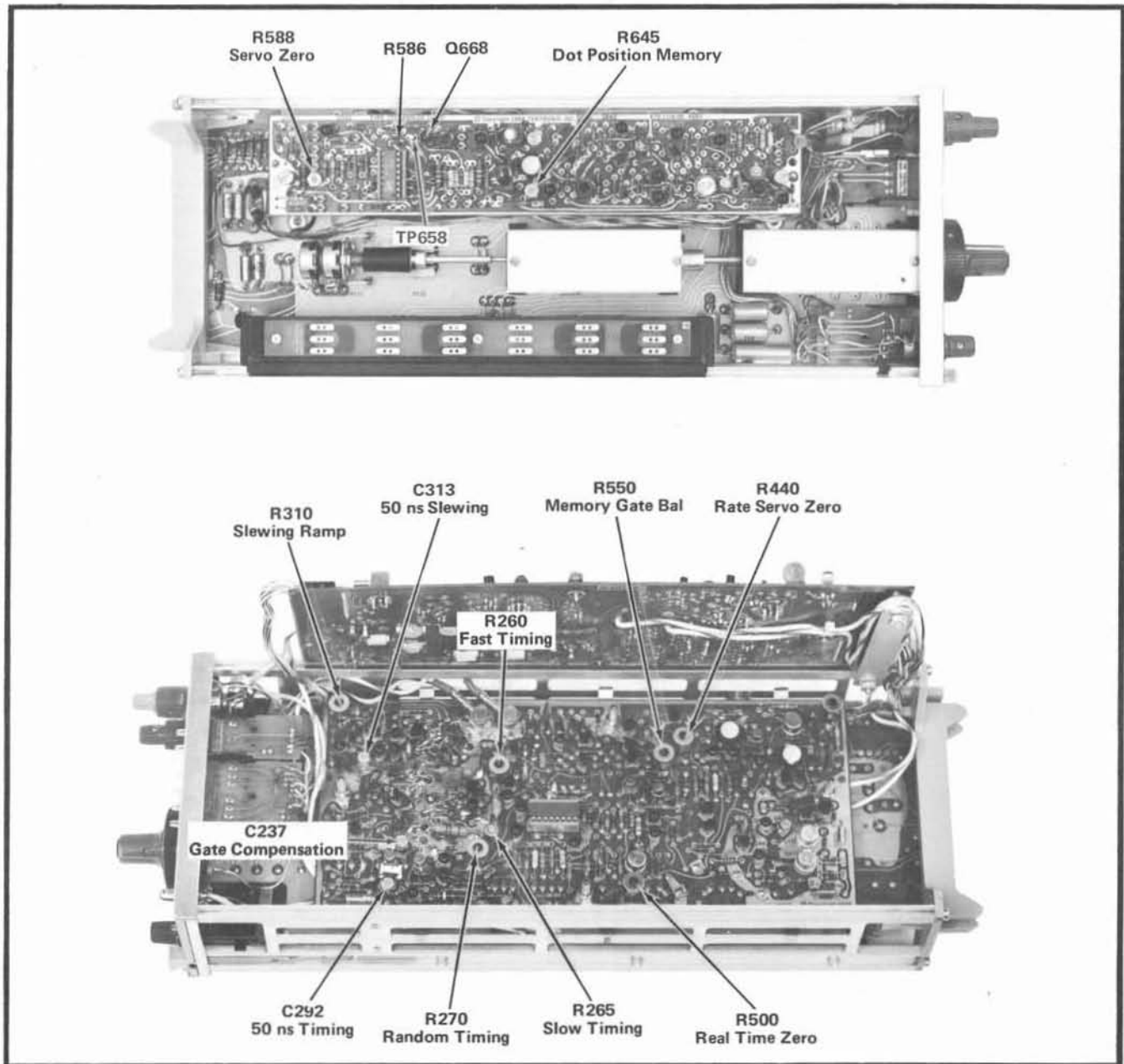

Fig. 5-6. Test point and adjustment location, steps 5, 6 and 7.

e. Set the POSITION control (front-panel) so the trace starts at the left edge of the graticule.

f. Adjust the Real Time Zero control R500, on the Timing Board (Fig. 5-6B) so the time mark starts at the left edge of the graticule.

g. Set the TIME/DIV switch at 50 μ s and readjust R500 to place the marker in the first graticule division.

h. Rotate the TIME/DIV switch and check that the marker or leading edge of the marker is within the graticule area (at 10 μ s, the leading edge may be off the graticule area and false dots will be present).

i. Set the TIME/DIV switch to 5 ms.

j. Adjust Memory Gate Bal control R550 on the Timing Board to reset the marker at the left edge of the graticule.

k. Turn off the Oscilloscope power and use a small screwdriver to pry up the plug-in end of R586, on the Analog Logic Board. Remove transistor Q668. Set the TIME POSITION control fully CW and turn the Oscilloscope power on.

l. Check for approximately 10.2 divisions of trace length. Use the Servo Zero adjustment (R588) to position the trace if it is not centered.

The following adjustments should correct for movement and trace alignment.

m. Remove the signal cable at the 7S11 Sampling Head input.

n. Set the SWEEP RANGE switch at 50 μ s, the SCAN control between its fully CCW and midposition, and the TIME POSITION control fully CW.

o. Adjust Slewing Ramp control (R310) for a trace length of 10.2 divisions.

p. Set the SWEEP RANGE switch to 50 ns.

q. Adjust the 50 ns Slewing control C313 (use an insulated tool) for a trace length of 10.2 divisions.

r. Set the SWEEP RANGE switch to 50 μ s and the TIME/DIV switch to 2 μ s. Check that the trace is centered on the graticule.

s. Adjust Servo Zero control R588 (on the Analog Logic Board) to align the trace to the graticule within a half a division, at TIME/DIV switch settings of 5 μ s, 2 μ s, and 1 μ s. Use a compromise setting of R588 that results in the least movement of the display when switching between the TIME/DIV settings above.

t. Set the SWEEP RANGE switch to 50 ns and the TIME/DIV switch to .2 ns.

u. Adjust Gate Compensation control C237, on the Timing Board, to align the trace to the graticule.

v. Turn the TIME/DIV switch to the 5 ns position and check that the trace remains on the graticule.

w. Set the SWEEP RANGE switch to 50 μ s and the TIME/DIV switch to 2 μ s. Push in the RANDOM switch. Set the Time Mark Generator to 5 μ s markers.

x. Adjust the Rate Servo Zero control R440, located on the Timing Board to align the trace to the graticule.

y. Turn off the Oscilloscope power and connect R586. Turn the Oscilloscope power on.

z. Push in the SEQUENTIAL switch and check that the trace is aligned with the graticule on all settings of the TIME/DIV switch (lines up to either graticule edge).

aa. Adjust Dot Position Memory control R645, located on the Analog Logic Board to align the trace.

ab. Check all positions of the SWEEP RANGE switch and TIME/DIV switch for correct alignment and no trace or dot movement.

NOTE

An aid when making the adjustments following step 6-n is to observe the output of the Dot Position Memory (TP658). Use a plug-in such as the 7A13. The AC and DC voltages present at this test point should be kept as small as possible. An AC signal at this point will show up on the display as a nonlinear dot distribution.

7. Adjust Random Timing (R270) ❶

a. Push in the RANDOM switch, turn the SCAN control fully counterclockwise, set the SWEEP RANGE switch to $.5 \mu\text{s}$ and the TIME/DIV switch to 1 ns.

b. Apply a 10 ns sine wave to the 7S11 Sampling Head Input connector and the 7T11 TRIG INPUT.

c. Obtain a stable display with the TRIG LEVEL control and observe the display for a momentary pulling or tugging to the left (usually less than a division) which has a slow repetitive cycle (about a second).

d. Adjust the Random Timing control R270, on the Timing Board to eliminate the pulling in the display.

e. Disconnect the Time Mark Generator signal cables.

f. Turn off the Oscilloscope power, remove the Trigger Board from the chassis channel and tighten the locking screws. Install the TRIG INPUT connector in the front panel and tighten the 5/16-inch nut. Turn on the Oscilloscope power.

8. Adjust Trig Level ❶

a. Set the Oscilloscope Vertical Mode switch to Left and the Horizontal Mode switch to B.

b. Set the 7A13 Volts/Div switch to .1 V, +Input to DC, and -Input to Vc.

c. Connect the 1X probe from the +Input to the junction of R68-R69, on the Trigger Board (Fig. 5-7).

d. Set the 7A13 Fine Comparison Voltage to about +6 volts to position the trace at the graticule center.

e. Push in the +SLOPE, then the -SLOPE switches. Set the TRIG LEVEL control for no trace movement with changes in SLOPE.

The TRIG LEVEL control should be pointing at 12 o'clock (dot straight up). If slightly off, loosen the allen nut, position the knob so the dot is straight up, and tighten the allen nut. If the control is considerably off, Q62 and Q72 do not pull equal currents and one or both must be changed.

f. Set the Oscilloscope Vertical Mode switch to Right and the Horizontal Mode switch to A. Remove the probe.

9. Adjust Stability (R135) and Trig Level Zero (R120) ❶

a. Set the SWEEP RANGE switch to $50 \mu\text{s}$, the TIME/DIV switch to $5 \mu\text{s}$ and push in the SEQUENTIAL switch. Do not move the TRIG LEVEL control from the 12 o'clock setting.

b. Turn the STABILITY control fully counterclockwise and check that the trace is off. Turn the STABILITY control slowly clockwise.

c. Adjust Stab Zero control R135 and Trig Level Zero control R120 so the trace starts to oscillate when the STABILITY control is about 60° to 90° from fully counterclockwise. See Fig. 5-7 for control locations.

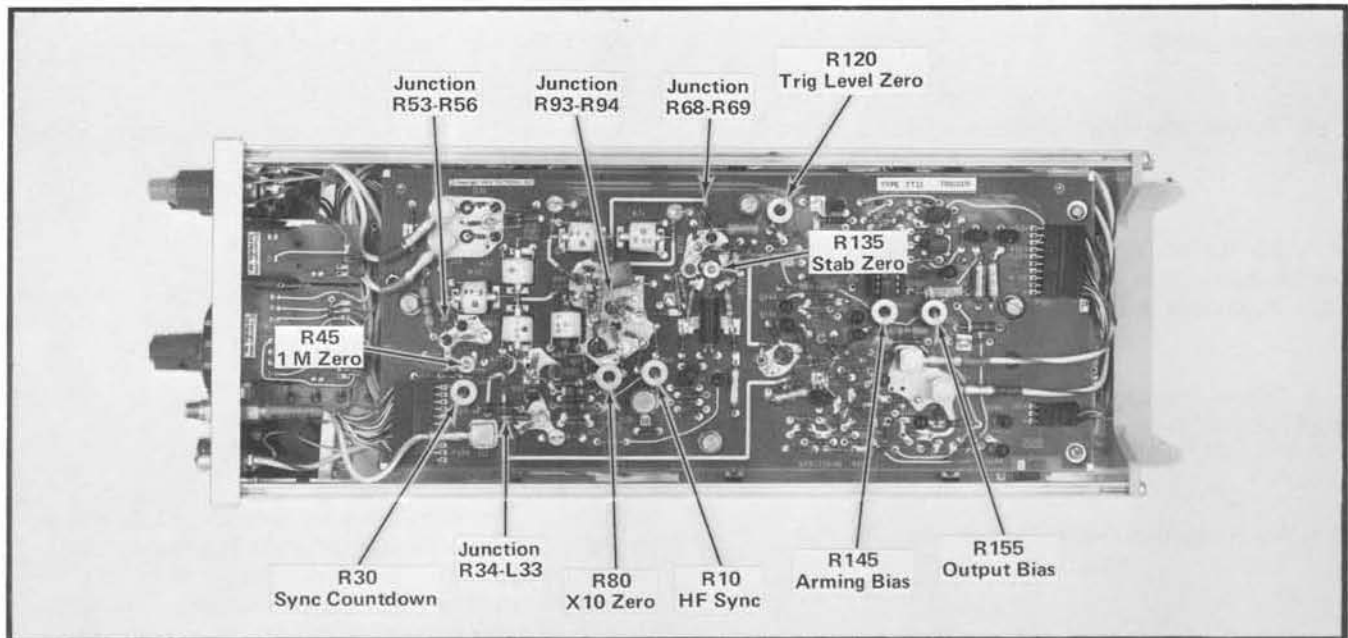

Fig. 5-7. Test point and adjustment locations on the Trigger Board, 7T11 right side.

10. Adjust External Trigger Zero (R80 and R45) ①

- a. Connect a BNC $50\ \Omega$ termination and BNC to 3 mm adapter to the TRIG INPUT connector.
- b. Push in the EXT $50\ \Omega$ 2 V MAX switch and the TRIG AMP X10 switch.
- c. Set the Oscilloscope Vertical Mode switch to Left and the Horizontal Mode switch to B.
- d. Set the 7A13 -Input to GND, the BW switch to 5 MHz, and the Volts/Div switch to 2 mV.
- e. Connect the 1X probe to the junction of R94-R93; see Fig. 5-7.
- f. Adjust X10 Zero control R80 for zero volts.
- g. Push in the EXT $1\ \text{M}\Omega$ switch. Connect the 1X probe to the junction of R53-R56.
- h. Adjust 1 M Zero control R45 for zero volts within 2 mV.
- i. Disconnect the probe.

11. Adjust HF Sync (R10 and R30) ①

- a. Push in the EXT HF SYNC switch. Set the TRIG LEVEL and STABILITY controls fully counterclockwise.
- b. Set the 7A13 Volts/Div switch to 20 mV, the BW switch to Full, and the 7B50 Time/Div switch to $.05\ \mu\text{s}$.
- c. Disconnect the 1X probe and connect the 10X probe to the 7A13 +Input.
- d. Connect the 10X probe to the junction of R34-L33.
- e. Obtain a stable display and check for a pulse repetition rate of about 10 MHz (between 5 MHz and 15 MHz is acceptable). See Fig. 5-8.
- f. Adjust the Sync Countdown control R30 for a 10 MHz repetition rate.

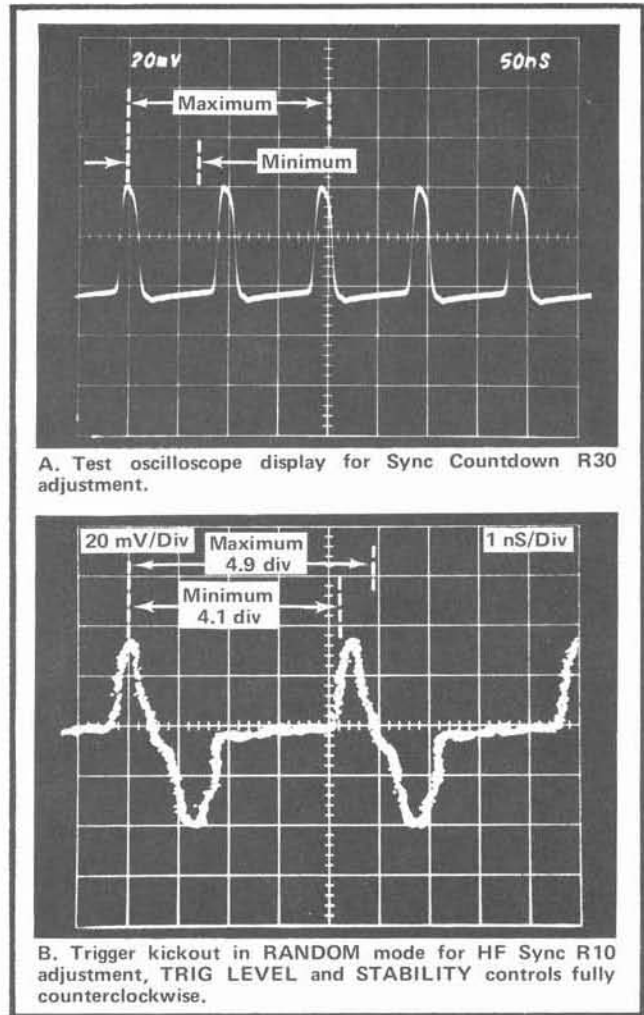

Fig. 5-8. Typical displays for HF Sync adjustments.

- g. Remove the probe. Set the Oscilloscope Vertical Mode switch to Right and the Horizontal Mode switch to A.
- h. Set the SWEEP RANGE switch to 50 ns and the TIME/DIV switch to 1 ns. Turn the SCAN control fully counterclockwise.
- i. Connect the 7T11 TRIG INPUT to a 3 mm to BNC adapter, 5X BNC attenuator, $50\ \Omega$ BNC coaxial cable and BNC to GR874 adapter to the Sampling Head Input connector. Set the 7S11 mVolts/Div switch to 10.
- j. Push in the RANDOM switch and observe the display as the TRIG LEVEL and STABILITY controls are both turned fully clockwise and fully counterclockwise.
- k. Check that the period between kickout pulses (see Fig. 5-8B) at the fully counterclockwise settings is between

Performance Check/Calibration—7T11

4.9 ns and 4.1 ns (frequency between 205 MHz and 245 MHz). Turn both controls fully clockwise and check for a period 80% (or less) of the period at the fully counterclockwise setting (frequency increase by 25%).

l. Adjust HF Sync control R10 for correct operation as described in k.

m. Push in the SEQUENTIAL switch. Turn the TIME POSITION control fully clockwise. No kickout should be seen at any position of the TRIG LEVEL and STABILITY controls. If kickout is present, check Q22, Q26 and Q32.

n. Disconnect the coaxial cable and adapter.

12. Adjust Output Bias (R155) and Arming Bias (R145) ①

a. Set the 7S11 Units/Div switch to 50.

b. Connect the Time Mark Generator Marker Output to a 5X BNC attenuator and a BNC T connector. To the T, connect two 50 Ω coaxial cables; one to a BNC to GR874 adapter to the Sampling Head Input, and the other to a BNC to 3 mm adapter to the 7T11 TRIG INPUT connector. Set the Marker Selector at 10 ns sine wave.

c. Set the TIME/DIV switch at 1 ns. Push in the SEQUENTIAL switch, +SLOPE switch and the EXT 50 Ω 2

V MAX switch. Set the TRIG LEVEL control at 12 o'clock and the STABILITY control fully counterclockwise.

d. Initially set both Output Bias control R155 and Arming Bias control R145 (see Fig. 5-7) fully clockwise. The trace actually free-runs.

e. Set Arming Bias control R145 90° counterclockwise.

f. Turn Output Bias control R155 counterclockwise slowly; observe a sudden 3-5 ns jump in the sine wave. Note the position of the control, and continue turning it counterclockwise until the trace stops. Again, note the control position. Set Output Bias control R155 midrange between the two noted settings.

g. Disconnect the Time Mark Generator signal connections.

h. Turn off the Oscilloscope power. Remove both 7T11 and 7S11 instruments and the extender. Remove the RF cable assembly and reconnect the Sampling Drive connector in the 7S11, and the cable to J344 in the 7T11. Replace the side panels. Install both units in the Oscilloscope and turn the power on.



Avoid exceeding the input limitations specified for your sampling head or the 7T11 TRIG INPUT. Set your oscilloscope or signal generator output to minimum before connecting to its output.

NOTES

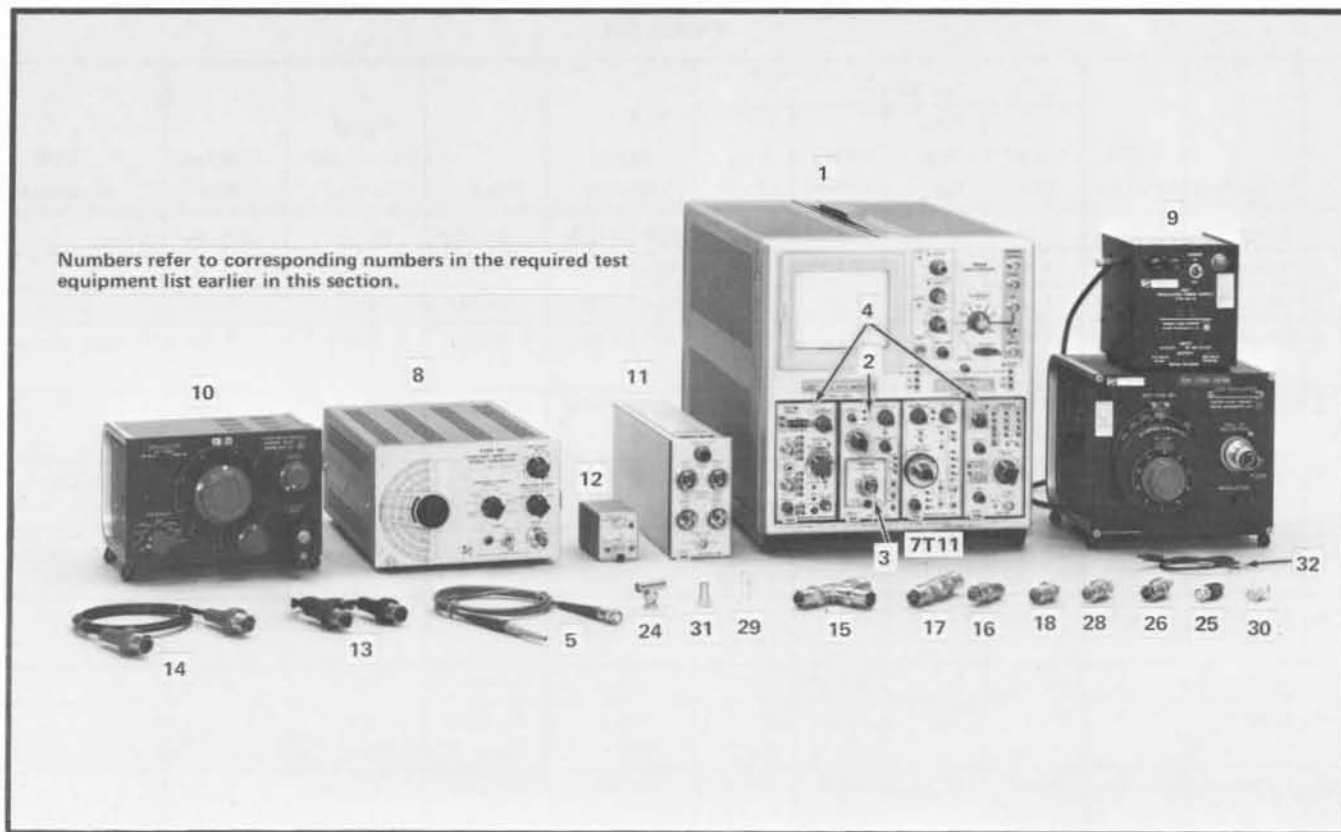

Fig. 5-9. Test equipment required for steps 13 through 23.

13. Check Triggering Capability

Equipment required is shown in Fig. 5-9.

Set the equipment controls as follows:

	7504
Vertical Mode	RIGHT
Horizontal Mode	A
	7S11
mVOLTS/DIV	20
Polarity	+ up
Normal/Smooth	NORMAL
	7T11
Slope	+
Time Position	Midposition
Trig Amp	X1
Trigger Mode	INT
Time Pos Rng	5 ms
Time/Div	.1 ms

GR-1310A

Frequency	5 kHz
Level (output)	fully CCW

Connect the output of the GR1310A Oscillator through a General Radio Type 2740 BJ Adapter and a 50 Ω coaxial cable to the input of the Type S-1 Sampling Head. During the following checks, adjust the 7T11 Stability and Trig Level controls to check for stable triggering. On Real Time ranges the Time Position control also aids in stabilizing triggering.

Use Table 5-3 to check that the triggering requirements of the 7T11 are met. This table shows the required control settings, the signal source, and signal frequency and amplitude. The signal generator output amplitude is correct when its signal causes the amount of vertical deflection shown under the display size column.

Notes 1, 2, 3, and 4, below Table 5-3, give special instructions that apply to indicated checks in the table. Changes in control settings between successive steps are indicated in the table with an asterisk.

TABLE 5-3

	Triggering	7S11 mV/div	7T11				Signal Source	Freq.	Signal Generator Output	Display Size	10X Attenuator
			Time/ Div	Time Pos Rng	TRIG AMP	Trig Mode					
1	Internal	20	.1 ms	5 ms	X1	INT	GR1310A	5 kHz	50 mV	2.5 div	None
2	Internal	5*	.1 ms	5 ms	X10*	INT	GR1310A	5 kHz	5 mV	1 div	
3	Internal	200*	.1 ms	5 ms	X10	INT	GR1310A	5 kHz	1 V	5 div	
4	External ¹	5*	.5 ms*	5 ms	X10	EXT* 50 Ω	GR1310A	1 kHz	5 mV	1 div	Trigger signal
5	External	5	.5 ms	5 ms	X10	EXT* 1 MΩ	GR1310A	1 kHz	5 mV	1 div	
6	External ²	100*	.5 ms	5 ms	X10	EXT 1 MΩ	GR1310A	1 kHz	2 V	2 div	S-1 input
7	External ³	20*	5 ms*	50 ms*	X1*	EXT 1 MΩ	GR1310A	50 Hz	50 mV	2.5 div	Trigger signal
8	External	20	5 ms	50 ms	X1	EXT* 50 Ω	GR1310A	50 Hz	50 mV	2.5 div	
9	Internal ⁴	5*	10 ns*	.5 μs*	X10*	INT*	191*	50 MHz*	5 mV	1 div	
10	External	5	10 ns	5 μs	X10	EXT* 50 Ω	191	50 MHz	5 mV	1 div	
11	External	5	10 ns	.5 μs	X10	EXT* 1 MΩ	191	50 MHz	5 mV	1 div	
12	External	50*	10 ns	5 μs	X1*	EXT 1 MΩ	191	100 MHz*	50 mV	1 div	
13	Internal ⁵	50	1 ns*	50 ns*	X1	INT*	GR1361A*	500 MHz*	50 mV	1 div	
14	External	50	1 ns	50 ns	X1	EXT* 50 Ω	GR1361A	1 GHz*	50 mV	1 div	
15	External HF SYNC	50	1 ns	50 ns	X1	HF* SYNC	GR1361A	1 GHz	100 mV	2 div	
16	External HF SYNC	200*	1 ns	50 ns	X1	HF SYNC	GR1361A	1 GHz	1 V	5 div	Replace 10X with 2X

¹ Disconnect the coaxial cable from the oscillator at the input to the Type S-1 Sampling Head. Connect a "T" connector having GR connectors to the Type S-1 and reconnect the coaxial cable from the oscillator to one of the "T" connectors. Connect the other connector of the "T" through a 10X attenuator and a 50 Ω coaxial cable with GR connectors to the TRIG INPUT connector of the 7T11.

² Remove the 10X attenuator from the trigger path and replace the attenuator between the "T" connector and the sampling head input.

³ Turn the Level control of the GR1310A Oscillator fully CCW. Remove the 10X attenuator from its position between the "T" and the sampling head input and reinstall it in the trigger path between the "T" and the coaxial cable to the TRIG INPUT connector.

⁴ Replace the GR1310A Oscillator with a Tektronix Type 191 Constant Amplitude Signal Generator.

⁵ Replace the Tektronix Type 191 Constant Amplitude Signal Generator with a General Radio GR1361A Oscillator.

Optional Check. Check HF SYNC triggering at 12.4 GHz with a 200 mV and 500 mV triggering signal. Use a signal source, such as the Hewlett-Packard HP626A or a suitable avalanche diode cavity oscillator, that will provide the required signal frequency and voltage.

14. Check Display Jitter

Connect one end of a 50 Ω power divider having GR connectors (Tektronix Part No. 017-0082-00) into INPUT 1 of a 7M11 Delay Line. Connect OUTPUT 1 of the 7M11 to the input of the Type S-1 Sampling Head. Connect the

output of a Type S-50 Pulse Generator Head through a short length of 50 Ω coaxial cable to the power divider. Connect the other power divider connector through a 50 Ω coaxial cable to the TRIG INPUT connector of the 7T11.

Set the equipment controls as described below:

7S11

mVOLTS/DIV 50
Normal/Smooth Normal

7T11

TIME POS RNG 50 ns
TIME/DIV 2 ns/Div
SCAN REP
SCAN control midposition
TIME POSITION fully CW
STABILITY CCW
Trigger Mode EXT 50 Ω
Random/Sequential Sequential

7M11

Trigger Selector OFF

a. Adjust the 7T11 Trigger Level control, if necessary, for a display such as is shown in Fig. 5-10A.

b. Rotate the TIME/DIV control clockwise to .2 ns, a step at a time, while using the TIME POSITION, STABILITY, and TRIG LEVEL controls to maintain the most stable display of the pulse leading edge.

c. Set the 7S11 to a 2 mV/Div position and use the DC Offset and TIME POSITION controls to keep the pulse leading edge visible.

d. While maintaining as stable a display as possible, rotate the TIME/DIV control to the 10 ps/Div position and check for less than 10 ps of jitter as shown in Fig. 5-10B.

NOTE

If display jitter exceeds the specified 10 ps value, the cause is excessive trigger jitter or jitter caused by other circuits of the sampling system. The procedure of step 15 removes the trigger jitter portion of display, and is therefore a troubleshooting aid.

To check the display jitter using the EXT 1 MΩ triggering mode, push in the 1 MΩ pushbutton and repeat the

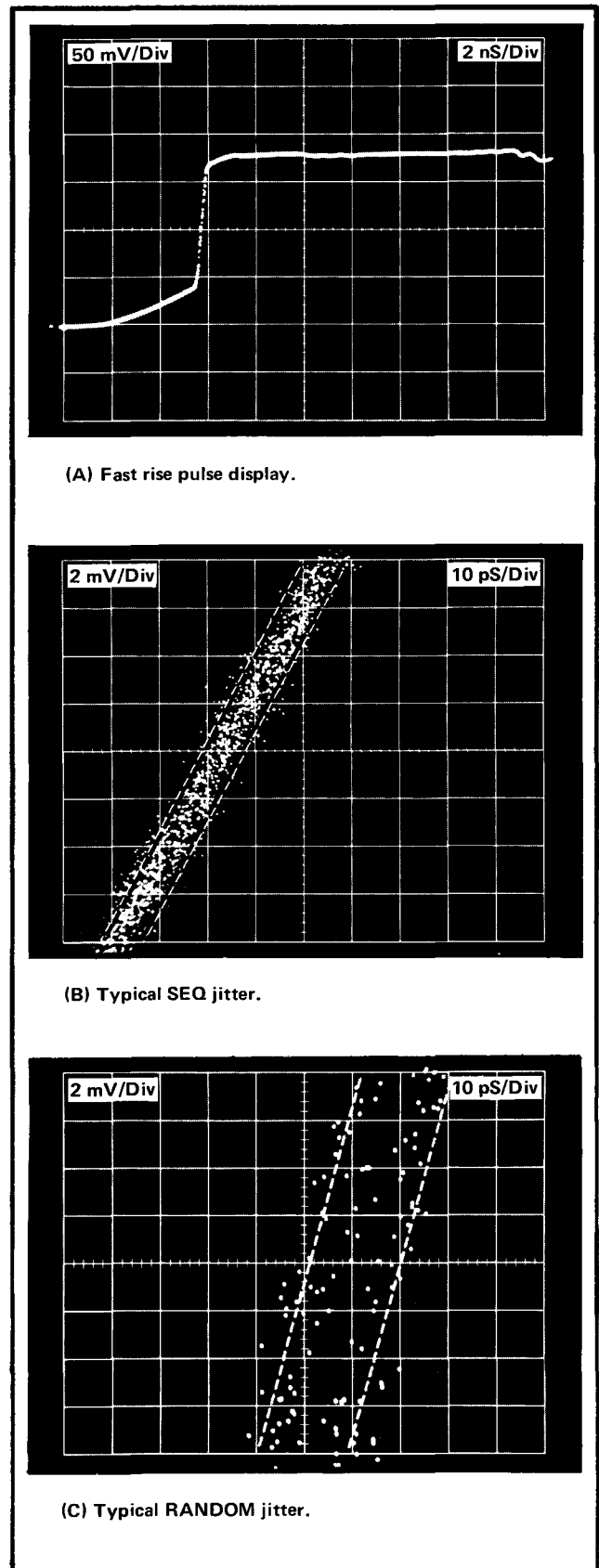

Fig. 5-10. Determining display jitter.

Performance Check/Calibration—7T11

procedure given above for the 50 Ω triggering mode. Display jitter must not exceed 10 ps.

Check display jitter using Random mode of operation.

- a. Remove the coaxial cable between the 7M11 OUTPUT 1 and the sampling head input.
- b. Remove the power divider from the 7M11 INPUT 1 and insert the power divider into the sampling head input connector.
- c. Push in the RANDOM and MAN SCAN pushbuttons.
- d. Obtain a stable display of the pulse leading edge using the method given above, and check that display jitter is 30 ps or less. A typical display is shown in Fig. 5-10C.
- e. Return SCAN to REP operation.

Check display jitter under the conditions shown in Table 5-4.

Use a Tektronix Type 191 Signal Generator or an equivalent instrument that provides suitable output frequency and voltage. Carefully adjust the 7T11 Stability and Trig Level controls for minimum jitter before measuring the jitter. Use REP SCAN for sequential mode operation and MAN SCAN for the Random mode checks.

TABLE 5-4

Display Jitter with Optimum Trigger Conditions

Mode	TIME POS RNG	TIME/DIV	Jitter
SEQ	500 ns	.1 ns	≤0.4 division
	5 μs	1 ns	
	50 μs	10 ns	
RANDOM	500 ns	.1 ns	≤1 division
	5 μs	1 ns	
	50 μs	10 ns	
REAL TIME	.5 ms	.1 μs	≤0.4 division
	5 ms	1 μs	
	50 ms	10 μs	

(Optional) Check display jitter using HF SYNC triggering.

Check for 20 ps or less of jitter at 12.4 GHz with a 200 mV triggering signal applied to the TRIG INPUT connector. A

Hewlett-Packard HP626A or other signal source producing the required frequency and voltage is used for this check.

15. Check Display Jitter Not Due to Triggering

This step may be omitted provided the requirements of step 14 are met. This procedure removes jitter due to the triggering circuits from the display. This step can therefore be considered as a troubleshooting aid in determining whether excessive jitter measured in step 14 is due to the triggering or to other circuits.

- a. Use initial equipment settings given for step 14.
- b. Obtain a free-running trace by turning the 7T11 STABILITY control fully cw and the TRIG LEVEL control to its approximate mid-position.
- c. Connect the 7T11 PULSE OUT connector through a 50 Ω coaxial cable (Tektronix Part No. 012-0127-00) and a GR to BNC adapter (Tektronix Part No. 017-0063-00) to INPUT 1 of the 7M11 DELAY LINE.
- d. Connect OUTPUT 1 of the 7M11 to the input of the Type S-1 sampling head.
- e. Use the TIME POSITION controls to keep the pulse leading edge displayed, and rotate the TIME/DIV control to its 10 ps position.

The displayed jitter remaining is due to circuits other than those used for triggering.

Control settings for step 16;

7S11 Sampling Unit

+UP	Pushed in
DC Offset	Centered display
mVolts/Div	100
Dot Response	Midrange
Normal	Pushed in

7T11 Sampling Sweep Unit

TIME POSITION	Fully clockwise
SLOPE	+
TRIG LEVEL	Midrange
STABILITY	Fully counterclockwise
RANDOM	Pushed in
TRIG AMP	X1
SWEEP RANGE	5 μs
TIME/DIV	20 ns

INT
SCAN

Pushed in
REP

16. Check Pulse Out into 50 Ω

a. Connect the 7T11 PULSE OUT connector to a BSM to BNC adapter, BNC coaxial cable, and BNC to GR874 adapter to the Sampling Head Input connector.

b. Turn the TIME POSITION control counterclockwise to display the rising portion of the pulse.

c. Check that the amplitude is at least 400 mV (see Fig. 5-11A).

d. Set the TIME/DIV switch to 2 ns. Set the 7S11 Variable control for 5 divisions amplitude at the rising portion. Measure risetime from the 10% to 90% amplitudes (center 4 divisions).

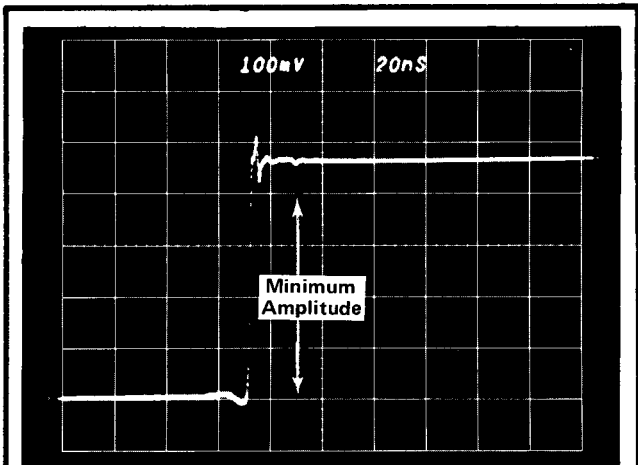

A. Amplitude check.

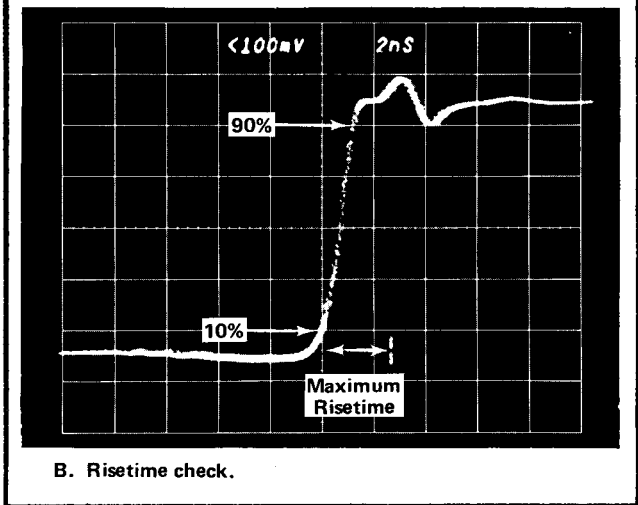

B. Risetime check.

Fig. 5-11. Typical display of the Pulse Out waveform.

e. Check that the risetime is 2.5 ns or less; see Fig. 5-11B.

f. Disconnect the signal cable. Push in the 7S11 Variable control.

17. Check Trigger Kickout

a. Connect the 7T11 TRIG INPUT connector to a 3 mm to GR874 adapter, and GR874 coaxial cable to the Sampling Head Input connector.

b. Turn the TIME POSITION controls fully clockwise and set the TIME/DIV switch to .5 μs.

c. Set the 7S11 mVolts/Div switch to 2, push in the Smooth switch and position the trace at the graticule center with the DC Offset control. Measure the amplitude of the kickout pulse.

d. Check that the trigger kickout pulse is within 2 mV or less (see Fig. 5-12).

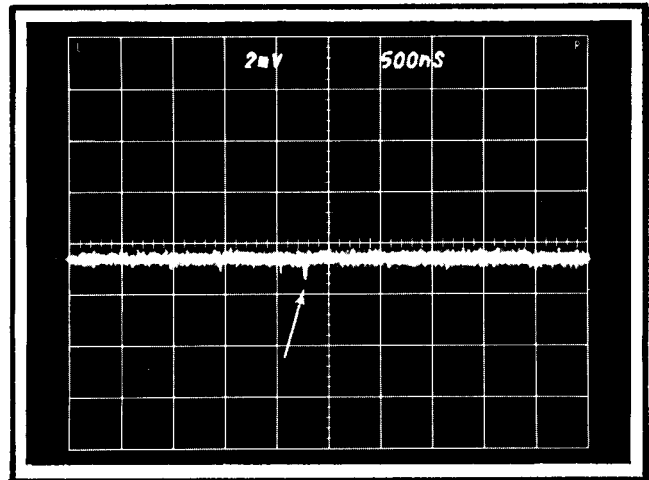

Fig. 5-12. Typical display of trigger kickout.

e. Remove the coaxial cable. Push in the 7S11 Normal switch.

Control settings of test oscilloscope for step 18;

7A13 Differential Comparator

+Input	DC
Volts/Div	.2 V
-Input	GND
BW	Full

7B50 Time Base

Level/Slope	For display
Mode	Auto
Coupling	AC
Source	Int
Magnifier	X1
Time/Div	10 μ s

18. Check Trigger Holdoff

a. Set the Oscilloscope Vertical Mode switch to Left and the Horizontal Mode switch to B.

b. Connect the 7T11 PULSE OUT connector to a BSM to BNC adapter, a BNC coaxial cable and BNC 50 Ω termination to the 7A13 +Input connector.

c. Check the display for trigger holdoff times as given in Table 5-5. Holdoff is the time between the leading positive-going portions of adjacent trigger pulses. See Fig. 5-13. Reset the 7B50 Time/Div switch as required.

d. Disconnect the coaxial cable.

TABLE 5-5

SWEEP RANGE	Minimum Trigger Holdoff	7B50 Time/Div
50 ns .5 μ s 5 μ s	25 μ s	10 μ s
50 μ s	200 μ s	50 μ s
.5 ms 5 ms 50 ms	2 ms	.5 ms 2 ms

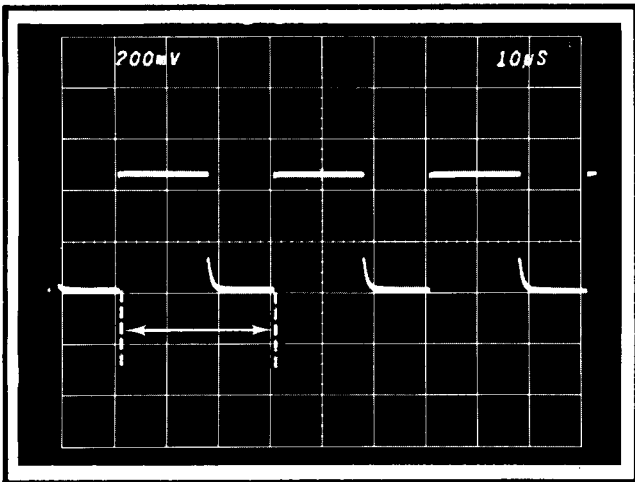

Fig. 5-13. Trigger holdoff measurement.

19. Check Strobe Kickback into Trigger

a. Set the Type 191 Constant Amplitude Signal Generator Amplitude switch at 35, Frequency Range switch at .35-.75 MHz, Amplitude Range switch at 5-50 mV and the Frequency control at .35 MHz.

b. Connect the Signal Generator Output to a GR874 to BNC adapter and BNC T connector. Connect one side of the T connector to a BNC to GR adapter and GR874 coaxial cable to the Sampling Head Input connector. Connect the other side of the T connector to a BNC coaxial cable and BNC to 3 mm adapter to the 7T11 TRIG INPUT connector.

c. Set the Oscilloscope Vertical Mode switch to Right and the Horizontal Mode switch to A.

d. Set the SWEEP RANGE switch to 5 μ s, the TIME/DIV switch to .5 μ s and the TIME POSITION controls fully clockwise. Push in the EXT 50 Ω 2 V MAX switch.

e. Set the 7S11 Units/Div switch to 5 mV, the 7T11 STABILITY control fully counterclockwise and obtain a stable display with the TRIG LEVEL control.

f. Set the Signal Generator Amplitude Variable control for a display amplitude of 5 divisions.

g. Check the vertical amplitude of the largest discontinuity for a maximum of 3 minor divisions (3 mV or less), the strobe kickback. See Fig. 5-14.

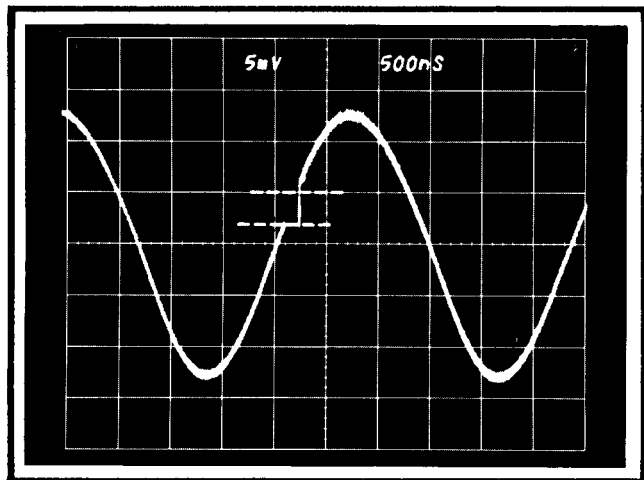

Fig. 5-14. Typical display of strobe kickback.

h. Disconnect the Signal Generator connections.

20. Check Minimum Trigger Rate in Random Mode

a. Connect the Time Mark Generator Trigger Out connector to a BNC coaxial cable and BNC to 3 mm adapter to the 7T11 TRIG INPUT connector. Set the Trigger Selector switch at 10 ms.

b. Set the SWEEP RANGE switch to 50 μ s, the TIME/DIV switch to 5 μ s and push in the EXT 50 Ω 2 V MAX switch.

c. Set the TRIG LEVEL control for a triggered sweep.

d. Check that the sweep length is at least 9 divisions.

21. Check Repetitive Scan Rate

a. Set the Oscilloscope Vertical Mode switch to Left and the Horizontal Mode switch to B.

b. Set the 7A13 Volts/Div switch to 5 and connect the 1X probe from the +Input connector to the 7T11 SWEEP OUT jack.

c. Set the 7B50 Time/Div switch to 5 ms and turn the SCAN control fully clockwise.

d. Check that the time per sweep (sawtooth) is 25 ms or less; see Fig. 5-15.

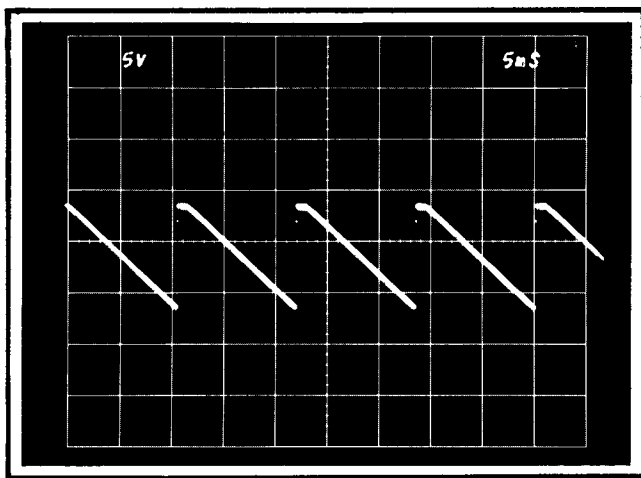

Fig. 5-15. Sweep Out waveform to check Repetitive Scan rate.

e. Set the 7B50 Time/Div switch to .1 s and turn the SCAN control fully counterclockwise.

f. Check that the time per sweep is 500 ms or more.

22. Check Sweep Out Range

a. Set the 7B50 Mode switch at P-P Auto. Set the 7A13 Volts/Div switch to 2 and push in the GND +Input switch. Position the trace at the center graticule line.

b. Set the 7A13 +Input switch to DC.

c. Push in the SCAN MAN switch and check that the trace (on the 7A13) is at +5 volts with the SCAN control fully counterclockwise.

d. Turn the SCAN control fully clockwise and check that the trace is at -5 volts.

23. Check External Input

a. Set the Oscilloscope Horizontal Mode switch to A.

b. Push in the SCAN MAN switch and check that the dot is at the right edge of the graticule.

c. Push in the SCAN EXT INPUT switch and connect the 7S11 Offset Out to the 7T11 EXT INPUT 1 V/DIV 100 k Ω jack through a patch cord (the Simpson meter lead).

d. Set the 7S11 DC Offset control to position the dot at the right edge of the graticule.

e. Turn the SCAN control fully counterclockwise and check that the dot moves to the left edge of the graticule.

f. Push in the SCAN REP switch and disconnect the patch cord.

This completes the Performance Check/Calibration procedure.

REPLACEABLE ELECTRICAL PARTS

PARTS ORDERING INFORMATION

Replacement parts are available from or through your local Tektronix, Inc. Field Office or representative.

Changes to Tektronix instruments are sometimes made to accommodate improved components as they become available, and to give you the benefit of the latest circuit improvements developed in our engineering department. It is therefore important, when ordering parts, to include the following information in your order: Part number, instrument type or number, serial number, and modification number if applicable.

If a part you have ordered has been replaced with a new or improved part, your local Tektronix, Inc. Field Office or representative will contact you concerning any change in part number.

Change information, if any, is located at the rear of this manual.

SPECIAL NOTES AND SYMBOLS

X000 Part first added at this serial number
00X Part removed after this serial number

ITEM NAME

In the Parts List, an Item Name is separated from the description by a colon (:). Because of space limitations, an Item Name may sometimes appear as incomplete. For further Item Name identification, the U.S. Federal Cataloging Handbook H6-1 can be utilized where possible.

ABBREVIATIONS

ACTR	ACTUATOR	PLSTC	PLASTIC
ASSY	ASSEMBLY	QTZ	QUARTZ
CAP	CAPACITOR	RECP	RECEPTACLE
CER	CERAMIC	RES	RESISTOR
CKT	CIRCUIT	RF	RADIO FREQUENCY
COMP	COMPOSITION	SEL	SELECTED
CONN	CONNECTOR	SEMICOND	SEMICONDUCTOR
ELCTLT	ELECTROLYTIC	SENS	SENSITIVE
ELEC	ELECTRICAL	VAR	VARIABLE
INCAND	INCANDESCENT	WW	WIREWOUND
LED	LIGHT EMITTING DIODE	XFMR	TRANSFORMER
NONWIR	NON WIREWOUND	XTAL	CRYSTAL

CROSS INDEX—MFR. CODE NUMBER TO MANUFACTURER

Mfr. Code	Manufacturer	Address	City, State, Zip
00853	SANGAMO ELECTRIC CO., S. CAROLINA DIV.	P O BOX 128	PICKENS, SC 29671
01121	ALLEN-BRADLEY COMPANY	1201 2ND STREET SOUTH	MILWAUKEE, WI 53204
01295	TEXAS INSTRUMENTS, INC., SEMICONDUCTOR GROUP	P O BOX 5012, 13500 N CENTRAL EXPRESSWAY	DALLAS, TX 75222
03508	GENERAL ELECTRIC COMPANY, SEMI-CONDUCTOR PRODUCTS DEPARTMENT	ELECTRONICS PARK	SYRACUSE, NY 13201
03911	CLAIREX ELECTRONICS, DIVISION OF CLAIREX CORPORATION	560 S THIRD AVENUE	MT. VERNON, NY 10050
04713	MOTOROLA, INC., SEMICONDUCTOR PROD. DIV.	5005 E MCDOWELL RD, PO BOX 20923	PHOENIX, AZ 85036
07263	FAIRCHILD SEMICONDUCTOR, A DIV. OF FAIRCHILD CAMERA AND INSTRUMENT CORP.	464 ELLIS STREET	MOUNTAIN VIEW, CA 90402
08806	GENERAL ELECTRIC CO., MINIATURE LAMP PRODUCTS DEPARTMENT	NELA PARK	CLEVELAND, OH 44112
11237	CTS KEENE, INC.	3230 RIVERSIDE AVE.	PASO ROBLES, CA 93446
12617	HAMLIN, INC.	GROVE & LAKE STS.	LAKE MILLS, WI 53551
14193	CAL-R, INC.	1601 OLYMPIC BLVD.	SANTA MONICA, CA 90404
14552	MICRO SEMICONDUCTOR CORP.	2830 E FAIRVIEW ST.	SANTA ANA, CA 92704
15238	ITT SEMICONDUCTORS, A DIVISION OF INTERNATIONAL TELEPHONE AND TELEGRAPH CORP.	P.O. BOX 168, 500 BROADWAY	LAWRENCE, MA 01841
17856	SILICONIX, INC.	2201 LAURELWOOD DRIVE	SANTA CLARA, CA 95054
22229	SOLITRON DEVICES, INC., SEMICONDUCTOR GROUP	8808 BALBOA AVENUE	SAN DIEGO OPERS, CA 92123
24546	CORNING GLASS WORKS, ELECTRONIC COMPONENTS DIVISION	550 HIGH STREET	BRADFORD, PA 16701
26805	OMNI SPECTRA INC., MICROWAVE CONNECTOR DIV.	140 FOURTH AVE	WALTHAM, MA 02154
32997	BOURNS, INC., TRIMPOT PRODUCTS DIV.	1200 COLUMBIA AVE.	RIVERSIDE, CA 92507
50434	HEWLETT-PACKARD COMPANY	640 PAGE MILL ROAD	PALO ALTO, CA 94304
51642	CENTRE ENGINEERING INC.	2820 E COLLEGE AVENUE	STATE COLLEGE, PA 16801
53399	GERMANIUM POWER DEVICES CORP.	SHAWSHEEN VILLAGE STATION P.O. BOX 65	AMDOVER, MA 01810
54208	ELECTRO CONTROLS INC.	MATTHEWS AVE.	CANTON, MS 39046
55210	GETTIG ENG. AND MFG. COMPANY	PO BOX 85, OFF ROUTE 45	SPRING MILLS, PA 16875
56289	SPRAGUE ELECTRIC CO.	87 MARSHALL ST.	NORTH ADAMS, MA 01247
59660	TUSONIX INC.	2155 N FORBES BLVD	TUCSON, AZ 85705
71590	CENTRALAB ELECTRONICS, DIV. OF GLOBE-UNION, INC.	P O BOX 858	FORT DODGE, IA 50501
72982	ERIE TECHNOLOGICAL PRODUCTS, INC.	644 W. 12TH ST.	ERIE, PA 16512
73138	BECKMAN INSTRUMENTS, INC., HELIPOT DIV.	2500 HARBOR BLVD.	FULLERTON, CA 92634
74868	BUNKER-RAMO CORP., THE AMPHENOL RF DIV.	33 E. FRANKLIN ST.	DANBURY, CT 06810
75042	TRW ELECTRONIC COMPONENTS, IRC FIXED RESISTORS, PHILADELPHIA DIVISION	401 N. BROAD ST.	PHILADELPHIA, PA 19108
76854	OAK INDUSTRIES, INC., SWITCH DIV.	S. MAIN ST.	CRYSTAL LAKE, IL 60014
80009	TEKTRONIX, INC.	P O BOX 500	BEAVERTON, OR 97077
83508	GRANT PULLEY AND HARDWARE CO.	HIGH ST.	WEST NYACK, NY 10994
84411	TRW ELECTRONIC COMPONENTS, TRW CAPACITORS	112 W. FIRST ST.	OGALLALA, NE 69153
91418	RADIO MATERIALS COMPANY, DIV. OF P.R. MALLORY AND COMPANY, INC.	4242 W BRYN MAWR	CHICAGO, IL 60646
91637	DALE ELECTRONICS, INC.	P. O. BOX 609	COLUMBUS, NE 68601
95348	GORDOS CORPORATION	250 GLENWOOD AVENUE	BLOOMFIELD, NJ 07003
98291	SEAELECTRO CORP.	225 HOYT	MAMARONECK, NY 10544

Ckt No.	Tektronix Part No.	Serial/Model No. Eff	Dscont	Name & Description	Mfr Code	Mfr Part Number
	670-1118-00	B010100	B029999	CKT BOARD ASSY:LOGIC	80009	670-1118-00
	670-1118-01	B030000	B059999	CKT BOARD ASSY:LOGIC	80009	670-1118-01
	670-1118-02	B060000	B069999	CKT BOARD ASSY:LOGIC	80009	670-1118-02
	670-1118-03	B070000	B079999	CKT BOARD ASSY:LOGIC	80009	670-1118-03
	670-1118-04	B080000	B099999	CKT BOARD ASSY:LOGIC	80009	670-1118-04
	670-1118-05	B100000	B119999	CKT BOARD ASSY:LOGIC	80009	670-1118-05
	670-1118-06	B120000	B201370	CKT BOARD ASSY:LOGIC	80009	670-1118-06
	670-1118-07	B201371	B222994	CKT BOARD ASSY:LOGIC	80009	670-1118-07
	670-1118-08	B222995		CKT BOARD ASSY:LOGIC	80009	670-1118-08
C592	283-0000-00	XB100000		CAP.,FXD,CER DI:0.001UF,+100-0%,500V	59660	831-519-Z5U-102P
C594	283-0000-00	B010100	B099999	CAP.,FXD,CER DI:0.001UF,+100-0%,500V	59660	831-519-Z5U-102P
C594	283-0238-00	B100000		CAP.,FXD,CER DI:0.01UF,10%,50V	72982	8121N075X7R0103K
C619	283-0000-00			CAP.,FXD,CER DI:0.001UF,+100-0%,500V	59660	831-519-Z5U-102P
C620	283-0028-00			CAP.,FXD,CER DI:0.0022UF,20%,50V	56289	19C606
C624	283-0094-00			CAP.,FXD,CER DI:27PF,10%,200V	59660	835-583-COG0270K
C625	283-0177-00			CAP.,FXD,CER DI:1UF,+80-20%,25V	56289	273C5
C628	283-0154-00			CAP.,FXD,CER DI:22PF,5%,50V	72982	8111B061COG220J
C630	283-0108-00			CAP.,FXD,CER DI:220PF,10%,200V	56289	272C13
C631	283-0187-00	B010100	B079999	CAP.,FXD,CER DI:0.047UF,10%,400V	72982	8131N401X5R0473K
C631	283-0198-00	B080000		CAP.,FXD,CER DI:0.22UF,20%,50V	72982	8121N083Z5U0224M
C636	283-0159-00			CAP.,FXD,CER DI:18PF,5%,50V	72982	8111B065COG0180J
C654	283-0026-00	B010100	B029999	CAP.,FXD,CER DI:0.2UF,+80-20%,25V	56289	274C3
C654	283-0164-00	B030000		CAP.,FXD,CER DI:2.2UF,20%,25V	72982	8141N037Z5U0225M
C674	283-0115-00	XB060000		CAP.,FXD,CER DI:47PF,5%,200V	59660	805-519-COG0470J
C675	283-0197-00	B010100	B059999	CAP.,FXD,CER DI:470PF,5%,100V	72982	8121N075COG0471J
C675	283-0197-00	B060000	B222994	CAP.,FXD,CER DI:470PF,5%,100V (NOMINAL VALUE, SELECTED)	72982	8121N075COG0471J

C675	283-0359-00	B222995		CAP.,FXD,CER DI:1000PF,10%,200V	72982	8131N203COG0102K
CR591	152-0141-02			SEMICONV DEVICE:SILICON,30V,150MA	01295	1N4152R
CR595	152-0141-02			SEMICONV DEVICE:SILICON,30V,150MA	01295	1N4152R
CR596	152-0141-02			SEMICONV DEVICE:SILICON,30V,150MA	01295	1N4152R
CR597	152-0141-02	B010100	B079999X	SEMICONV DEVICE:SILICON,30V,150MA	01295	1N4152R
CR621	152-0141-02			SEMICONV DEVICE:SILICON,30V,150MA	01295	1N4152R
CR622	152-0141-02			SEMICONV DEVICE:SILICON,30V,150MA	01295	1N4152R
CR627	152-0141-02			SEMICONV DEVICE:SILICON,30V,150MA	01295	1N4152R
CR631	152-0141-02			SEMICONV DEVICE:SILICON,30V,150MA	01295	1N4152R
CR636	152-0141-02			SEMICONV DEVICE:SILICON,30V,150MA	01295	1N4152R
CR650	152-0141-02			SEMICONV DEVICE:SILICON,30V,150MA	01295	1N4152R
CR656	152-0141-02			SEMICONV DEVICE:SILICON,30V,150MA	01295	1N4152R
CR667	152-0141-02			SEMICONV DEVICE:SILICON,30V,150MA	01295	1N4152R
CR671	152-0141-02			SEMICONV DEVICE:SILICON,30V,150MA	01295	1N4152R
CR672	152-0071-00			SEMICONV DEVICE:GERMANIUM,15V,40MA	15238	G865
CR682	152-0071-00			SEMICONV DEVICE:GERMANIUM,15V,40MA	15238	G865
CR807	152-0141-02			SEMICONV DEVICE:SILICON,30V,150MA	01295	1N4152R
Q370	151-0220-00			TRANSISTOR:SILICON,PNP	07263	S036228
Q506	151-0190-00			TRANSISTOR:SILICON,NPN	07263	S032677
Q592	151-0220-00			TRANSISTOR:SILICON,PNP	07263	S036228
Q608	151-0220-00			TRANSISTOR:SILICON,PNP	07263	S036228
Q612	151-0219-00			TRANSISTOR:SILICON,PNP	07263	S022650
Q616	151-1007-00			TRANSISTOR:SILICON,FET,N-CHANNEL	80009	151-1007-00
Q618	151-0224-00			TRANSISTOR:SILICON,NPN	07263	SA24850
Q620	151-1025-00			TRANSISTOR:SILICON,JFE,N-CHANNEL	01295	SFB8129
Q626	151-0224-00			TRANSISTOR:SILICON,NPN	07263	SA24850
Q628	151-0220-00			TRANSISTOR:SILICON,PNP	07263	S036228
Q634	151-0041-00			TRANSISTOR:GERMANIUM,PNP	01295	2N1303
Q636	151-0219-00			TRANSISTOR:SILICON,PNP	07263	S022650

Replaceable Electrical Parts—7T11

Ckt No.	Tektronix Part No.	Serial/Model No. Eff	Dscont	Name & Description	Mfr Code	Mfr Part Number
Q644	151-0164-00			TRANSISTOR:SILICON,PNP	01295	SKB3334
Q650	151-0220-00			TRANSISTOR:SILICON,PNP	07263	S036228
Q652	151-0190-00			TRANSISTOR:SILICON,NPN	07263	S032677
Q654	151-0190-00			TRANSISTOR:SILICON,NPN	07263	S032677
Q656	151-1011-01			TRANSISTOR:SILICON,JFE,N-CHANNEL,DUAL	22229	FD1167
Q658	151-0224-00			TRANSISTOR:SILICON,NPN	07263	SA24850
Q662	151-0219-00			TRANSISTOR:SILICON,PNP	07263	S022650
Q664	151-0190-00			TRANSISTOR:SILICON,NPN	07263	S032677
Q668	151-0219-00			TRANSISTOR:SILICON,PNP	07263	S022650
Q670	151-0190-00			TRANSISTOR:SILICON,NPN	07263	S032677
Q674	151-0164-00	B010100	B199999	TRANSISTOR:SILICON,PNP	01295	SKB3334
Q674	151-0410-00	B200000		TRANSISTOR:SILICON,PNP	80009	151-0410-00
Q694	151-0188-00			TRANSISTOR:SILICON,PNP	04713	SPS6868K
Q714	151-0164-00			TRANSISTOR:SILICON,PNP	01295	SKB3334
R370	317-0472-00			RES.,FXD,CMPSN:4.7K OHM,5%,0.125W	01121	BB4725
R504	317-0303-00			RES.,FXD,CMPSN:30K OHM,5%,0.125W	01121	BB3035
R505	317-0563-00			RES.,FXD,CMPSN:56K OHM,5%,0.125W	01121	BB5635
R571	317-0103-00			RES.,FXD,CMPSN:10K OHM,5%,0.125W	01121	BB1035
R572	317-0103-00			RES.,FXD,CMPSN:10K OHM,5%,0.125W	01121	BB1035
R576	317-0105-00			RES.,FXD,CMPSN:1M OHM,5%,0.125W	01121	BB1055
R577	321-0289-00			RES.,FXD,FILM:10K OHM,1%,0.125W	91637	MFF1816G10001F
R581	321-0298-00			RES.,FXD,FILM:12.4K OHM,1%,0.125W	91637	MFF1816G12401F
R582	321-0356-00			RES.,FXD,FILM:49.9K OHM,1%,0.125W	91637	MFF1816G49901F
R583	321-0310-00			RES.,FXD,FILM:16.5K OHM,1%,0.125W	91637	MFF1816G16501F
R584	321-0327-00			RES.,FXD,FILM:24.9K OHM,1%,0.125W	91637	MFF1816G24901F
R585	321-0289-00			RES.,FXD,FILM:10K OHM,1%,0.125W	91637	MFF1816G10001F
R586	317-0511-00			RES.,FXD,CMPSN:510 OHM,5%,0.125W	01121	BB5115
R587	317-0223-00			RES.,FXD,CMPSN:22K OHM,5%,0.125W	01121	BB2235
R588	311-0607-00			RES.,VAR,NONWIR:10K OHM,10%,0.50W	73138	82-25-2
R591	316-0102-00	XB120000		RES.,FXD,CMPSN:1K OHM,10%,0.25W	01121	CB1021
R592	317-0104-00	B010100	B199999	RES.,FXD,CMPSN:100K OHM,5%,0.125W	01121	BB1045
R592	317-0513-00	B200000		RES.,FXD,CMPSN:51K OHM,5%,0.125W	01121	BB5135
R593	301-0822-00			RES.,FXD,CMPSN:8.2K OHM,5%,0.50W	01121	EB8225
R594	321-0260-00			RES.,FXD,FILM:4.99K OHM,1%,0.125W	91637	MFF1816G49900F
R596	317-0623-00			RES.,FXD,CMPSN:62K OHM,5%,0.125W	01121	BB6235
R597	317-0752-00	B010100	B079999X	RES.,FXD,CMPSN:7.5K OHM,5%,0.125W	01121	BB7525
R608	317-0303-00			RES.,FXD,CMPSN:30K OHM,5%,0.125W	01121	BB3035
R611	317-0472-00			RES.,FXD,CMPSN:4.7K OHM,5%,0.125W	01121	BB4725
R612	321-0400-00			RES.,FXD,FILM:143K OHM,1%,0.125W	91637	MFF1816G14302F
R613	317-0304-00			RES.,FXD,CMPSN:300K OHM,5%,0.125W	01121	BB3045
R614	321-0402-00			RES.,FXD,FILM:150K OHM,1%,0.125W	24546	NA55D1503F
R615	317-0106-00			RES.,FXD,CMPSN:10M OHM,5%,0.125W	01121	BB1065
R616	321-0342-00			RES.,FXD,FILM:35.7K OHM,1%,0.125W	91637	MFF1816G35701F
R618	321-0275-00			RES.,FXD,FILM:7.15K OHM,1%,0.125W	91637	MFF1816G71500F
R619	317-0106-00			RES.,FXD,CMPSN:10M OHM,5%,0.125W	01121	BB1065
R621	317-0513-00			RES.,FXD,CMPSN:51K OHM,5%,0.125W	01121	BB5135
R622	317-0752-00			RES.,FXD,CMPSN:7.5K OHM,5%,0.125W	01121	BB7525
R623	317-0104-00			RES.,FXD,CMPSN:100K OHM,5%,0.125W	01121	BB1045
R624	317-0153-00			RES.,FXD,CMPSN:15K OHM,5%,0.125W	01121	BB1535
R625	317-0101-00			RES.,FXD,CMPSN:100 OHM,5%,0.125W	01121	BB1015
R626	317-0512-00			RES.,FXD,CMPSN:5.1K OHM,5%,0.125	01121	BB5125
R628	317-0103-00			RES.,FXD,CMPSN:10K OHM,5%,0.125W	01121	BB1035
R629	317-0102-00			RES.,FXD,CMPSN:1K OHM,5%,0.125W	01121	BB1025
R631	317-0512-00			RES.,FXD,CMPSN:5.1K OHM,5%,0.125	01121	BB5125
R632	321-0259-00			RES.,FXD,FILM:4.87K OHM,1%,0.125W	91637	MFF1816G48700F
R633	321-0289-00			RES.,FXD,FILM:10K OHM,1%,0.125W	91637	MFF1816G10001F

Replaceable Electrical Parts—7T11

Ckt No.	Tektronix Part No.	Serial/Model No. Eff	Dscont	Name & Description	Mfr Code	Mfr Part Number
R634	317-0302-00			RES., FXD, CMPSN: 3K OHM, 5%, 0.125W	01121	BB3025
R636	317-0103-00			RES., FXD, CMPSN: 10K OHM, 5%, 0.125W	01121	BB1035
R641	317-0393-00	B010100	B079999X	RES., FXD, CMPSN: 39K OHM, 5%, 0.125W	01121	BB3935
R642	317-0273-00			RES., FXD, CMPSN: 27K OHM, 5%, 0.125W	01121	BB2735
R643	317-0303-00			RES., FXD, CMPSN: 30K OHM, 5%, 0.125W	01121	BB3035
R644	321-0289-00			RES., FXD, FILM: 10K OHM, 1%, 0.125W	91637	MFF1816G10001F
R645	311-0607-00			RES., VAR, NONWIR: 10K OHM, 10%, 0.50W	73138	82-25-2
R646	317-0243-00			RES., FXD, CMPSN: 24K OHM, 5%, 0.125W	01121	BB2435
R647	321-0289-00			RES., FXD, FILM: 10K OHM, 1%, 0.125W	91637	MFF1816G10001F
R650	317-0202-00			RES., FXD, CMPSN: 2K OHM, 5%, 0.125W	01121	BB2025
R651	317-0103-00			RES., FXD, CMPSN: 10K OHM, 5%, 0.125W	01121	BB1035
R658	317-0103-00			RES., FXD, CMPSN: 10K OHM, 5%, 0.125W	01121	BB1035
R662	317-0363-00			RES., FXD, CMPSN: 36K OHM, 5%, 0.125W	01121	BB3635
R663	317-0103-00			RES., FXD, CMPSN: 10K OHM, 5%, 0.125W	01121	BB1035
R664	317-0153-00			RES., FXD, CMPSN: 15K OHM, 5%, 0.125W	01121	BB1535
R665	317-0303-00			RES., FXD, CMPSN: 30K OHM, 5%, 0.125W	01121	BB3035
R666	317-0103-00			RES., FXD, CMPSN: 10K OHM, 5%, 0.125W	01121	BB1035
R667	321-0361-00			RES., FXD, FILM: 56.2K OHM, 1%, 0.125W	91637	MFF1816G56201F
R668	321-0277-00			RES., FXD, FILM: 7.5K OHM, 1%, 0.125W	91637	MFF1816G75000F
R669	317-0472-00			RES., FXD, CMPSN: 4.7K OHM, 5%, 0.125W	01121	BB4725
R670	317-0103-00			RES., FXD, CMPSN: 10K OHM, 5%, 0.125W	01121	BB1035
R671	317-0102-00			RES., FXD, CMPSN: 1K OHM, 5%, 0.125W	01121	BB1025
R672	317-0104-00	B010100	B029999	RES., FXD, CMPSN: 100K OHM, 5%, 0.125W	01121	BB1045
R672	317-0513-00	B030000		RES., FXD, CMPSN: 51K OHM, 5%, 0.125W	01121	BB5135
R673	321-0289-03			RES., FXD, FILM: 10K OHM, 0.25%, 0.125W	91637	MFF1816D10001C
R674	321-0289-03			RES., FXD, FILM: 10K OHM, 0.25%, 0.125W	91637	MFF1816D10001C
R675	317-0101-00			RES., FXD, CMPSN: 100 OHM, 5%, 0.125W	01121	BB1015
R676	321-0213-00			RES., FXD, FILM: 1.62K OHM, 1%, 0.125W	91637	MFF1816G16200F
R677	301-0133-00	B010100	B019999	RES., FXD, CMPSN: 13K OHM, 5%, 0.50W	01121	EB1335
R677	301-0113-00	B020000		RES., FXD, CMPSN: 11K OHM, 5%, 0.50W	01121	EB1135
R682	315-0222-00	XB070000		RES., FXD, CMPSN: 2.2K OHM, 5%, 0.25W	01121	CB2225
R683	317-0103-00			RES., FXD, CMPSN: 10K OHM, 5%, 0.125W	01121	BB1035
R684	317-0103-00			RES., FXD, CMPSN: 10K OHM, 5%, 0.125W	01121	BB1035
R685	317-0102-00	B010100	B099999X	RES., FXD, CMPSN: 1K OHM, 5%, 0.125W	01121	BB1025
R686	321-0213-00			RES., FXD, FILM: 1.62K OHM, 1%, 0.125W	91637	MFF1816G16200F
R687	301-0133-00	B010100	B019999	RES., FXD, CMPSN: 13K OHM, 5%, 0.50W	01121	EB1335
R687	301-0123-00	B020000		RES., FXD, CMPSN: 12K OHM, 5%, 0.50W	01121	EB1235
R691	317-0393-00			RES., FXD, CMPSN: 39K OHM, 5%, 0.125W	01121	BB3935
R692	317-0273-00			RES., FXD, CMPSN: 27K OHM, 5%, 0.125W	01121	BB2735
R693	317-0303-00			RES., FXD, CMPSN: 30K OHM, 5%, 0.125W	01121	BB3035
R694	317-0303-00			RES., FXD, CMPSN: 30K OHM, 5%, 0.125W	01121	BB3035
R714	317-0102-00			RES., FXD, CMPSN: 1K OHM, 5%, 0.125W	01121	BB1025
R807	315-0103-00			RES., FXD, CMPSN: 10K OHM, 5%, 0.25W	01121	CB1035
T650	120-0658-00			XFMR, TOROID: 2-40 TURN WINDINGS	80009	120-0658-00
U572	155-0035-00			MICROCIRCUIT, LI: QUAD OPERATIONAL AMPL	80009	155-0035-00

Replaceable Electrical Parts—7T11

Ckt No.	Tektronix Part No.	Serial/Model No. Eff	Dscont	Name & Description	Mfr Code	Mfr Part Number
	670-1119-00	B010100	B019999	CKT BOARD ASSY:TIMING	80009	670-1119-00
	670-1119-01	B020000	B029999	CKT BOARD ASSY:TIMING	80009	670-1119-01
	670-1119-02	B030000	B049999	CKT BOARD ASSY:TIMING	80009	670-1119-02
	670-1119-03	B050000	B079999	CKT BOARD ASSY:TIMING	80009	670-1119-03
	670-1119-04	B080000	B119999	CKT BOARD ASSY:TIMING	80009	670-1119-04
	670-1119-06	B120000	B139999	CKT BOARD ASSY:TIMING	80009	670-1119-06
	670-1119-07	B140000	B149999	CKT BOARD ASSY:TIMING	80009	670-1119-07
	670-1119-08	B150000	B212079	CKT BOARD ASSY:TIMING	80009	670-1119-08
	670-1119-09	B212080	B222994	CKT BOARD ASSY:TIMING	80009	670-1119-09
	670-1119-10	B222995	B233224	CKT BOARD ASSY:TIMING	80009	670-1119-10
	670-1119-11	B233225	B243233	CKT BOARD ASSY:TIMING	80009	670-1119-11
	670-1119-13	B243234		CKT BOARD ASSY:TIMING	80009	670-1119-13
C212	283-0060-00	B010100	B049999	CAP., FXD, CER DI: 100PF, 5%, 200V	72982	855-535U2J101J
C212	283-0599-00	B050000		CAP., FXD, MICA D: 98PF, 5%, 500V	00853	D105F980J0
C213	283-0121-00			CAP., FXD, CER DI: 0.001UF, 20%, 200V	56289	40C73A5
C215	283-0140-00			CAP., FXD, CER DI: 4.7PF, 5%, 50V	72982	8101E003A479C
C219	283-0121-00			CAP., FXD, CER DI: 0.001UF, 20%, 200V	56289	40C73A5
C221	283-0000-00			CAP., FXD, CER DI: 0.001UF, +100-0%, 500V	59660	831-519-Z5U-102P
C224	283-0000-00			CAP., FXD, CER DI: 0.001UF, +100-0%, 500V	59660	831-519-Z5U-102P
C228	283-0140-00			CAP., FXD, CER DI: 4.7PF, 5%, 50V	72982	8101E003A479C
C230	283-0003-00	B010100	B049999	CAP., FXD, CER DI: 0.01UF, +80-20%, 150V	91418	SP103Z151-4R9
C230	283-0204-00	B050000		CAP., FXD, CER DI: 0.01UF, 20%, 50V	72982	8121N061Z5U0103M
C232	283-0175-00			CAP., FXD, CER DI: 10PF, 5%, 200V	72982	8101B210C0G0100J
C234	283-0175-00			CAP., FXD, CER DI: 10PF, 5%, 200V	72982	8101B210C0G0100J
C237	281-0122-00			CAP., VAR, CER DI: 2.5-9PF, 100V	59660	518-000A2.5-9
C251	283-0140-00			CAP., FXD, CER DI: 4.7PF, 5%, 50V	72982	8101E003A479C
C253	283-0140-00			CAP., FXD, CER DI: 4.7PF, 5%, 50V	72982	8101E003A479C
C261	283-0121-00			CAP., FXD, CER DI: 0.001UF, 20%, 200V	56289	40C73A5
C263	283-0121-00			CAP., FXD, CER DI: 0.001UF, 20%, 200V	56289	40C73A5
C264	283-0135-00			CAP., FXD, CER DI: 100PF, 5%, 500V	56289	40C321A
C271	283-0121-00			CAP., FXD, CER DI: 0.001UF, 20%, 200V	56289	40C73A5
C273	283-0121-00			CAP., FXD, CER DI: 0.001UF, 20%, 200V	56289	40C73A5
C281	283-0177-00			CAP., FXD, CER DI: 1UF, +80-20%, 25V	56289	273C5
C291	281-0562-00			CAP., FXD, CER DI: 39PF, 10%, 500V	59660	301-000U2J0390K
C292	281-0123-00			CAP., VAR, CER DI: 5-25PF, 100V	59660	518-000A5-25
C294	281-0616-00			CAP., FXD, CER DI: 6.8PF, +/-0.5PF, 200V	59660	374-018-C0H0689D
C298	290-0340-00			CAP., FXD, ELCTLT: 10UF, 10%, 50V	56289	109D106X9050C2
C299	283-0177-00			CAP., FXD, CER DI: 1UF, +80-20%, 25V	56289	273C5
C301	283-0175-00			CAP., FXD, CER DI: 10PF, 5%, 200V	72982	8101B210C0G0100J
C308	283-0000-00			CAP., FXD, CER DI: 0.001UF, +100-0%, 500V	59660	831-519-Z5U-102P
C312	283-0175-00			CAP., FXD, CER DI: 10PF, 5%, 200V	72982	8101B210C0G0100J
C313	281-0123-00			CAP., VAR, CER DI: 5-25PF, 100V	59660	518-000A5-25
C316	283-0000-00			CAP., FXD, CER DI: 0.001UF, +100-0%, 500V	59660	831-519-Z5U-102P
C320	283-0175-00	XB080000		CAP., FXD, CER DI: 10PF, 5%, 200V	72982	8101B210C0G0100J
C322	283-0177-00			CAP., FXD, CER DI: 1UF, +80-20%, 25V	56289	273C5
C324	283-0154-00			CAP., FXD, CER DI: 22PF, 5%, 50V	72982	8111B061C0G220J
C328	283-0154-00	XB233225		CAP., FXD, CER DI: 22PF, 5%, 50V	72982	8111B061C0G220J
C342	283-0070-00			CAP., FXD, CER DI: 30PF, 10%, 50V	72982	8121-060C0G0300K
C344	283-0070-00			CAP., FXD, CER DI: 30PF, 10%, 50V	72982	8121-060C0G0300K
C346	283-0121-00			CAP., FXD, CER DI: 0.001UF, 20%, 200V	56289	40C73A5
C348	283-0076-00			CAP., FXD, CER DI: 27PF, 10%, 500V	56289	40C287A2
C349	283-0003-00	B010100	B049999	CAP., FXD, CER DI: 0.01UF, +80-20%, 150V	91418	SP103Z151-4R9
C349	283-0204-00	B050000		CAP., FXD, CER DI: 0.01UF, 20%, 50V	72982	8121N061Z5U0103M
C353	283-0072-01			CAP., FXD, CER DI: 0.01UF, +80-20%, 200V	51642	S-300-200Z5V103M
C356	283-0175-00			CAP., FXD, CER DI: 10PF, 5%, 200V	72982	8101B210C0G0100J
C358	283-0000-00			CAP., FXD, CER DI: 0.001UF, +100-0%, 500V	59660	831-519-Z5U-102P
C359	283-0000-00			CAP., FXD, CER DI: 0.001UF, +100-0%, 500V	59660	831-519-Z5U-102P

Ckt No.	Tektronix Part No.	Serial/Model No. Eff	Dscont	Name & Description	Mfr Code	Mfr Part Number
C369	283-0121-00			CAP., FXD, CER DI: 0.001UF, 20%, 200V	56289	40C73A5
C401	283-0150-00			CAP., FXD, CER DI: 650PF, 5%, 200V	59660	835-515B651J
C402	283-0060-00	B010100	B049999	CAP., FXD, CER DI: 100PF, 5%, 200V	72982	855-535U2J101J
C402	283-0599-00	B050000		CAP., FXD, MICA D: 98PF, 5%, 500V	00853	D105F980J0
C403	283-0060-00	B010100	B049999	CAP., FXD, CER DI: 100PF, 5%, 200V	72982	855-535U2J101J
C403	283-0599-00	B050000		CAP., FXD, MICA D: 98PF, 5%, 500V	00853	D105F980J0
C411	290-0269-00			CAP., FXD, ELCTLT: 0.22UF, 5%, 35V	56289	162D224X5035BC2
C412	290-0282-00			CAP., FXD, ELCTLT: 0.047UF, 10%, 35V	56289	162D473X9035BC2
C414	283-0004-00	B010100	B049999	CAP., FXD, CER DI: 0.02UF, +80-20%, 150V	91418	SP203Z151-4R9
C414	283-0191-00	B050000		CAP., FXD, CER DI: 0.022UF, 20%, 50V	72982	8121N075Z5U0223M
C416	283-0178-00			CAP., FXD, CER DI: 0.1UF, +80-20%, 100V	72982	8131N145651 104Z
C421	283-0239-00			CAP., FXD, CER DI: 0.022UF, 10%, 50V	72982	8121N083X7R0223K
C424	283-0067-00	XB212080		CAP., FXD, CER DI: 0.001UF, 10%, 200V	72982	DD51B10Y5F102K
C451	283-0000-00			CAP., FXD, CER DI: 0.001UF, +100-0%, 500V	59660	831-519-Z5U-102P
C455	283-0178-00			CAP., FXD, CER DI: 0.1UF, +80-20%, 100V	72982	8131N145651 104Z
C456	283-0000-00			CAP., FXD, CER DI: 0.001UF, +100-0%, 500V	59660	831-519-Z5U-102P
C463	283-0121-00			CAP., FXD, CER DI: 0.001UF, 20%, 200V	56289	40C73A5
C509	283-0003-00	B010100	B049999	CAP., FXD, CER DI: 0.01UF, +80-20%, 150V	91418	SP103Z151-4R9
C509	283-0204-00	B050000		CAP., FXD, CER DI: 0.01UF, 20%, 50V	72982	8121N061Z5U0103M
C512	283-0196-00			CAP., FXD, CER DI: 270PF, 10%, 50V	72982	8101B057X7R0271K
C518	283-0196-00			CAP., FXD, CER DI: 270PF, 10%, 50V	72982	8101B057X7R0271K
C551	283-0642-00			CAP., FXD, MICA D: 33PF, +/-0.5PF, 300V	00853	D10-5E330G
C555	283-0196-00	XB150000		CAP., FXD, CER DI: 270PF, 10%, 50V	72982	8101B057X7R0271K
C566	283-0182-00			CAP., FXD, CER DI: 51PF, 5%, 400V	72982	8121N400A510J
C573	283-0178-00			CAP., FXD, CER DI: 0.1UF, +80-20%, 100V	72982	8131N145651 104Z
C578	283-0144-00	B010100	B119999X	CAP., FXD, CER DI: 33PF, 1%, 500V	72982	801-547P2G330G
C603	283-0177-00			CAP., FXD, CER DI: 1UF, +80-20%, 25V	56289	273C5
C604	283-0000-00			CAP., FXD, CER DI: 0.001UF, +100-0%, 500V	59660	831-519-Z5U-102P
C821	283-0072-01			CAP., FXD, CER DI: 0.01UF, +80-20%, 200V	51642	S-300-200Z5V103M
C823	283-0121-00			CAP., FXD, CER DI: 0.001UF, 20%, 200V	56289	40C73A5
C824	283-0072-01			CAP., FXD, CER DI: 0.01UF, +80-20%, 200V	51642	S-300-200Z5V103M
C826	283-0072-01			CAP., FXD, CER DI: 0.01UF, +80-20%, 200V	51642	S-300-200Z5V103M
C827	283-0072-01			CAP., FXD, CER DI: 0.01UF, +80-20%, 200V	51642	S-300-200Z5V103M
CR212	152-0141-02			SEMICONV DEVICE: SILICON, 30V, 150MA	01295	1N4152R
CR234	152-0141-02			SEMICONV DEVICE: SILICON, 30V, 150MA	01295	1N4152R
CR244	152-0141-02			SEMICONV DEVICE: SILICON, 30V, 150MA	01295	1N4152R
CR251	152-0141-02			SEMICONV DEVICE: SILICON, 30V, 150MA	01295	1N4152R
CR284	152-0141-02			SEMICONV DEVICE: SILICON, 30V, 150MA	01295	1N4152R
CR294	152-0141-02			SEMICONV DEVICE: SILICON, 30V, 150MA	01295	1N4152R
CR295	152-0141-02			SEMICONV DEVICE: SILICON, 30V, 150MA	01295	1N4152R
CR296	152-0141-02			SEMICONV DEVICE: SILICON, 30V, 150MA	01295	1N4152R
CR303	152-0322-00			SEMICONV DEVICE: SILICON, 15V, HOT CARRIER	50434	5082-2672
CR304	152-0322-00			SEMICONV DEVICE: SILICON, 15V, HOT CARRIER	50434	5082-2672
CR305	152-0322-00			SEMICONV DEVICE: SILICON, 15V, HOT CARRIER	50434	5082-2672
CR316	152-0322-00			SEMICONV DEVICE: SILICON, 15V, HOT CARRIER	50434	5082-2672
CR328	152-0169-00	B010100	B233224X	SEMICONV DEVICE: TUNNEL, 1MA, 10PF	83508	1N3712
CR348	152-0141-02			SEMICONV DEVICE: SILICON, 30V, 150MA	01295	1N4152R
CR357	152-0141-02			SEMICONV DEVICE: SILICON, 30V, 150MA	01295	1N4152R
CR358	152-0141-02			SEMICONV DEVICE: SILICON, 30V, 150MA	01295	1N4152R
CR368	152-0141-02	XB080000		SEMICONV DEVICE: SILICON, 30V, 150MA	01295	1N4152R
CR400	152-0141-02			SEMICONV DEVICE: SILICON, 30V, 150MA	01295	1N4152R
CR405	152-0141-02			SEMICONV DEVICE: SILICON, 30V, 150MA	01295	1N4152R
CR406	152-0141-02			SEMICONV DEVICE: SILICON, 30V, 150MA	01295	1N4152R
CR411	152-0333-00			SEMICONV DEVICE: SILICON, 55V, 200MA	07263	FDH-6012
CR412	152-0333-00			SEMICONV DEVICE: SILICON, 55V, 200MA	07263	FDH-6012
CR414	152-0141-02	XB140000		SEMICONV DEVICE: SILICON, 30V, 150MA	01295	1N4152R
CR416	152-0141-02	XB140000		SEMICONV DEVICE: SILICON, 30V, 150MA	01295	1N4152R

Replaceable Electrical Parts—7T11

Ckt No.	Tektronix Part No.	Serial/Model No. Eff	Dscont	Name & Description	Mfr Code	Mfr Part Number
CR446	152-0141-02			SEMICON D DEVICE:SILICON,30V,150MA	01295	1N4152R
CR502	152-0141-02			SEMICON D DEVICE:SILICON,30V,150MA	01295	1N4152R
CR503	152-0141-02			SEMICON D DEVICE:SILICON,30V,150MA	01295	1N4152R
CR514	152-0071-00	XB150000		SEMICON D DEVICE:GERMANIUM,15V,40MA	15238	G865
CR515	152-0141-02			SEMICON D DEVICE:SILICON,30V,150MA	01295	1N4152R
CR525	152-0141-02			SEMICON D DEVICE:SILICON,30V,150MA	01295	1N4152R
CR527	152-0071-00	XB150000		SEMICON D DEVICE:GERMANIUM,15V,40MA	15238	G865
CR547	152-0322-00			SEMICON D DEVICE:SILICON,15V,HOT CARRIER	50434	5082-2672
CR562	152-0141-02			SEMICON D DEVICE:SILICON,30V,150MA	01295	1N4152R
J342	131-0265-00			CONNECTOR,RCPT,:RIGHT ANGLE MOUNT	98291	51-053-0000
J344	131-0265-00			CONNECTOR,RCPT,:RIGHT ANGLE MOUNT	98291	51-053-0000
Q212	151-0271-00			TRANSISTOR:SILICON,PNP	04713	SPS8236
Q214	151-0269-00			TRANSISTOR:SILICON,NPN,SEL FROM SE3005	07263	FMT5092
Q216	151-0282-00			TRANSISTOR:SILICON,NPN	80009	151-0282-00
Q218	151-0282-00			TRANSISTOR:SILICON,NPN	80009	151-0282-00
Q222	151-0220-00			TRANSISTOR:SILICON,PNP	07263	S036228
Q228	151-0202-00			TRANSISTOR:SILICON,PNP	80009	151-0202-00
Q230	151-0188-00			TRANSISTOR:SILICON,PNP	04713	SPS6868K
Q234	151-0190-00			TRANSISTOR:SILICON,NPN	07263	S032677
Q242	151-0224-00			TRANSISTOR:SILICON,NPN	07263	SA24850
Q244	151-0190-00			TRANSISTOR:SILICON,NPN	07263	S032677
Q252	151-0282-00			TRANSISTOR:SILICON,NPN	80009	151-0282-00
Q262	151-0202-00			TRANSISTOR:SILICON,PNP	80009	151-0202-00
Q272	151-0282-00			TRANSISTOR:SILICON,NPN	80009	151-0282-00
Q280	151-1011-01			TRANSISTOR:SILICON,JFE,N-CHANNEL,DUAL	22229	FD1167
Q282	151-0224-00			TRANSISTOR:SILICON,NPN	07263	SA24850
Q284	151-0219-00			TRANSISTOR:SILICON,PNP	07263	S022650
Q286	151-0224-00			TRANSISTOR:SILICON,NPN	07263	SA24850
Q294	151-1021-00			TRANSISTOR:SILICON,JFE	17856	FN815
Q304	151-0221-00			TRANSISTOR:SILICON,PNP	04713	SPS246
Q306	151-0221-00			TRANSISTOR:SILICON,PNP	04713	SPS246
Q308	151-0224-00			TRANSISTOR:SILICON,NPN	07263	SA24850
Q316	151-0190-00			TRANSISTOR:SILICON,NPN	07263	S032677
Q318	151-0188-00			TRANSISTOR:SILICON,PNP	04713	SPS6868K
Q322	151-0190-00	B010100	B079999	TRANSISTOR:SILICON,NPN	07263	S032677
Q322	151-0269-00	B080000		TRANSISTOR:SILICON,NPN,SEL FROM SE3005	07263	FMT5092
Q326	151-0164-00			TRANSISTOR:SILICON,PNP	01295	SKB3334
Q328	151-0083-00	B010100	B019999	TRANSISTOR:GERMANIUM,PNP	80009	151-0083-00
Q328	153-0592-00	B020000	B233224	TRANSISTOR:GE,PNP,SEL	80009	153-0592-00
Q328	151-0719-00	B233225		TRANSISTOR:SILICON,PNP	04713	SPS8226(MPSH81)
Q329	151-0367-00	XB233225		TRANSISTOR:SILICON,NPN,SEL FROM 3571TP	01295	SKA6516
Q342	151-0142-00			TRANSISTOR:SILICON,PNP	80009	151-0142-00
Q344	151-0142-00			TRANSISTOR:SILICON,PNP	80009	151-0142-00
Q352	151-0188-00			TRANSISTOR:SILICON,PNP	04713	SPS6868K
Q356	151-0225-00			TRANSISTOR:SILICON,NPN	07263	S39291
Q362	151-0188-00			TRANSISTOR:SILICON,PNP	04713	SPS6868K
Q368	151-0190-00			TRANSISTOR:SILICON,NPN	07263	S032677
Q400	151-0190-00			TRANSISTOR:SILICON,NPN	07263	S032677
Q402	151-0190-00			TRANSISTOR:SILICON,NPN	07263	S032677
Q404	151-0188-00			TRANSISTOR:SILICON,PNP	04713	SPS6868K
Q406	151-0190-00			TRANSISTOR:SILICON,NPN	07263	S032677
Q414	151-0069-00	B010100	B139999	TRANSISTOR:GERMANIUM,NPN	53399	2N1304
Q414	151-0302-00	B140000		TRANSISTOR:SILICON,NPN	07263	S038487
Q416	151-0069-00	B010100	B139999	TRANSISTOR:GERMANIUM,NPN	53399	2N1304
Q416	151-0302-00	B140000		TRANSISTOR:SILICON,NPN	07263	S038487
Q422	151-1012-00	B010100	B029999	TRANSISTOR:SILICON,FE,N-CHANNEL	80009	151-1012-00

Ckt No.	Tektronix Part No.	Serial/Model No. Eff	Dscont	Name & Description	Mfr Code	Mfr Part Number
Q422	151-1005-00	B030000		TRANSISTOR:SILICON,JFE,N-CHANNEL	80009	151-1005-00
Q424	151-0224-00			TRANSISTOR:SILICON,NPN	07263	SA24850
Q434	151-0192-00			TRANSISTOR:SILICON,NPN,SEL FROM MPS6521	04713	SPS8801
Q438	151-0192-00			TRANSISTOR:SILICON,NPN,SEL FROM MPS6521	04713	SPS8801
Q446	151-0225-00			TRANSISTOR:SILICON,NPN	07263	S39291
Q448	151-0225-00			TRANSISTOR:SILICON,NPN	07263	S39291
Q452	151-1011-01			TRANSISTOR:SILICON,JFE,N-CHANNEL,DUAL	22229	FD1167
Q454	151-0220-00			TRANSISTOR:SILICON,PNP	07263	S036228
Q462	151-0164-00			TRANSISTOR:SILICON,PNP	01295	SKB3334
Q464	151-0224-00			TRANSISTOR:SILICON,NPN	07263	SA24850
Q512	151-0220-00			TRANSISTOR:SILICON,PNP	07263	S036228
Q514	151-0225-00	B010100	B019999	TRANSISTOR:SILICON,NPN	07263	S39291
Q514	153-0588-00	B020000		TRANSISTOR:2N3563 FAMILY,SELECTED	80009	153-0588-00
Q524	151-0225-00	B010100	B019999	TRANSISTOR:SILICON,NPN	07263	S39291
Q524	153-0588-00	B020000		TRANSISTOR:2N3563 FAMILY,SELECTED	80009	153-0588-00
Q542	151-0164-00			TRANSISTOR:SILICON,PNP	01295	SKB3334
Q544	151-0207-00			TRANSISTOR:SILICON,NPN	03508	X32D6191
Q546	151-0188-00			TRANSISTOR:SILICON,PNP	04713	SPS6868K
Q552	151-0190-00			TRANSISTOR:SILICON,NPN	07263	S032677
Q554	151-0041-00			TRANSISTOR:GERMANIUM,PNP	01295	2N1303
Q555	151-0269-00	XB150000		TRANSISTOR:SILICON,NPN,SEL FROM SE3005	07263	FMT5092
Q556	151-1021-00			TRANSISTOR:SILICON,JFE	17856	FN815
Q560	151-1007-00			TRANSISTOR:SILICON,FET,N-CHANNEL	80009	151-1007-00
Q564	151-0219-00			TRANSISTOR:SILICON,PNP	07263	S022650
Q568	151-0224-00			TRANSISTOR:SILICON,NPN	07263	SA24850
Q724	151-0207-00			TRANSISTOR:SILICON,NPN	03508	X32D6191
Q734	151-0207-00			TRANSISTOR:SILICON,NPN	03508	X32D6191
R211	317-0103-00			RES.,FXD,CMPSN:10K OHM,5%,0.125W	01121	BB1035
R212	317-0104-00			RES.,FXD,CMPSN:100K OHM,5%,0.125W	01121	BB1045
R213	317-0103-00			RES.,FXD,CMPSN:10K OHM,5%,0.125W	01121	BB1035
R214	317-0302-00			RES.,FXD,CMPSN:3K OHM,5%,0.125W	01121	BB3025
R215	317-0102-00			RES.,FXD,CMPSN:1K OHM,5%,0.125W	01121	BB1025
R216	317-0101-00			RES.,FXD,CMPSN:100 OHM,5%,0.125W	01121	BB1015
R217	317-0103-00			RES.,FXD,CMPSN:10K OHM,5%,0.125W	01121	BB1035
R218	317-0102-00			RES.,FXD,CMPSN:1K OHM,5%,0.125W	01121	BB1025
R219	317-0103-00	B010100	B149999	RES.,FXD,CMPSN:10K OHM,5%,0.125W	01121	BB1035
R219	317-0332-00	B150000		RES.,FXD,CMPSN:3.3K OHM,5%,0.125W	01121	BB3325
R221	317-0273-00			RES.,FXD,CMPSN:27K OHM,5%,0.125W	01121	BB2735
R222	317-0303-00			RES.,FXD,CMPSN:30K OHM,5%,0.125W	01121	BB3035
R223	317-0273-00			RES.,FXD,CMPSN:27K OHM,5%,0.125W	01121	BB2735
R224	317-0303-00			RES.,FXD,CMPSN:30K OHM,5%,0.125W	01121	BB3035
R225	317-0303-00			RES.,FXD,CMPSN:30K OHM,5%,0.125W	01121	BB3035
R226	317-0392-00			RES.,FXD,CMPSN:3.9K OHM,5%,0.125W	01121	BB3925
R227	317-0101-00			RES.,FXD,CMPSN:100 OHM,5%,0.125W	01121	BB1015
R228	317-0200-00			RES.,FXD,CMPSN:20 OHM,5%,0.125W	01121	BB2005
R232	317-0563-00			RES.,FXD,CMPSN:56K OHM,5%,0.125W	01121	BB5635
R233	317-0103-00			RES.,FXD,CMPSN:10K OHM,5%,0.125W	01121	BB1035
R234	317-0623-00			RES.,FXD,CMPSN:62K OHM,5%,0.125W	01121	BB6235
R241	317-0303-00			RES.,FXD,CMPSN:30K OHM,5%,0.125W	01121	BB3035
R242	317-0363-00			RES.,FXD,CMPSN:36K OHM,5%,0.125W	01121	BB3635
R243	317-0203-00			RES.,FXD,CMPSN:20K OHM,5%,0.125W	01121	BB2035
R251	317-0102-00			RES.,FXD,CMPSN:1K OHM,5%,0.125W	01121	BB1025
R252	317-0103-00			RES.,FXD,CMPSN:10K OHM,5%,0.125W	01121	BB1035
R253	317-0200-00			RES.,FXD,CMPSN:20 OHM,5%,0.125W	01121	BB2005
R260	311-0609-00			RES.,VAR,NONWLR:2K OHM,10%,0.50W	73138	82-26-1
R261	323-0282-00			RES.,FXD,FILM:8.45K OHM,1%,0.50W	75042	CECT0-8451F
R262	317-0302-00			RES.,FXD,CMPSN:3K OHM,5%,0.125W	01121	BB3025

Replaceable Electrical Parts—7T11

Ckt No.	Tektronix Part No.	Serial/Model No. Eff	Dscont	Name & Description	Mfr Code	Mfr Part Number
R263	317-0202-00			RES., FXD, CMPSN: 2K OHM, 5%, 0.125W	01121	BB2025
R264	317-0101-00			RES., FXD, CMPSN: 100 OHM, 5%, 0.125W	01121	BB1015
R265	311-0660-00			RES., VAR, NONWIR: TRMR, 200K OHM, 0.5W	73138	82-35-1
R266	322-0473-00			RES., FXD, FILM: 825K OHM, 1%, 0.25W	75042	CEBTO-8253F
R270	311-1016-00	B010100	B109999	RES., VAR, NONWIR: TRMR, 2K OHM, 0.5W	01121	SV2021
R270	311-1265-00	B110000		RES., VAR, NONWIR: 2K OHM, 10%, 0.50W	32997	3329P-L58-202
R271	323-0282-00			RES., FXD, FILM: 8.45K OHM, 1%, 0.50W	75042	CECTO-8451F
R272	317-0202-00			RES., FXD, CMPSN: 2K OHM, 5%, 0.125W	01121	BB2025
R273	317-0133-00			RES., FXD, CMPSN: 13K OHM, 5%, 0.125W	01121	BB1335
R274	317-0101-00			RES., FXD, CMPSN: 100 OHM, 5%, 0.125W	01121	BB1015
R281	321-0246-00			RES., FXD, FILM: 3.57K OHM, 1%, 0.125W	91637	MFF1816G35700F
R282	321-0246-00			RES., FXD, FILM: 3.57K OHM, 1%, 0.125W	91637	MFF1816G35700F
R283	321-0342-00			RES., FXD, FILM: 35.7K OHM, 1%, 0.125W	91637	MFF1816G35701F
R284	317-0511-00			RES., FXD, CMPSN: 510 OHM, 5%, 0.125W	01121	BB5115
R285	301-0392-00			RES., FXD, CMPSN: 3.9K OHM, 5%, 0.50W	01121	EB3925
R286	317-0103-00			RES., FXD, CMPSN: 10K OHM, 5%, 0.125W	01121	BB1035
R287	321-0289-00			RES., FXD, FILM: 10K OHM, 1%, 0.125W	91637	MFF1816G10001F
R294	317-0683-00			RES., FXD, CMPSN: 68K OHM, 5%, 0.125W	01121	BB6835
R296	317-0203-00			RES., FXD, CMPSN: 20K OHM, 5%, 0.125W	01121	BB2035
R299	315-0622-00			RES., FXD, CMPSN: 6.2K OHM, 5%, 0.25W	01121	CB6225
R301	317-0303-00			RES., FXD, CMPSN: 30K OHM, 5%, 0.125W	01121	BB3035
R302	317-0103-00			RES., FXD, CMPSN: 10K OHM, 5%, 0.125W	01121	BB1035
R304	317-0103-00			RES., FXD, CMPSN: 10K OHM, 5%, 0.125W	01121	BB1035
R308	317-0101-00			RES., FXD, CMPSN: 100 OHM, 5%, 0.125W	01121	BB1015
R309	321-0272-00	B010100	B019999	RES., FXD, FILM: 6.65K OHM, 1%, 0.125W	91637	MFF1816G66500F
R309	321-0270-00	B020000		RES., FXD, FILM: 6.34K OHM, 1%, 0.125W	91637	MFF1816G63400F
R310	311-0732-00	B100100	B109999	RES., VAR, NONWIR: TRMR, 1K OHM, 0.5W	01121	SV1021
R310	311-1263-00	B110000		RES., VAR, NONWIR: 1K OHM, 10%, 0.50W	32997	3329P-L58-102
R320	317-0392-00			RES., FXD, CMPSN: 3.9K OHM, 5%, 0.125W	01121	BB3925
R321	317-0103-00			RES., FXD, CMPSN: 10K OHM, 5%, 0.125W	01121	BB1035
R324	317-0153-00			RES., FXD, CMPSN: 15K OHM, 5%, 0.125W	01121	BB1535
R325	317-0102-00	B010100	B323224	RES., FXD, CMPSN: 1K OHM, 5%, 0.125W	01121	BB1025
R325	317-0470-00	B323225		RES., FXD, CMPSN: 47 OHM, 5%, 0.125W	01121	BB4705
R326	317-0303-00			RES., FXD, CMPSN: 30K OHM, 5%, 0.125W	01121	BB3035
R327	317-0303-00			RES., FXD, CMPSN: 30K OHM, 5%, 0.125W	01121	BB3035
R328	317-0681-00	XB323225		RES., FXD, CMPSN: 680 OHM, 5%, 0.125W	01121	BB6815
R329	317-0512-00			RES., FXD, CMPSN: 5.1K OHM, 5%, 0.125	01121	BB5125
R330	317-0123-00	XB243234		RES., FXD, CMPSN: 12K OHM, 5%, 0.125W	01121	BB1235
R341	317-0913-00			RES., FXD, CMPSN: 91K OHM, 5%, 0.125W	01121	BB9135
R342	317-0102-00			RES., FXD, CMPSN: 1K OHM, 5%, 0.125W	01121	BB1025
R344	317-0102-00			RES., FXD, CMPSN: 1K OHM, 5%, 0.125W	01121	BB1025
R346	317-0100-00			RES., FXD, CMPSN: 10 OHM, 5%, 0.125W	01121	BB1005
R348	317-0303-00			RES., FXD, CMPSN: 30K OHM, 5%, 0.125W	01121	BB3035
R351	317-0472-00			RES., FXD, CMPSN: 4.7K OHM, 5%, 0.125W	01121	BB4725
R353	317-0100-00			RES., FXD, CMPSN: 10 OHM, 5%, 0.125W	01121	BB1005
R355	317-0103-00			RES., FXD, CMPSN: 10K OHM, 5%, 0.125W	01121	BB1035
R356	317-0103-00			RES., FXD, CMPSN: 10K OHM, 5%, 0.125W	01121	BB1035
R357	317-0102-00			RES., FXD, CMPSN: 1K OHM, 5%, 0.125W	01121	BB1025
R358	317-0822-00			RES., FXD, CMPSN: 8.2K OHM, 5%, 0.125W	01121	BB8225
R359	317-0471-00			RES., FXD, CMPSN: 470 OHM, 5%, 0.125W	01121	BB4715
R361	317-0103-00			RES., FXD, CMPSN: 10K OHM, 5%, 0.125W	01121	BB1035
R362	317-0472-00			RES., FXD, CMPSN: 4.7K OHM, 5%, 0.125W	01121	BB4725
R363	317-0102-00			RES., FXD, CMPSN: 1K OHM, 5%, 0.125W	01121	BB1025
R365	317-0393-00			RES., FXD, CMPSN: 39K OHM, 5%, 0.125W	01121	BB3935
R366	317-0433-00			RES., FXD, CMPSN: 43K OHM, 5%, 0.125W	01121	BB4335
R368	317-0471-00	B010100	B079999X	RES., FXD, CMPSN: 470 OHM, 5%, 0.125W	01121	BB4715
R401	317-0102-00			RES., FXD, CMPSN: 1K OHM, 5%, 0.125W	01121	BB1025

Ckt No.	Tektronix Part No.	Serial/Model No. Eff	Dscont	Name & Description	Mfr Code	Mfr Part Number
R402	317-0472-00			RES., FXD, CMPSN: 4.7K OHM, 5%, 0.125W	01121	BB4725
R403	317-0472-00			RES., FXD, CMPSN: 4.7K OHM, 5%, 0.125W	01121	BB4725
R404	317-0103-00			RES., FXD, CMPSN: 10K OHM, 5%, 0.125W	01121	BB1035
R405	317-0472-00			RES., FXD, CMPSN: 4.7K OHM, 5%, 0.125W	01121	BB4725
R406	317-0752-00			RES., FXD, CMPSN: 7.5K OHM, 5%, 0.125W	01121	BB7525
R408	317-0183-00			RES., FXD, CMPSN: 18K OHM, 5%, 0.125W	01121	BB1835
R409	317-0393-00			RES., FXD, CMPSN: 39K OHM, 5%, 0.125W	01121	BB3935
R411	317-0243-00			RES., FXD, CMPSN: 24K OHM, 5%, 0.125W	01121	BB2435
R412	317-0822-00			RES., FXD, CMPSN: 8.2K OHM, 5%, 0.125W	01121	BB8225
R415	317-0513-00			RES., FXD, CMPSN: 51K OHM, 5%, 0.125W	01121	BB5135
R422	317-0102-00			RES., FXD, CMPSN: 1K OHM, 5%, 0.125W	01121	BB1025
R423	315-0103-00			RES., FXD, CMPSN: 10K OHM, 5%, 0.25W	01121	CB1035
R424	317-0202-00			RES., FXD, CMPSN: 2K OHM, 5%, 0.125W	01121	BB2025
R432	321-0318-00			RES., FXD, FILM: 20K OHM, 1%, 0.125W	91637	MFF1816G20001F
R433	317-0203-00			RES., FXD, CMPSN: 20K OHM, 5%, 0.125W	01121	BB2035
R434	317-0433-00			RES., FXD, CMPSN: 43K OHM, 5%, 0.125W	01121	BB4335
R435	321-0320-00			RES., FXD, FILM: 21K OHM, 1%, 0.125W	91637	MFF1816G21001F
R436	321-0385-00			RES., FXD, FILM: 100K OHM, 1%, 0.125W	91637	MFF1816G10002F
R437	317-0393-00			RES., FXD, CMPSN: 39K OHM, 5%, 0.125W	01121	BB3935
R438	317-0512-00			RES., FXD, CMPSN: 5.1K OHM, 5%, 0.125	01121	BB5125
R439	317-0103-00			RES., FXD, CMPSN: 10K OHM, 5%, 0.125W	01121	BB1035
R440	311-0883-00	B010100	B109999	RES., VAR, NONWIR: 50K OHM, 0.50W	01121	SV5031
R440	311-1271-00	B110000		RES., VAR, NONWIR: 50K OHM, 10%, 0.50W	32997	3329P-L58-503
R441	321-0381-00			RES., FXD, FILM: 90.9K OHM, 1%, 0.125W	91637	MFF1816G90901F
R442	317-0274-00	B010100	B079999	RES., FXD, CMPSN: 270K OHM, 5%, 0.125W	01121	BB2745
R442	317-0224-00	B080000		RES., FXD, CMPSN: 220K OHM, 5%, 0.125W	01121	BB2245
R443	317-0274-00			RES., FXD, CMPSN: 270K OHM, 5%, 0.125W	01121	BB2745
R445	317-0103-00			RES., FXD, CMPSN: 10K OHM, 5%, 0.125W	01121	BB1035
R452	317-0513-00			RES., FXD, CMPSN: 51K OHM, 5%, 0.125W	01121	BB5135
R453	317-0203-00			RES., FXD, CMPSN: 20K OHM, 5%, 0.125W	01121	BB2035
R454	317-0153-00			RES., FXD, CMPSN: 15K OHM, 5%, 0.125W	01121	BB1535
R456	317-0102-00			RES., FXD, CMPSN: 1K OHM, 5%, 0.125W	01121	BB1025
R458	317-0102-00			RES., FXD, CMPSN: 1K OHM, 5%, 0.125W	01121	BB1025
R462	315-0333-00			RES., FXD, CMPSN: 33K OHM, 5%, 0.25W	01121	CB3335
R463	317-0100-00			RES., FXD, CMPSN: 10 OHM, 5%, 0.125W	01121	BB1005
R464	317-0243-00			RES., FXD, CMPSN: 24K OHM, 5%, 0.125W	01121	BB2435
R500	311-0840-00	B010100	B109999	RES., VAR, NONWIR: TRMR, 20K OHM, 0.5W	73138	91-103-0
R500	311-1269-00	B110000		RES., VAR, NONWIR: 20K OHM, 10%, 0.50W	32997	3329P-L58-203
R501	317-0104-00			RES., FXD, CMPSN: 100K OHM, 5%, 0.125W	01121	BB1045
R502	317-0913-00			RES., FXD, CMPSN: 91K OHM, 5%, 0.125W	01121	BB9135
R407	321-0331-00			RES., FXD, FILM: 27.4K OHM, 1%, 0.125W	91637	MFF1816G27401F
R508	315-0475-00			RES., FXD, CMPSN: 4.7M OHM, 5%, 0.25W	01121	CB4755
R509	321-0358-00			RES., FXD, FILM: 52.3K OHM, 1%, 0.125W	91637	MFF1816G52301F
R510	317-0104-00			RES., FXD, CMPSN: 100K OHM, 5%, 0.125W	01121	BB1045
R511	317-0125-00	B010100	B079999	RES., FXD, CMPSN: 1.2M OHM, 5%, 0.125W	01121	BB1255
R511	317-0335-00	B080000		RES., FXD, CMPSN: 3.3M OHM, 5%, 0.125W	01121	BB3355
R512	317-0101-00			RES., FXD, CMPSN: 100 OHM, 5%, 0.125W	01121	BB1015
R513	315-0153-00	B010100	B029999	RES., FXD, CMPSN: 15K OHM, 5%, 0.25W	01121	CB1535
R513	315-0330-00	B030000		RES., FXD, CMPSN: 33 OHM, 5%, 0.25W	01121	CB3305
R514	317-0103-00			RES., FXD, CMPSN: 10K OHM, 5%, 0.125W	01121	BB1035
R515	321-1381-03			RES., FXD, FILM: 92K OHM, 0.25%, 0.125W	91637	MFF1816D92001C
R516	317-0513-00			RES., FXD, CMPSN: 51K OHM, 5%, 0.125W	01121	BB5135
R517	321-0289-03			RES., FXD, FILM: 10K OHM, 0.25%, 0.125W	91637	MFF1816D10001C
R518	317-0101-00			RES., FXD, CMPSN: 100 OHM, 5%, 0.125W	01121	BB1015
R523	317-0103-00			RES., FXD, CMPSN: 10K OHM, 5%, 0.125W	01121	BB1035
R525	321-0381-03			RES., FXD, FILM: 90.9K OHM, 0.25%, 0.125W	91637	MFF1816D90901C
R526	317-0513-00			RES., FXD, CMPSN: 51K OHM, 5%, 0.125W	01121	BB5135

Replaceable Electrical Parts—7T11

Ckt No.	Tektronix Part No.	Serial/Model No. Eff	Dscont	Name & Description	Mfr Code	Mfr Part Number
R527	321-0289-03			RES., FXD, FILM:10K OHM, 0.25%, 0.125W	91637	MFF1816D10001C
R528	317-0104-00			RES., FXD, CMPSN:100K OHM, 5%, 0.125W	01121	BB1045
R533	321-0289-03			RES., FXD, FILM:10K OHM, 0.25%, 0.125W	91637	MFF1816D10001C
R534	321-0745-03			RES., FXD, FILM:25.05K OHM, 0.25%, 0.125W	91637	MFF1816D25051C
R535	321-0310-00			RES., FXD, FILM:16.5K OHM, 1%, 0.125W	91637	MFF1816G16501F
R536	321-0769-03			RES., FXD, FILM:50.33K OHM, 0.25%, 0.125W	91637	MFF1816D50331C
R537	321-0298-00			RES., FXD, FILM:12.4K OHM, 1%, 0.125W	91637	MFF1816G12401F
R541	317-0273-00			RES., FXD, CMPSN:27K OHM, 5%, 0.125W	01121	BB2735
R542	317-0303-00			RES., FXD, CMPSN:30K OHM, 5%, 0.125W	01121	BB3035
R543	317-0303-00			RES., FXD, CMPSN:30K OHM, 5%, 0.125W	01121	BB3035
R544	317-0103-00			RES., FXD, CMPSN:10K OHM, 5%, 0.125W	01121	BB1035
R546	317-0103-00			RES., FXD, CMPSN:10K OHM, 5%, 0.125W	01121	BB1035
R547	317-0271-00			RES., FXD, CMPSN:270 OHM, 5%, 0.125W	01121	BB2715
R548	317-0302-00			RES., FXD, CMPSN:3K OHM, 5%, 0.125W	01121	BB3025
R549	317-0102-00			RES., FXD, CMPSN:1K OHM, 5%, 0.125W	01121	BB1025
R550	311-1016-00	B010100	B109999	RES., VAR, NONWIR:TRMR, 2K OHM, 0.5W	01121	SV2021
R550	311-1265-00	B110000		RES., VAR, NONWIR:2K OHM, 10%, 0.50W	32997	3329P-L58-202
R551	317-0102-00			RES., FXD, CMPSN:1K OHM, 5%, 0.125W	01121	BB1025
R552	317-0473-00	XB150000		RES., FXD, CMPSN:47K OHM, 5%, 0.125W	01121	BB4735
R553	321-0289-00			RES., FXD, FILM:10K OHM, 1%, 0.125W	91637	MFF1816G10001F
R554	321-0265-00			RES., FXD, FILM:5.62K OHM, 1%, 0.125W	91637	MFF1816G56200F
R555	317-0101-00	XB150000		RES., FXD, CMPSN:100 OHM, 5%, 0.125W	01121	BB1015
R556	321-0193-00			RES., FXD, FILM:1K OHM, 1%, 0.125W	91637	MFF1816G10000F
R557	321-0263-00			RES., FXD, FILM:5.36K OHM, 1%, 0.125W	91637	MFF1816G53600F
R558	321-0222-00			RES., FXD, FILM:2K OHM, 1%, 0.125W	91637	MFF1816G20000F
R559	317-0104-00	XB080000		RES., FXD, CMPSN:100K OHM, 5%, 0.125W	01121	BB1045
R561	317-0273-00			RES., FXD, CMPSN:27K OHM, 5%, 0.125W	01121	BB2735
R562	317-0363-00			RES., FXD, CMPSN:36K OHM, 5%, 0.125W	01121	BB3635
R565	321-0289-00			RES., FXD, FILM:10K OHM, 1%, 0.125W	91637	MFF1816G10001F
R567	315-0681-00			RES., FXD, CMPSN:680 OHM, 5%, 0.25W	01121	CB6815
R568	317-0682-00			RES., FXD, CMPSN:6.8K OHM, 5%, 0.125W	01121	BB6825
R569	317-0682-00			RES., FXD, CMPSN:6.8K OHM, 5%, 0.125W	01121	BB6825
R572	317-0101-00	XB222995		RES., FXD, CMPSN:100 OHM, 5%, 0.125W	01121	BB1015
R573	321-0318-00	B010100	B149999	RES., FXD, FILM:20K OHM, 1%, 0.125W	91637	MFF1816G20001F
R573	321-0317-00	B150000		RES., FXD, FILM:19.6K OHM, 1%, 0.125W	91637	MFF1816G19601F
R574	317-0205-00			RES., FXD, CMPSN:2M OHM, 5%, 0.125W	01121	BB2055
R575	317-0107-00	XB020000	B149999X	RES., FXD, CMPSN:100M OHM, 5%, 0.125W (R575, ADDED IF NECESSARY)	01121	BB1075
R578	317-0107-00	B010100	B119999X	RES., FXD, CMPSN:100M OHM, 5%, 0.125W	01121	BB1075
R579	317-0107-00	B010100	B119999X	RES., FXD, CMPSN:100M OHM, 5%, 0.125W	01121	BB1075
R600	311-0732-00	B010100	B109999	RES., VAR, NONWIR:TRMR, 1K OHM, 0.5W	01121	SV1021
R600	311-1263-00	B110000		RES., VAR, NONWIR:1K OHM, 10%, 0.50W	32997	3329P-L58-102
R601	321-0231-00			RES., FXD, FILM:2.49K OHM, 1%, 0.125W	91637	MFF1816G24900F
R602	321-0271-00			RES., FXD, FILM:6.49K OHM, 1%, 0.125W	91637	MFF1816G64900F
R603	317-0472-00			RES., FXD, CMPSN:4.7K OHM, 5%, 0.125W	01121	BB4725
R724	315-0102-00			RES., FXD, CMPSN:1K OHM, 5%, 0.25W	01121	CB1025
R734	317-0153-00	B010100	B019999	RES., FXD, CMPSN:15K OHM, 5%, 0.125W	01121	BB1535
R734	317-0332-00	B020000		RES., FXD, CMPSN:3.3K OHM, 5%, 0.125W	01121	BB3325
R821	317-0100-00			RES., FXD, CMPSN:10 OHM, 5%, 0.125W	01121	BB1005
R823	317-0100-00			RES., FXD, CMPSN:10 OHM, 5%, 0.125W	01121	BB1005
R824	317-0100-00			RES., FXD, CMPSN:10 OHM, 5%, 0.125W	01121	BB1005
R826	317-0100-00			RES., FXD, CMPSN:10 OHM, 5%, 0.125W	01121	BB1005
R827	317-0100-00			RES., FXD, CMPSN:10 OHM, 5%, 0.125W	01121	BB1005
T400	120-0658-00			XFMR, TOROID:2-40 TURN WINDINGS	80009	120-0658-00
T446	120-0658-00			XFMR, TOROID:2-40 TURN WINDINGS	80009	120-0658-00
U512	155-0035-00			MICROCIRCUIT, LI:QUAD OPERATIONAL AMPL	80009	155-0035-00
U602	156-0053-00			MICROCIRCUIT, LI:VOLTAGE REGULATOR	07263	SL21721
VR219	152-0279-00			SEMICONV DEVICE:ZENER, 0.4W, 5.1V, 5%	04713	SZG35010RL
VR299	152-0127-00			SEMICONV DEVICE:ZENER, 0.4W, 7.5V, 5%	04713	SZG35009K2

Ckt No.	Tektronix Part No.	Serial/Model No. Eff	Dscont	Name & Description	Mfr Code	Mfr Part Number
	670-1120-00	B010100	B019999	CKT BOARD ASSY:TRIGGER	80009	670-1120-00
	670-1120-01	B020000	B049999	CKT BOARD ASSY:TRIGGER	80009	670-1120-01
	670-1120-02	B050000	B079999	CKT BOARD ASSY:TRIGGER	80009	670-1120-02
	670-1120-03	B080000	B129999	CKT BOARD ASSY:TRIGGER	80009	670-1120-03
	670-1120-04	B130000	B222994	CKT BOARD ASSY:TRIGGER	80009	670-1120-04
	670-1120-05	B222995		CKT BOARD ASSY:TRIGGER	80009	670-1120-05
C14	283-0072-01			CAP., FXD, CER DI:0.01UF, +80-20%, 200V	51642	S-300-200Z5V103M
C20	283-0000-00			CAP., FXD, CER DI:0.001UF, +100-0%, 500V	59660	831-519-25U-102P
C25	283-0197-00			CAP., FXD, CER DI:470PF, 5%, 100V	72982	8121N075COG0471J
C26	283-0121-00			CAP., FXD, CER DI:0.001UF, 20%, 200V	56289	40C73A5
C27	283-0216-00			CAP., FXD, CER DI:1.5PF, 10%, 50V	72982	8300 000C0G159B
C28	283-0175-00			CAP., FXD, CER DI:10PF, 5%, 200V	72982	8101B210C0G0100J
C29	283-0175-00			CAP., FXD, CER DI:10PF, 5%, 200V	72982	8101B210C0G0100J
C33	283-0072-01			CAP., FXD, CER DI:0.01UF, +80-20%, 200V	51642	S-300-200Z5V103M
C37	283-0177-00			CAP., FXD, CER DI:1UF, +80-20%, 25V	56289	273C5
C39	283-0121-00			CAP., FXD, CER DI:0.001UF, 20%, 200V	56289	40C73A5
C43	283-0139-00			CAP., FXD, CER DI:150PF, 20%, 50V	51642	W100-050-X5F151M
C48	283-0072-01			CAP., FXD, CER DI:0.01UF, +80-20%, 200V	51642	S-300-200Z5V103M
C51	283-0121-00			CAP., FXD, CER DI:0.001UF, 20%, 200V	56289	40C73A5
C53	283-0047-00			CAP., FXD, CER DI:270PF, 5%, 500V	72982	0831522Z5D00271J
C63	283-0121-00			CAP., FXD, CER DI:0.001UF, 20%, 200V	56289	40C73A5
C68	283-0175-00			CAP., FXD, CER DI:10PF, 5%, 200V	72982	8101B210C0G0100J
C73	283-0121-00			CAP., FXD, CER DI:0.001UF, 20%, 200V	56289	40C73A5
C74	283-0140-00	B010100	B079999	CAP., FXD, CER DI:4.7PF, 5%, 50V	72982	8101E003A479C
C74	283-0141-00	B080000		CAP., FXD, CER DI:200PF, 10%, 600V	14193	PD-0321-201K
C78	283-0072-01			CAP., FXD, CER DI:0.01UF, +80-20%, 200V	51642	S-300-200Z5V103M
C81	283-0182-00			CAP., FXD, CER DI:51PF, 5%, 400V	72982	8121N400A510J
C86	283-0121-00			CAP., FXD, CER DI:0.001UF, 20%, 200V	56289	40C73A5
C91	283-0121-00			CAP., FXD, CER DI:0.001UF, 20%, 200V	56289	40C73A5
C92	283-0182-00			CAP., FXD, CER DI:51PF, 5%, 400V	72982	8121N400A510J
C93	283-0177-00			CAP., FXD, CER DI:1UF, +80-20%, 25V	56289	273C5
C97	283-0121-00			CAP., FXD, CER DI:0.001UF, 20%, 200V	56289	40C73A5
C101	285-0719-00			CAP., FXD, PLSTC:0.015UF, 5%, 100V	84411	663UW-15351
C104	283-0177-00			CAP., FXD, CER DI:1UF, +80-20%, 25V	56289	273C5
C106	283-0051-00			CAP., FXD, CER DI:0.0033UF, 5%, 100V	72982	8131N145COG0332J
C108	283-0154-00			CAP., FXD, CER DI:22PF, 5%, 50V	72982	8111B061COG220J
C111	283-0115-00			CAP., FXD, CER DI:47PF, 5%, 200V	59660	805-519-COG0470J
C114	283-0060-00			CAP., FXD, CER DI:100PF, 5%, 200V	72982	855-535U2J101J
C122	283-0121-00			CAP., FXD, CER DI:0.001UF, 20%, 200V	56289	40C73A5
C124	283-0121-00			CAP., FXD, CER DI:0.001UF, 20%, 200V	56289	40C73A5
C127	283-0072-01			CAP., FXD, CER DI:0.01UF, +80-20%, 200V	51642	S-300-200Z5V103M
C129	290-0135-00			CAP., FXD, ELCTLT:15UF, 20%, 20V	56289	150D156X0020B2
C131	283-0201-00	XB050000		CAP., FXD, CER DI:27PF, 10%, 200V	72982	8101B210X7R0270K
C133	283-0175-00			CAP., FXD, CER DI:10PF, 5%, 200V	72982	8101B210C0G0100J
C134	283-0197-00			CAP., FXD, CER DI:470PF, 5%, 100V	72982	8121N075COG0471J
C137	283-0072-01			CAP., FXD, CER DI:0.01UF, +80-20%, 200V	51642	S-300-200Z5V103M
C140	283-0182-00	XB180000		CAP., FXD, CER DI:51PF, 5%, 400V	72982	8121N400A510J
C141	283-0175-00			CAP., FXD, CER DI:10PF, 5%, 200V	72982	8101B210C0G0100J
C144	283-0077-00			CAP., FXD, CER DI:330PF, 5%, 500V	59660	831-500B331J
C163	283-0060-00			CAP., FXD, CER DI:100PF, 5%, 200V	72982	855-535U2J101J
C171	283-0186-00			CAP., FXD, CER DI:27PF, 5%, 50V	59660	811A058COG0270J
C178	283-0175-00			CAP., FXD, CER DI:10PF, 5%, 200V	72982	8101B210C0G0100J
C182	283-0115-00			CAP., FXD, CER DI:47PF, 5%, 200V	59660	805-519-COG0470J
C186	283-0186-00			CAP., FXD, CER DI:27PF, 5%, 50V	59660	811A058COG0270J
C187	283-0175-00			CAP., FXD, CER DI:10PF, 5%, 200V	72982	8101B210C0G0100J
C191	283-0030-00			CAP., FXD, CER DI:0.015UF, 2.5KV	72982	3903BW41225U153Z
C810	290-0114-00	XB050000		CAP., FXD, ELCTLT:47UF, 20%, 6V	56289	150D476X0006B2

Replaceable Electrical Parts—7T11

Ckt No.	Tektronix Part No.	Serial/Model No. Eff	Dscont	Name & Description	Mfr Code	Mfr Part Number
C811	283-0072-01			CAP., FXD, CER DI:0.01UF, +80-20%, 200V	51642	S-300-200Z5V103M
C812	290-0135-00			CAP., FXD, ELCTLT:15UF, 20%, 20V	56289	150D156X0020B2
C813	283-0204-00			CAP., FXD, CER DI:0.01UF, 20%, 50V	72982	8121N061Z5U0103M
C814	290-0135-00			CAP., FXD, ELCTLT:15UF, 20%, 20V	56289	150D156X0020B2
C815	290-0135-00	B010100	B019999	CAP., FXD, ELCTLT:15UF, 20%, 20V	56289	150D156X0020B2
C815	290-0296-00	B020000		CAP., FXD, ELCTLT:100UF, 20%, 20V	56289	150D107X0020S2
C816	283-0072-01			CAP., FXD, CER DI:0.01UF, +80-20%, 200V	51642	S-300-200Z5V103M
C817	283-0072-01			CAP., FXD, CER DI:0.01UF, +80-20%, 200V	51642	S-300-200Z5V103M
C818	283-0121-00			CAP., FXD, CER DI:0.001UF, 20%, 200V	56289	40C73A5
C819	283-0204-00	XB050000		CAP., FXD, CER DI:0.01UF, 20%, 50V	72982	8121N061Z5U0103M
CR26	152-0141-02			SEMICON D DEVICE:SILICON, 30V, 150MA	01295	1N4152R
CR28	152-0329-00			SEMICON D DEVICE:TUNNEL, 21MA, 1.5PF	80009	152-0329-00
CR29	152-0140-01			SEMICON D DEVICE:TUNNEL, 8PF, 10MA	03508	SMTD995
CR32	152-0141-02	XB020000		SEMICON D DEVICE:SILICON, 30V, 150MA	01295	1N4152R
CR43	152-0246-00			SEMICON D DEVICE:SW, SI, 40V, 200MA	03508	DE140
CR44	152-0246-00			SEMICON D DEVICE:SW, SI, 40V, 200MA	03508	DE140
CR51	152-0141-02			SEMICON D DEVICE:SILICON, 30V, 150MA	01295	1N4152R
CR63	152-0322-00			SEMICON D DEVICE:SILICON, 15V, HOT CARRIER	50434	5082-2672
CR73	152-0322-00			SEMICON D DEVICE:SILICON, 15V, HOT CARRIER	50434	5082-2672
CR91	152-0141-02			SEMICON D DEVICE:SILICON, 30V, 150MA	01295	1N4152R
CR92	152-0322-00			SEMICON D DEVICE:SILICON, 15V, HOT CARRIER	50434	5082-2672
CR95	152-0322-00			SEMICON D DEVICE:SILICON, 15V, HOT CARRIER	50434	5082-2672
CR96	152-0322-00			SEMICON D DEVICE:SILICON, 15V, HOT CARRIER	50434	5082-2672
CR103	152-0141-02			SEMICON D DEVICE:SILICON, 30V, 150MA	01295	1N4152R
CR105	152-0141-02			SEMICON D DEVICE:SILICON, 30V, 150MA	01295	1N4152R
CR106	152-0141-02			SEMICON D DEVICE:SILICON, 30V, 150MA	01295	1N4152R
CR107	152-0141-02			SEMICON D DEVICE:SILICON, 30V, 150MA	01295	1N4152R
CR109	152-0141-02			SEMICON D DEVICE:SILICON, 30V, 150MA	01295	1N4152R
CR115	152-0141-02			SEMICON D DEVICE:SILICON, 30V, 150MA	01295	1N4152R
CR131	152-0141-02			SEMICON D DEVICE:SILICON, 30V, 150MA	01295	1N4152R
CR132	152-0071-00			SEMICON D DEVICE:GERMANIUM, 15V, 40MA	15238	G865
CR134	152-0177-00			SEMICON D DEVICE:TUNNEL, 10MA, 4PF	80009	152-0177-00
CR142	152-0140-01			SEMICON D DEVICE:TUNNEL, 8PF, 10MA	03508	SMTD995
CR149	152-0141-02			SEMICON D DEVICE:SILICON, 30V, 150MA	01295	1N4152R
CR152	152-0177-00			SEMICON D DEVICE:TUNNEL, 10MA, 4PF	80009	152-0177-00
CR172	152-0141-02			SEMICON D DEVICE:SILICON, 30V, 150MA	01295	1N4152R
CR181	152-0141-02			SEMICON D DEVICE:SILICON, 30V, 150MA	01295	1N4152R
CR185	152-0141-02			SEMICON D DEVICE:SILICON, 30V, 150MA	01295	1N4152R
CR191	152-0141-02			SEMICON D DEVICE:SILICON, 30V, 150MA	01295	1N4152R
DS136	150-0048-00			LAMP, INCAND:5V, 60MA	08806	683
J11	131-0265-00			CONNECTOR, RCPT, :RIGHT ANGLE MOUNT	98291	51-053-0000
J31	131-0265-00			CONNECTOR, RCPT, :RIGHT ANGLE MOUNT	98291	51-053-0000
J33	131-0265-00			CONNECTOR, RCPT, :RIGHT ANGLE MOUNT	98291	51-053-0000
J162	131-0265-00			CONNECTOR, RCPT, :RIGHT ANGLE MOUNT	98291	51-053-0000
J189	131-0265-00			CONNECTOR, RCPT, :RIGHT ANGLE MOUNT	98291	51-053-0000
K30	108-0599-00			COIL, REED SW:6VDC, SINGLE REED	80009	108-0599-00
K30-S1	260-1002-00	B010100	B129999	SWITCH, REED: SPST, 28V	54208	0330019
K30-S1	260-1237-00	B130000		SWITCH, REED: SPST	95348	MR-455-MODIFIED
K31	108-0599-00			COIL, REED SW:6VDC, SINGLE REED	80009	108-0599-00
K31-S1	260-1002-00	B010100	B129999	SWITCH, REED: SPST, 28V	54208	0330019
K31-S1	260-1237-00	B130000		SWITCH, REED: SPST	95348	MR-455-MODIFIED
K32	108-0599-00			COIL, REED SW:6VDC, SINGLE REED	80009	108-0599-00
K32-S1	260-1002-00	B010100	B129999	SWITCH, REED: SPST, 28V	54208	0330019
K32-S1	260-1237-00	B130000		SWITCH, REED: SPST	95348	MR-455-MODIFIED
K70	108-0599-00			COIL, REED SW:6VDC, SINGLE REED	80009	108-0599-00
K70-S1	260-1002-00	B010100	B129999	SWITCH, REED: SPST, 28V	54208	0330019

Replaceable Electrical Parts—7T11

Ckt No.	Tektronix Part No.	Serial/Model No. Eff	Dscont	Name & Description	Mfr Code	Mfr Part Number
K70-S1	260-1237-00	B130000		SWITCH, REED: SPST	95348	MR-455-MODIFIED
K71	108-0599-00			COIL, REED SW: 6VDC, SINGLE REED	80009	108-0599-00
K71-S1	260-1002-00	B010100	B129999	SWITCH, REED: SPST, 28V	54208	0330019
K71-S1	260-1237-00	B130000		SWITCH, REED: SPST	95348	MR-455-MODIFIED
K80	108-0599-00			COIL, REED SW: 6VDC, SINGLE REED	80009	108-0599-00
K80-S1	260-0721-00			SWITCH, REED: SPDT, 35A	12617	MRH-DT
L33	108-0262-00			COIL, RF: FIXED, 510NH	80009	108-0262-00
L36	276-0543-00	XB222995		SHLD BEAD, ELEK: FERRITE	80009	276-0543-00
L38	276-0543-00	XB222995		SHLD BEAD, ELEK: FERRITE	80009	276-0543-00
L129	120-0382-00			XFMR, TOROID: 14 TURNS, SINGLE	80009	120-0382-00
L188	276-0543-00			SHLD BEAD, ELEK: FERRITE	80009	276-0543-00
L189	276-0543-00			SHLD BEAD, ELEK: FERRITE	80009	276-0543-00
L812	120-0382-00	B010100	B109999X	XFMR, TOROID: 14 TURNS, SINGLE	80009	120-0382-00
L814	120-0382-00			XFMR, TOROID: 14 TURNS, SINGLE	80009	120-0382-00
L815	120-0382-00			XFMR, TOROID: 14 TURNS, SINGLE	80009	120-0382-00
Q12	151-0190-00			TRANSISTOR: SILICON, NPN	07263	S032677
Q22	151-0190-00	B010100	B049999	TRANSISTOR: SILICON, NPN	07263	S032677
Q22	151-0302-00	B050000		TRANSISTOR: SILICON, NPN	07263	S038487
Q26	151-0188-00			TRANSISTOR: SILICON, PNP	04713	SPS6868K
Q32	151-0190-00			TRANSISTOR: SILICON, NPN	07263	S032677
Q36	151-0202-00			TRANSISTOR: SILICON, PNP	80009	151-0202-00
Q38	151-0202-00			TRANSISTOR: SILICON, PNP	80009	151-0202-00
Q44	151-1011-01			TRANSISTOR: SILICON, JFE, N-CHANNEL, DUAL	22229	FD1167
Q50	151-0202-00			TRANSISTOR: SILICON, PNP	80009	151-0202-00
Q62	151-0212-00	B010100	B019999	TRANSISTOR: SILICON, NPN	04713	SRF 518
Q72	151-0212-00	B010100	B019999	TRANSISTOR: SILICON, NPN	04713	SRF 518
Q62	153-0591-00	B020000		SEMICON DVC SE: MATCHED PAIR	80009	153-0591-00
Q72						
Q82	151-0268-00			TRANSISTOR: SILICON, NPN, DUAL	80009	151-0268-00
Q92	151-0202-00			TRANSISTOR: SILICON, PNP	80009	151-0202-00
Q102	151-0190-00			TRANSISTOR: SILICON, NPN	07263	S032677
Q104	151-0220-00			TRANSISTOR: SILICON, PNP	07263	S036228
Q122	151-0202-00			TRANSISTOR: SILICON, PNP	80009	151-0202-00
Q128	151-0212-00			TRANSISTOR: SILICON, NPN	04713	SRF 518
Q136	151-0207-00			TRANSISTOR: SILICON, NPN	03508	X32D6191
Q138	151-0188-00			TRANSISTOR: SILICON, PNP	04713	SPS6868K
Q140	151-0267-00	B010100	B179999	TRANSISTOR: SILICON, NPN	80009	151-0267-00
Q140	151-0268-00	B180000		TRANSISTOR: SILICON, NPN, DUAL	80009	151-0268-00
Q144	151-0220-00			TRANSISTOR: SILICON, PNP	07263	S036228
Q146	151-0220-00			TRANSISTOR: SILICON, PNP	07263	S036228
Q154	151-0220-00			TRANSISTOR: SILICON, PNP	07263	S036228
Q156	151-0220-00			TRANSISTOR: SILICON, PNP	07263	S036228
Q162	151-0269-00	B010100	B179999	TRANSISTOR: SILICON, NPN, SEL FROM SE3005	07263	FMT5092
Q162	151-0441-00	B180000		TRANSISTOR: SILICON, NPN	04713	SRF501
Q164	151-0269-00	B010100	B179999	TRANSISTOR: SILICON, NPN, SEL FROM SE3005	07263	FMT5092
Q164	151-0441-00	B180000		TRANSISTOR: SILICON, NPN	04713	SRF501
Q174	151-0190-00			TRANSISTOR: SILICON, NPN	07263	S032677
Q184	151-0271-00			TRANSISTOR: SILICON, PNP	04713	SPS8236
Q186	151-0269-00	B010100	B179999	TRANSISTOR: SILICON, NPN, SEL FROM SE3005	07263	FMT5092
Q186	151-0441-00	B180000		TRANSISTOR: SILICON, NPN	04713	SRF501
Q194	151-1005-00			TRANSISTOR: SILICON, JFE, N-CHANNEL	80009	151-1005-00
Q196	151-0207-00			TRANSISTOR: SILICON, NPN	03508	X32D6191
R10	311-0836-00	B010100	B109999	RES., VAR, NONWIR: TRMR, 5K OHM, 0.5W	01121	SV5021
R10	311-1267-00	B110000		RES., VAR, NONWIR: 5K OHM, 10%, 0.50W	32997	3329P-L58-502
R11	317-0242-00			RES., FXD, CMPSN: 2.4K OHM, 5%, 0.125W	01121	BB2425
R12	317-0152-00			RES., FXD, CMPSN: 1.5K OHM, 5%, 0.125W	01121	BB1525

Replaceable Electrical Parts—7T11

Ckt No.	Tektronix Part No.	Serial/Model No. Eff	Dscont	Name & Description	Mfr Code	Mfr Part Number
R13	301-0820-00			RES., FXD, CMPSN: 82 OHM, 5%, 0.50W	01121	EB8205
R14	317-0047-00			RES., FXD, CMPSN: 4.7 OHM, 5%, 0.125W	01121	BB47G5
R16	317-0752-00			RES., FXD, CMPSN: 7.5K OHM, 5%, 0.125W	01121	BB7525
R17	317-0203-00			RES., FXD, CMPSN: 20K OHM, 5%, 0.125W	01121	BB2035
R18	317-0153-00			RES., FXD, CMPSN: 15K OHM, 5%, 0.125W	01121	BB1535
R21	301-0470-00			RES., FXD, CMPSN: 47 OHM, 5%, 0.50W	01121	EB4705
R25	317-0471-00			RES., FXD, CMPSN: 470 OHM, 5%, 0.125W	01121	BB4715
R26	317-0472-00			RES., FXD, CMPSN: 4.7K OHM, 5%, 0.125W	01121	BB4725
R27	317-0203-00			RES., FXD, CMPSN: 20K OHM, 5%, 0.125W	01121	BB2035
R28	317-0471-00			RES., FXD, CMPSN: 470 OHM, 5%, 0.125W	01121	BB4715
R30	311-0884-00	B010100	B109999	RES., VAR, NONWIR: TRMR, 100 OHM, 0.5W	01121	SV1011
R30	311-1259-00	B110000		RES., VAR, NONWIR: 100 OHM, 10%, 0.50W	32997	3329P-L58-101
R31	301-0101-00	B010100	B019999	RES., FXD, CMPSN: 100 OHM, 5%, 0.50W	01121	EB1015
R31	301-0750-00	B020000		RES., FXD, CMPSN: 75 OHM, 5%, 0.50W	01121	EB7505
R32	317-0102-00			RES., FXD, CMPSN: 1K OHM, 5%, 0.125W	01121	BB1025
R33	317-0047-00			RES., FXD, CMPSN: 4.7 OHM, 5%, 0.125W	01121	BB47G5
R34	317-0470-00			RES., FXD, CMPSN: 47 OHM, 5%, 0.125W	01121	BB4705
R35	317-0390-00			RES., FXD, CMPSN: 39 OHM, 5%, 0.125W	01121	BB3905
R36	317-0390-00			RES., FXD, CMPSN: 39 OHM, 5%, 0.125W	01121	BB3905
R37	317-0510-00	B010100	B019999	RES., FXD, CMPSN: 51 OHM, 5%, 0.125W	01121	BB5105
R37	317-0151-00	B020000		RES., FXD, CMPSN: 150 OHM, 5%, 0.125W	01121	BB1515
R38	315-0222-00			RES., FXD, CMPSN: 2.2K OHM, 5%, 0.25W	01121	CB2225
R39	317-0361-00			RES., FXD, CMPSN: 360 OHM, 5%, 0.125W	01121	BB3615
R41	317-0271-00			RES., FXD, CMPSN: 270 OHM, 5%, 0.125W	01121	BB2715
R42	321-0481-00			RES., FXD, FILM: 1M OHM, 1%, 0.125W	24546	NA4D1004F
R43	317-0474-00			RES., FXD, CMPSN: 470K OHM, 5%, 0.125W	01121	BB4745
R45	311-0607-00			RES., VAR, NONWIR: 10K OHM, 10%, 0.50W	73138	82-25-2
R46	317-0203-00			RES., FXD, CMPSN: 20K OHM, 5%, 0.125W	01121	BB2035
R47	323-0303-00			RES., FXD, FILM: 14K OHM, 1%, 0.50W	75042	CECTO-1402F
R48	317-0101-00			RES., FXD, CMPSN: 100 OHM, 5%, 0.125W	01121	BB1015
R51	317-0101-00			RES., FXD, CMPSN: 100 OHM, 5%, 0.125W	01121	BB1015
R53	317-0821-00			RES., FXD, CMPSN: 820 OHM, 5%, 0.125W	01121	BB8215
R56	317-0512-00			RES., FXD, CMPSN: 5.1K OHM, 5%, 0.125	01121	BB5125
R61	317-0510-00			RES., FXD, CMPSN: 51 OHM, 5%, 0.125W	01121	BB5105
R62	317-0510-00			RES., FXD, CMPSN: 51 OHM, 5%, 0.125W	01121	BB5105
R64	317-0390-00	B010100	B079999	RES., FXD, CMPSN: 39 OHM, 5%, 0.125W	01121	BB3905
R64	317-0101-00	B080000		RES., FXD, CMPSN: 100 OHM, 5%, 0.125W	01121	BB1015
R65	321-0237-00			RES., FXD, FILM: 2.87K OHM, 1%, 0.125W	91637	MFF1816G28700F
R68	317-0510-00			RES., FXD, CMPSN: 51 OHM, 5%, 0.125W	01121	BB5105
R69	315-0430-00			RES., FXD, CMPSN: 43 OHM, 5%, 0.25W	01121	CB4305
R72	317-0510-00			RES., FXD, CMPSN: 51 OHM, 5%, 0.125W	01121	BB5105
R75	321-0237-00			RES., FXD, FILM: 2.87K OHM, 1%, 0.125W	91637	MFF1816G28700F
R76	315-0152-00	XB080000		RES., FXD, CMPSN: 1.5K OHM, 5%, 0.25W	01121	CB1525
R77	317-0510-00			RES., FXD, CMPSN: 51 OHM, 5%, 0.125W	01121	BB5105
R78	317-0103-00			RES., FXD, CMPSN: 10K OHM, 5%, 0.125W	01121	BB1035
R79	317-0303-00			RES., FXD, CMPSN: 30K OHM, 5%, 0.125W	01121	BB3035
R80	311-0831-00	B010100	B109999	RES., VAR, NONWIR: TRMR, 100K OHM, 0.5W	73138	91-104-0
R80	311-1272-00	B110000		RES., VAR, NONWIR: 100K OHM, 10%, 0.50W	32997	3329P-L58-104
R81	317-0511-00			RES., FXD, CMPSN: 510 OHM, 5%, 0.125W	01121	BB5115
R83	317-0154-00			RES., FXD, CMPSN: 150K OHM, 5%, 0.125	01121	BB1545
R84	317-0223-00			RES., FXD, CMPSN: 22K OHM, 5%, 0.125W	01121	BB2235
R85	317-0511-00			RES., FXD, CMPSN: 510 OHM, 5%, 0.125W	01121	BB5115
R86	317-0101-00			RES., FXD, CMPSN: 100 OHM, 5%, 0.125W	01121	BB1015
R87	317-0562-00			RES., FXD, CMPSN: 5.6K OHM, 5%, 0.125	01121	BB5625
R88	317-0362-00			RES., FXD, CMPSN: 3.6K OHM, 5%, 0.125W	01121	BB3625
R91	317-0100-00			RES., FXD, CMPSN: 10 OHM, 5%, 0.125W	01121	BB1005
R92	317-0680-00	XB222995		RES., FXD, CMPSN: 68 OHM, 5%, 0.125W	01121	BB6805

Ckt No.	Tektronix Part No.	Serial/Model No. Eff	Dscont	Name & Description	Mfr Code	Mfr Part Number
R93	317-0101-00			RES., FXD, CMPSN: 100 OHM, 5%, 0.125W	01121	BB1015
R94	317-0821-00			RES., FXD, CMPSN: 820 OHM, 5%, 0.125W	01121	BB8215
R96	317-0472-00			RES., FXD, CMPSN: 4.7K OHM, 5%, 0.125W	01121	BB4725
R97	317-0101-00			RES., FXD, CMPSN: 100 OHM, 5%, 0.125W	01121	BB1015
R103	315-0202-00			RES., FXD, CMPSN: 2K OHM, 5%, 0.25W	01121	CB2025
R104	317-0433-00			RES., FXD, CMPSN: 43K OHM, 5%, 0.125W	01121	BB4335
R105	317-0912-00			RES., FXD, CMPSN: 9.1K OHM, 5%, 0.125W	01121	BB9125
R108	317-0101-00			RES., FXD, CMPSN: 100 OHM, 5%, 0.125W	01121	BB1015
R109	317-0912-00			RES., FXD, CMPSN: 9.1K OHM, 5%, 0.125W	01121	BB9125
R111	317-0682-00			RES., FXD, CMPSN: 6.8K OHM, 5%, 0.125W	01121	BB6825
R113	317-0432-00			RES., FXD, CMPSN: 4.3K OHM, 5%, 0.125W	01121	BB4325
R114	317-0182-00			RES., FXD, CMPSN: 1.8K OHM, 5%, 0.125W	01121	BB1825
R116	317-0242-00			RES., FXD, CMPSN: 2.4K OHM, 5%, 0.125W	01121	BB2425
R117	317-0153-00			RES., FXD, CMPSN: 15K OHM, 5%, 0.125W	01121	BB1535
R118	317-0472-00			RES., FXD, CMPSN: 4.7K OHM, 5%, 0.125W	01121	BB4725
R120	311-0732-00	B010100	B109999	RES., VAR, NONWIR: TRMR, 1K OHM, 0.5W	01121	SV1021
R120	311-1263-00	B110000		RES., VAR, NONWIR: 1K OHM, 10%, 0.50W	32997	3329P-L58-102
R121	308-0292-00			RES., FXD, WW: 2.2K OHM, 5%, 3W	91637	CW2B-22000J
R122	317-0512-00			RES., FXD, CMPSN: 5.1K OHM, 5%, 0.125	01121	BB5125
R123	317-0202-00			RES., FXD, CMPSN: 2K OHM, 5%, 0.125W	01121	BB2025
R124	317-0511-00			RES., FXD, CMPSN: 510 OHM, 5%, 0.125W	01121	BB5115
R125	321-0233-00			RES., FXD, FILM: 2.61K OHM, 1%, 0.125W	91637	MFF1816G26100F
R126	321-0155-00			RES., FXD, FILM: 402 OHM, 1%, 0.125W	91637	MFF1816G402ROF
R127	317-0101-00			RES., FXD, CMPSN: 100 OHM, 5%, 0.125W	01121	BB1015
R128	321-0226-00			RES., FXD, FILM: 2.21K OHM, 1%, 0.125W	91637	MFF1816G22100F
R129	317-0100-00			RES., FXD, CMPSN: 10 OHM, 5%, 0.125W	01121	BB1005
R130	317-0510-00			RES., FXD, CMPSN: 510 OHM, 5%, 0.125W	01121	BB5105
R131	317-0472-00			RES., FXD, CMPSN: 4.7K OHM, 5%, 0.125W	01121	BB4725
R132	317-0680-00			RES., FXD, CMPSN: 68 OHM, 5%, 0.125W	01121	BB6805
R133	317-0430-00			RES., FXD, CMPSN: 43 OHM, 5%, 0.125W	01121	BB4305
R134	321-0275-00			RES., FXD, FILM: 7.15K OHM, 1%, 0.125W	91637	MFF1816G71500F
R135	311-0634-00			RES., VAR, NONWIR: TRMR, 500 OHM, 0.5W	32997	3326H-G48-501
R136	307-0230-00			PHOTOELECTRIC C: 6900A PEAK	03911	CL1352
R137	317-0432-00			RES., FXD, CMPSN: 4.3K OHM, 5%, 0.125W	01121	BB4325
R138	321-0210-00			RES., FXD, FILM: 1.5K OHM, 1%, 0.125W	91637	MFF1816G15000F
R139	317-0100-00			RES., FXD, CMPSN: 10 OHM, 5%, 0.125W	01121	BB1005
R140	317-0303-00			RES., FXD, CMPSN: 30K OHM, 5%, 0.125W	01121	BB3035
R141	316-0150-00	XB180000	B222994	RES., FXD, CMPSN: 15 OHM, 10%, 0.25W	01121	CB1501
R141	317-0100-00	B222995		RES., FXD, CMPSN: 10 OHM, 5%, 0.125W	01121	BB1005
R143	317-0181-00			RES., FXD, CMPSN: 180 OHM, 5%, 0.125W	01121	BB1815
R144	317-0102-00			RES., FXD, CMPSN: 1K OHM, 5%, 0.125W	01121	BB1025
R145	311-0704-00	B010100	B109999	RES., VAR, NONWIR: TRMR, 500 OHM, 0.5W	73138	91-101-0
R145	311-1261-00	B110000		RES., VAR, NONWIR: 500 OHM, 10%, 0.50W	32997	3329P-L58-501
R146	323-0204-00			RES., FXD, FILM: 1.3K OHM, 1%, 0.50W	75042	CECT0-1301F
R147	317-0271-00			RES., FXD, CMPSN: 270 OHM, 5%, 0.125W	01121	BB2715
R148	317-0151-00			RES., FXD, CMPSN: 150 OHM, 5%, 0.125W	01121	BB1515
R149	317-0153-00			RES., FXD, CMPSN: 15K OHM, 5%, 0.125W	01121	BB1535
R151	317-0510-00			RES., FXD, CMPSN: 51 OHM, 5%, 0.125W	01121	BB5105
R152	317-0910-00			RES., FXD, CMPSN: 91 OHM, 5%, 0.125W	01121	BB9105
R154	317-0102-00			RES., FXD, CMPSN: 1K OHM, 5%, 0.125W	01121	BB1025
R155	311-0732-00	B010100	B109999	RES., VAR, NONWIR: TRMR, 1K OHM, 0.5W	01121	SV1021
R155	311-1263-00	B110000		RES., VAR, NONWIR: 1K OHM, 10%, 0.50W	32997	3329P-L58-102
R156	323-0212-00			RES., FXD, FILM: 1.58 OHM, 1%, 0.50W	75042	CECT0-1581F
R157	317-0271-00			RES., FXD, CMPSN: 270 OHM, 5%, 0.125W	01121	BB2715
R158	317-0151-00			RES., FXD, CMPSN: 150 OHM, 5%, 0.125W	01121	BB1515
R159	317-0202-00			RES., FXD, CMPSN: 2K OHM, 5%, 0.125W	01121	BB2025
R161	317-0101-00			RES., FXD, CMPSN: 100 OHM, 5%, 0.125W	01121	BB1015

Replaceable Electrical Parts—7T11

Ckt No.	Tektronix Part No.	Serial/Model No. Eff	Dscont	Name & Description	Mfr Code	Mfr Part Number
R163	315-0822-00			RES., FXD, CMPSN: 8.2K OHM, 5%, 0.25W	01121	CB8225
R164	317-0153-00			RES., FXD, CMPSN: 15K OHM, 5%, 0.125W	01121	BB1535
R165	317-0271-00			RES., FXD, CMPSN: 270 OHM, 5%, 0.125W	01121	BB2715
R167	317-0182-00			RES., FXD, CMPSN: 1.8K OHM, 5%, 0.125W	01121	BB1825
R171	317-0622-00			RES., FXD, CMPSN: 6.2K OHM, 5%, 0.125W	01121	BB6225
R172	317-0303-00			RES., FXD, CMPSN: 30K OHM, 5%, 0.125W	01121	BB3035
R174	317-0162-00			RES., FXD, CMPSN: 1.6K OHM, 5%, 0.125	01121	BB1625
R176	301-0912-00			RES., FXD, CMPSN: 9.1K OHM, 5%, 0.50W	01121	EB9125
R178	317-0203-00			RES., FXD, CMPSN: 20K OHM, 5%, 0.125W	01121	BB2035
R182	317-0103-00			RES., FXD, CMPSN: 10K OHM, 5%, 0.125W	01121	BB1035
R184	317-0751-00			RES., FXD, CMPSN: 750 OHM, 5%, 0.125W	01121	BB7515
R185	317-0102-00			RES., FXD, CMPSN: 1K OHM, 5%, 0.125W	01121	BB1025
R186	317-0751-00			RES., FXD, CMPSN: 750 OHM, 5%, 0.125W	01121	BB7515
R187	317-0330-00			RES., FXD, CMPSN: 33 OHM, 5%, 0.125W	01121	BB3305
R188	315-0132-00			RES., FXD, CMPSN: 1.3K OHM, 5%, 0.25W	01121	CB1325
R191	317-0102-00			RES., FXD, CMPSN: 1K OHM, 5%, 0.125W	01121	BB1025
R192	317-0107-00			RES., FXD, CMPSN: 100M OHM, 5%, 0.125W	01121	BB1075
R194	317-0153-00			RES., FXD, CMPSN: 15K OHM, 5%, 0.125W	01121	BB1535
R811	317-0101-00			RES., FXD, CMPSN: 100 OHM, 5%, 0.125W	01121	BB1015
R812	131-0566-00	XB110000		BUS CONDUCTOR: DUMMY RES, 2.375, 22 AWG	55210	L-2007-1
R817	317-0101-00			RES., FXD, CMPSN: 100 OHM, 5%, 0.125W	01121	BB1015
R818	317-0101-00			RES., FXD, CMPSN: 100 OHM, 5%, 0.125W	01121	BB1015
U20	156-0053-00			MICROCIRCUIT, LI: VOLTAGE REGULATOR	07263	SL21721
U110	156-0030-00			MICROCIRCUIT, DI: QUAD 2-INPUT NAND GATE	01295	SN7400(N OR J)
VR104	152-0395-00			SEMICOND DEVICE: ZENER, 0.4W, 4.3V, 5%	14552	TD332317
VR107	152-0395-00			SEMICOND DEVICE: ZENER, 0.4W, 4.3V, 5%	14552	TD332317

Replaceable Electrical Parts—7T11

Ckt No.	Tektronix Part No.	Serial/Model No. Eff	Dscont	Name & Description	Mfr Code	Mfr Part Number
	670-1121-00	B010100	B029999	CKT BOARD ASSY:INTERFACE	80009	670-1121-00
	670-1121-01	B030000	B079999	CKT BOARD ASSY:INTERFACE	80009	670-1121-01
	670-1121-02	B080000	B099999	CKT BOARD ASSY:INTERFACE	80009	670-1121-02
	670-1121-04	B100000		CKT BOARD ASSY:INTERFACE	80009	670-1121-04
C100A	290-0267-00			CAP., FXD, ELCTLT: 1UF, 20%, 35V	56289	162D105X0035CD2
C100B	290-0188-00			CAP., FXD, ELCTLT: 0.1UF, 10%, 35V	56289	162D104X9035BC2
C100C	283-0239-00			CAP., FXD, CER DI: 0.022UF, 10%, 50V	72982	8121N083X7R0223K
C290A-E	295-0127-00			CAP. SET, MATCHED: 0.5, 0.05, 0.00495UF, 450PF	80009	295-0127-00
C318A-C	295-0128-00			CAP. SET, MATCHED: 3.05UF, 0.00495UF, 450PF	80009	295-0128-00
C318D	SELECTED			(ADDED IF NECESSARY)		
C802	290-0135-00			CAP., FXD, ELCTLT: 15UF, 20%, 20V	56289	150D156X0020B2
C803	290-0114-00			CAP., FXD, ELCTLT: 47UF, 20%, 6V	56289	150D476X0006B2
C804	290-0135-00			CAP., FXD, ELCTLT: 15UF, 20%, 20V	56289	150D156X0020B2
C822	290-0135-00			CAP., FXD, ELCTLT: 15UF, 20%, 20V	56289	150D156X0020B2
C825	290-0135-00			CAP., FXD, ELCTLT: 15UF, 20%, 20V	56289	150D156X0020B2
L802	120-0382-00			XFMR, TOROID: 14 TURNS, SINGLE	80009	120-0382-00
L803	120-0382-00			XFMR, TOROID: 14 TURNS, SINGLE	80009	120-0382-00
L804	120-0382-00			XFMR, TOROID: 14 TURNS, SINGLE	80009	120-0382-00
R317	317-0510-00	XB080000		RES., FXD, CMPSN: 51 OHM, 5%, 0.125W	01121	BB5105
R318	317-0101-00			RES., FXD, CMPSN: 100 OHM, 5%, 0.125W	01121	BB1015
R530A, B	311-1018-00			RES., VAR, NONWIR: PNL, 2 X 20K OHM, 0.5W	01121	G07632
R580A	321-0293-00			RES., FXD, FILM: 11K OHM, 1%, 0.125W	91637	MFF1816G11001F
R580B	321-0381-00			RES., FXD, FILM: 90.9K OHM, 1%, 0.125W	91637	MFF1816G90901F
R580C	321-0289-00			RES., FXD, FILM: 10K OHM, 1%, 0.125W	91637	MFF1816G10001F
R580D	321-0481-00			RES., FXD, FILM: 1M OHM, 1%, 0.125W	24546	NA4D1004F
R648	317-0104-00	B010100	B029999	RES., FXD, CMPSN: 100K OHM, 5%, 0.125W	01121	BB1045
R648	315-0203-00	B030000		RES., FXD, CMPSN: 20K OHM, 5%, 0.25W	01121	CB2035
R649	321-0289-00	B010100	B029999	RES., FXD, FILM: 10K OHM, 1%, 0.125W	91637	MFF1816G10001F
R649	315-0102-00	B030000		RES., FXD, CMPSN: 1K OHM, 5%, 0.25W	01121	CB1025
R678	315-0153-00			RES., FXD, CMPSN: 15K OHM, 5%, 0.25W	01121	CB1535
R681	315-0331-00	B010100	B019999	RES., FXD, CMPSN: 330 OHM, 5%, 0.25W	01121	CB3315
R681	315-0271-00	B020000		RES., FXD, CMPSN: 270 OHM, 5%, 0.25W	01121	CB2715
R685	316-0102-00	XB100000		RES., FXD, CMPSN: 1K OHM, 10%, 0.25W	01121	CB1021
R741	321-0402-00			RES., FXD, FILM: 150K OHM, 1%, 0.125W	24546	NA55D1503F
R742	321-0373-00			RES., FXD, FILM: 75K OHM, 1%, 0.125W	91637	MFF1816G75001F
R744	321-0373-00			RES., FXD, FILM: 75K OHM, 1%, 0.125W	91637	MFF1816G75001F
R745	321-0402-00			RES., FXD, FILM: 150K OHM, 1%, 0.125W	24546	NA55D1503F
R747	321-0373-00			RES., FXD, FILM: 75K OHM, 1%, 0.125W	91637	MFF1816G75001F
R748	321-0402-00			RES., FXD, FILM: 150K OHM, 1%, 0.125W	24546	NA55D1503F
R751	321-0402-00			RES., FXD, FILM: 150K OHM, 1%, 0.125W	24546	NA55D1503F
R752	321-0373-00			RES., FXD, FILM: 75K OHM, 1%, 0.125W	91637	MFF1816G75001F
R754	321-0402-00			RES., FXD, FILM: 150K OHM, 1%, 0.125W	24546	NA55D1503F
R755	321-0344-00			RES., FXD, FILM: 37.4K OHM, 1%, 0.125W	91637	MFF1816G37401F
R756	321-0373-00			RES., FXD, FILM: 75K OHM, 1%, 0.125W	91637	MFF1816G75001F
R759	315-0753-00			RES., FXD, CMPSN: 75K OHM, 5%, 0.25W	01121	CB7535
R761	321-0373-00			RES., FXD, FILM: 75K OHM, 1%, 0.125W	91637	MFF1816G75001F
R762	321-0402-00			RES., FXD, FILM: 150K OHM, 1%, 0.125W	24546	NA55D1503F
R764	321-0356-00			RES., FXD, FILM: 49.9K OHM, 1%, 0.125W	91637	MFF1816G49901F
R765	321-0344-00			RES., FXD, FILM: 37.4K OHM, 1%, 0.125W	91637	MFF1816G37401F
R766	321-0335-00			RES., FXD, FILM: 30.1K OHM, 1%, 0.125W	91637	MFF1816G30101F
R771	301-0472-00			RES., FXD, CMPSN: 4.7K OHM, 5%, 0.50W	01121	EB4725
S530A	670-1121-00	B010100	B029999	CKT BOARD ASSY:INTERFACE	80009	670-1121-00
	-----			(SEE RMPL FOR REPLACEMENT PARTS)		
S530A	670-1121-01	B030000	B079999	CKT BOARD ASSY:INTERFACE	80009	670-1121-01
	-----			(SEE RMPL FOR REPLACEMENT PARTS)		
S530A	670-1121-02	B080000	B089999	CKT BOARD ASSY:INTERFACE	80009	670-1121-02
	-----			(SEE RMPL FOR REPLACEMENT PARTS)		

Replaceable Electrical Parts—7T11

Ckt No.	Tektronix Part No.	Serial/Model No. Eff	Dscont	Name & Description	Mfr Code	Mfr Part Number
S530A	105-0329-00 -----	B090000		ACTR ASSY,CAM S:TIME/CM (SEE RMPL FOR REPLACEMENT PARTS)	80009	105-0329-00
S530B	670-1121-00 -----	B010100	B029999	CKT BOARD ASSY:INTERFACE (SEE RMPL FOR REPLACEMENT PARTS)	80009	670-1121-00
S530B	670-1121-01 -----	B030000	B079999	CKT BOARD ASSY:INTERFACE (SEE RMPL FOR REPLACEMENT PARTS)	80009	670-1121-01
S530B	670-1121-02 -----	B080000	B089999	CKT BOARD ASSY:INTERFACE (SEE RMPL FOR REPLACEMENT PARTS)	80009	670-1121-02
S530B	105-0330-00 -----	B090000		ACTR ASSY,CAM S:SWEEP RANGE (SEE RMPL FOR REPLACEMENT PARTS)	80009	105-0330-00
S531A-C	670-1121-00 -----	B010100	B029999	CKT BOARD ASSY:INTERFACE (SEE RMPL FOR REPLACEMENT PARTS)	80009	670-1121-00
S531A-C	670-1121-01 -----	B030000	B079999	CKT BOARD ASSY:INTERFACE (SEE RMPL FOR REPLACEMENT PARTS)	80009	670-1121-01
S531A-C	670-1121-02 -----	B080000	B099999	CKT BOARD ASSY:INTERFACE (SEE RMPL FOR REPLACEMENT PARTS)	80009	670-1121-02
S531A-C	670-1121-04 -----	B100000		CKT BOARD ASSY:INTERFACE (SEE RMPL FOR REPLACEMENT PARTS)	80009	670-1121-04

Replaceable Electrical Parts—7T11

Ckt No.	Tektronix Part No.	Serial/Model No. Eff	Dscont	Name & Description	Mfr Code	Mfr Part Number
	670-1195-00 670-1195-01	B010100 B020000	B019999	CKT BOARD ASSY:TRIGGER AMPLIFIER SW CKT BOARD ASSY:TRIGGER AMPLIFIER SW	80009 80009	670-1195-00 670-1195-01
DS80 DS80	150-0057-01 150-0048-01	B010100 B020000	B019999	LAMP, INCAND:5V,0.115A,WIRE LD,SEL LAMP, INCAND:5V,0.06A,SEL	76854 08806	17AS15 683AS15
S80	670-1195-00 -----	B010100	B019999	CKT BOARD ASSY:TRIGGER AMPLIFIER SW (SEE RMPL FOR REPLACEMENT PARTS)	80009	670-1195-00
S80	670-1195-01 -----	B020000		CKT BOARD ASSY:TRIGGER AMPLIFIER SW (SEE RMPL FOR REPLACEMENT PARTS)	80009	670-1195-01
	670-1196-00 670-1196-01	B010100 B020000	B019999	CKT BOARD ASSY:TRIGGER SOURCE SW CKT BOARD ASSY:TRIGGER SOURCE SW	80009 80009	670-1196-00 670-1196-01
DS30 DS30	150-0057-01 150-0048-01	B010100 B020000	B019999	LAMP, INCAND:5V,0.115A,WIRE LD,SEL LAMP, INCAND:5V,0.06A,SEL	76854 08806	17AS15 683AS15
R30	317-0102-00			RES., FXD, CMPSN:1K OHM, 5%, 0.125W	01121	BB1025
S30	670-1196-00 -----	B010100	B019999	CKT BOARD ASSY:TRIGGER SOURCE SW (SEE RMPL FOR REPLACEMENT PARTS)	80009	670-1196-00
S30	670-1196-01 -----	B020000		CKT BOARD ASSY:TRIGGER SOURCE SW (SEE RMPL FOR REPLACEMENT PARTS)	80009	670-1196-01
	670-1197-00 670-1197-01	B010100 B020000	B019999	CKT BOARD ASSY:SCAN SW CKT BOARD ASSY:SCAN SW	80009 80009	670-1197-00 670-1197-01
CR609	152-0141-02			SEMICOND DEVICE:SILICON, 30V, 150MA	01295	1N4152R
DS610 DS610	150-0057-01 150-0048-01	B010100 B020000	B019999	LAMP, INCAND:5V,0.115A,WIRE LD,SEL LAMP, INCAND:5V,0.06A,SEL	76854 08806	17AS15 683AS15
R609	317-0103-00			RES., FXD, CMPSN:10K OHM, 5%, 0.125W	01121	BB1035
S610	670-1197-00 -----	B010100	B019999	CKT BOARD ASSY:SCAN SW (SEE RMPL FOR REPLACEMENT PARTS)	80009	670-1197-00
S610	670-1197-01 -----	B020000		CKT BOARD ASSY:SCAN SW (SEE RMPL FOR REPLACEMENT PARTS)	80009	670-1197-01
	670-1198-00 670-1198-01	B010100 B020000	B019999	CKT BOARD ASSY:SLOPE SW CKT BOARD ASSY:SLOPE SW	80009 80009	670-1198-00 670-1198-01
DS70 DS70	150-0057-01 150-0048-01	B010100 B020000	B019999	LAMP, INCAND:5V,0.115A,WIRE LD,SEL LAMP, INCAND:5V,0.06A,SEL	76854 08806	17AS15 683AS15
S70	670-1198-00 -----	B010100	B019999	CKT BOARD ASSY:SLOPE SW (SEE RMPL FOR REPLACEMENT PARTS)	80009	670-1198-00
S70	670-1198-01 -----	B020000		CKT BOARD ASSY:SLOPE SW (SEE RMPL FOR REPLACEMENT PARTS)	80009	670-1198-01
	670-1199-00 670-1199-01	B010100 B020000	B019999	CKT BOARD ASSY:RANDOM SEQUENCE SW CKT BOARD ASSY:RANDOM SEQUENCE SW	80009 80009	670-1199-00 670-1199-01
DS20 DS20	150-0057-01 150-0048-01	B010100 B020000	B019999	LAMP, INCAND:5V,0.115A,WIRE LD,SEL LAMP, INCAND:5V,0.06A,SEL	76854 08806	17AS15 683AS15

Replaceable Electrical Parts—7T11

Ckt No.	Tektronix Part No.	Serial/Model No. Eff	Dscont	Name & Description	Mfr Code	Mfr Part Number
R220	317-0102-00			RES.,FXD,CMPSN:1K OHM,5%,0.125W	01121	BB1025
S220	670-1199-00	B010100	B019999	CKT BOARD ASSY:RANDOM SEQUENCE SW (SEE RMPL FOR REPLACEMENT PARTS)	80009	670-1199-00
S220	670-1199-01	B020000		CKT BOARD ASSY:RANDOM SEQUENCE SW (SEE RMPL FOR REPLACEMENT PARTS)	80009	670-1199-01

Ckt No.	Tektronix Part No.	Serial/Model No. Eff	Dscont	Name & Description	Mfr Code	Mfr Part Number
CHASSIS PARTS						
C570	283-0004-00			CAP., FXD, CER DI:0.02UF, +80-20%, 150V	91418	SP203Z151-4R9
CR136	152-0141-02			SEMICONV DEVICE:SILICON, 30V, 150MA	01295	1N4152R
J10	131-0888-00			CONNECTOR, PLUG, :MALE	26805	2031-5006-95
J190	131-0579-00			CONNECTOR, RCPT, :MALE	74868	46475-1050
J569	131-0779-00			JACK, TIP:FOR 0.08 INCH DIA TEST POINT	98291	016-8010-00-0208
J610	131-0779-00			JACK, TIP:FOR 0.08 INCH DIA TEST POINT	98291	016-8010-00-0208
R70	311-1081-00			RES., VAR, NONWIR:PNL, 2 X 10K OHM, 2W	71590	BA02660XXX
R570A, B	311-0965-00			RES., VAR, NONWIR:2 X 10K OHM, 10%, 10W	80009	311-0965-00
R610	311-0467-00			RES., VAR, NONWIR:100K OHM, 20%, 0.50W	11237	300SF-41334
R679	311-0487-00			RES., VAR, NONWIR:30K OHM, 10%, 0.50W	11237	300SF-41337
R680	311-0387-00			RES., VAR, NONWIR:5K OHM, 20%	01121	W7565A

SECTION 7 DIAGRAMS AND MECHANICAL PARTS ILLUSTRATIONS

The following special symbols are used on the diagrams:

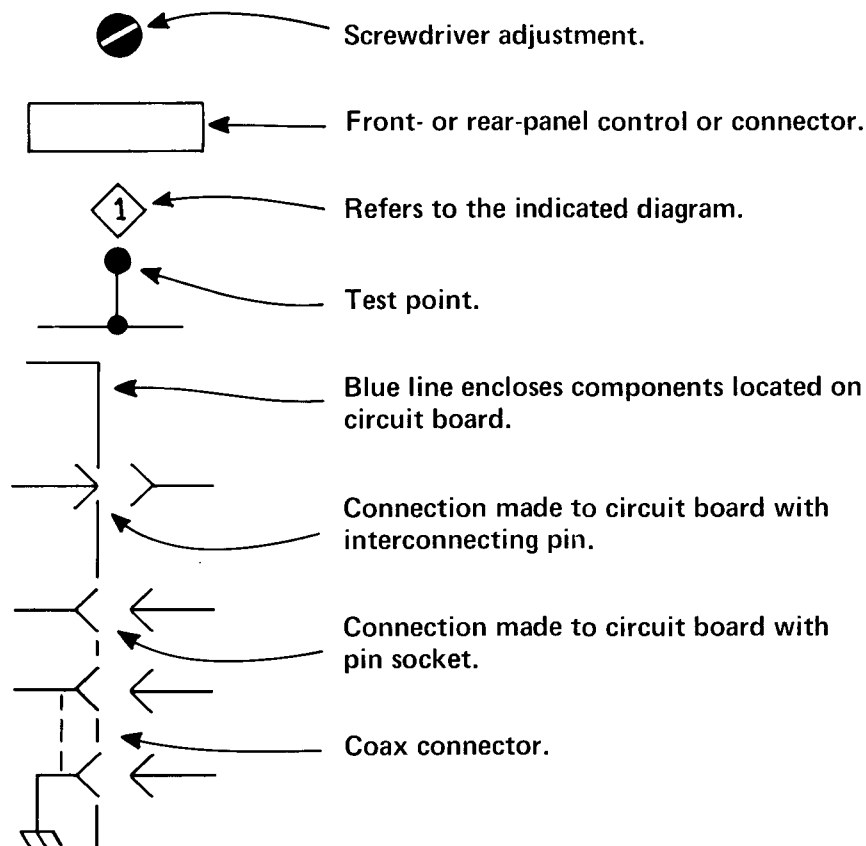

1

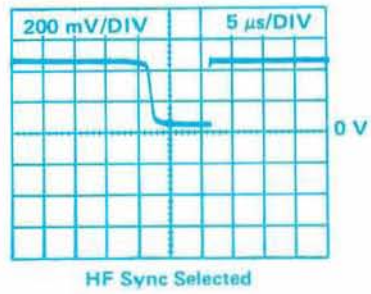

2

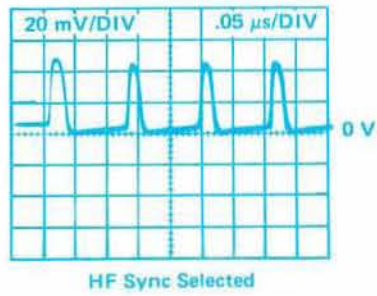

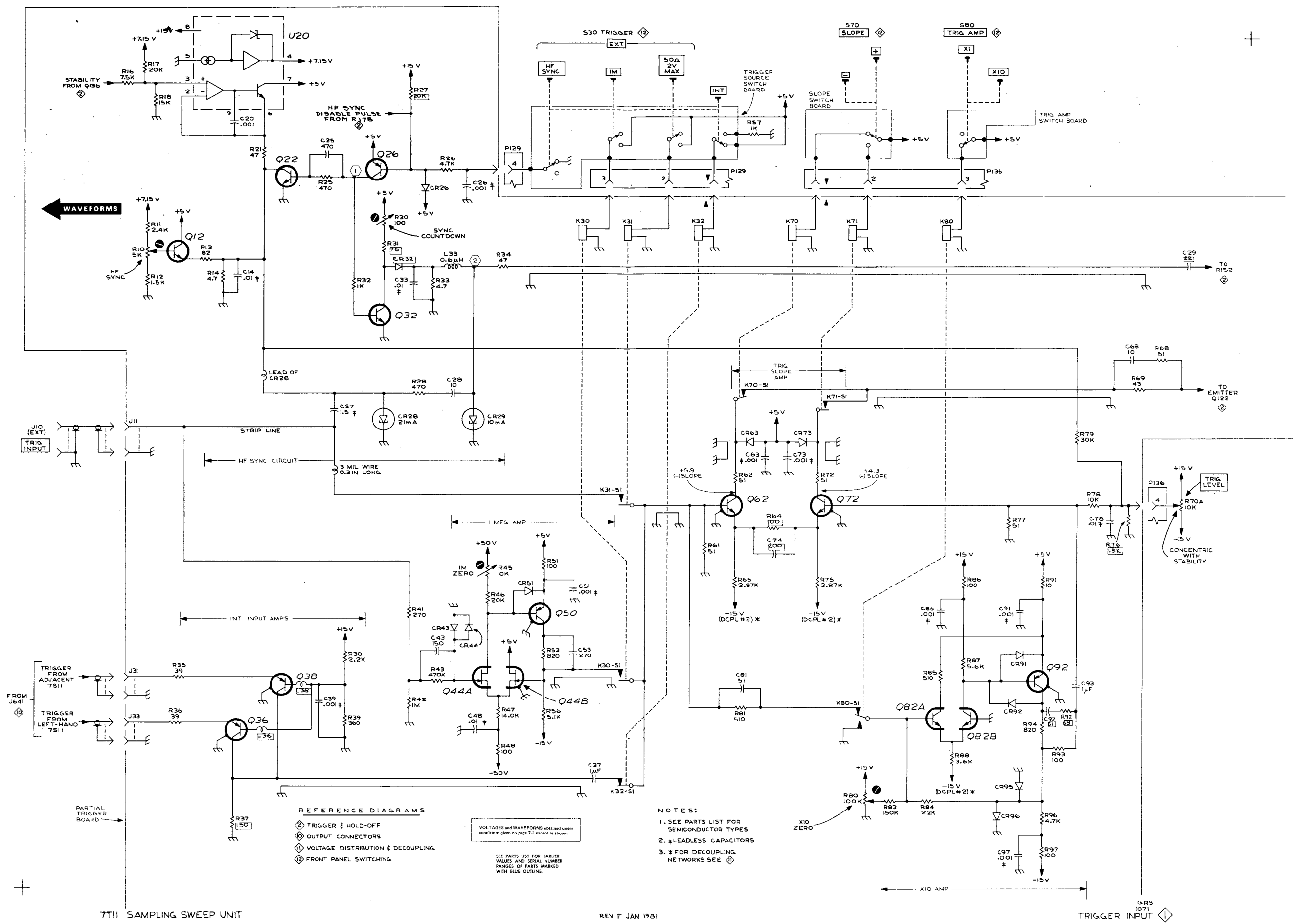

← WAVEFORMS

J10 (EXT) TRIG INPUT

FROM J641 TRIGGER FROM ADJACENT 7511 TRIGGER FROM LEFT-HAND 7511

PARTIAL TRIGGER BOARD

7711 SAMPLING SWEEP UNIT

- REFERENCE DIAGRAMS
- ⊠ TRIGGER & HOLD-OFF
 - ⊡ OUTPUT CONNECTORS
 - ⊢ VOLTAGE DISTRIBUTION & DECOUPLING
 - ⊣ FRONT PANEL SWITCHING

VOLTAGES and WAVEFORMS obtained under conditions given on page 7-2, except as shown.

SEE PARTS LIST FOR EARLIER VALUES AND SERIAL NUMBER RANGES OF PARTS MARKED WITH BLUE OUTLINE.

- NOTES:
1. SEE PARTS LIST FOR SEMICONDUCTOR TYPES
 2. ‡ LEADLESS CAPACITORS
 3. * FOR DECOUPLING NETWORKS SEE ⊠

REV F JAN 1981

TRIGGER INPUT ⊠

3

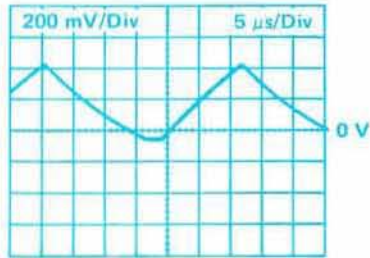

5

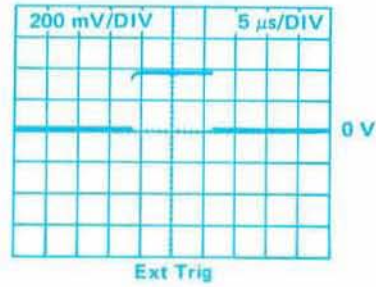

4

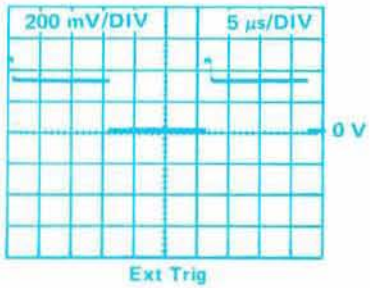

6

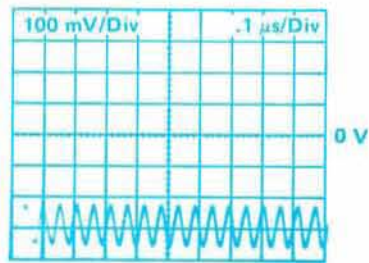

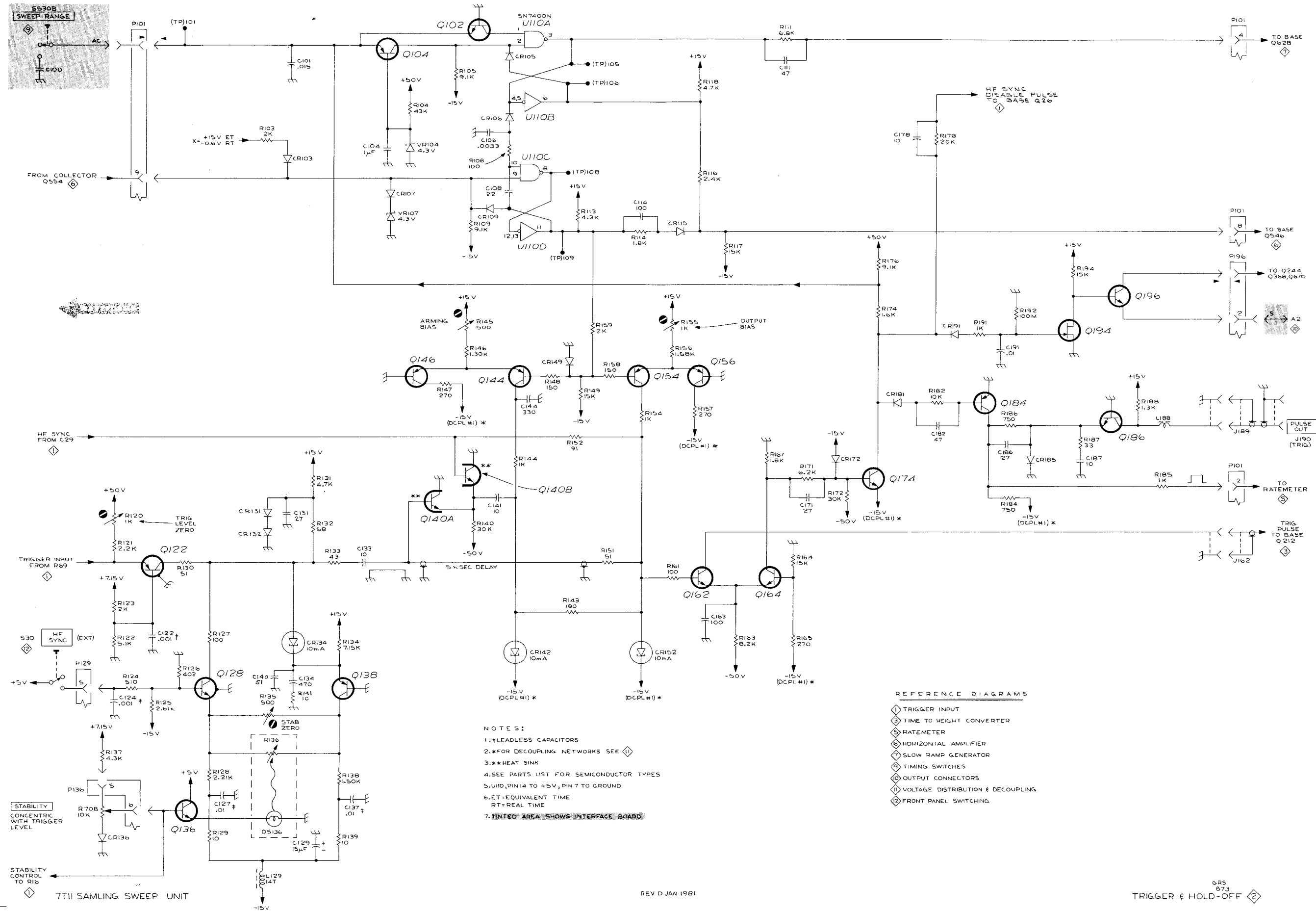

NOTES:
 1. † LEADLESS CAPACITORS
 2. * FOR DECOUPLING NETWORKS SEE Ⓛ
 3. ** HEAT SINK
 4. SEE PARTS LIST FOR SEMICONDUCTOR TYPES
 5. U110, PIN 14 TO +5V, PIN 7 TO GROUND
 6. ET = EQUIVALENT TIME
 RT = REAL TIME
 7. TINTED AREA SHOWS INTERFACE BOARD

- REFERENCE DIAGRAMS
- Ⓛ TRIGGER INPUT
 - Ⓜ TIME TO HEIGHT CONVERTER
 - Ⓝ RATEMETER
 - Ⓟ HORIZONTAL AMPLIFIER
 - Ⓡ SLOW RAMP GENERATOR
 - Ⓢ TIMING SWITCHES
 - Ⓣ OUTPUT CONNECTORS
 - Ⓤ VOLTAGE DISTRIBUTION & DECOUPLING
 - Ⓦ FRONT PANEL SWITCHING

REV D JAN 1981

6.95
 6.73
 TRIGGER & HOLD-OFF Ⓛ

TRIGGER & HOLD-OFF

2

7

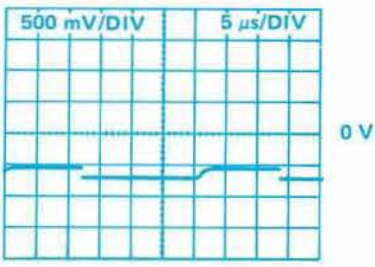

10

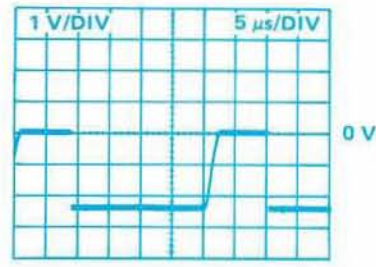

8

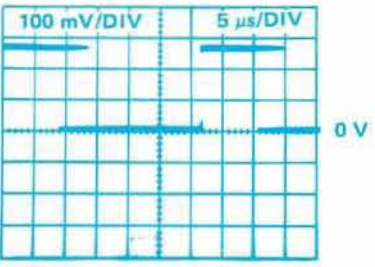

11

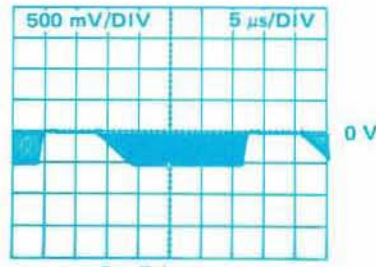

Ext Trig
Time position CW
SEQUENTIAL

9

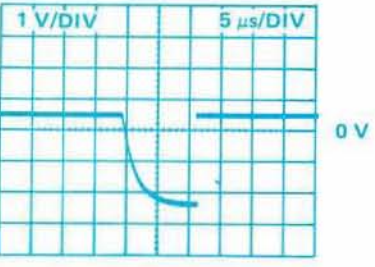

12

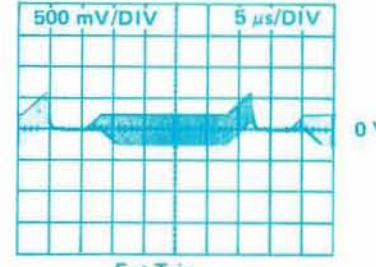

Ext Trig
Time position CW
RANDOM

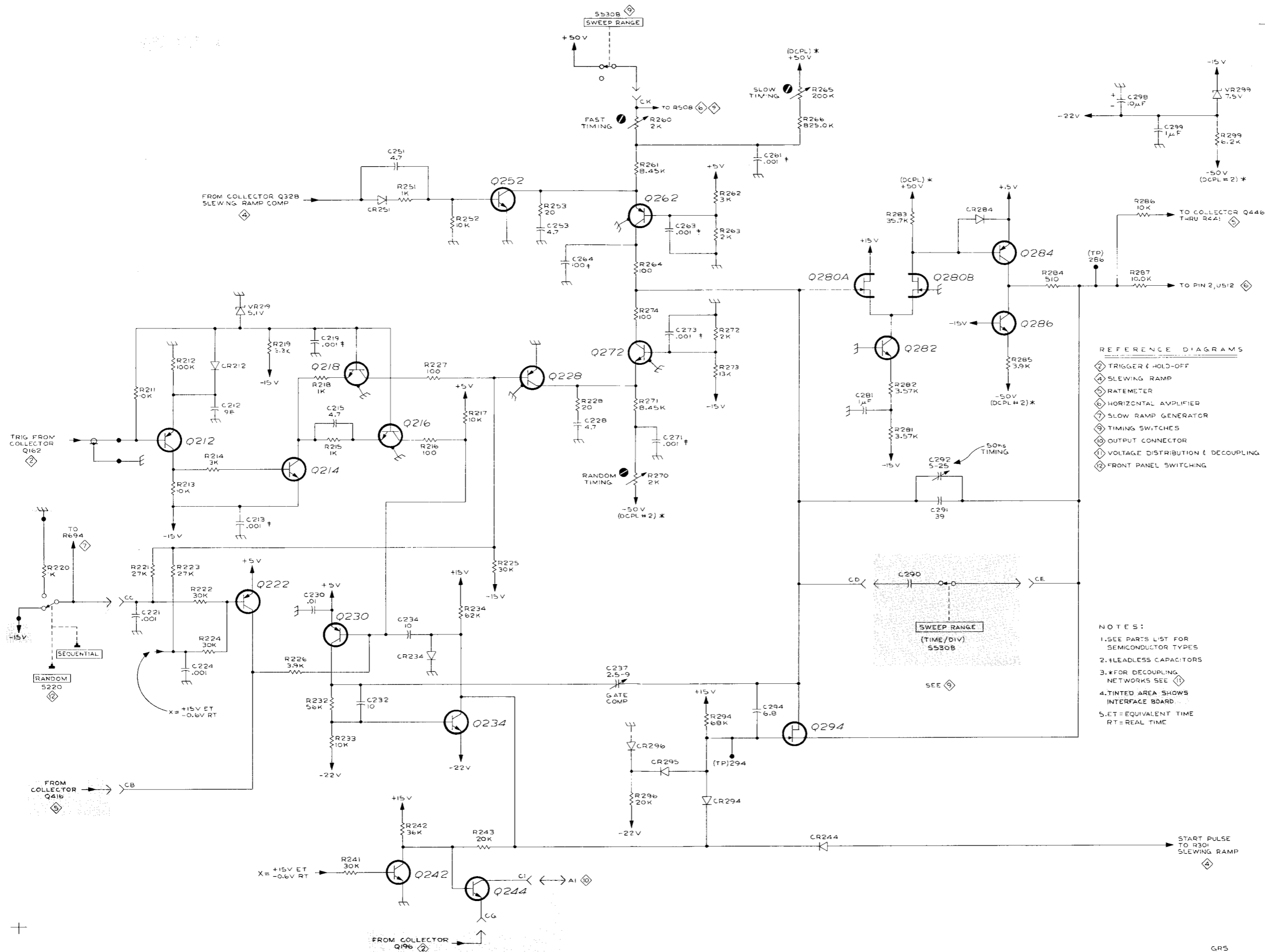

- REFERENCE DIAGRAMS
- ◇ TRIGGER & HOLD-OFF
 - ◇ SLEWING RAMP
 - ◇ RATEMETER
 - ◇ HORIZONTAL AMPLIFIER
 - ◇ SLOW RAMP GENERATOR
 - ◇ TIMING SWITCHES
 - ◇ OUTPUT CONNECTOR
 - ◇ VOLTAGE DISTRIBUTION & DECOUPLING
 - ◇ FRONT PANEL SWITCHING

- NOTES:
1. SEE PARTS LIST FOR SEMICONDUCTOR TYPES
 2. † LEADLESS CAPACITORS
 3. * FOR DECOUPLING NETWORKS SEE ◇
 4. TINTED AREA SHOWS INTERFACE BOARD
 5. ET = EQUIVALENT TIME RT = REAL TIME

TIME TO HEIGHT CONVERTER

13

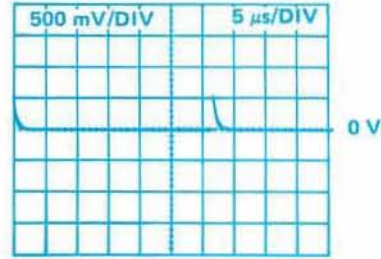
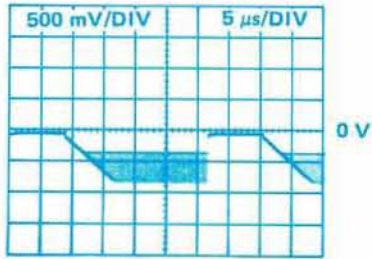

1000 Ω resistor between pins 17 & 18 of J641

FROM CR595 SLOW RAMP INVERTER

15

14

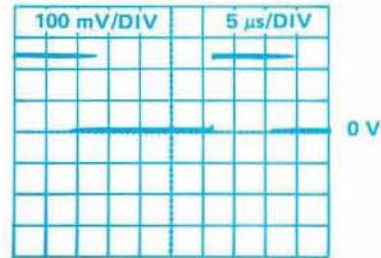
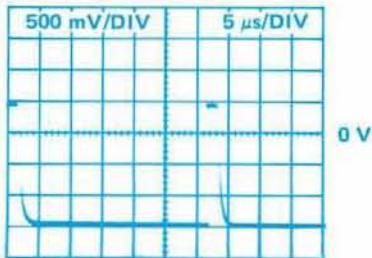

16

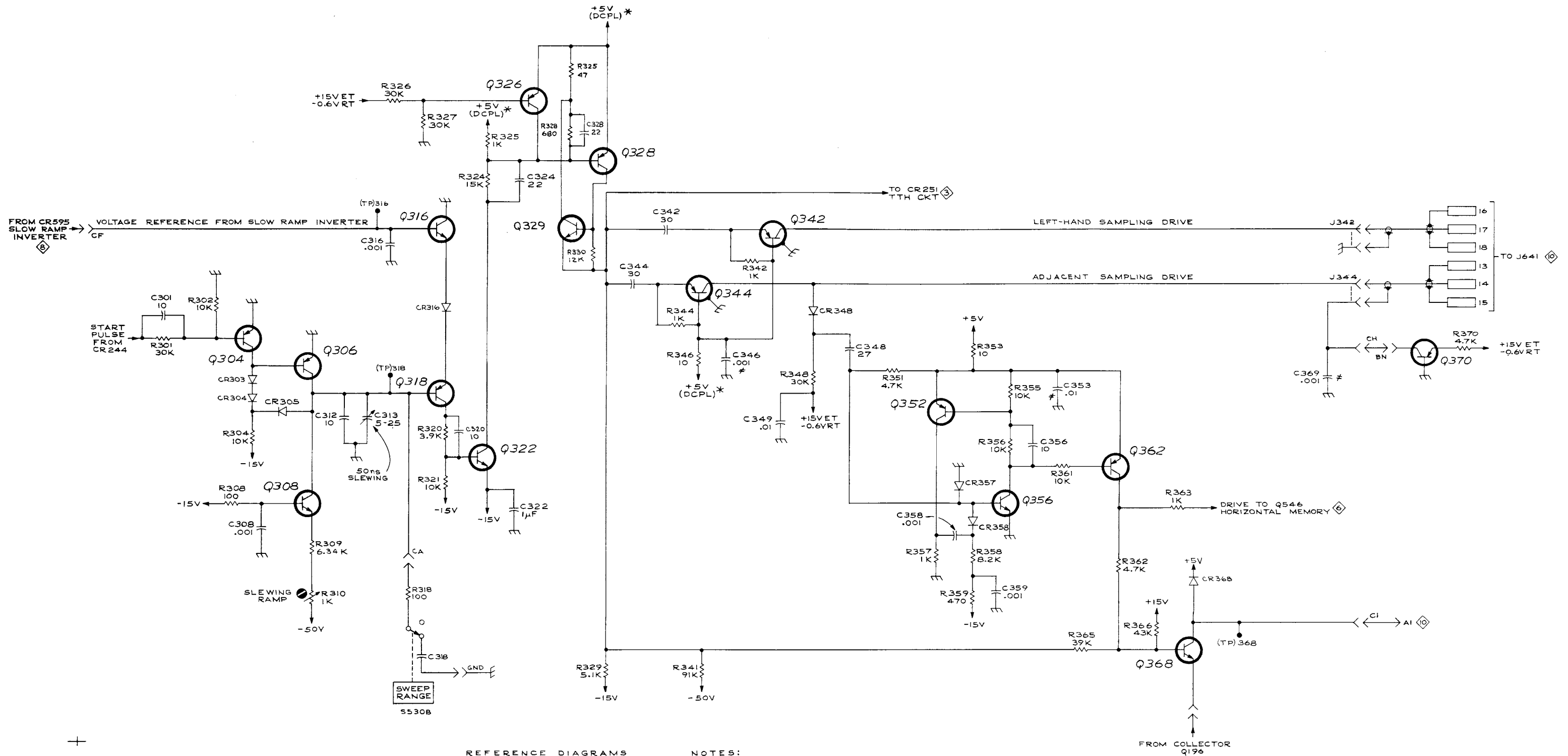

REFERENCE DIAGRAMS

- ② TRIGGER & HOLD-OFF
- ③ TIME TO HEIGHT CONVERTER
- ④ HORIZONTAL AMPLIFIER
- ⑤ OUTPUT CONNECTORS
- ⑥ VOLTAGE DISTRIBUTION & DECOUPLING

NOTES:

1. SEE PARTS LIST FOR SEMICONDUCTOR TYPES
2. # LEADLESS CAPACITOR
3. * FOR DECOUPLING NETWORKS SEE ①
4. TINTED AREAS SHOW INTERFACE BOARD

17

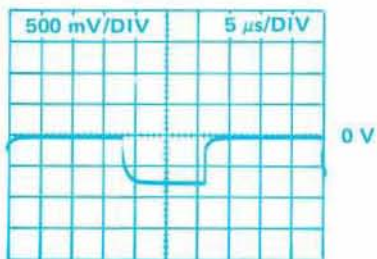

20

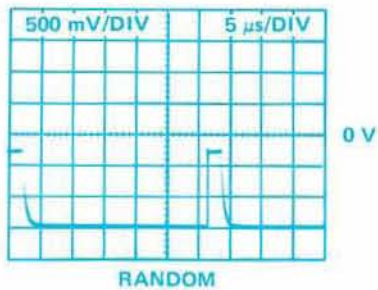

18

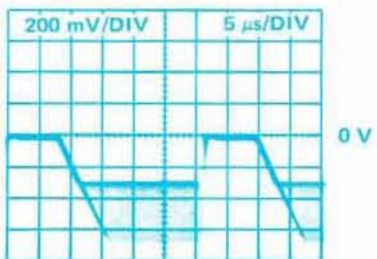

21

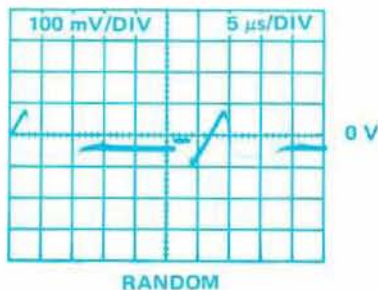

19

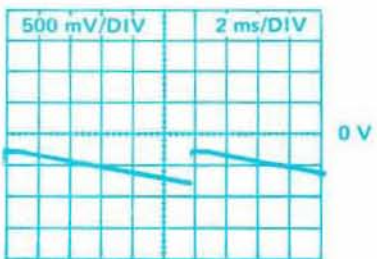

22

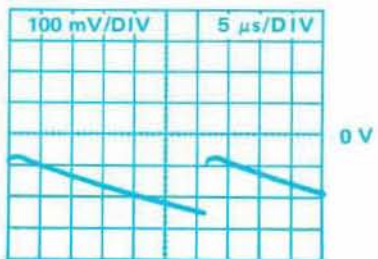

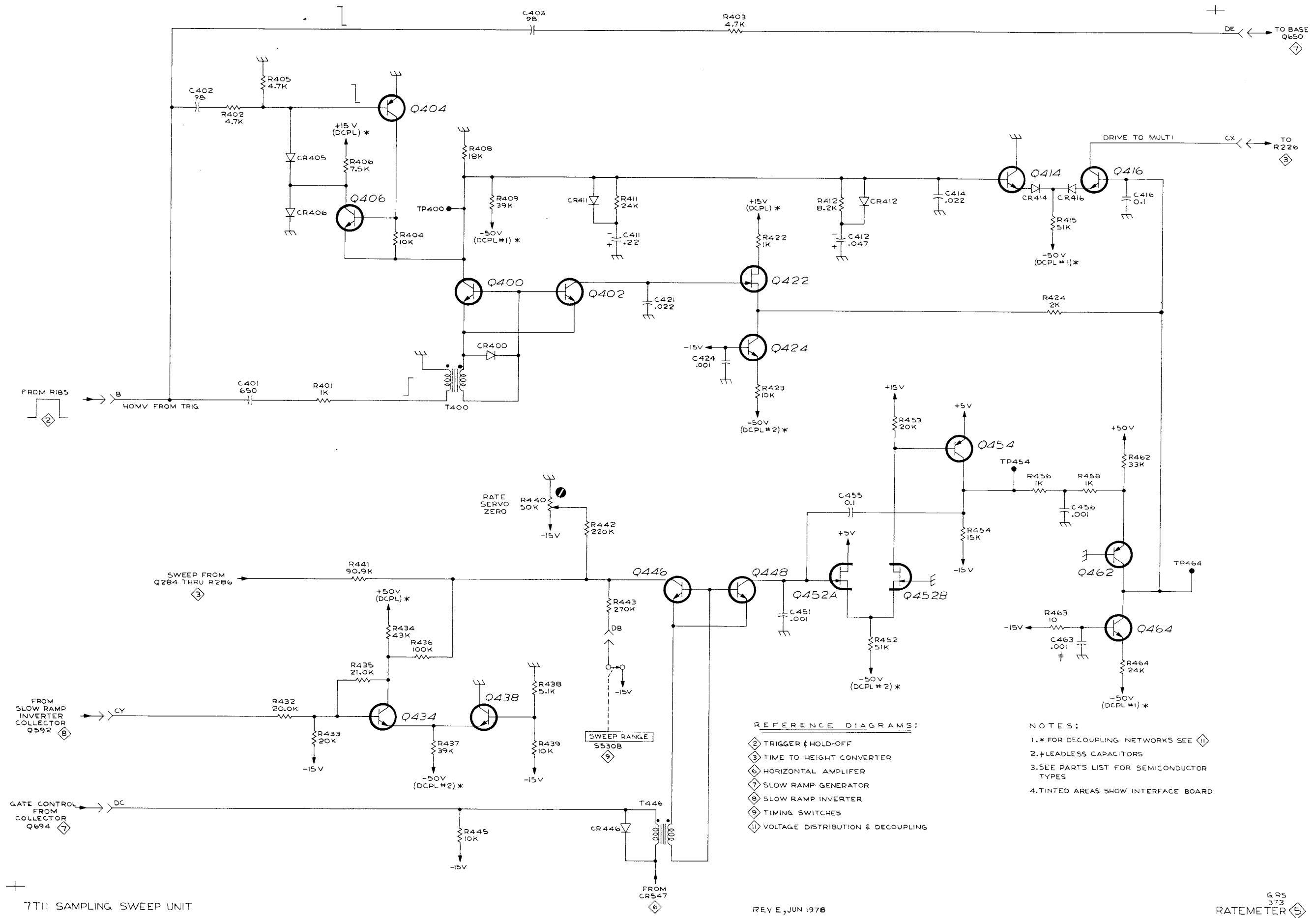

- REFERENCE DIAGRAMS:
- ② TRIGGER & HOLD-OFF
 - ③ TIME TO HEIGHT CONVERTER
 - ④ HORIZONTAL AMPLIFIER
 - ⑤ SLOW RAMP GENERATOR
 - ⑥ SLOW RAMP INVERTER
 - ⑦ TIMING SWITCHES
 - ⑧ VOLTAGE DISTRIBUTION & DECOUPLING

- NOTES:
- 1.* FOR DECOUPLING NETWORKS SEE ⑧
 - 2.≠ LEADLESS CAPACITORS
 - 3.SEE PARTS LIST FOR SEMICONDUCTOR TYPES
 - 4.TINTED AREAS SHOW INTERFACE BOARD

7T11 SAMPLING SWEEP UNIT

REV E, JUN 1978

23

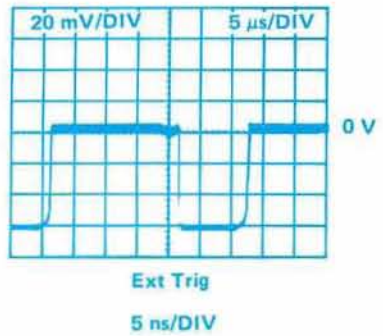

26

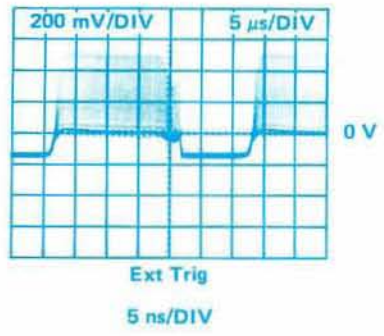

24

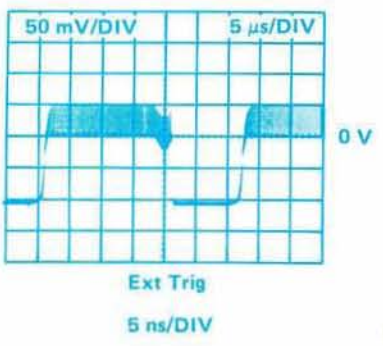

27

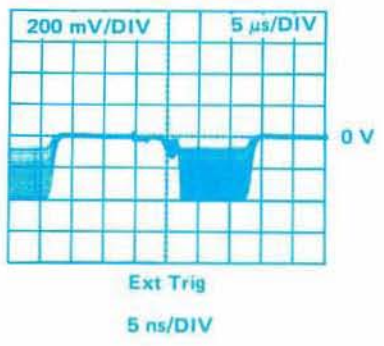

25

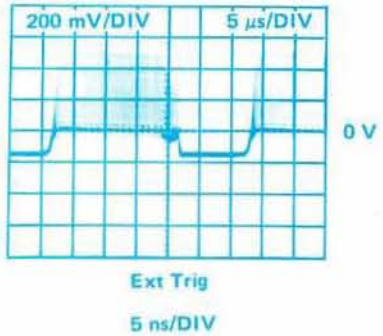

28

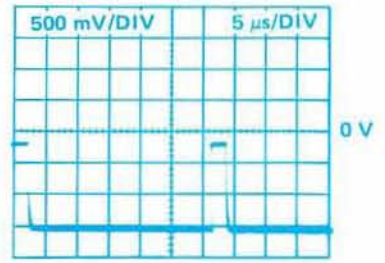

NOTES:
 1.* FOR DECOUPLING NETWORKS SEE ⑩
 2. SEE PARTS LIST FOR SEMICONDUCTOR TYPES
 3. ET = EQUIVALENT TIME
 RT = REAL TIME
 4. TINTED AREAS SHOW INTERFACE BOARD
 5. ** ADDED IF NECESSARY

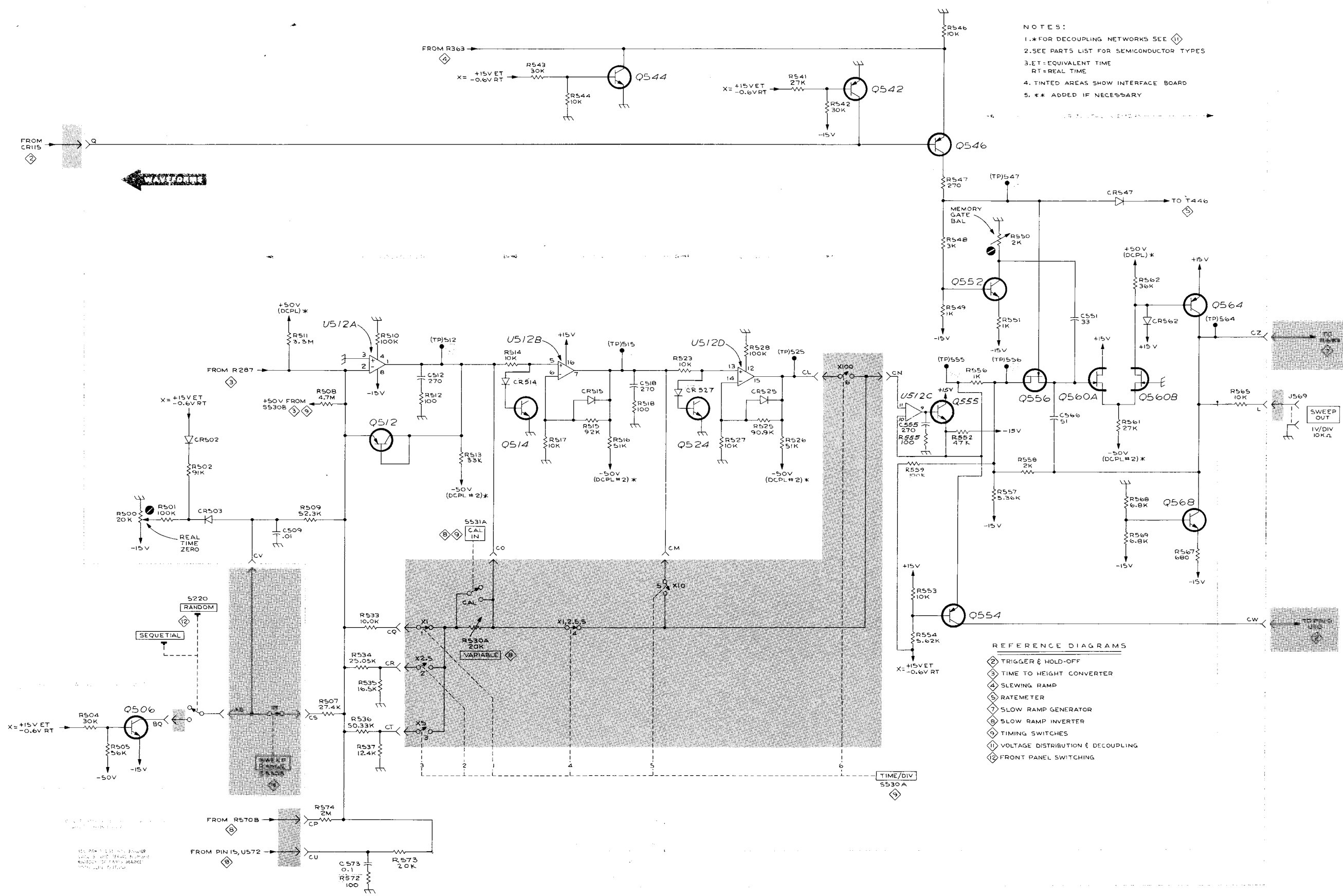

- REFERENCE DIAGRAMS
- ② TRIGGER & HOLD-OFF
 - ③ TIME TO HEIGHT CONVERTER
 - ④ SLEWING RAMP
 - ⑤ RATEMETER
 - ⑦ SLOW RAMP GENERATOR
 - ⑧ SLOW RAMP INVERTER
 - ⑨ TIMING SWITCHES
 - ⑩ VOLTAGE DISTRIBUTION & DECOUPLING
 - ⑪ FRONT PANEL SWITCHING

HORIZONTAL AMPLIFIER 6

29

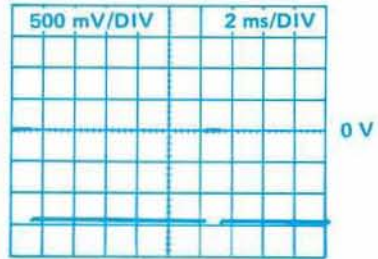

31

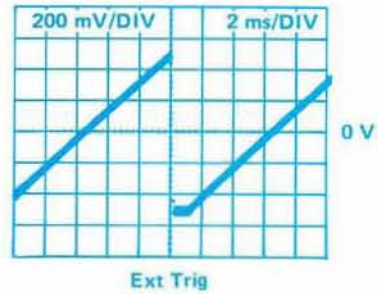

30

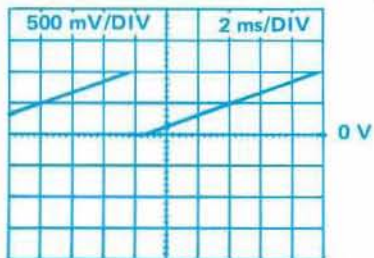

32

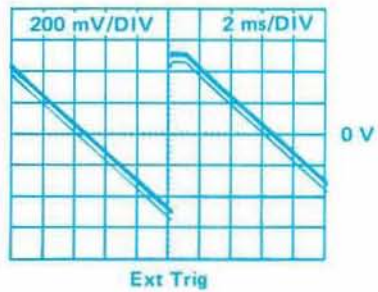

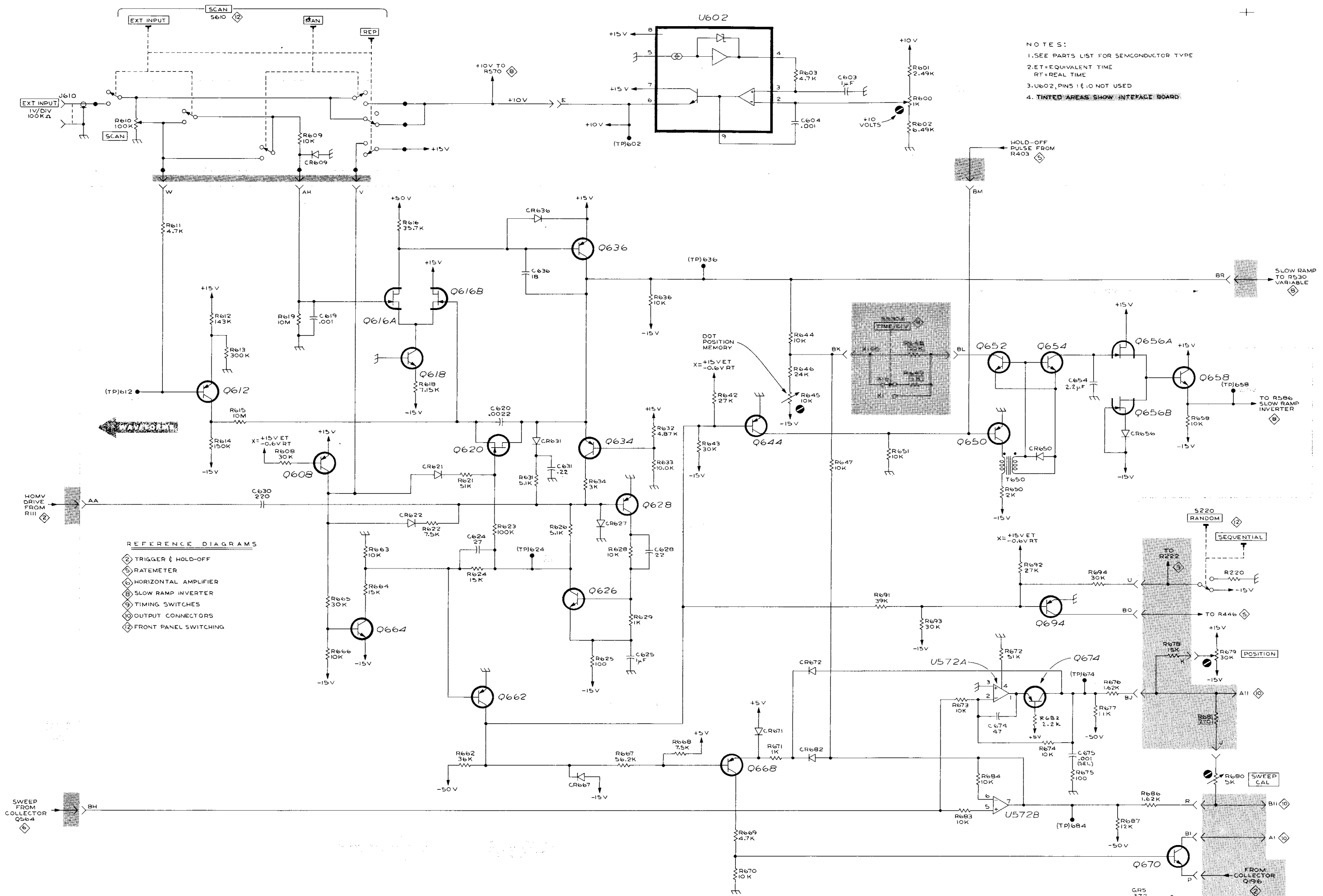

- NOTES:
1. SEE PARTS LIST FOR SEMICONDUCTOR TYPE
 2. ET = EQUIVALENT TIME
RT = REAL TIME
 3. U602, PINS 1 & 10 NOT USED
 4. TINTED AREAS SHOW INTERFACE BOARD

REFERENCE DIAGRAMS

- ② TRIGGER & HOLD-OFF
- ⑤ RATE METER
- ⑥ HORIZONTAL AMPLIFIER
- ⑧ SLOW RAMP INVERTER
- ⑩ TIMING SWITCHES
- ⑨ OUTPUT CONNECTORS
- ⑪ FRONT PANEL SWITCHING

7TII SAMPLING SWEEP UNIT

REV H JAN 1981

SLOW RAMP GENERATOR & OUTPUT AMPLIFIER

SLOW RAMP GENERATOR & OUTPUT AMPLIFIER

33

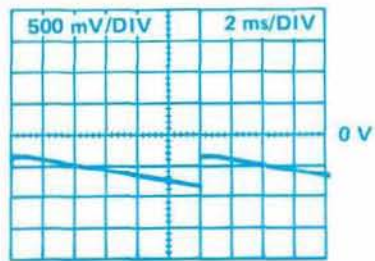

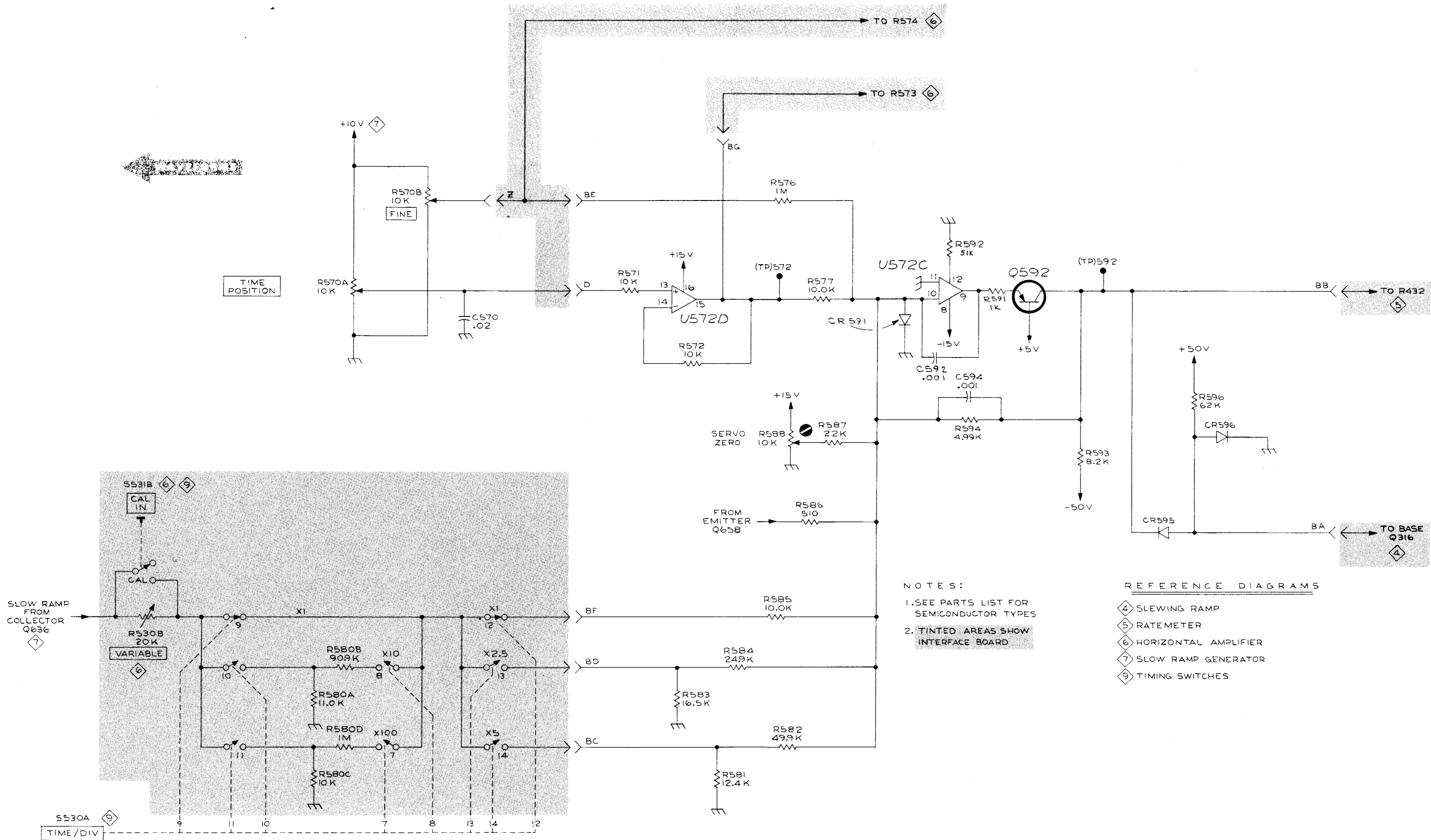

NOTES:
 1. SEE PARTS LIST FOR SEMICONDUCTOR TYPES
 2. TINTED AREAS SHOW INTERFACE BOARD

REFERENCE DIAGRAMS
 4 SLEWING RAMP
 5 RATEMETER
 6 HORIZONTAL AMPLIFIER
 7 SLOW RAMP GENERATOR
 9 TIMING SWITCHES

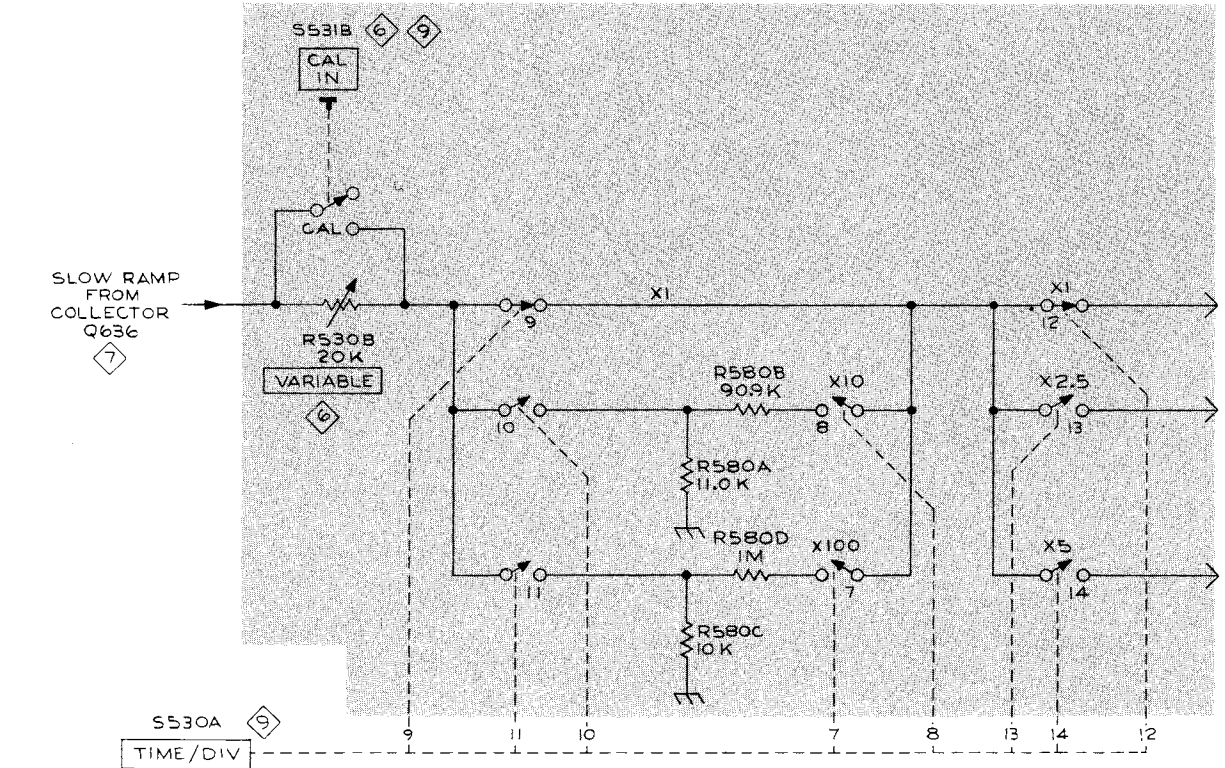

7TH SAMPLING SWEEP UNIT

REV E, APRIL 1975

GRS 772 SLOW RAMP INVERTER 8

SLOW RAMP INVERTER

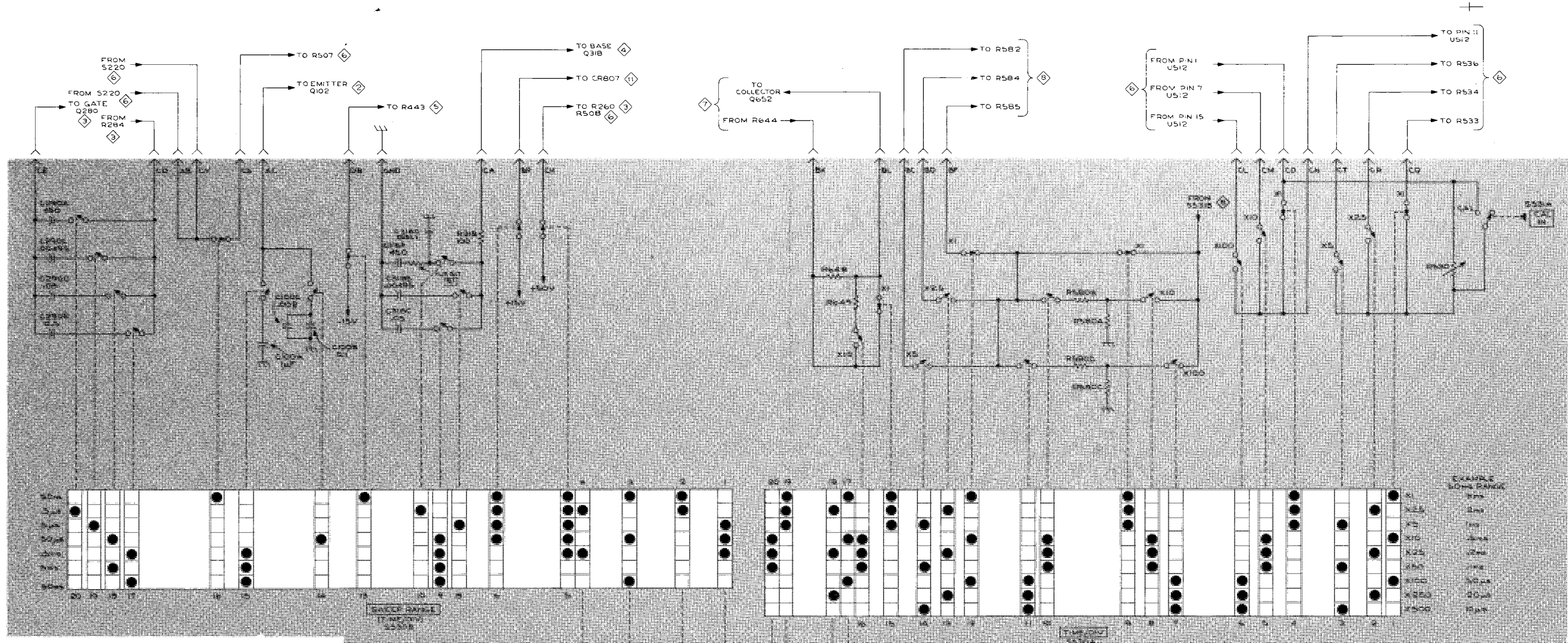

- REFERENCE DIAGRAMS
- ◇ TRIGGER & HOLD-OFF
 - ◇ TIME TO HEIGHT CONVERTER
 - ◇ SLEWING RAMP
 - ◇ RATEMETER
 - ◇ HORIZONTAL AMPLIFIER
 - ◇ SLOW RAMP GENERATOR
 - ◇ SLOW RAMP INVERTER
 - ◇ OUTPUT CONNECTORS

NOTE 5:

1. ● DENOTES SW SWITCH IN CLOSED POSITION
2. [] DENOTES SW SWITCH IN OPEN POSITION

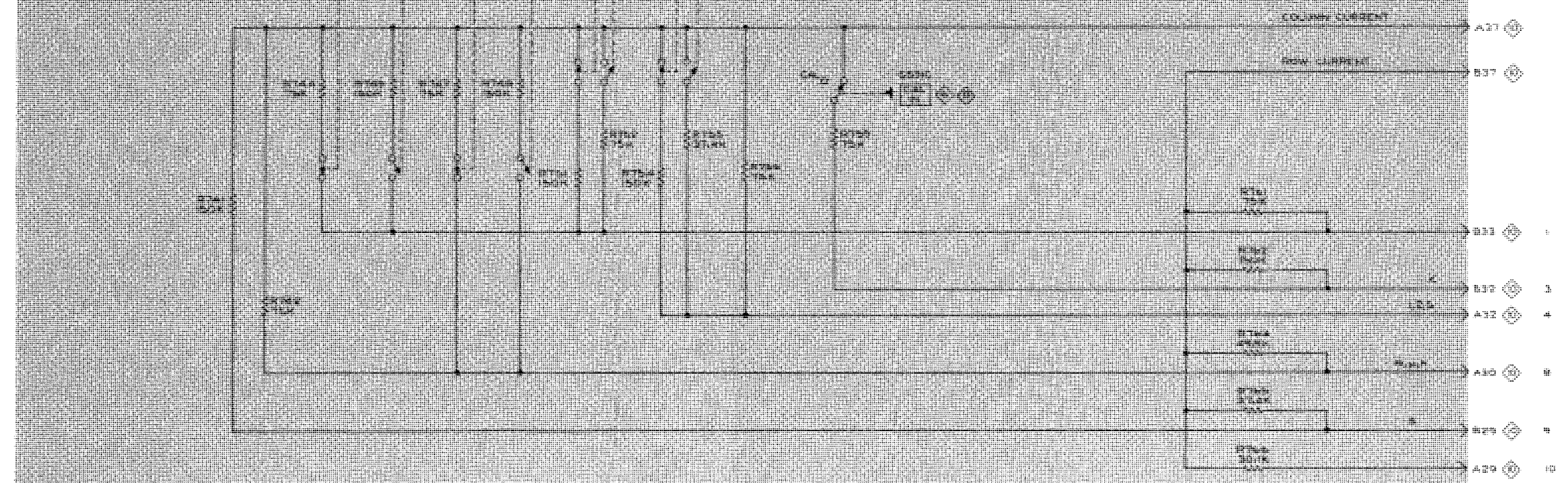

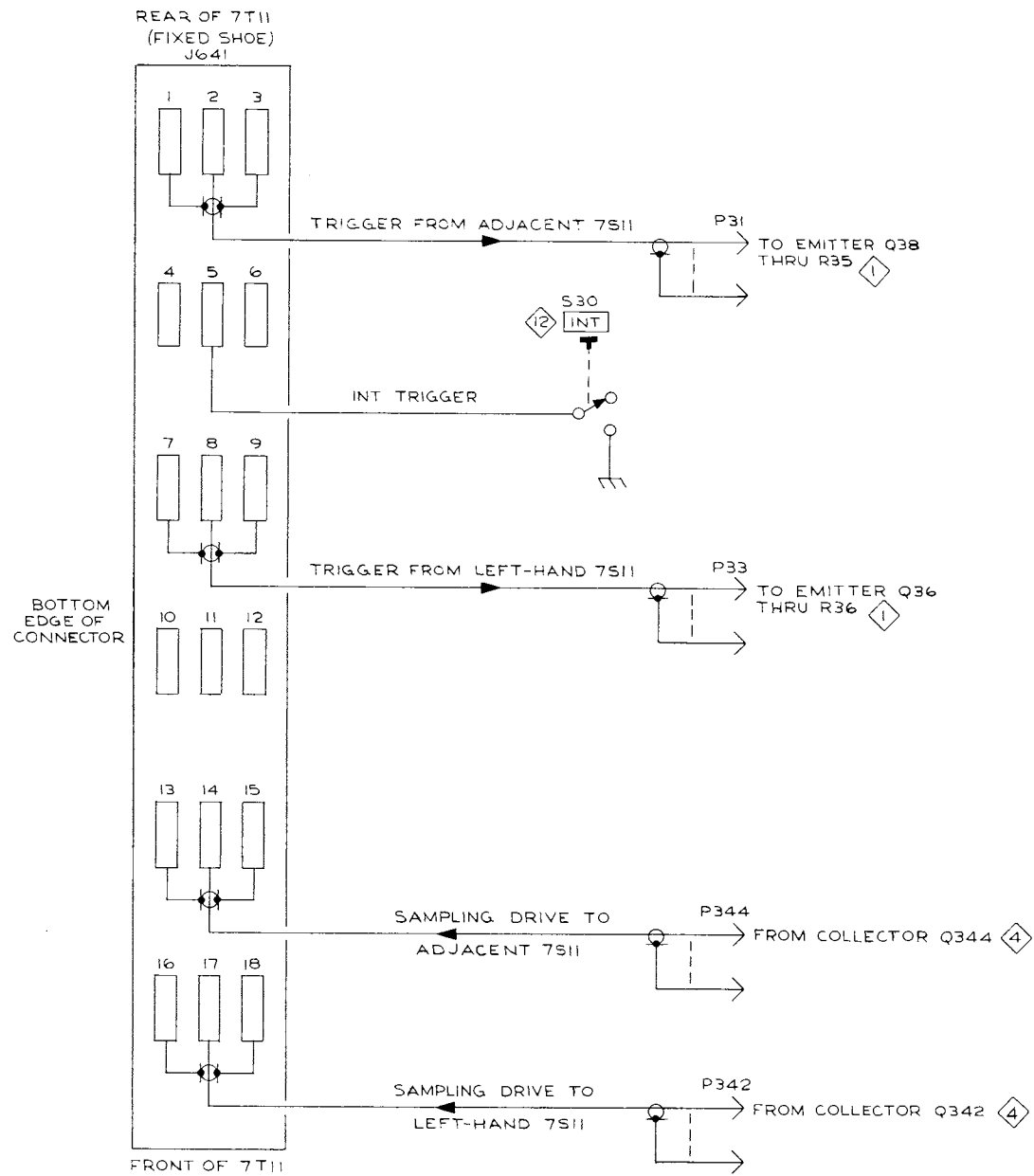

REFERENCE DIAGRAMS

- ① TRIGGER INPUT
- ② TRIGGER & HOLD-OFF
- ③ TIME TO HEIGHT CONVERTER
- ④ SLEWING RAMP
- ⑦ SLOW RAMP GENERATOR
- ⑨ TIMING SWITCHES
- ⑫ FRONT PANEL SWITCHING

NOTE:
TINTED AREA SHOWS
INTERFACE BOARD

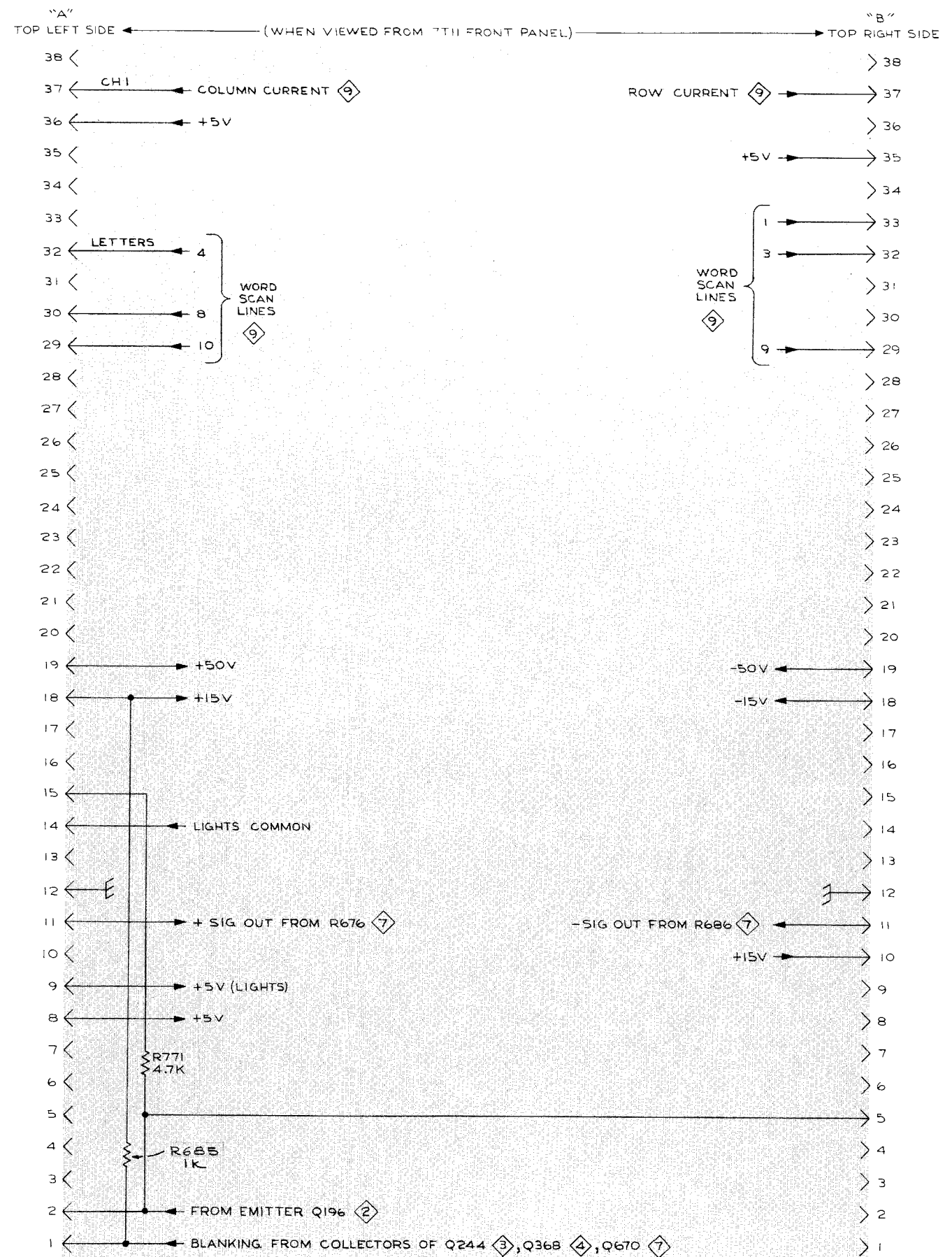

OUTPUT CONNECTORS

⑩

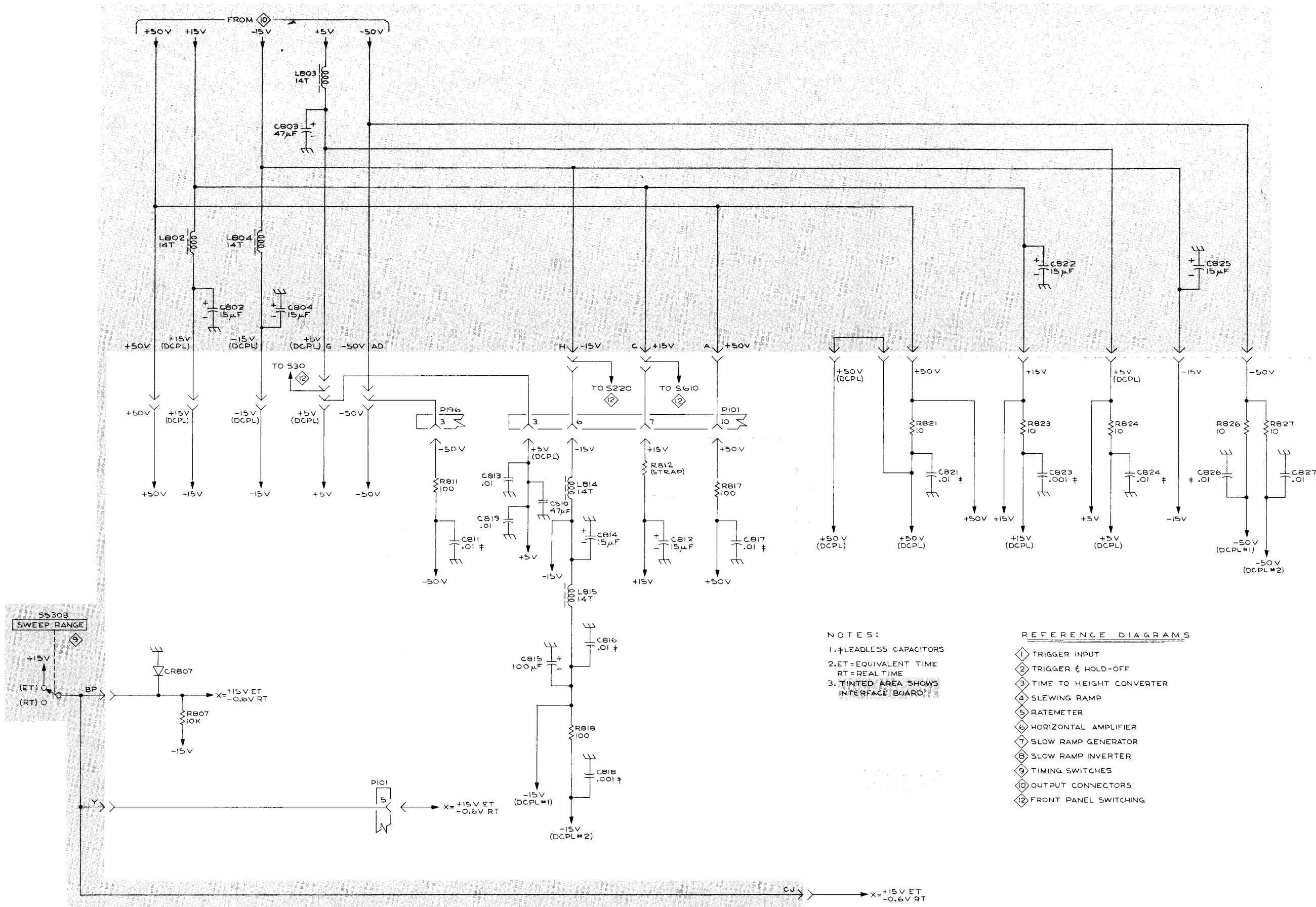

NOTES:
 1. † LEADLESS CAPACITORS
 2. ET = EQUIVALENT TIME
 RT = REAL TIME
 3. TINTED AREA SHOWS INTERFACE BOARD

- REFERENCE DIAGRAMS
- ① TRIGGER INPUT
 - ② TRIGGER & HOLD-OFF
 - ③ TIME TO HEIGHT CONVERTER
 - ④ SLEWING RAMP
 - ⑤ RATEMETER
 - ⑥ HORIZONTAL AMPLIFIER
 - ⑦ SLOW RAMP GENERATOR
 - ⑧ SLOW RAMP INVERTER
 - ⑨ TIMING SWITCHES
 - ⑩ OUTPUT CONNECTORS
 - ⑪ FRONT PANEL SWITCHING

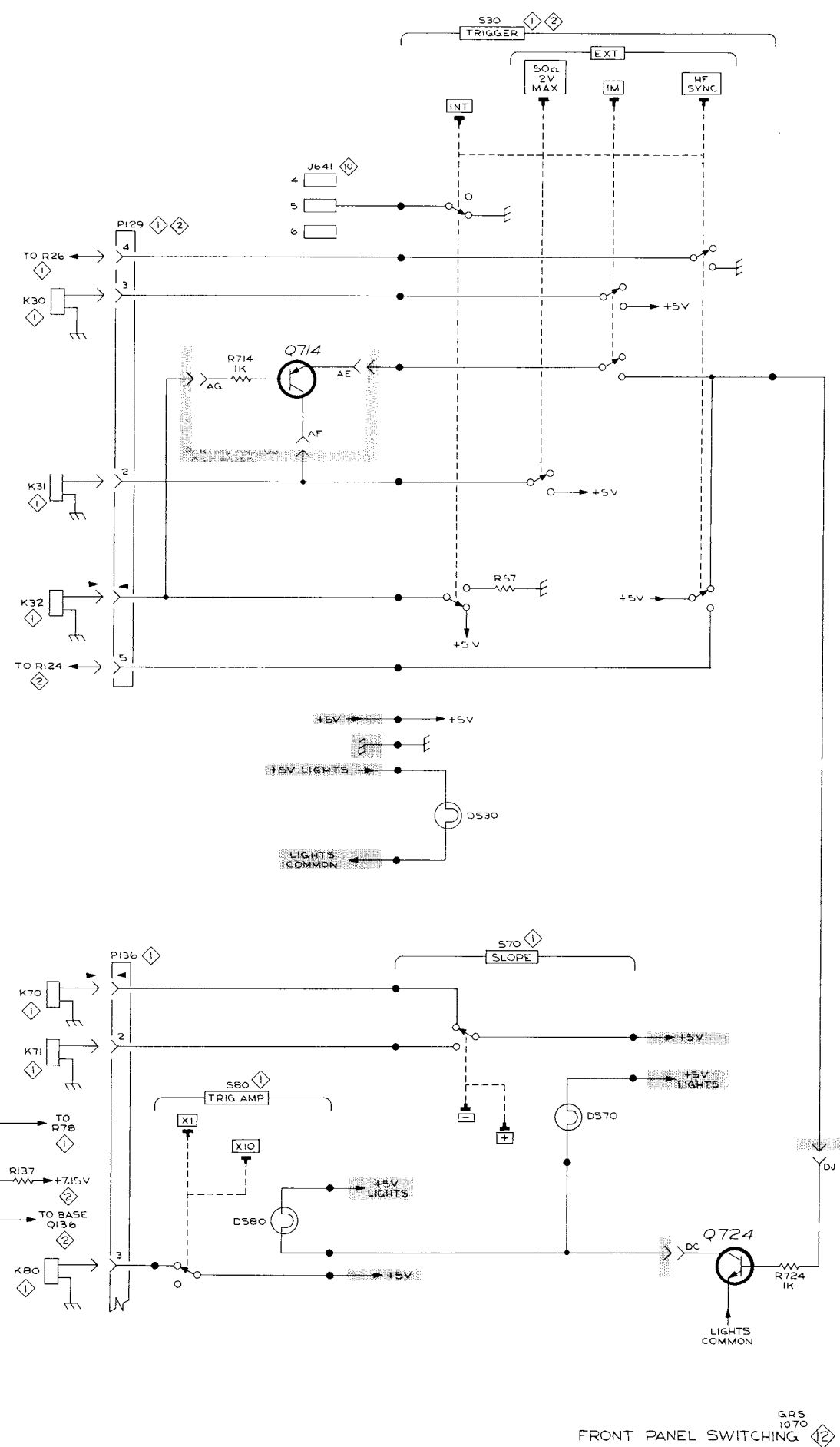
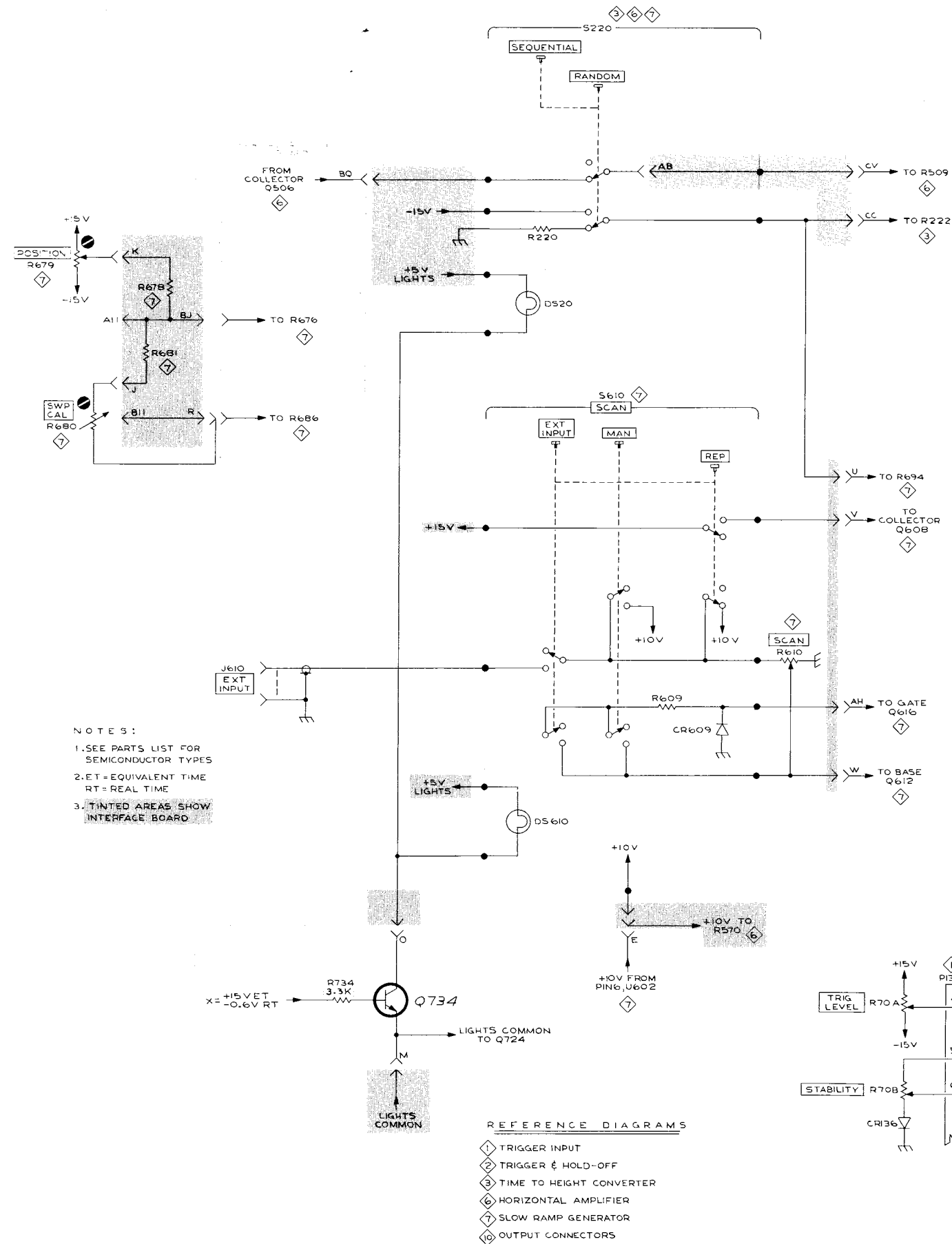

+

CARTON ASSEMBLY
(Part No. 065-0125-00)

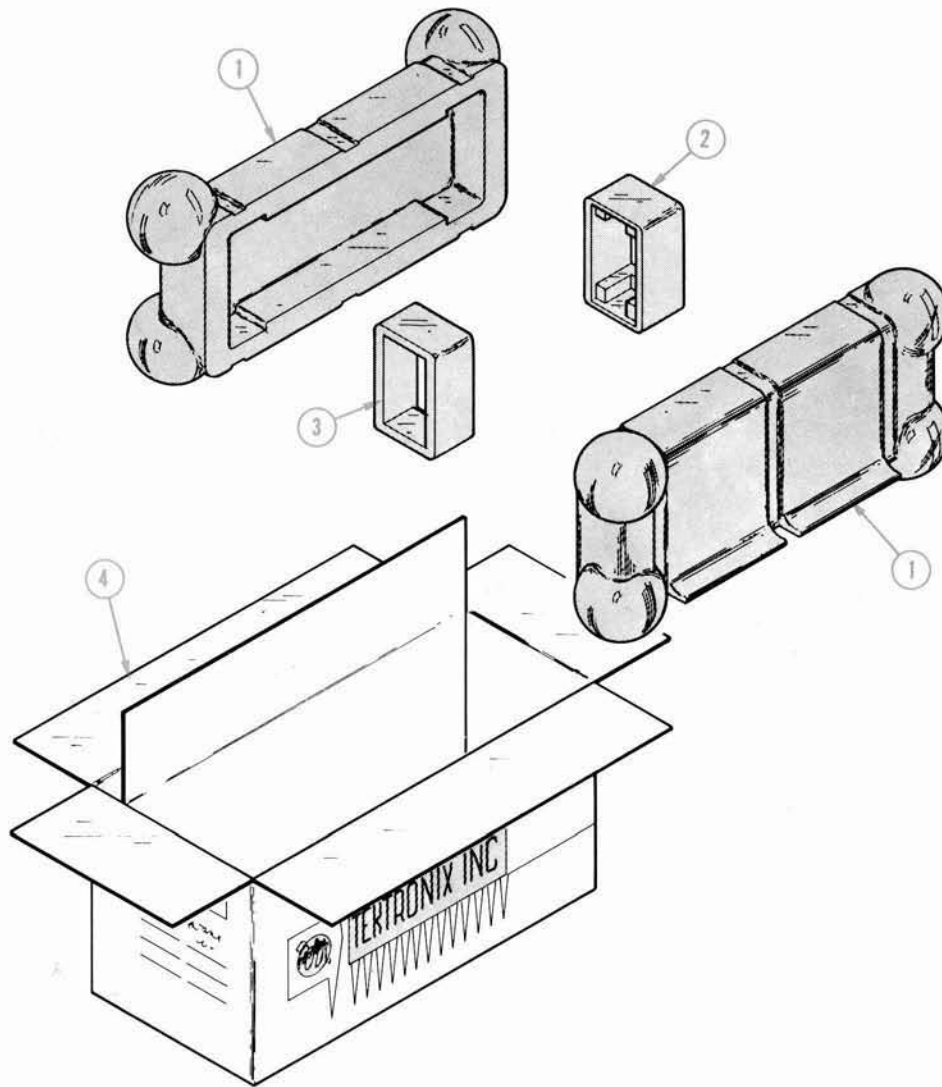

Fig. & Index No.	Tektronix Part No.	Serial/Model No.		Q	Description
		Eff	Disc		
3-	065-0125-00			1	ASSEMBLY, carton
-1	004-0241-00			-	assembly includes:
-2	004-0242-00			2	CASE HALF
-3	004-0243-00			1	END CAP, rear
-4	004-0748-00			1	END CAP, front
				1	CARTON

7T11 SAMPLING SWEEP UNIT

Scans by Outsource-Options =>

REPLACEABLE MECHANICAL PARTS

PARTS ORDERING INFORMATION

Replacement parts are available from or through your local Tektronix, Inc. Field Office or representative.

Changes to Tektronix instruments are sometimes made to accommodate improved components as they become available, and to give you the benefit of the latest circuit improvements developed in our engineering department. It is therefore important, when ordering parts, to include the following information in your order: Part number, instrument type or number, serial number, and modification number if applicable.

If a part you have ordered has been replaced with a new or improved part, your local Tektronix, Inc. Field Office or representative will contact you concerning any change in part number.

Change information, if any, is located at the rear of this manual.

SPECIAL NOTES AND SYMBOLS

X000 Part first added at this serial number
00X Part removed after this serial number

FIGURE AND INDEX NUMBERS

Items in this section are referenced by figure and index numbers to the illustrations.

INDENTATION SYSTEM

This mechanical parts list is indented to indicate item relationships. Following is an example of the indentation system used in the description column.

```

1 2 3 4 5           Name & Description
Assembly and/or Component
Attaching parts for Assembly and/or Component
  --- * ---
Detail Part of Assembly and/or Component
Attaching parts for Detail Part
  --- * ---
Parts of Detail Part
Attaching parts for Parts of Detail Part
  --- * ---

```

Attaching Parts always appear in the same indentation as the item it mounts, while the detail parts are indented to the right. Indented items are part of, and included with, the next higher indentation. The separation symbol --- * --- indicates the end of attaching parts.

Attaching parts must be purchased separately, unless otherwise specified.

ITEM NAME

In the Parts List, an Item Name is separated from the description by a colon (:). Because of space limitations, an Item Name may sometimes appear as incomplete. For further Item Name identification, the U.S. Federal Cataloging Handbook H6-1 can be utilized where possible.

ABBREVIATIONS

#	INCH NUMBER SIZE	ELECTRN	ELECTRON	IN	INCH	SE	SINGLE END
ACTR	ACTUATOR	ELEC	ELECTRICAL	INCAND	INCANDESCENT	SECT	SECTION
ADPTR	ADAPTER	ELCLTL	ELECTROLYTIC	INSUL	INSULATOR	SEMICOND	SEMICONDUCTOR
ALIGN	ALIGNMENT	ELEM	ELEMENT	INTL	INTERNAL	SHLD	SHIELD
AL	ALUMINUM	EPL	ELECTRICAL PARTS LIST	LPHLDR	LAMPHOLDER	SHLDR	SHOULDERED
ASSEM	ASSEMBLED	EQPT	EQUIPMENT	MACH	MACHINE	SKT	SOCKET
ASSY	ASSEMBLY	EXT	EXTERNAL	MECH	MECHANICAL	SL	SLIDE
ATTEN	ATTENUATOR	FIL	FILLISTER HEAD	MTG	MOUNTING	SLFLKG	SELF-LOCKING
AWG	AMERICAN WIRE GAGE	FLEX	FLEXIBLE	NIP	NIPPLE	SLVG	SLEEVING
BD	BOARD	FLH	FLAT HEAD	NON WIRE	NOT WIRE WOUND	SPR	SPRING
BRKT	BRACKET	FLTR	FILTER	OBD	ORDER BY DESCRIPTION	SQ	SQUARE
BRS	BRASS	FR	FRAME or FRONT	OD	OUTSIDE DIAMETER	SST	STAINLESS STEEL
BRZ	BRONZE	FSTNR	FASTENER	OZH	OVAL HEAD	STL	STEEL
BSHG	BUSHING	FT	FOOT	PH BRZ	PHOSPHOR BRONZE	SW	SWITCH
CAB	CABINET	FXD	FIXED	PL	PLAIN or PLATE	T	TUBE
CAP	CAPACITOR	GSKT	GASKET	PLSTC	PLASTIC	TERM	TERMINAL
CER	CERAMIC	HDL	HANDLE	PN	PART NUMBER	THD	THREAD
CHAS	CHASSIS	HEX	HEXAGON	PNH	PAN HEAD	THK	THICK
CKT	CIRCUIT	HEX HD	HEXAGONAL HEAD	PWR	POWER	TNSN	TENSION
COMP	COMPOSITION	HEX SOC	HEXAGONAL SOCKET	RCPT	RECEPTACLE	TPG	TAPPING
CONN	CONNECTOR	HLCPS	HELICAL COMPRESSION	RES	RESISTOR	TRH	TRUSS HEAD
COV	COVER	HLEXT	HELICAL EXTENSION	RGD	RIGID	V	VOLTAGE
CPLG	COUPLING	HV	HIGH VOLTAGE	RLF	RELIEF	VAR	VARIABLE
CRT	CATHODE RAY TUBE	IC	INTEGRATED CIRCUIT	RTNR	RETAINER	W/	WITH
DEG	DEGREE	ID	INSIDE DIAMETER	SCH	SOCKET HEAD	WSHR	WASHER
DWR	DRAWER	IDENT	IDENTIFICATION	SCOPE	OSCILLOSCOPE	XFMR	TRANSFORMER
		IMPLR	IMPELLER	SCR	SCREW	XSTR	TRANSISTOR

CROSS INDEX—MFR. CODE NUMBER TO MANUFACTURER

Mfr. Code	Manufacturer	Address	City, State, Zip
000BK	STAUFFER SUPPLY	105 SE TAYLOR	PORTLAND, OR 97214
000CY	NORTHWEST FASTENER SALES, INC.	7923 SW CIRRUS DRIVE	BEAVERTON, OR 97005
000FW	WESTERN SINTERING CO INC.	2620 STEVENS DRIVE	RICHLAND, WA 99352
00779	AMP, INC.	P O BOX 3608	HARRISBURG, PA 17105
12697	CLAROSTAT MFG. CO., INC.	LOWER WASHINGTON STREET	DOVER, NH 03820
22526	BERG ELECTRONICS, INC.	YOUK EXPRESSWAY	NEW CUMBERLAND, PA 17070
22599	ESNA, DIV. OF AMERACE CORPORATION	16150 STAGG STREET	VAN NUYS, CA 91409
25088	SIEMENS CORP.	186 WOOD AVE. S	ISELIN, NJ 08830
26805	OMNI SPECTRA INC., MICROWAVE CONNECTOR DIV.	140 FOURTH AVE	WALTHAM, MA 02154
55210	GETTIG ENG. AND MFG. COMPANY	PO BOX 85, OFF ROUTE 45	SPRING MILLS, PA 16875
59730	THOMAS AND BETTS COMPANY	36 BUTLER ST.	ELIZABETH, NJ 07207
70276	ALLEN MFG. CO.	P. O. DRAWER 570	HARTFORD, CT 06101
70318	ALLMETAL SCREW PRODUCTS CO., INC.	821 STEWART AVE.	GARDEN CITY, NY 11530
71785	TRW, CINCH CONNECTORS	1501 MORSE AVENUE	ELK GROVE VILLAGE, IL 60007
73743	FISCHER SPECIAL MFG. CO.	446 MORGAN ST.	CINCINNATI, OH 45206
73803	TEXAS INSTRUMENTS, INC., METALLURGICAL MATERIALS DIV.	34 FOREST STREET	ATTLEBORO, MA 02703
74445	HOLO-KROME CO.	31 BROOK ST. WEST	HARTFORD, CT 06110
74868	BUNKER-RAMO CORP., THE AMPHENOL RF DIV.	33 E. FRANKLIN ST.	DANBURY, CT 06810
77250	PHEOLL MANUFACTURING CO., DIVISION OF ALLIED PRODUCTS CORP.	5700 W. ROOSEVELT RD.	CHICAGO, IL 60650
78189	ILLINOIS TOOL WORKS, INC. SHAKEPROOF DIVISION	ST. CHARLES ROAD	ELGIN, IL 60120
79136	WALDES, KOHINOOR, INC.	47-16 AUSTEL PLACE	LONG ISLAND CITY, NY 11101
79807	WROUGHT WASHER MFG. CO.	2100 S. O BAY ST.	MILWAUKEE, WI 53207
80009	TEKTRONIX, INC.	P O BOX 500	BEAVERTON, OR 97077
83385	CENTRAL SCREW CO.	2530 CRESCENT DR.	BROADVIEW, IL 60153
86928	SEASTROM MFG. COMPANY, INC.	701 SONORA AVENUE	GLENDALE, CA 91201
87308	N. L. INDUSTRIES, INC., SOUTHERN SCREW DIV.	P. O. BOX 1360	STATESVILLE, NC 28677
93907	TEXTRON INC. CAMCAR DIV	600 18TH AVE	ROCKFORD, IL 61101
98291	SEALECTRO CORP.	225 HOYT	MAMARONECK, NY 10544

Fig. & Index No.	Tektronix Part No.	Serial/Model No. Eff Dscont	Qty	1	2	3	4	5	Name & Description	Mfr Code	Mfr Part Number
1-1	366-1064-00		1						KNOB:GRAY	80009	366-1064-00
	213-0153-00		1						. SETSCREW:5-40 X 0.125,STL BK OXD,HEX SKT	000CY	OBD
-2	366-1448-00	B010100 B049999	1						PUSH BUTTON:BLK,TO THETA	80009	366-1448-00
	366-1148-01	B050000	1						KNOB:GRAY	80009	366-1148-01
	213-0153-00		2						. SETSCREW:5-40 X 0.125,STL BK OXD,HEX SKT	000CY	OBD
-3	366-1183-00		1						KNOB:GRAY	80009	366-1183-00
	213-0725-00		1						. SETSCREW:3-48 X 0.095 INCH,HEX SOC STL	74445	OBD
-4	366-1101-00		1						KNOB:GRAY	80009	366-1101-00
	213-0153-00		1						. SETSCREW:5-40 X 0.125,STL BK OXD,HEX SKT	000CY	OBD
-5	366-1168-00		1						KNOB:BLACK CAP AND RED BODY	80009	366-1168-00
	213-0153-00		1						. SETSCREW:5-40 X 0.125,STL BK OXD,HEX SKT	000CY	OBD
-6	366-1196-00	B010100 B039999	1						KNOB:GRAY	80009	366-1196-00
	366-1258-00	B040000	1						KNOB:GRAY,MHZ/DIV	80009	366-1258-00
	213-0153-00		2						. SETSCREW:5-40 X 0.125,STL BK OXD,HEX SKT	000CY	OBD
-7	358-0383-00	B010100 B039999	1						BUSHING,SLEEVE:0.375 OD X 0.230 INCH LONG	80009	358-0383-00
	358-0414-00	B040000	1						BUSHING,SLEEVE:0.25 OD X 0.21 INCH LONG	80009	358-0414-00
-8	200-1011-01		1						CAP,KNOB:	80009	200-1011-01
-9	366-1204-00		1						KNOB:GRAY	80009	366-1204-00
	213-0153-00		2						. SETSCREW:5-40 X 0.125,STL BK OXD,HEX SKT	000CY	OBD
-10	331-0255-00		1						. DIAL,KNOB:	80009	331-0255-00
	210-0992-00		1						. WASHER,FLAT:0.265 ID X 0.01 THK,TEFLON	80009	210-0992-00
-11	366-1189-00		1						KNOB:GRAY	80009	366-1189-00
	213-0153-00		1						. SETSCREW:5-40 X 0.125,STL BK OXD,HEX SKT	000CY	OBD
-12	-----		1						RESISTOR,VAR:(SEE R570A,B REPL) (ATTACHING PARTS)		
-13	210-0046-00		2						WASHER,LOCK:0.261 ID,INTL,0.018 THK,BRS	78189	1214-05-00-0541C
	210-0940-00		1						WASHER,FLAT:0.25 ID X 0.375 INCH OD,STL	79807	OBD
-14	210-0583-00		2						NUT,PLAIN,HEX:0.25-32 X 0.312 INCH,BRS - - - * - - -	73743	2X20317-402
-15	-----		2						RESISTOR,VAR:(SEE R70 REPL) (ATTACHING PARTS)		
-16	210-0223-00		2						TERMINAL,LUG:0.25 INCH DIA,SE	86928	A313-136
	210-0940-00		2						WASHER,FLAT:0.25 ID X 0.375 INCH OD,STL	79807	OBD
-17	210-0583-00		2						NUT,PLAIN,HEX:0.25-32 X 0.312 INCH,BRS - - - * - - -	73743	2X20317-402
-18	-----		2						RESISTOR,VAR:(SEE R679,R680 REPL) (ATTACHING PARTS)		
-19	210-0046-00		4						WASHER,LOCK:0.261 ID,INTL,0.018 THK,BRS	78189	1214-05-00-0541C
-20	210-0471-00		2						NUT,SLEEVE:HEX.,0.312 X 0.594 INCH LONG	80009	210-0471-00
-21	358-0409-00		2						BSHG,MACH.THD:0.25-32 X 0.159 ID X 0.24 - - - * - - -	80009	358-0409-00
-22	670-1199-00	B010100 B019999	1						CKT BOARD ASSY:RANDOM SEQUENTIAL	80009	670-1199-00
	670-1199-01	B020000	1						CKT BOARD ASSY:RANDOM SEQUENTIAL	80009	670-1199-01
	380-0153-01		1						. HOUSING,PB:SST W/HEAT SINK (ATTACHING PARTS)	80009	380-0153-01
	213-0181-00		1						. SCR,TPG,THD FOR:2-32 X 0.375 INCH,PNH STL - - - * - - - (ATTACHING PARTS FOR CKT BD)	83385	OBD
-23	211-0156-00		1						SCREW,MACHINE:1-72 X 0.25",82 DEG,FLH STL - - - * - - -	93907	OBD
-24	670-1198-00	B010100 B019999	1						CKT BOARD ASSY:TRIGGER SLOPE	80009	670-1198-00
	670-1198-01	B020000	1						CKT BOARD ASSY:TRIGGER SLOPE	80009	670-1198-01
	380-0153-01		1						. HOUSING,PB:SST W/HEAT SINK (ATTACHING PARTS)	80009	380-0153-01
	213-0181-00		1						. SCR,TPG,THD FOR:2-32 X 0.375 INCH,PNH STL - - - * - - - (ATTACHING PARTS FOR CKT BD)	83385	OBD
	211-0156-00		1						SCREW,MACHINE:1-72 X 0.25",82 DEG,FLH STL - - - * - - -	93907	OBD
-25	670-1195-00	B010100 B019999	1						CKT BOARD ASSY:TRIGGER AMPL	80009	670-1195-00
	670-1195-01	B020000	1						CKT BOARD ASSY:TRIGGER AMPL	80009	670-1195-01
	380-0153-01		1						. HOUSING,PB:SST W/HEAT SINK (ATTACHING PARTS)	80009	380-0153-01
	213-0181-00		1						. SCR,TPG,THD FOR:2-32 X 0.375 INCH,PNH STL - - - * - - -	83385	OBD

Replaceable Mechanical Parts—7T11

Fig. & Index No.	Tektronix Part No.	Serial/Model No. Eff Dscont	Qty	1 2 3 4 5	Name & Description	Mfr Code	Mfr Part Number
1-	211-0156-00		1		(ATTACHING PARTS FOR CKT BD) SCREW,MACHINE:1-72 X 0.25",82 DEG,FLH STL - - - * - - -	93907	OBD
-26	670-1196-00	B010100 B019999	1		CKT BOARD ASSY:TRIGGER SOURCE	80009	670-1196-00
	670-1196-01	B020000	1		CKT BOARD ASSY:TRIGGER SOURCE	80009	670-1196-01
	380-0155-02		1		. HOUSING,PB:SST W/HEAT SINK (ATTACHING PARTS)	80009	380-0155-02
	213-0181-00		1		. SCR,TPG,THD FOR:2-32 X 0.375 INCH,PNH STL - - - * - - -	83385	OBD
	211-0156-00		2		(ATTACHING PARTS FOR CKT BD) SCREW,MACHINE:1-72 X 0.25",82 DEG,FLH STL - - - * - - -	93907	OBD
-27	670-1197-00	B010100 B019999	1		CKT BOARD ASSY:SCAN	80009	670-1197-00
	670-1197-01	B020000	1		CKT BOARD ASSY:SCAN	80009	670-1197-01
	380-0154-02		1		. HOUSING PB:SST W/HEAT SINK (ATTACHING PARTS)	80009	380-0154-02
	213-0181-00		1		. SCR,TPG,THD FOR:2-32 X 0.375 INCH,PNH STL - - - * - - -	83385	OBD
	211-0156-00		2		(ATTACHING PARTS FOR CKT BD) SCREW,MACHINE:1-72 X 0.25",82 DEG,FLH STL - - - * - - -	93907	OBD
-28	333-1234-00		1		PANEL,FRONT:	80009	333-1234-00
-29	386-1447-22		1		SUBPANEL,FRONT:	80009	386-1447-22
-30	366-1058-12		1		KNOB:LATCH (ATTACHING PARTS)	80009	366-1058-12
-31	214-1095-00		1		PIN,SPG,SPLIT:0.094 OD X 0.187 INCH LONG - - - * - - -	22599	52-022-094-0187
-32	105-0076-02		1		REL BAR,LATCH:PLUG-IN UNIT	80009	105-0076-02
-33	214-1280-00		1		SPRING,HLCPS:0.14 OD X 1.126"L,0.16"DIA W	80009	214-1280-00
-34	214-1054-00		1		SPRING,FLAT:0.825 X 0.322,SST	80009	214-1054-00
-35	105-0075-00		1		BOLT,LATCH:7A & 7B SER PL-IN	80009	105-0075-00
-36	214-1061-00		1		SPRING,GROUND:FLAT	80009	214-1061-00
-37	348-0235-00		2		SHLD GSKT,ELEC:4.734 INCH LONG	80009	348-0235-00
-38	358-0301-02		2		BUSHING,SLEEVE:GRAY PLASTIC	80009	358-0301-02
-39	131-0779-00		2		JACK,TIP:FOR 0.08 INCH DIA TEST POINT	98291	016-8010-00-0208
-40	352-0216-00		1		HOLDER,TIP JACK: (ATTACHING PARTS)	80009	352-0216-00
-41	211-0060-00		1		SCREW,MACHINE:2-56 X 0.438,FLH,82 DEG STL	77250	OBD
	210-0001-00		1		WASHER,LOCK:INTL,0.092 ID X 0.18"OD,STL	78189	1202-00-00-0541C
-42	210-0405-00		1		NUT,PLAIN,HEX.:2-56 X 0.188 INCH,BRS - - - * - - -	73743	12157-50
-43	131-0850-00		1		CONN,FEEDTHRU:3MM FEMALE EAEND (ATTACHING PARTS)	26805	2084-5059-24
-44	220-0531-02		1		NUT,PLAIN,HEX.:0.25-36 X 0.312 INCH,STL - - - * - - -	80009	220-0531-02
-45	175-1154-00		1		CA ASSY,SP,ELEC:	80009	175-1154-00
	175-0068-00		FT		. CABLE,RF:50 OHM	80009	175-0068-00
-46	131-0888-00		1		. CONNECTOR,PLUG,:MALE	26805	2031-5006-95
-47	131-0155-00		1		. CONNECTOR,PLUG,:FEMALE	74868	27-1
-48	131-0579-00		1		CONNECTOR,RCPT,:MALE	74868	46475-1050
-49	131-0155-00		1		CONNECTOR,PLUG,:FEMALE	74868	27-1
-50	670-1121-00	B010100 B029999	1		CKT BOARD ASSY:INTERFACE	80009	670-1121-00
	670-1121-01	B030000 B089999	1		CKT BOARD ASSY:INTERFACE	80009	670-1121-01
	670-1121-02	B090000 B090000	1		CKT BOARD ASSY:INTERFACE	80009	670-1121-02
	670-1121-04	B100000	1		CKT BOARD ASSY:INTERFACE	80009	670-1121-04
	131-0566-00	B010100 B089999	7		. BUS CONDUCTOR:DUMMY RES,2.375,22 AWG	55210	L-2007-1
	131-0566-00	B090000 B109999	3		. BUS CONDUCTOR:DUMMY RES,2.375,22 AWG	55210	L-2007-1
	131-0566-00	B110000	4		. BUS CONDUCTOR:DUMMY RES,2.375,22 AWG	55210	L-2007-1
-51	131-0590-00		36		. CONTACT,ELEC:0.71 INCH LONG	22526	47351
	131-0592-00		34		. CONTACT,ELEC:0.885 INCH LONG	22526	47353
	131-0608-00		14		. TERMINAL,PIN:0.365 L X 0.025 PH BRZ GOLD	22526	47357
	131-0665-00		10		. TERMINAL,PIN:0.88 L X 0.025 SQUARE	22526	47358
-52	131-0604-00		41		. CONTACT,ELEC:CKT BD SW,SPR,CU BE	80009	131-0604-00

Replaceable Mechanical Parts—7T11

Fig. & Index No.	Tektronix Part No.	Serial/Model No. Eff Dscont	Qty	1	2	3	4	5	Name & Description	Mfr Code	Mfr Part Number
1-53	351-0155-00		34	.					INSULATOR,STDF:CONNECTOR,DELTRIN	80009	351-0155-00
-54	351-0186-00		2	.					GUIDE-POST,LOCK:0.84 INCH LONG	80009	351-0186-00
-55	351-0227-00		4	.					GUIDE-POST,LOCK:0.84 INCH LONG	80009	351-0227-00
	105-0330-00		1	.					ACTR ASSY,CAM S:SWEEP RANGE	80009	105-0330-00
-56	354-0219-00		1	.					RING,RETAINING:FOR 0.25 INCH SHAFT	79136	5103-25-MD-R
-57	214-1139-00		-	.					SPRING,FLAT:0.885 X 0.156CU BE GLD CLR	80009	214-1139-00
	-----		-	.					(REPLACE ONLY WITH PART BEARING THE SAME		
	-----		-	.					COLOR CODE AS THE ORIGINAL PART IN YOUR		
	-----		-	.					INSTRUMENT)		
	214-1139-02		-	.					SPRING,FLAT:GREEN COLORED	80009	214-1139-02
	-----		-	.					(SEE FOOTNOTE ON FIG.1-57)		
	214-1139-03		-	.					SPRING,FLAT:RED COLORED	80009	214-1139-03
	-----		-	.					(SEE FOOTNOTE ON FIG.1-57)		
-58	214-1127-00		1	.					ROLLER,DETENT:0.125 DIA X 0.125,SST	80009	214-1127-00
-59	401-0054-00		1	.					BEARING,CAM SW:FRONT	80009	401-0054-00
-60	105-0138-00		1	.					ACTUATOR,CAM SW:	80009	105-0138-00
-61	384-0493-00		1	.					SHAFT,STRAIGHT:CAM SW,3.875 INCH LONG	80009	384-0493-00
-62	401-0068-00		1	.					BEARING,CAM SW:REAR	80009	401-0068-00
-63	200-0952-00		1	.					COVER,CAM SW:20 ELEMENTS	80009	200-0952-00
									(ATTACHING PARTS)		
-64	211-0022-00		2	.					SCREW,MACHINE:2-56 X 0.188 INCH,PNH STL	83385	OBD
	210-0001-00		2	.					WASHER,LOCK:INTL,0.092 ID X 0.18"OD,STL	78189	1202-00-00-0541C
	210-0405-00		2	.					NUT,PLAIN,HEX.:2-56 X 0.188 INCH,BRS	73743	12157-50
									-----*		
-65	210-0406-00		4	.					NUT,PLAIN,HEX.:4-40 X 0.188 INCH,BRS	73743	12161-50
									(ATTACHING PARTS FOR ACTR ASSY)		
-66	211-0116-00	B010100 B212929	4	.					SCR,ASSEM WSHR:4-40 X 0.312 INCH,PNH BRS	83385	OBD
	211-0292-00	B212930	4	.					SCR,ASSEM WSHR:4-40 X 0.29,BRS NI PL	78189	OBD
									-----*		
	105-0329-00		1	.					ACTR ASSY,CAM S:TIME/CM	80009	105-0329-00
-67	354-0390-00		1	.					RING,RETAINING:0.338 ID X 0.025" THK,STL	79136	5100-37MD
-68	214-1139-00		-	.					SPRING,FLAT:0.885 X 0.156CU BE GLD CLR	80009	214-1139-00
	-----		-	.					(SEE FOOTNOTE ON FIG.1-57)		
	214-1139-02		-	.					SPRING,FLAT:GREEN COLORED	80009	214-1139-02
	-----		-	.					(SEE FOOTNOTE ON FIG.1-57)		
	214-1139-03		-	.					SPRING,FLAT:RED COLORED	80009	214-1139-03
	-----		-	.					(SEE FOOTNOTE ON FIG.1-57)		
-69	214-1127-00		1	.					ROLLER,DETENT:0.125 DIA X 0.125,SST	80009	214-1127-00
-70	401-0065-00		1	.					BEARING,CAM SW:FRONT	80009	401-0065-00
-71	105-0137-00		1	.					ACTUATOR,CAM SW:	80009	105-0137-00
-72	384-0494-00		1	.					EXTENSION SHAFT:5.125 INCH LONG	80009	384-0494-00
-73	200-0952-00		1	.					COVER,CAM SW:20 ELEMENTS	80009	200-0952-00
									(ATTACHING PARTS)		
-74	211-0022-00		2	.					SCREW,MACHINE:2-56 X 0.188 INCH,PNH STL	83385	OBD
-75	210-0001-00		2	.					WASHER,LOCK:INTL,0.092 ID X 0.18"OD,STL	78189	1202-00-00-0541C
	210-0405-00		2	.					NUT,PLAIN,HEX.:2-56 X 0.188 INCH,BRS	73743	12157-50
									-----*		
-76	401-0056-00		1	.					BEARING,CAM SW:REAR	80009	401-0056-00
-77	210-0406-00		4	.					NUT,PLAIN,HEX.:4-40 X 0.188 INCH,BRS	73743	12161-50
									(ATTACHING PARTS FOR ACTR ASSY)		
	211-0116-00	B010100 B212929	4	.					SCR,ASSEM WSHR:4-40 X 0.312 INCH,PNH BRS	83385	OBD
	211-0292-00	B212930	4	.					SCR,ASSEM WSHR:4-40 X 0.29,BRS NI PL	78189	OBD
									-----*		
-78	214-1190-00		1	.					CPLG,SHAFT,RGD:0.125 OD TO 0.125 OD,AL	80009	214-1190-00
	213-0075-00		1	.					SETSCREW:4-40 X 0.094,STL BK OXD,HEX SKT	000BK	OBD
	213-0140-00		1	.					SETSCREW:2-56 X 0.94 INCH,HEX SOC STL	70276	OBD
-79	384-0348-01		1	.					EXTENSION SHAFT:0.125 DIA X 9.161 INCH L	80009	384-0348-01
-80	407-0553-00	B010100 B010149	1	.					BRACKET,CMPNT:BRASS ALBALOYPL	80009	407-0553-00
	407-0803-00	B010150	1	.					BRACKET,ELEC SW:BRASS	80009	407-0803-00
-81	-----		1	.					RESISTOR,VAR:		
									(ATTACHING PARTS)		
	210-0046-00		1	.					WASHER,LOCK:0.261 ID,INTL,0.018 THK,BRS	78189	1214-05-00-0541C
-82	210-0583-00		1	.					NUT,PLAIN,HEX:0.25-32 X 0.312 INCH,BRS	73743	2X20317-402
									-----*		
-83	214-1136-00		1	.					ACTUATOR,SL SW:DUAL DPST	80009	214-1136-00

Replaceable Mechanical Parts—7T11

Fig. & Index No.	Tektronix Part No.	Serial/Model No. Eff	Dscont	Qty	1 2 3 4 5	Name & Description	Mfr Code	Mfr Part Number
1-84	351-0180-00			1		. SLIDE, GUIDE: SWITCH ACTUATOR (ATTACHING PARTS FOR CKT BOARD)	80009	351-0180-00
	211-0116-00	B010100	B212929	6		SCR, ASSEM WSHR: 4-40 X 0.312 INCH, PNH BRS	83385	OBD
	211-0292-00	B212930		6		. SCR, ASSEM WSHR: 4-40 X 0.29, BRS NI PL	78189	OBD
-85	220-0547-01			6		NUT, BLOCK: 0.38 X 0.26 X 0.282 (2) 4-40 THD	000FW	OBD
-86	211-0105-00			6		SCREW, MACHINE: 4-40 X 0.188, 100 DEG, FLH STL	83385	OBD
-87	210-1096-00			1		WASHER, KEY: 0.375 ID X 0.175 THK, AL	80009	210-1096-00
-88	210-0413-00			1		NUT, PLAIN, HEX.: 0.375-32 X 0.50 INCH, STL	73743	3145-402
						- - - * - - -		
-89	670-1118-00	B010100	B029999	1		CKT BOARD ASSY: LOGIC	80009	670-1118-00
	670-1118-01	B030000	B059999	1		CKT BOARD ASSY: LOGIC	80009	670-1118-01
	670-1118-02	B060000	B069999	1		CKT BOARD ASSY: LOGIC	80009	670-1118-02
	670-1118-03	B070000	B079999	1		CKT BOARD ASSY: LOGIC	80009	670-1118-03
	670-1118-04	B080000	B090000	1		CKT BOARD ASSY: LOGIC	80009	670-1118-04
	670-1118-05	B100000	B119999	1		CKT BOARD ASSY: LOGIC	80009	670-1118-05
	670-1118-06	B120000	B201370	1		CKT BOARD ASSY: LOGIC	80009	670-1118-06
	670-1118-07	B201371	B222994	1		. CKT BOARD ASSY: ANALOG LOGIC	80009	670-1118-07
	670-1118-08	B222995		1		. CKT BOARD ASSY: LOGIC	80009	670-1118-08
-90	131-0566-00			1		. BUS CONDUCTOR: DUMMY RES, 2.375, 22 AWG	55210	L-2007-1
-91	136-0183-00			1		. SOCKET, PLUG-IN: 3 PIN, ROUND	80009	136-0183-00
-92	136-0220-00			22		. SKT, PL-IN ELEK: TRANSISTOR 3 CONTACT, PCB MT	71785	133-23-11-034
-93	136-0235-00			2		. SOCKET, PLUG-IN: 6 CONTACT, ROUND	71785	133-96-12-062
-94	136-0260-02			1		. SKT, PL-IN ELEK: MICROCIRCUIT, 16 DIP, LOW CLE	71785	133-51-92-008
-95	136-0263-03	B010100	B201534	34		. SOCKET, PIN TERM: FOR 0.025 INCH SQUARE PIN	00779	85864-2
	136-0263-04	B201535		34		. SOCKET, PIN TERM: FOR 0.025 INCH SQUARE PIN	22526	75377-001
-96	136-0252-01	B010100	B212079	1		. CONTACT, ELEC: 0.178 INCH LONG	00779	1-332095-2
	136-0252-07	B212080		81		. SOCKET, PIN CONN: W/O DIMPLE	22526	75060-012
-97	214-0579-00			8		. TERM, TEST POINT: BRS CD PL	80009	214-0579-00
-98	211-0155-00			3		. SCREW, EXT, RLV B: 4-40 X 0.375 INCH, SST	80009	211-0155-00
-99	361-0238-00			3		. SPACER, SLEEVE: 0.25 OD X 0.34 INCH LONG	80009	361-0238-00
-100	670-1119-00	B010100	B019999	1		CKT BOARD ASSY: TIMING	80009	670-1119-00
	670-1119-01	B020000	B029999	1		CKT BOARD ASSY: TIMING	80009	670-1119-01
	670-1119-02	B030000	B049999	1		CKT BOARD ASSY: TIMING	80009	670-1119-02
	670-1119-03	B050000	B079999	1		CKT BOARD ASSY: TIMING	80009	670-1119-03
	670-1119-04	B080000	B119999	1		CKT BOARD ASSY: TIMING	80009	670-1119-04
	670-1119-06	B120000	B139999	1		CKT BOARD ASSY: TIMING	80009	670-1119-06
	670-1119-07	B140000	B149999	1		CKT BOARD ASSY: TIMING	80009	670-1119-07
	670-1119-08	B150000	B212079	1		CKT BOARD ASSY: TIMING	80009	670-1119-08
	670-1119-09	B212080	B222994	1		CKT BOARD ASSY: TIMING	80009	670-1119-09
	670-1119-10	B222995		1		CKT BOARD ASSY: TIMING	80009	670-1119-10
	131-0155-00			1		. CONNECTOR, PLUG: FEMALE	74868	27-1
-101	214-0579-00			1		. TERM, TEST POINT: BRS CD PL	80009	214-0579-00
-102	131-0265-00			2		. CONNECTOR, RCPT: RIGHT ANGLE MOUNT	98291	51-053-0000
-103	136-0252-01	B010100	B212079	10		. CONTACT, ELEC: 0.178 INCH LONG	00779	1-332095-2
	136-0252-07	B212080		181		. SOCKET, PIN CONN: W/O DIMPLE	22526	75060-012
-104	136-0260-02			1		. SKT, PL-IN ELEK: MICROCIRCUIT, 16 DIP, LOW CLE	71785	133-51-92-008
-105	136-0263-03	B010100	B201534	46		. SOCKET, PIN TERM: FOR 0.025 INCH SQUARE PIN	00779	85864-2
	136-0263-04	B201535		46		. SOCKET, PIN TERM: FOR 0.025 INCH SQUARE PIN	22526	75377-001
-106	136-0350-00	B010100	B212079X	48		. SOCKET, PLUG-IN: 3 PIN, LOW PROFILE	80009	136-0350-00
-107	136-0365-00	B010100	B212079X	3		. SKT, PL-IN ELEK: TRANSISTOR, 3 CONTACT	80009	136-0365-00
-108	136-0366-00	B010100	B212079X	3		. SOCKET, PLUG-IN: 6 PIN	80009	136-0366-00
-109	210-0707-00			1		. EYELET, METALLIC: 0.147 OD X 0.100 INCH LONG	12697	OBD
-110	214-0579-00			14		. TERM, TEST POINT: BRS CD PL (ATTACHING PARTS FOR CKT BOARD)	80009	214-0579-00
-111	220-0561-00			4		NUT, PLAIN, HEX.: 10-32 X 0.25 INCH, BRS - - - * - - -	80009	220-0561-00
-112	670-1120-00	B010100	B019999	1		CKT BOARD ASSY: TRIGGER	80009	670-1120-00
	670-1120-01	B020000	B049999	1		CKT BOARD ASSY: TRIGGER	80009	670-1120-01
	670-1120-02	B050000	B079999	1		CKT BOARD ASSY: TRIGGER	80009	670-1120-02
	670-1120-03	B080000	B129999	1		CKT BOARD ASSY: TRIGGER	80009	670-1120-03
	670-1120-04	B222994		1		CKT BOARD ASSY: TRIGGER	80009	670-1120-04
	670-1120-05	B222995		1		CKT BOARD ASSY: TRIGGER	80009	670-1120-05
	131-0566-00	XB110000		1		. BUS CONDUCTOR: DUMMY RES, 2.375, 22 AWG	55210	L-2007-1
-113	131-0265-00			5		. CONNECTOR, RCPT: RIGHT ANGLE MOUNT	98291	51-053-0000
-114	131-0589-00			24		. TERMINAL, PIN: 0.46 L X 0.025 SQ	80009	131-0589-00

Replaceable Mechanical Parts—7T11

Fig. & Index No.	Tektronix Part No.	Serial/Model No. Eff	Dscont	Qty	1	2	3	4	5	Name & Description	Mfr Code	Mfr Part Number
1-115	214-0579-00			1	.	TERM, TEST POINT: BRS CD PL					80009	214-0579-00
-116	136-0252-01	B010100	B212079	10	.	CONTACT, ELEC: 0.178 INCH LONG					00779	1-332095-2
	136-0252-07	B212080		67	.	SOCKET, PIN CONN: W/O DIMPLE					22526	75060-012
-117	136-0269-02			1	.	SKT, PL-IN ELEK: MICROCIRCUIT, 14 DIP, LOW CLE					73803	CS9002-14
-118	136-0350-00			19	.	SOCKET, PLUG-IN: 3 PIN, LOW PROFILE					80009	136-0350-00
-119	214-0579-00			5	.	TERM, TEST POINT: BRS CD PL					80009	214-0579-00
-120	344-0089-00			1	.	CLIP, ELECTRICAL: TUNNEL DIODE, BERYLCO					80009	344-0089-00
-121	361-0305-00			5	.	SPACER, SLEEVE: 0.563 INCH LONG					80009	361-0305-00
-122	352-0220-00			1	.	HOLDER, MODULE: PHOTOCONDUCTOR, CKT BD MT					80009	352-0220-00
-123	352-0228-00			1	.	HOLDER, CABLE: FOR 0.125" DIA CABLE, PLASTIC					80009	352-0228-00
-124	361-0301-00			4	.	SPACER, SLEEVE: 4-40 X 0.105 INCH LONG					80009	361-0301-00
-125	211-0155-00			4	.	SCREW, EXT, RLV B: 4-40 X 0.375 INCH, SST					80009	211-0155-00
-126	210-0707-00			2	.	EYELET, METALLIC: 0.147 OD X 0.100 INCH LONG					12697	OBD
-127	386-1680-00			1	.	PLATE, RETAINING: ALUMINUM					80009	386-1680-00
						(ATTACHING PARTS)						
-128	211-0513-00			2	.	SCREW, MACHINE: 6-32 X 0.625 INCH, PNH STL					83385	OBD
-129	166-0222-00			2	.	INS SLV, ELEC: 0.325 INCH LONG					80009	166-0222-00
-130	210-0457-00			2	.	NUT, PL, ASSEM WA: 6-32 X 0.312 INCH, STL					83385	OBD
						- - - - *						
-131	670-1184-00			1	.	CKT BOARD: COMMUTATOR					80009	670-1184-00
-132	211-0087-00			3	.	SCREW, MACHINE: 2-56 X 0.188 INCH, FLH SST					70318	OBD
	210-0001-00			3	.	WASHER, LOCK: INTL, 0.092 ID X 0.18" OD, STL					78189	1202-00-00-0541C
-133	210-0405-00			3	.	NUT, PLAIN, HEX.: 2-56 X 0.188 INCH, BRS					73743	12157-50
-134	204-0410-00			1	.	BODY HALF, COMM: STATIONARY					80009	204-0410-00
-135	131-0842-00			4	.	TERMINAL, LUG: 0.76 ID X 0.225 L BRS CD PL					80009	131-0842-00
-136	131-0155-00			4	.	CONNECTOR, PLUG.: FEMALE					74868	27-1
						(ATTACHING PARTS FOR CKT BOARD)						
-137	211-0038-00			3	.	SCREW, MACHINE: 4-40 X 0.312, FLH, 100 DEG					83385	OBD
-138	210-0586-00			3	.	NUT, PL, ASSEM WA: 4-40 X 0.25, STL CD PL					83385	OBD
						- - - - *						
-139	426-0499-09			1	.	FR SECT, PLUG-IN: BOTTOM					80009	426-0499-09
						(ATTACHING PARTS)						
-140	213-0192-00	B010100	B223184	4	.	SCR, TPG, THD FOR: 6-32 X 0.50 INCH, PNH STL					87308	OBD
	213-0793-00	B223185		4	.	SCREW, TPG, TF: 6-32 X 0.4375, TAPTITE, FIL					93907	OBD
						- - - - *						
-141	426-0505-06			1	.	FR SECT, PLUG-IN: TOP					80009	426-0505-06
						(ATTACHING PARTS)						
-142	213-0192-00	B010100	B223184	4	.	SCR, TPG, THD FOR: 6-32 X 0.50 INCH, PNH STL					87308	OBD
	213-0793-00	B223185		4	.	SCREW, TPG, TF: 6-32 X 0.4375, TAPTITE, FIL					93907	OBD
-143	361-0326-00			1	.	SPACER, SLEEVE: 0.18 ID X 0.25 OD X 0.10" L					80009	361-0326-00
						- - - - *						
-144	386-1402-00			1	.	PANEL, REAR:					80009	386-1402-00
-145	337-1238-00	B010100	B129999	1	.	SHIELD, ELEC: LEFT SIDE					80009	337-1238-00
	337-1238-01	B130000		1	.	SHIELD, ELEC: LEFT SIDE					80009	337-1238-01
-146	337-1163-00	B010100	B129999	1	.	SHIELD, ELEC: RIGHT SIDE					80009	337-1163-00
	337-1163-01	B130000		1	.	SHLD, ELECTRICAL: RIGHT SIDE					80009	337-1163-01
	342-0199-00	XB170000		1	.	INSULATOR, PLATE: SIDE PANEL					80009	342-0199-00
-147	179-1526-00			1	.	WIRING HARNESS.: INTERFACE					80009	179-1526-00
-148	131-0512-00			39	.	CONTACT, ELEC: 0.315 " L, 22-26 AWG WIRE					00779	61507-1
-149	131-0707-00			13	.	CONNECTOR, TERM: 22-26 AWG, BRS & CU BE GOLD					22526	47439
-150	352-0161-00			1	.	HLD, TERM CONN: 3 WIRE BLACK					80009	352-0161-00
-151	352-0168-00			1	.	CONN BODY, PL, EL: 10 WIRE BLACK					80009	352-0168-00
-152	352-0163-00			1	.	CONN BODY, PL, EL: 5 WIRE BLACK					80009	352-0163-00
-153	352-0164-00			1	.	CONN BODY, PL, EL: 6 WIRE BLACK					80009	352-0164-00
	352-0402-00			1	.	HLD, ELEC CMPNT: W/4 TERMINALS, PLASTIC					25088	C61035-A14-B20
	343-0549-00			4	.	STRAP, TIEDOWN: 0.091 W X 3.62 INCH LONG					59730	TY100

+

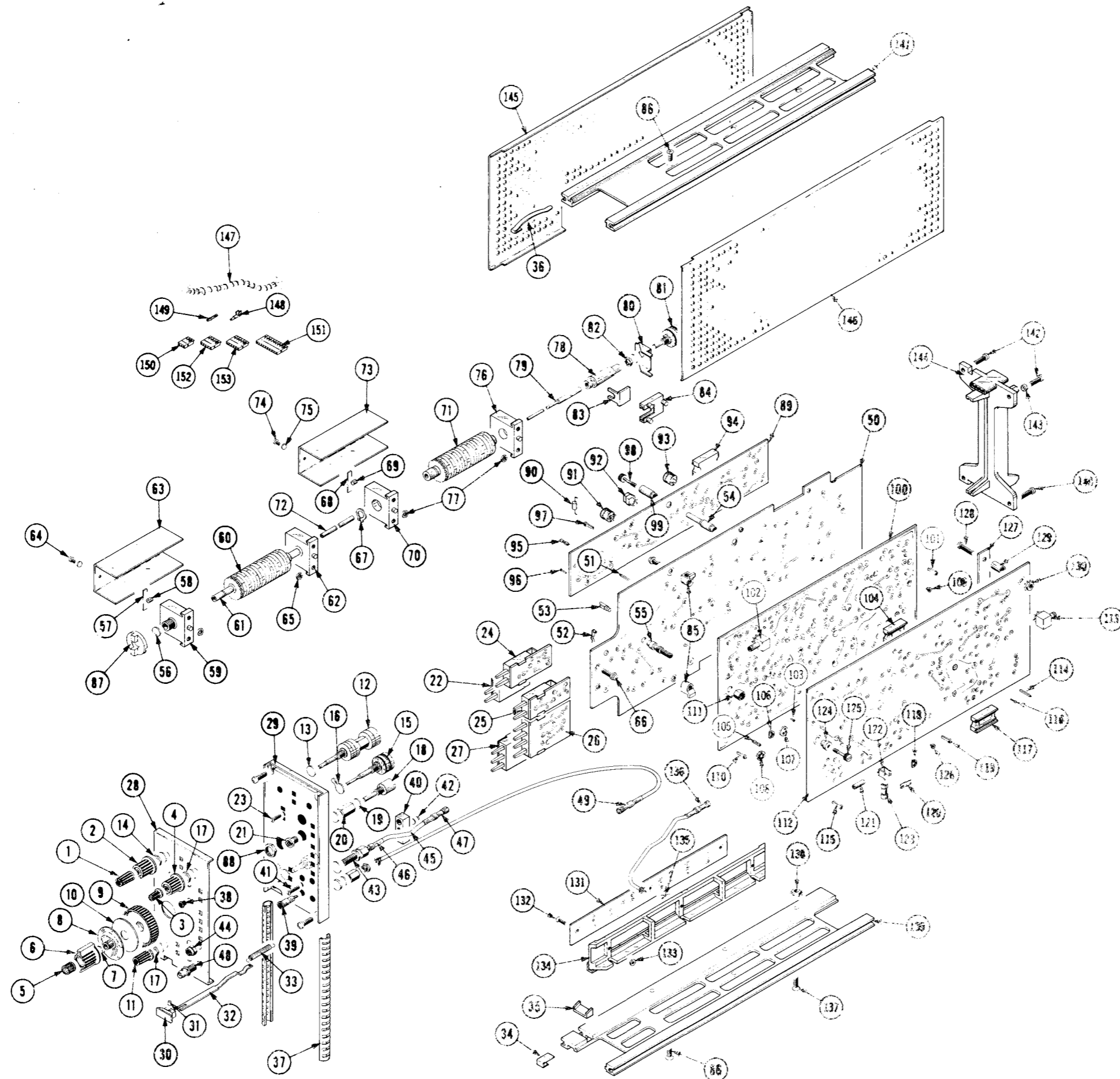
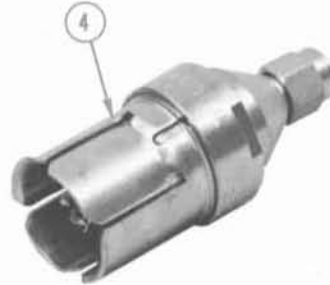

FIG. 1 EXPLODED

7T11 SAMPLING SWEEP UNIT

® +

+



Ⓐ+

FIG. 2 ACCESSORIES

Fig. & Index No.	Tektronix Part No.	Serial/Model No. Eff	Disc	Q t y						Description
					1	2	3	4	5	
2-1	011-0059-01			1						ATTENUATOR, 50 Ω, 10X, 2 W, BNC
-2	012-0057-01			1						CABLE ASSEMBLY, coaxial, 50 Ω
-3	015-1018-00			1						ADAPTER, connector, 3 mm male to BNC female
-4	015-1007-00			1						ADAPTER, connector, 3 mm male to GR
	070-0986-00			1						MANUAL, instruction (not shown)

Ⓑ

7T11 SAMPLING SWEEP UNIT

Scans by Outsource-Options =>

MANUAL CHANGE INFORMATION

At Tektronix, we continually strive to keep up with latest electronic developments by adding circuit and component improvements to our instruments as soon as they are developed and tested.

Sometimes, due to printing and shipping requirements, we can't get these changes immediately into printed manuals. Hence, your manual may contain new change information on following pages.

A single change may affect several sections. Sections of the manual are often printed at different times, so some of the information on the change pages may already be in your manual. Since the change information sheets are carried in the manual until ALL changes are permanently entered, some duplication may occur. If no such change pages appear in this section, your manual is correct as printed.

Date: 4-14-82Change Reference: C12/482Product: 7T11 SAMPLING SWEEP UNITManual Part No.: 070-0986-00

DESCRIPTION

CHANGE TO:

- ✓ Page 5-16, step 14, last line. Change to a S-4 Sampling Head.
- ✓ Page 5-17, step 14, first line. Change to a Type 284 Pulse Generator.
- ✓ Page 5-1, Item number 3. Change to a type S-4 Sampling Head.
- ✓ Page 5-2, Item Number 12. Change to a Type ²⁸⁴~~248~~ Pulse Generator.