

TEKTRONIX®

**7B70
TIME BASE**

SN B205000 AND UP

INSTRUCTION MANUAL

Tektronix, Inc.
P.O. Box 500
Beaverton, Oregon 97005

Serial Number _____

Scans By *Artek Media*

Artek Media
1042 Plummer Cir. SW
Rochester, MN 55902

www.artekmedia.com

“High resolution scans of obsolete technical manuals”

If you are looking for a quality scanned technical manual in PDF format please visit our WEB site at www.artekmedia.com or drop us an email at manuals@artekmedia.com and we will be happy to email you a current list of the manuals we have available.

If you don't see the manual you need on the list drop us a line anyway we may still be able to point you to other sources. If you have an existing manual you would like scanned please write for details, This can often be done very reasonably in consideration for adding your manual to our library.

Typically the scans in our manuals are done as follows;

- 1) Typed text pages are typically scanned in black and white at 300 dpi.
- 2) Photo pages are typically scanned in gray scale mode at 600 dpi
- 3) Schematic diagram pages are typically scanned in black and white at 600 dpi unless the original manual had colored high lighting (as is the case for some 70's vintage Tektronix manuals).

If you purchased this manual from us (typically through our Ebay name of ArtekMedia) thank you very much. If you received this from a well-meaning “friend” for free we would appreciate your treating this much like you would “share ware”. By that we mean a donation of at least \$5-10 per manual is appreciated in recognition of the time (a manual can take as much as 40 hours to reproduce, book, link etc.), energy and quality of effort that went into preserving this manual. Donations via PayPal go to: manuals@artekmedia.com or can be mailed to us the address above.

Thanks



Dave & Lynn Henderson
Artek Media



WARRANTY

All TEKTRONIX instruments are warranted against defective materials and workmanship for one year. Any questions with respect to the warranty should be taken up with your TEKTRONIX Field Engineer or representative.

All requests for repair and replacement parts should be directed to the TEKTRONIX Field Office or representative in your area. This will assure you the fastest possible service. Please include the instrument Type Number or Part Number and Serial Number with all requests for parts or service.

Specifications and price change privileges reserved.

Copyright © 1973 by Tektronix, Inc., Beaverton, Oregon. Printed in the United States of America. All rights reserved. Contents of this publication may not be reproduced in any form without permission of Tektronix, Inc.

U.S.A. and Foreign TEKTRONIX products covered by U.S. and foreign patents and/or patents pending.

TEKTRONIX is a registered trademark of Tektronix, Inc.

TABLE OF CONTENTS

SECTION 1	SPECIFICATIONS	Page
	Introduction	1-1
	Electrical Characteristics	1-1
	Sweep Rate	1-1
	Sweep Accuracy	1-1
	Sweep Length	1-1
	Sweep Hold-Off Time	1-1
	External Horizontal Amplifier	1-1
	Deflection Factor	1-1
	Frequency Response	1-2
	Trigger Sensitivity	1-2
	Internal Trigger Jitter	1-2
	External Trigger Input	1-2
	P-P Auto Sensitivity	1-2
	Environmental Characteristics	
	Altitude	1-2
	Physical Characteristics	
	Finish	1-2
	Dimensions	1-2
	Weight	1-2
SECTION 2	OPERATING INSTRUCTIONS	
	General	2-1
	Installation	2-1
	Front Panel Controls	2-1
	Test Setup Chart	2-4
	General Operating Information	2-4
	Sweep Calibration Check	2-4
	Simplified Operating Instructions	2-4
	Normal Sweep	2-6
	Magnified Sweep	2-6
	Delayed Sweep	2-6
	Pushbutton Switch Logic	2-6
	Triggered Light	2-6
	Trigger Mode	2-7
	Trigger Coupling	2-8
	Trigger Source	2-9
	Trigger Slope	2-10
	Trigger Level	2-10
	Horizontal Sweep Rate	2-10
	Sweep Magnifier	2-12
	Horizontal Position Control	2-12
	Display Mode	2-12

TABLE OF CONTENTS (cont)

SECTION 2	OPERATING INSTRUCTIONS (cont)	Page
	Applications	2-13
	General	2-13
	Frequency Comparison	2-13
	Time Duration Measurements	2-14
	Determining Frequency	2-15
	Risetime Measurements	2-15
	Delayed Sweep Time Measurements	2-16
	Delayed Sweep Magnification	2-17
	Displaying Complex Signals Using Delayed Sweep	2-18
	Pulse Jitter Measurements	2-18
	X-Y Phase Measurements	2-19
SECTION 3	CIRCUIT DESCRIPTION	
	Introduction	3-1
	Block Diagram Description	3-1
	Detailed Circuit Description	3-1
	Trigger Input	3-1
	Trigger Amplifier	3-2
	Input Stage	3-3
	Peak Detector	3-3
	Slope Comparator	3-4
	Output Stage	3-4
	Trigger Generator	3-4
	Trigger Pulse Generator	3-4
	Sweep Gate Stage	3-4
	Triggered Hold-Off Stage	3-5
	Bright Line Auto	3-5
	External Horizontal Amplifier	3-5
	Time-Base Generator	3-6
	General	3-6
	Normal Trigger Mode Operation	3-7
	Single Sweep Operation	3-8
	Alternate Operation	3-8
	Delayed Sweep Operation	3-9
	Horizontal Preamp	3-9
	Readout Block	3-9
SECTION 4	MAINTENANCE	
	Preventive Maintenance	4-1
	General	4-1
	Cleaning	4-1
	Visual Inspection	4-1
	Transistor Checks	4-1
	Recalibration	4-1

TABLE OF CONTENTS (cont)

SECTION	CONTENTS	Page
SECTION 4	MAINTENANCE (cont)	
	Troubleshooting	4-2
	Troubleshooting Aids	4-2
	Troubleshooting Equipment	4-3
	Troubleshooting Techniques	4-3
	Corrective Maintenance	4-5
	Obtaining Replacement Parts	4-5
	Soldering Techniques	4-6
	Component Replacement	4-6
	Instrument Repackaging	4-8
SECTION 5	PERFORMANCE CHECK/CALIBRATION	
	Introduction	5-1
	Test Equipment Required	5-1
	Short Form Procedure	5-2
	Performance Check/Calibration Procedure	5-4
	General	5-4
	Preliminary Control Settings	5-4
	Check/Adjust Steps (refer to Short-Form Procedure for index to steps)	5-5
SECTION 6	ELECTRICAL PARTS LIST	
	Abbreviations and Symbols	
	Parts Ordering Information	
	Index of Electrical Parts List	
SECTION 7	DIAGRAMS	
SECTION 8	MECHANICAL PARTS LIST	

CHANGE INFORMATION

Abbreviations and symbols used in this manual are based on or taken directly from IEEE Standard 260 "Standard Symbols for Units", MIL STD-12B and other standards of the electronics industry. Change information, if any, is located at the rear of this manual.

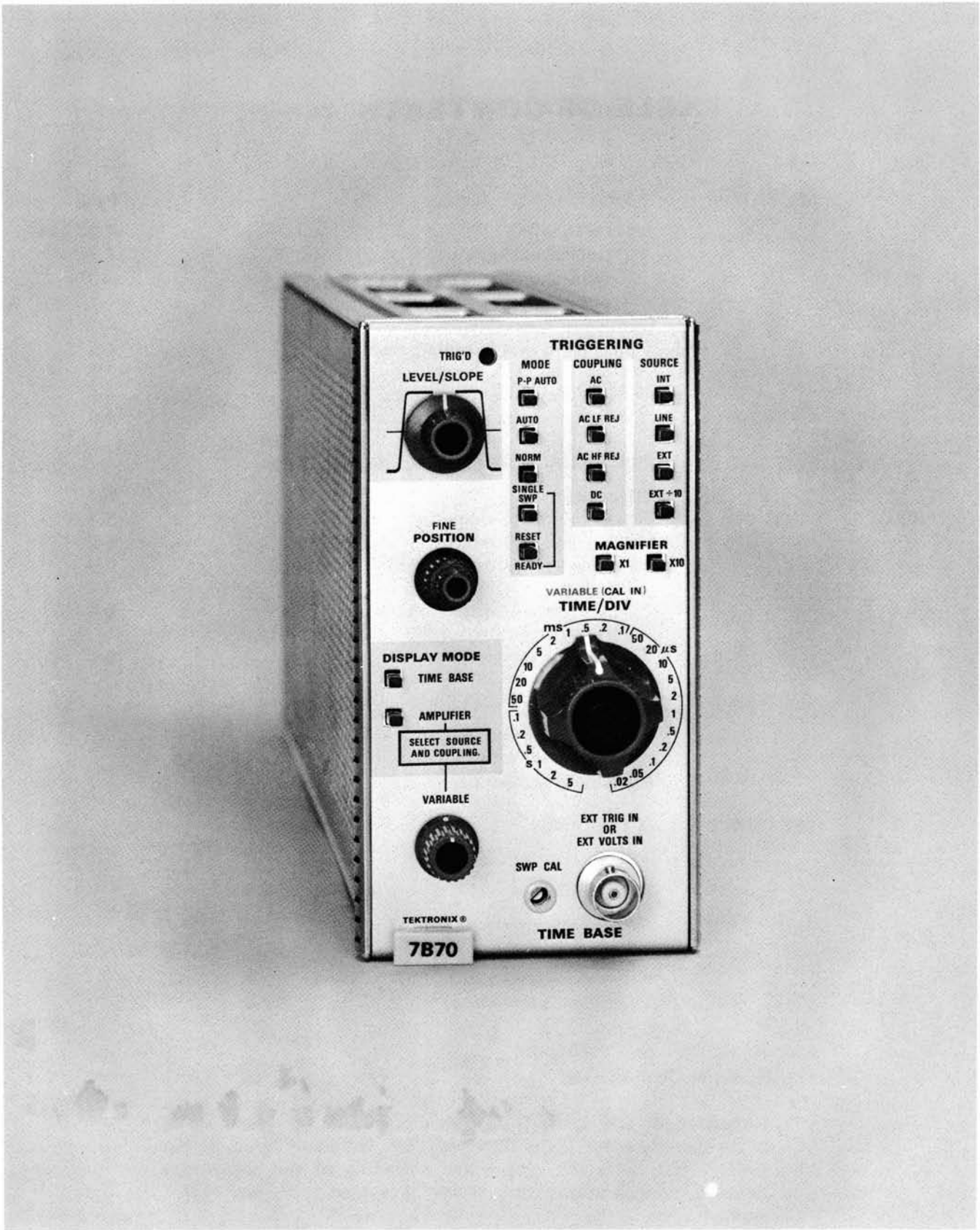

Fig. 1-1. 7B70 Time Base.

7B70 (SN B205000 and Up)

A

SECTION 1

7B70 SPECIFICATION

Change information, if any, affecting this section will be found at the rear of the manual.

Introduction

The 7B70 Time Base Unit is designed specifically for use with Tektronix 7700-series oscilloscopes. However, it is compatible with all 7000-series oscilloscopes. The 7B70 provides calibrated sweeps from 5 seconds/division to 0.02 microsecond/division. The X10 MAGNIFIER extends the calibrated sweep to 2 nanoseconds/division. Sweep rates may be varied continuously (uncalibrated) between calibrated steps. Sweep triggering is to 200 megahertz or vertical amplifier bandwidth, whichever is less. The 7B70 features an external horizontal amplifier to display signals applied to

the EXT VOLTS IN connector. The sweep free-runs to provide a bright base line in the absence of adequate triggering signal in P-P AUTO and AUTO triggering modes.

The Performance Check Procedure given in Section 5 provides a convenient method of checking performance of this instrument. The following electrical characteristics apply at an ambient temperature of 0°C to +50°C, unless otherwise noted. Warmup time for given accuracy is 20 minutes.

TABLE 1-1
ELECTRICAL CHARACTERISTICS

Characteristic	Performance				
Sweep Rate	Calibrated Range				
	5 seconds/division to 0.02 microsecond/division in a 1-2-5 sequence. X10 magnifier extends sweep rate to 2 nanoseconds/division.				
VARIABLE Range (uncalibrated)	Continuously variable between calibrated sweep rates. Extends uncalibrated sweep rate to at least 12.5 seconds/division.				
Sweep Accuracy	Measured in 7000 series mainframe.				
Time Interval	+15°C to +35°C		0°C to +50°C		
	Over Center 8 div	Unmag	Mag	Unmag	Mag
	5 s/div to 0.1 s/div and 0.2 μs/div to 0.02 μs/div	3%	3.5%	4%	5%
	50 ms/div to 0.5 μs/div	2%	2.5%	3%	4%
Over any 2 div interval within center 8 div	5%		7%		

Characteristic	Performance	
Excluded Divisions of Magnified Sweep	Start of Sweep; 12 ns in 7900 series, 20 ns in 7704A, 50 ns in other 7000 series mainframes. End of Sweep; beyond the 90th division	
Sweep Length	10.0 divisions to 13 divisions.	
Sweep Hold-Off Time	5 s/div to 5 μs/div	1.5 times the TIME/DIVISION setting or less.
	2 μs/div to 0.02 μs/div	3.5 microseconds or less.
External Horizontal Amplifier	Deflection Factor	25 millivolts/division within 5 millivolts/division.
	EXT VARIABLE Fully Clockwise	
	EXT ÷ 10 VARIABLE Fully Clockwise	250 millivolts/division within 50 millivolts/division.
	VARIABLE Range	At least 10:1

TABLE 1-1 (cont)

Characteristic	Performance		
Nominal Frequency Response	System -3 dB points in 7700-series oscilloscope.		
	Lower -3 dB	Upper -3 dB	
AC, AC LF REJ, AC HF REJ	16 hertz	100 kilohertz	
DC	-----	100 kilohertz	
Trigger Sensitivity	Triggering Frequency Range ¹	Minimum Triggering Signal Required	
		INT	EXT
Coupling AC	30 Hz to 20 MHz	0.3 div	75 mV
	20 MHz to 200 MHz	1.5 div	375 mV
AC LF REJ ²	30 kHz to 20 MHz	0.3 div	75 mV
	20 MHz to 200 MHz	1.5 div	275 mV
AC HF REJ	30 Hz to 50 kHz	0.3 div	75 mV
DC	DC to 20 MHz	0.3 div	75 mV
	20 MHz to 200 MHz	1.5 div	375 mV

¹ On Internal Triggering Only; the specified upper -3 dB frequency of the Vertical System replaces upper limit frequencies in the above table when the number in the table is greater than the -3 dB frequency of the Vertical System.

² Will not trigger on sine waves of 3 divisions or less internal or 1.5 volts external below 120 Hz.

Single Sweep	Triggering requirements same as normal sweep. When triggered, sweep generator produces one sweep only.		
Internal Trigger Jitter	1 nanosecond or less at 150 megahertz.		

TABLE 1-1 (cont)

Characteristic	Performance
External Trigger Input	
Maximum Input Voltage	500 volts (DC + Peak AC). 500 volts (P-P AC) at 1 kilohertz or less.
Input R and C	1 megohm within 2%, 20 picofarads within 2 picofarads.
Level Range (Excluding P-P AUTO)	
EXT	At least +1.5 volts to -1.5 volts.
EXT ÷ 10	At least +15 volts to -15 volts.
P-P AUTO Operation	
Sensitivity	0.5 div Internal, 125 millivolts External, 200 Hz to 20 MHz. Upper frequency and amplitude limits same as NORMAL Trigger Sensitivity.
Low Frequency Response	Must Trigger on 50 hertz, 2 division signal.

TABLE 1-2

ENVIRONMENTAL CHARACTERISTICS

This instrument will meet the electrical characteristics given in Table 1-1 over the following environmental limits.

Characteristic	Performance
Altitude	
Non-operating	To 50,000 feet and -55°C.

TABLE 1-3

PHYSICAL CHARACTERISTICS

Characteristic	Performance
Finish	Front panel is anodized aluminum.
Dimensions	14.583 inches long by 2.75 inches wide by 5 inches high.
Weight	Approximately 2.88 pounds.

SECTION 2

OPERATING INSTRUCTIONS

Change information, if any, affecting this section will be found at the rear of the manual.

General

The 7B70 plug-in unit operates with a Tektronix 7000-series indicator oscilloscope and a 7A-series vertical plug-in unit to form a complete oscilloscope system. To effectively use the 7B70 its operation and capabilities should be known. This section describes the operation of the front-panel controls, gives first-time and general operating information and lists some basic applications for this instrument.

Installation

The 7B70 is designed to operate in the horizontal plug-in compartments of Tektronix 7000-series oscilloscopes. The 7B70 can also be installed in a vertical plug-in compartment to provide a sweep that runs vertically on the CRT. However, when used in this manner, there is no retrace blanking or internal triggering provision and the unit may not meet the specifications given in Section 1. The instructions in this manual are written for use of the 7B70 in a horizontal plug-in compartment of the oscilloscope.

When the 7B70 is used with an oscilloscope which has two horizontal plug-in compartments, install this unit in the B (right) compartment. Then, if a delaying-sweep unit is installed in the A (DELAYING TIME BASE) compartment, delayed-sweep operation is available. The 7B70 will operate

properly in the A compartment for all horizontal modes of operation except delaying sweep.

To install the 7B70 into a plug-in compartment, push it in until it fits firmly into the indicator plug-in compartment. To remove, pull the release latch (see Fig. 2-1) to disengage the unit from the indicator and pull it out of the plug-in compartment. Even though the horizontal gain of the indicator oscilloscope is standardized to minimize adjustment when inserting plug-in units, the sweep calibration of the 7B70 should be checked when it is inserted into the indicator to verify measurement accuracy. The procedure for checking the unit is given under Sweep Calibration Check in this section.

FRONT-PANEL CONTROLS

General

All controls required for the operation of the 7B70 are located on the front panel of the unit (see Fig. 2-2). To make full use of the capabilities of this instrument, the operator should be familiar with the function and use of each of these controls. A brief description of the front-panel controls and connector is given here. More detailed information is given under General Operating Information.

Triggering Controls

LEVEL/SLOPE

Selects the amplitude point and slope of trigger signal on which the sweep is triggered. When the indicator line on the outer ring is to the left of center, the sweep is triggered on the positive-going slope of the trigger signal, as shown by the positive-going waveform. To the right of center, the sweep is triggered on the negative-going slope of the trigger signal as shown by the negative-going waveform.

TRIG'D

Light indicates that the sweep is triggered and will produce a display with correct setting of the POSITION control and the controls on the associated vertical unit and indicator oscilloscope.

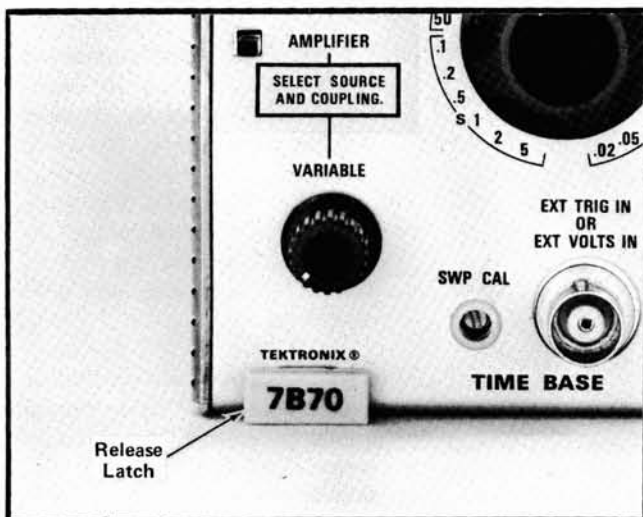

Fig. 2-1. Location of release latch.

MODE

Series of push-button switches to select the trigger mode. Selected mode is indicated by lighted button.

P-P AUTO: Sweep automatically triggered at point selected by the LEVEL/SLOPE control when the trigger signal repetition rate is above about 200 hertz and within the frequency range selected by the COUPLING switch. Triggered sweep can be obtained throughout the entire range of the LEVEL/SLOPE control. When the trigger repetition rate is below the lower frequency limit (or above upper limit for AC HF REJ) or when the trigger signal is inadequate, the sweep free runs at the sweep rate selected by the TIME/DIV switch to produce a reference trace.

AUTO: Sweep initiated by the applied trigger signal at point selected by the LEVEL/SLOPE control when the trigger signal repetition rate is above about 30 hertz and within the frequency range selected by the COUPLING switch. Triggered sweep can be obtained only over the amplitude range of the applied trigger signal. When the LEVEL/SLOPE control is outside the amplitude range, the trigger repetition rate is below the lower frequency limit (or above upper limit for AC HF REJ) or the trigger signal is inadequate, the sweep free runs at the sweep rate selected by the TIME/DIV switch to produce a reference trace.

NORM: Sweep initiated by the applied trigger signal at any point selected by the LEVEL/SLOPE control over the frequency range selected by the COUPLING switch. Triggered sweep can be obtained only over the amplitude range of the applied trigger signal. When the LEVEL/SLOPE control is outside the amplitude range, the trigger repetition rate is outside the frequency range selected by the COUPLING switch or the trigger

signal is inadequate, there is no trace.

SINGLE SWP: Sweep initiated by the applied trigger signal at any point selected by the LEVEL/SLOPE control over the frequency range selected by the COUPLING switch. Triggered sweep can be obtained only over the amplitude range of applied trigger signal. After the first sweep is displayed, further sweeps cannot be presented until the RESET-READY push-button is pressed. When the LEVEL/SLOPE control is outside the amplitude range, the trigger repetition rate is outside the frequency range selected by the COUPLING switch, the trigger signal is inadequate or when the RESET-READY light is off, there is no trace.

RESET-READY: Push-button to reset the Sweep Generator for the next sweep in the single-sweep mode. The RESET-READY button remains lighted to indicate that the unit is ready to be triggered. After the unit is triggered and a sweep is completed, the RESET-READY light goes out until the button is pressed again.

COUPLING

Series of push-button switches to select the trigger coupling. Selected coupling is indicated by lighted button.

AC: Rejects DC and attenuates AC signals below about 30 hertz. Accepts signals between 30 hertz and 200 megahertz.

AC LF REJ: Rejects DC and attenuates signals below about 30 kilohertz. Accepts signals between 30 kilohertz and 200 megahertz.

AC HF REJ: Accepts signals between about 30 hertz and 50 kilohertz. Rejects DC and attenuates signals outside this frequency range.

DC: Accepts all trigger signals from DC to 200 megahertz.

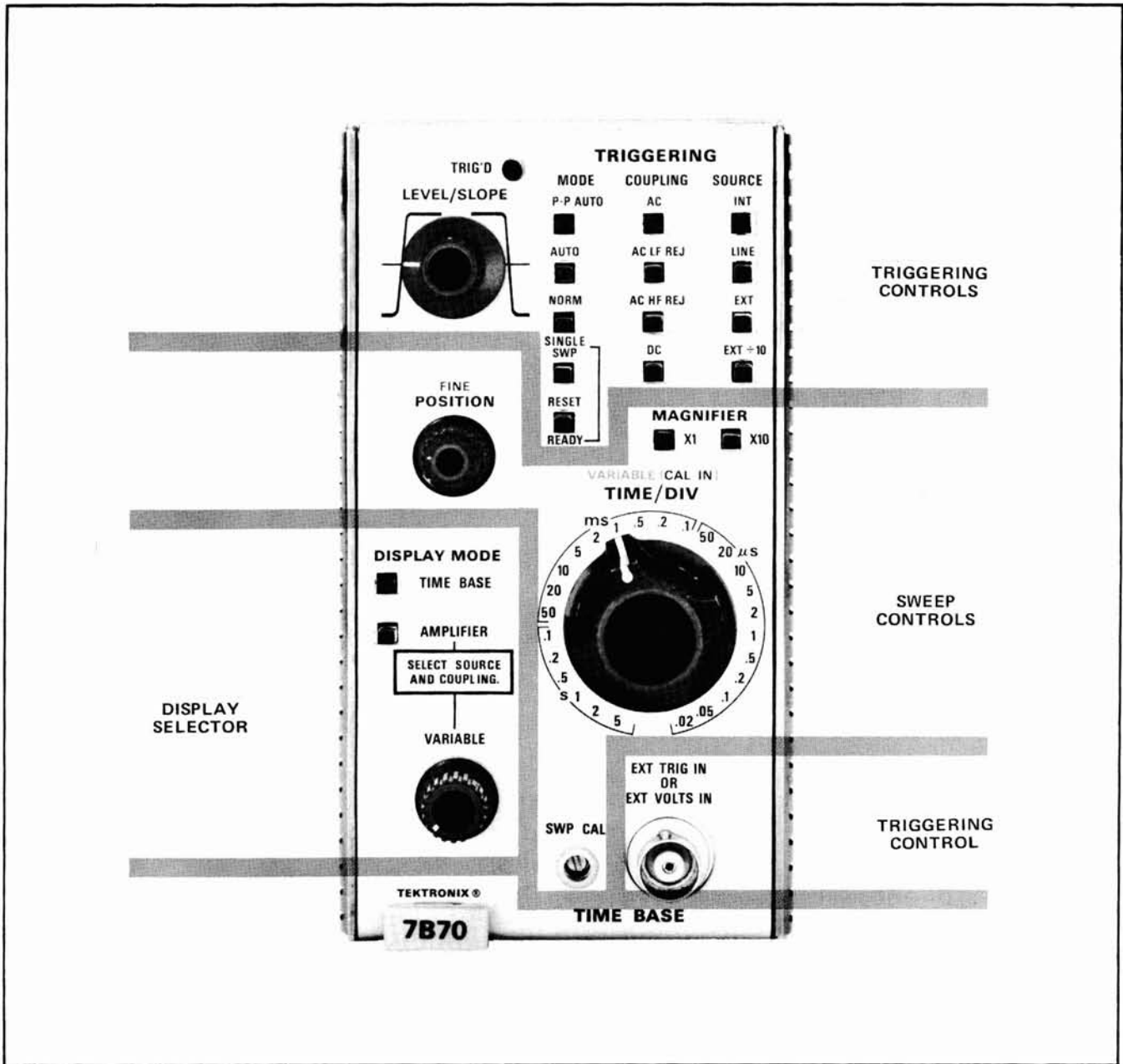

Fig. 2-2. Front-Panel controls and connectors.

SOURCE

Series of push-button switches to select the trigger source. Selected source is indicated by lighted button.

INT: Trigger signal obtained internally from a vertical unit.

LINE: Trigger signal obtained internally from a sample of the line voltage applied to this instrument.

EXT: Trigger signal obtained from an external signal applied to the EXT TRIG IN connector.

EXT ÷ 10: Trigger signal obtained from an external signal applied to the EXT TRIG IN connector as in the EXT position. In this position the external signal is attenuated 10 times before it is applied to the trigger circuit.

EXT TRIG IN or EXT VOLTS IN

Input connector for external trigger signal or amplifier input signal.

Operating Instructions—7B70 (SN B205000 and Up)

Sweep Controls

POSITION	Controls horizontal position of display.
FINE	Provides more precise control of horizontal positions.
TIME/DIV	Selects the basic sweep rate of the output sawtooth. The VARIABLE control must be in calibrated position and MAGNIFIED switch set to X1 for indicated sweep rate.
VARIABLE (TIME/DIV)	Two-position switch actuated by the VARIABLE knob to select calibrated or uncalibrated sweep rates. At the in position, the VARIABLE control is inoperative and the sweep rate is calibrated. When pressed and released, the knob moves out to activate the VARIABLE control for uncalibrated sweep rates. The sweep rate in each TIME/DIV switch position can be reduced to at least the sweep rate of the next adjacent position, to provide continuously variable sweep rates from 2 nanoseconds/division (X10-MAGNIFIER on) to about 12.5 seconds/division, with MAGNIFIER at X1.
MAGNIFIED	Push-button switches to select the horizontal magnification. The Selected magnification is indicated by a lighted button. X1: Magnified sweep at the basic sweep rate indicated by TIME/DIV switch. X10: Magnified sweep at a sweep rate 10 times faster than the basic sweep rate indicated by the TIME/DIV switch. The portion of the normal sweep within the center division of the graticule is the portion shown in magnified form.
SWP CAL	Screwdriver adjustment to set amplitude of the output sawtooth.

Display Mode	
TIME BASE	Selects sweep rates as determined by TIME/DIV switch.
AMPLIFIER	Displays signals applied to the EXT TRIG IN or EXT VOLTS IN connec-

tor. Select TRIGGERING SOURCE and COUPLING.

VARIABLE (amplifier) Varies deflection factor by a factor of 10.

TEST SETUP CHART

General

Fig. 2-3 shows the front panel of the 7B70. This chart can be reproduced and used as a test-setup record for special measurements, applications or procedures, or it may be used as a training aid for familiarization with this instrument.

GENERAL OPERATING INFORMATION

Sweep Calibration Check

Whenever the 7B70 is inserted into a plug-in compartment other than the one in which it was calibrated, the sweep calibration should be checked and readjusted if necessary. Allow five minutes warmup before performing this procedure.

NOTE

For accurate sweep timing, apply a signal of known frequency or time period (time-mark signal, calibrator square wave, 60 hertz line etc.) to the associated vertical amplifier unit and adjust the TIME/DIV OR DLY TIME switch and the SWP CAL control to calibrate the signal to the oscilloscope graticule. Be sure that the sweep timing signal is accurate within 0.5%. The following sweep calibration procedure uses a Tektronix Time-Mark Generator.

1. Connect a 1 millisecond time-mark signal from the Time-Mark Generator with a 50-ohm BNC coaxial cable and 50-ohm BNC termination to the Input of the associated vertical unit.
2. Set the TIME/DIV switch to 1 ms and press the top TRIGGERING and DISPLAY MODE pushbuttons.
3. Set the Vertical unit to display at least two divisions of the signal vertically.
4. Check the CRT display for one complete cycle per division.
5. If necessary, adjust the SWP CAL adjustment for one complete cycle per division.

Simplified Operating Instructions

The following information is provided to aid in quickly obtaining the correct settings for the 7B70 to present a

7B70 TEST SET-UP CHART

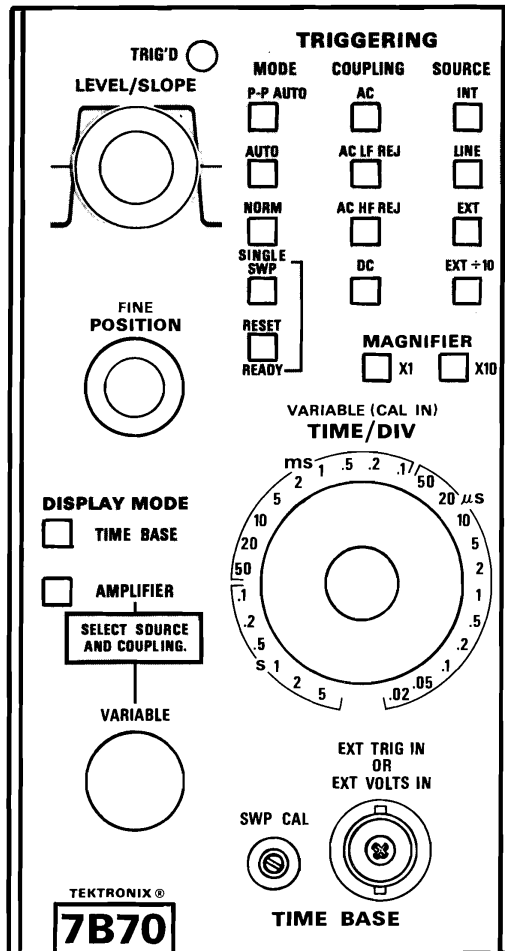

NOTES:

Fig. 2-3. 7B70 Test Setup Chart.

Operating Instructions—7B70 (SN B205000 and Up)

display. The operator should be familiar with the complete function and operation of the unit as described in this section before using this procedure.

Normal Sweep. The following procedure will provide a stable display for most normal-sweep applications.

1. Select the TRIGGERING MODE, COUPLING and SOURCE which fit the requirements of the signal to be displayed.

2. Turn the LEVEL/SLOPE control to the desired slope.

3. If the green TRIG'D light is not on, adjust the LEVEL/SLOPE control throughout the range of the selected slope until the TRIG'D light comes on. If the light does not come on at any setting of the LEVEL/SLOPE control, the trigger signal is inadequate or the COUPLING and SOURCE switches are set incorrectly.

4. Set the TIME/DIV switch and POSITION control for a display which remains on the display area horizontally (VARIABLE control should be in CAL position for calibrated sweep rates).

5. If the display does not start at the correct point on the waveform, readjust the LEVEL/SLOPE control for the desired triggering.

Magnified Sweep. A magnified-sweep display can be obtained as follows after a normal-sweep display is obtained as given in steps 1-5 above.

1. Adjust the POSITION control to move the area to be magnified within the center division of the CRT.

2. If necessary, change the TIME/DIV switch setting so the complete area to be magnified is within the center division.

3. Press the X10-MAGNIFIER push-button.

4. Use the fine range of the POSITION control to establish precise positioning of the magnified display.

Delayed Sweep. The following procedure can be used to obtain a delayed-sweep display when the 7B70 is used in an

oscilloscope that has dual time base capabilities and when used with a companion delaying-sweep unit (A). Obtain a display as given in steps 1-5 under Normal Sweep. Then proceed as follows:

1. Press the B STARTS AFTER DELAY push-button on the A time-base.

2. Set the indicator oscilloscope horizontal mode to display the A time base.

3. Set the TIME/DIV switch of the 7B70 so the intensified zone on the display is the desired length (intensified zone will be displayed in delayed form). If the intensified zone is not visible, adjust the indicator intensity controls.

4. Adjust the A time-base DELAY TIME MULT dial to position the intensified zone to the portion of the display to be delayed.

5. Set the indicator oscilloscope horizontal mode to display the B time base (7B70).

6. If a delayed sweep with less jitter is desired, press the A time-base B TRIGGERABLE AFTER DELAY push-button. The triggering controls of the 7B70 must be set to obtain a stable display.

Pushbutton Switch Logic

The TRIGGERING MODE, COUPLING and SOURCE switches and the DISPLAY MODE switch are arranged in a sequence which places the most often-used position at the top of each series of pushbuttons. With this arrangement, a stable normal-sweep display can usually be obtained by pressing the top push-buttons; P-P AUTO, AC, INT and TIME BASE. When an adequate trigger signal is applied, the unit is triggered as indicated by the illuminated TRIG'D light at any setting of the LEVEL/SLOPE control. If the TRIG'D light is not on, either the trigger signal applied to this unit from the vertical unit is inadequate or it is below the lower frequency limit of the AC COUPLING switch position. If the desired display is not obtained with the pushbuttons pushed in, other selections must be made. Refer to the following discussions or the instruction manuals for the associated indicator oscilloscope and vertical unit for more information.

Triggered Light

The TRIG'D light provides a convenient indication of the condition of the triggering circuits. If the TRIGGERING controls are correctly set and an adequate trigger

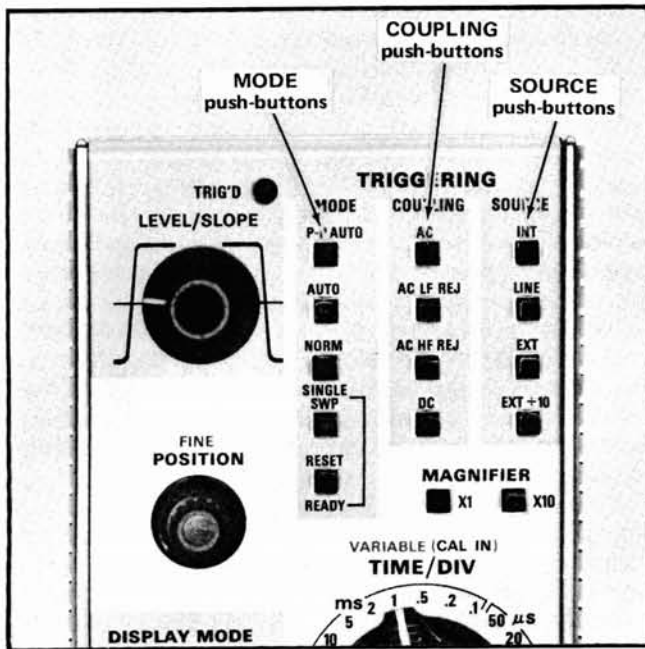

Fig. 2-4. Exploded view of front panel showing push-buttons associated with the MODE, COUPLING and SOURCE switches.

Trigger Mode

The pushbuttons located under the MODE title (see Fig. 2-4) select the mode in which the sweep is triggered. The selected mode is indicated by a lighted pushbutton.

P-P AUTO. When the P-P AUTO pushbutton is pressed, a triggered display is provided at any setting of the LEVEL/SLOPE control whenever an adequate trigger signal is applied. The range of the LEVEL/SLOPE control in this mode is between about 10% and 90% of the peak-to-peak amplitude of the applied trigger signal. The LEVEL/SLOPE control can be set so the displayed waveform starts at any point within this range on either slope. In the P-P AUTO mode, the trigger circuit automatically compensates for changes in trigger signal amplitude for signals above the minimum amplitude requirement. Therefore, if the LEVEL/SLOPE control is set so the displayed waveform starts at a certain percentage-point on the leading edge of a low-amplitude signal, it triggers at the same percentage-point on the leading edge of a high-amplitude signal if the LEVEL/SLOPE control is not changed. This operation is illustrated in Fig. 2-5.

signal is applied, the TRIG'D light is on. Under certain conditions, the TRIG'D light may be off, indicating that the sweep is not triggered. The cause might be a misadjusted LEVEL/SLOPE control, incorrectly set COUPLING or SOURCE switches, low trigger signal amplitude, or a trigger signal repetition rate outside the acceptable frequency range. This feature can be used as a general indication of correct triggering. It is particularly useful when setting up the trigger circuits when a trigger signal is available without a display on the CRT. It also indicates that this unit is correctly triggered when operating as a delayed-sweep unit (B).

When the trigger repetition rate is below about 200 hertz (or outside the frequency range selected by the COUPLING switch), or when the trigger signal is inadequate, the sweep free runs at the sweep rate indicated by the TIME/DIV switch to produce a reference trace (TRIG'D light off). When an adequate trigger signal is again applied, the free-running condition ends and a triggered display is presented.

The P-P AUTO trigger mode is particularly useful when observing a series of waveforms, since it is not necessary to reset the LEVEL/SLOPE control for each observation. Also, because of the ease of obtaining a triggered display in

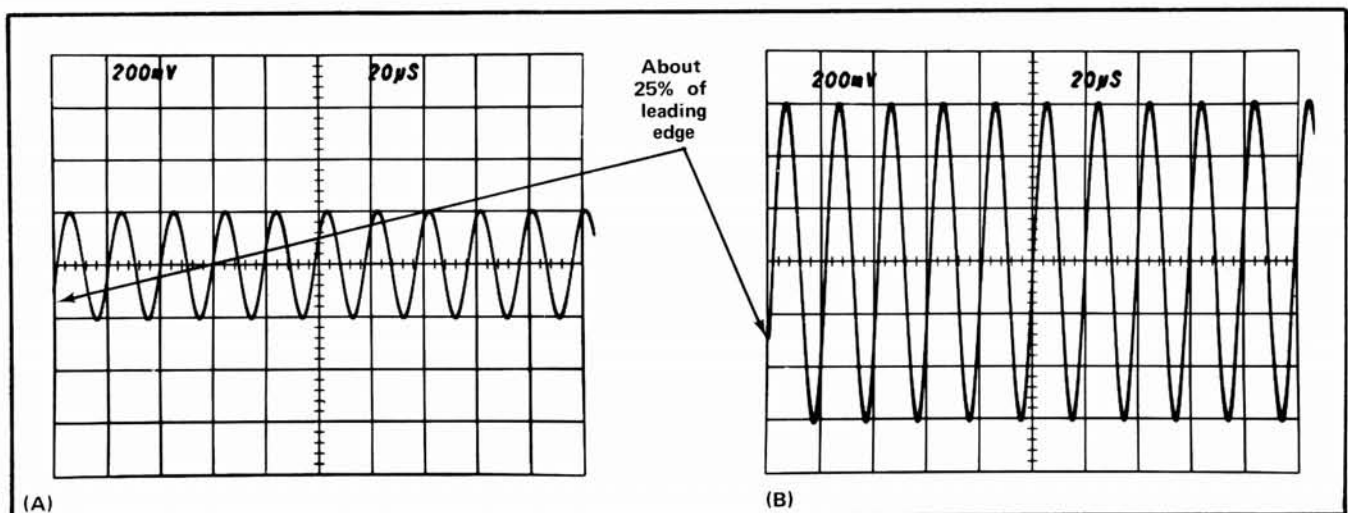

Fig. 2-5. LEVEL/SLOPE control operation for (P-P) AUTO mode triggering. (A) LEVEL/SLOPE control set so displayed waveform starts at about 25% point of a one-division waveform. (B) displayed waveform still triggered at about 25% of leading edge, when signal amplitude increases to produce an eight-division display (LEVEL/SLOPE control at same setting for both waveforms).

this mode, the P-P AUTO trigger mode can be used for most applications and the remaining modes used only for special applications or when stable triggering is not obtainable in this mode.

AUTO. When the AUTO push-button is illuminated, a triggered display is presented with the correct setting of the LEVEL/SLOPE control (see Trigger Level discussion) whenever an adequate trigger signal is applied. The range of the LEVEL/SLOPE control in this mode is ± 8 vertical divisions. The TRIG'D light indicates when the display is triggered.

When the trigger repetition rate is below about 30 hertz (or outside the frequency range selected by the COUPLING switch) or when the trigger signal is inadequate, the sweep free runs at the sweep rate indicated by the TIME/DIV switch to produce a reference trace (TRIG'D light off). When an adequate trigger signal is again applied, the free-running condition ends and a triggered display is presented. When the LEVEL/SLOPE control is at a setting outside the amplitude range of the trigger signal, the sweep also free runs at the sweep rate indicated by the TIME/DIV switch. This type of free-running display can be useful when it is desired to measure only the maximum peak-to-peak amplitude of a signal without observing the waveshape (such as in bandwidth measurements).

NORM. When the NORM push-button is pressed, a triggered display is presented with the correct setting of the LEVEL/SLOPE control whenever an adequate trigger signal is applied. The range of the LEVEL/SLOPE control in this mode is ± 8 vertical divisions. The TRIG'D light indicates when the display is triggered.

The NORM trigger mode must be used to produce triggered displays with trigger repetition rates below about 30 hertz. When the LEVEL/SLOPE control is at a setting outside the amplitude range of the trigger signal, when the trigger repetition rate is outside the frequency range selected by the COUPLING switch or when the trigger signal is inadequate, there is no trace (TRIG'D light off).

SINGLE SWP. When the signal to be displayed is not repetitive or varies in amplitude, waveshape or repetition rate, a conventional repetitive type display may produce an unstable presentation. A stable display can often be obtained under these circumstances by using the single-sweep feature of this unit. The SINGLE SWP MODE is also useful to photograph non-repetitive or unstable displays.

To obtain a single-sweep display of a repetitive signal, first obtain the best possible display in the NORM MODE. Then without changing the other TRIGGERING controls,

press the SINGLE SWP pushbutton. When ready to view the single-sweep display, press the RESET-READY pushbutton. A single trace is presented each time the RESET-READY pushbutton is pressed (as long as the repetitive signal remains connected to the system and TRIGGERING controls are correctly set) and further sweeps cannot be presented until the RESET-READY pushbutton is pressed again. If the displayed signal is a complex waveform composed of pulses of varying amplitude, successive single-sweep displays may not start at the same point of the waveform. To avoid confusion due to the CRT persistence, allow the display to decay before pressing the RESET-READY pushbutton again. At fast sweep rates, it may be difficult to view the single-sweep display. The apparent trace intensity can be increased by reducing the ambient light level or using a viewing hood as recommended in the indicator instruction manual.

Non-repetitive, random signals can be displayed in the single-sweep mode by first obtaining the best possible display in the NORM MODE with a signal which is about the same amplitude and frequency as the random signal. Then without changing the other TRIGGERING controls, press the SINGLE SWP pushbutton. When ready for the random signal, press the RESET-READY pushbutton. The RESET-READY pushbutton remains lighted to indicate that the unit has been reset and is ready to produce a sweep. The light goes out after the random signal triggers the unit. To prepare the unit for another single-sweep display, press the RESET-READY pushbutton again.

When using the single-sweep mode to photograph waveforms, the graticule must be photographed separately in the normal manner to prevent over-exposing the film. Be sure the camera system is well protected against stray light, or operate the system in a darkened room. For repetitive waveforms, press the RESET-READY pushbutton only once for each waveform unless the signal is completely symmetrical. Otherwise, multiple waveforms may appear on the film. For random signals, the camera lens can be left open until the random signal triggers the unit (RESET-READY pushbutton lighted). Further information on photographic techniques is given in the camera instruction manual.

Trigger Coupling

The pushbuttons located below the COUPLING title (see Fig. 2-4) select the method in which the trigger signal is connected to the trigger circuits. The selected coupling is indicated by a lighted pushbutton. Each position permits selection or rejection of the frequency components of the trigger signal which trigger the sweep. Fig. 2-6 graphically illustrates the band of frequencies covered by each position of the COUPLING switch.

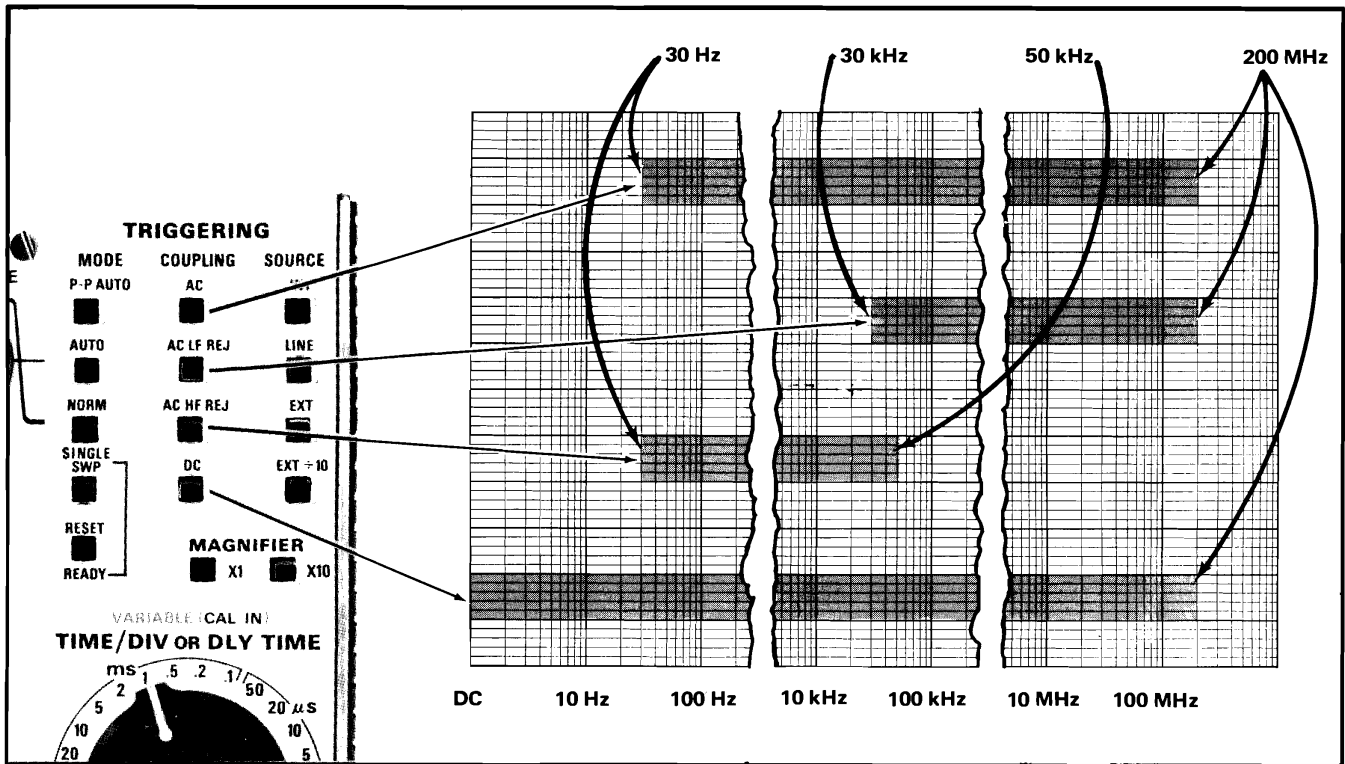

Fig. 2-6. Frequency range of each COUPLING switch position.

AC. In the AC position of the COUPLING switch, the DC component of the trigger signal is blocked. Signals with low-frequency components below about 30 hertz are attenuated. In general, AC COUPLING can be used for most applications. However, if the signal contains unwanted frequency components or if the sweep is to be triggered at a low repetition rate or DC level, one of the remaining COUPLING switch positions will provide a better display.

The triggering point in the AC position depends upon the average voltage level of the trigger signal. If the trigger signal occurs randomly, the average voltage level will vary, causing the triggering point to vary also. This shift of the triggering point may be enough so it is impossible to maintain a stable display. In such cases, use DC coupling.

AC LF REJ. In the AC LF REJ position, DC is rejected and low-frequency trigger signals below about 30 kilohertz are attenuated. Therefore, the sweep is triggered only by the higher-frequency components of the trigger signal. This position is particularly useful for providing stable triggering if the trigger signal contains line-frequency components. Also, the AC LF REJ position provides the best alternate-mode vertical displays at fast sweep rates when comparing two or more unrelated signals (with dual-trace vertical or slaved triggering operation for dual-vertical unit operation).

AC HF REJ. The AC HF REJ position passes all low-frequency signals between about 30 hertz and 50 kilohertz. DC is rejected and signals outside the above range are attenuated. When triggering from complex waveforms, this position is useful for providing stable display of the low-frequency components.

DC. DC COUPLING can be used to provide stable triggering with low-frequency signals which would be attenuated in the other modes, or with low-repetition rate signals. It can also be used to trigger the sweep when the trigger signal reaches a DC level selected by the setting of the LEVEL/SLOPE control. When using internal triggering, the setting of the vertical unit position controls affects the DC triggering point.

Trigger Source

The pushbuttons located below the SOURCE title (see Fig. 2-4) select the source of the trigger signal which is connected to the trigger circuits. The selected source is indicated by a lighted pushbutton.

INT. In the INT position of the SOURCE switch, the trigger signal is derived from the associated vertical unit. Further selection of the internal trigger signal may be pro-

vided by the associated vertical unit or indicator oscilloscope; see the instruction manuals for these instruments for information. For most applications, the INT-SOURCE position can be used. However, some applications require special triggering which cannot be obtained in the INT-SOURCE position. In such cases LINE- or EXT-SOURCE must be used.

LINE. The LINE position of the SOURCE switch connects a sample of the power-line voltage, to which the indicator oscilloscope is connected, to the trigger circuit. Line triggering is useful when the input signal is time-related (multiple or sub-multiple) to the line frequency. It is also useful for providing a stable display of a line-frequency component in a complex waveform.

EXT. An external signal connected to the EXT TRIG IN connector can be used to trigger the sweep in the EXT-SOURCE position. The external signal must be time-related to the displayed waveform for a stable display. An external trigger signal can be used to provide a triggered display when the internal signal is too low in amplitude for correct triggering or contains signal components on which it is not desired to trigger. It is also useful when signal tracing in amplifiers, phase-shift networks, wave-shaping circuits, etc. The signal from a single point in the circuit under test can be connected to the EXT TRIG IN connector through a probe or cable. The sweep is then triggered by the same signal at all times and allows amplitude, time relationship or waveshape changes of signals at various points in the circuit to be examined without resetting the TRIGGERING controls.

EXT ÷ 10. Operation in the EXT ÷ 10 position is the same as described for EXT except that the external signal is attenuated 10 times. Attenuation of high-amplitude external trigger signals is desirable to broaden the range of the LEVEL/SLOPE control.

Trigger Slope

The LEVEL/SLOPE control determines whether the trigger circuit responds on the positive-going or negative-going portion of the trigger signal. When the indicator line on the outer ring of the LEVEL/SLOPE control is to the left of center, the display starts on the positive-going portion of the waveform (notice positive-going waveform to left of control). To the right of center, the display starts on the negative-going portion of the waveform (notice negative-going waveform). The effect of the LEVEL/SLOPE control on the displayed waveform is shown in Fig. 2-7. When several cycles of a signal appear in the display, the selection of the trigger slope is often unimportant. However, if only a certain portion of a cycle is to be displayed, correct setting of the LEVEL/SLOPE control is important to provide a display which starts on the desired slope of the input signal.

Trigger Level

The LEVEL/SLOPE control determines the voltage level on the trigger signal at which the display is triggered, as well as selecting the trigger slope. The center knob of the LEVEL/SLOPE control provides about a 3:1 reduction in relation to the outer indicator ring, to allow precise level selection. This control can also be turned throughout the complete 360° rotation to allow continuous triggering over the selected slope. This is particularly useful in the P-P AUTO MODE. When the LEVEL/SLOPE control is set to the "O" on either the positive-going or negative-going waveform, the sweep is triggered near the zero-volt level of the trigger signal. As the LEVEL/SLOPE control is rotated away from the "O", the displayed waveform starts at a point corresponding to the position of the indicator line on the associated slope waveform (within amplitude range of trigger signal except in P-P AUTO MODE which provides triggered display throughout entire slope). For example if the LEVEL/SLOPE control is turned clockwise from the "O" on the positive-going slope, the displayed waveform starts at a more positive level. Fig. 2-7 illustrates the operation of the LEVEL/SLOPE control at different levels and slopes of a displayed waveform.

Before setting the triggering level, select the TRIGGERING SLOPE, MODE, COUPLING and SOURCE. Then adjust the LEVEL/SLOPE control so the displayed waveform starts at the desired point. The triggering slope can be changed at any time by rotating the LEVEL/SLOPE control to the corresponding point on the other slope waveform.

Horizontal Sweep Rate

The TIME/DIV switch provides 26 calibrated sweep rates ranging from 0.02 microsecond/division to five seconds/division. The VARIABLE TIME/DIV control must be in the calibrated position and the MAGNIFIER at X1 for the indicated sweep rate. The VARIABLE TIME/DIV control incorporates a two-position switch to determine if the sweep rate is calibrated or uncalibrated. When the VARIABLE knob is in the inward position, the VARIABLE TIME/DIV control is inoperative and the sweep rate is calibrated. When pressed and released, the VARIABLE knob moves outward to activate the VARIABLE TIME/DIV control for uncalibrated sweep rates. A calibrated sweep rate can be obtained at any position of the VARIABLE TIME/DIV control by pressing in the VARIABLE knob. This feature is useful when a specific uncalibrated sweep rate has been obtained and it is desired to switch between this uncalibrated sweep rate and a calibrated sweep rate. Switching from uncalibrated to calibrated operation or vice versa does not affect the setting of the VARIABLE TIME/DIV control. The VARIABLE TIME/DIV control allows the sweep rate in each TIME/DIV switch position to be reduced to at least the sweep rate of the next adjacent switch position. This provides an overall uncalibrated vari-

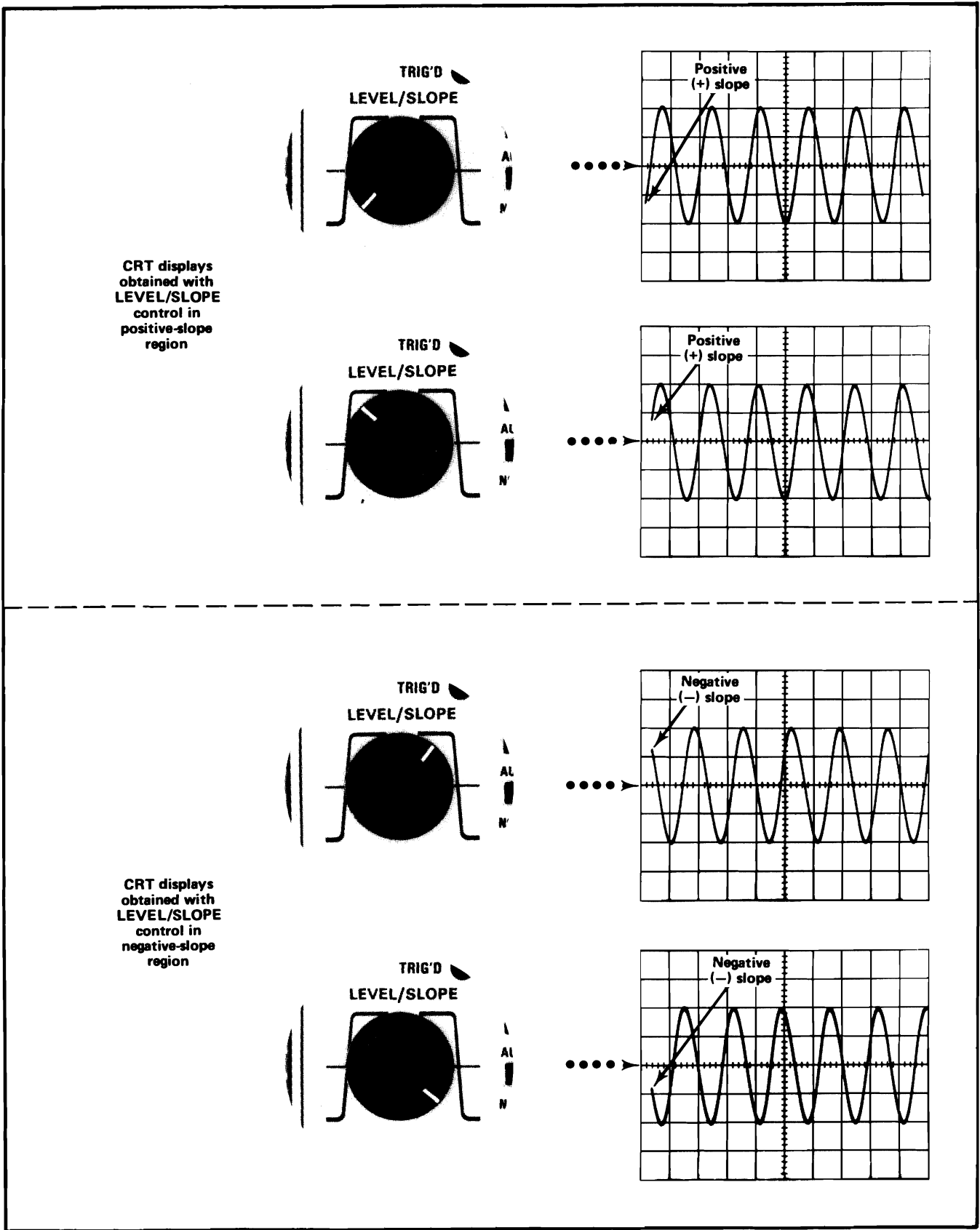

CRT displays obtained with LEVEL/SLOPE control in positive-slope region

CRT displays obtained with LEVEL/SLOPE control in negative-slope region

Fig. 2-7. Effect of LEVEL/SLOPE control on CRT display (AUTO P-P MODE).

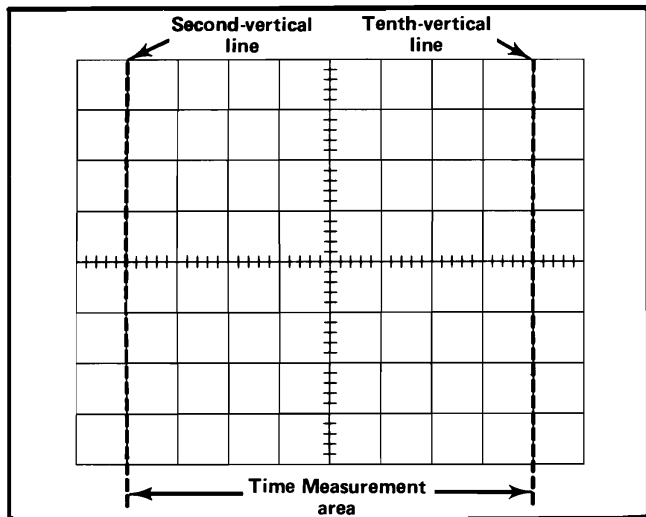

Fig. 2-8. Area of graticule used for accurate time measurements.

able sweep rate range from 20 nanoseconds/division (from 2 nanoseconds/division with MAGNIFIER at X10) to about 12.5 seconds/division.

When making time measurements from the graticule, the area between the second-division and tenth-division vertical lines of the graticule provides the most linear time measurement (see Fig. 2-8). Therefore, the first and last division of the display area should not be used when making accurate time measurements. Position the start of the timing area to the second vertical line (second line from the left) and adjust the TIME/DIV switch so the end of the timing area falls between the second-division and tenth-division vertical lines.

Sweep Magnifier

The sweep magnifier expands the sweep ten times. The center division of the unmagnified display is the portion visible on the screen in magnified form (see Fig. 2-9). Equivalent length of the magnified sweep is more than 100 divisions; any 10-division portion can be viewed by adjusting the horizontal POSITION control to bring the desired portion onto the viewing area. The dual-range feature of the horizontal POSITION control is particularly useful when the MAGNIFIER is set to X10 (see Horizontal Position Control discussion which follows).

To use sweep magnification, first move the portion of the display which is to be expanded to the center of the graticule. Then press the X10-MAGNIFIER pushbutton; the X10 button lights to indicate that the horizontal sweep rate is magnified. Whenever the X10-MAGNIFIER pushbutton is lighted, the equivalent magnified sweep rate can be determined by dividing the TIME/DIV switch setting by

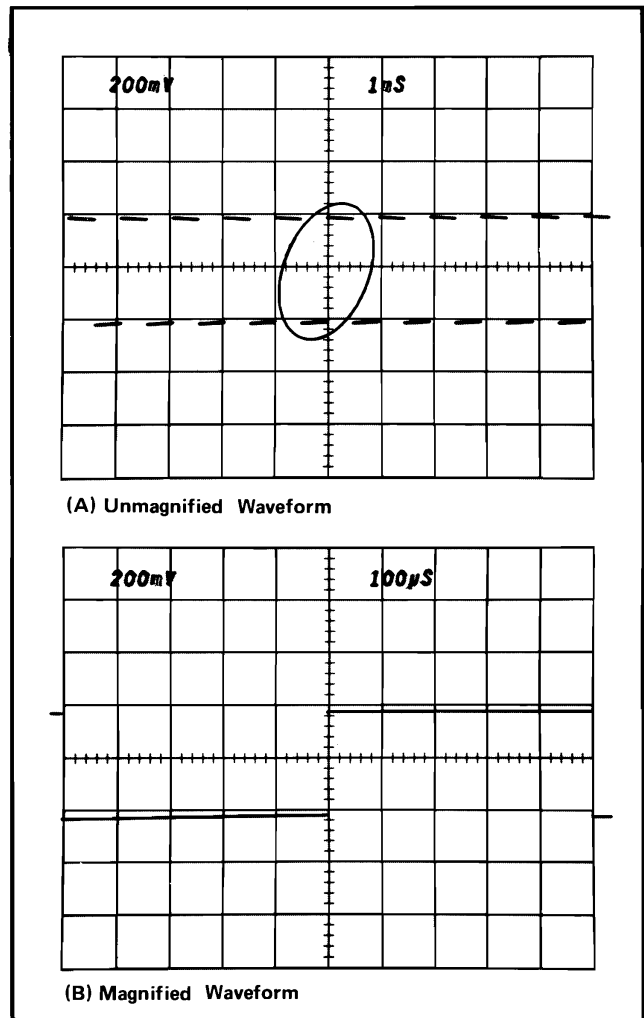

Fig. 2-9. Operation of sweep magnifier.

10. For example, if the TIME/DIV switch is set to .05 μ s, the equivalent magnified sweep rate is 5 nanoseconds/division. The equivalent magnified sweep rate must be used for all time measurements when the X10-MAGNIFIER button is lighted. The equivalent magnified sweep rate is calibrated when the VARIABLE TIME/DIV control is in the calibrated position.

Horizontal Position Control

The 7B70 provides both fine and coarse adjustment of positioning. The coarse adjustment provides rapid horizontal positioning of the trace. Fine positioning is provided for more precise control of trace position.

Display Mode

Time-Base. With the DISPLAY MODE switch in the TIME BASE position the 7B70 functions as a normal time-base with the sweep rate set by the TIME/DIV switch.

Amplifier. In some applications, it is desirable to display one signal versus another (X-Y) rather than against time. The AMPLIFIER position of the DISPLAY MODE switch provides a means for applying an external signal to the horizontal amplifier for this type of display. The correct COUPLING and SOURCE must be selected to correspond to the signal applied to the EXT VOLTS IN connector.

Two modes of external horizontal operation are provided. When the SOURCE switch is set to INT, the horizontal deflection is provided by a signal applied to the vertical amplifier. In the EXT and $EXT \div 10$ positions of the SOURCE switch, external horizontal deflection is provided by the signal applied to the EXT VOLTS IN connector. The signal coupling provided by the COUPLING switch can be used to select or reject components of the external horizontal signal.

The external horizontal deflection factor (with Amplifier VARIABLE fully clockwise) is approximately 25 millivolts per division in the EXT position of the SOURCE switch and approximately 250 millivolts per division in the $EXT \div 10$ position of the SOURCE switch.

APPLICATIONS

General

The following information describes the procedures and techniques for making basic measurements with a Tektronix 7700-series Oscilloscope. These applications are not described in detail, since each application must be adapted to the requirements of the individual measurement. This instrument can also be used for many applications not described in this manual. Contact your local Tektronix Field Office or representative for assistance in making specific measurements. Also, the following books describe oscilloscope measurement techniques which can be adapted for use with this instrument:

Harley Carter, "An Introduction to the Cathode Ray Oscilloscope", Philips Technical Library, Cleaver-Hume Press Ltd., London, 1960.

J. Czech, "Oscilloscope Measuring Technique", Philips Technical Library, Springer-Verlag, New York, 1965.

Robert G. Middleton and L. Donald Payne, "Using the Oscilloscope in Industrial Electronics", Howard W. Sams & Co. Inc., The Bobbs-Merrill Company Inc., Indianapolis, 1961.

John F. Rider and Seymour D. Uslan, "Encyclopedia of Cathode-Ray Oscilloscopes and Their Uses", John F. Rider Publisher Inc., New York, 1959.

John F. Rider, "Obtaining and Interpreting Test Scope Traces", John F. Rider Publisher Inc., New York, 1959.

Rufus P. Turner, "Practical Oscilloscope Handbook", Volumes 1 and 2, John F. Rider Publisher Inc., New York, 1964.

Frequency Comparison

Sweep Rates. To establish an arbitrary horizontal sweep rate based upon a specific reference frequency, proceed as follows:

1. Connect the reference signal to the vertical INPUT connector. Set the VOLTS/DIV switch for four or five divisions of vertical deflection.

2. Set the TIME/DIV switch and the VARIABLE TIME/DIV control so one cycle of the signal covers an exact number of horizontal divisions. Do not change the VARIABLE TIME/DIV control after obtaining the desired deflection. This display can be used as a reference for frequency comparison measurements.

3. To establish an arbitrary sweep rate so the repetition rate of an unknown signal can be measured accurately at any setting of the TIME/DIV switch, the repetition rate of the reference signal must be known. If it is not known, it can be measured before the VARIABLE TIME/DIV switch is set in step 2.

4. Divide the repetition rate of the reference signal (seconds) by the product of the horizontal deflection established in step 2 (divisions) and the setting of the TIME/DIV switch. This is the horizontal conversion factor:

Horizontal	reference signal repetition rate (seconds)		
Conversion =	horizontal		TIME/DIV
Factor	deflection	X	switch
	(divisions)		setting

5. To measure the repetition rate of an unknown signal, disconnect the reference signal and connect the unknown signal to the INPUT connector. Set the TIME/DIV switch to a setting that provides sufficient horizontal deflection to make an accurate measurement. Do not readjust the VARIABLE TIME/DIV control.

Operating Instructions—7B70 (SN B205000 and Up)

6. Measure the horizontal deflection in divisions and calculate the repetition rate of the unknown signal using the following formula:

$$\text{Repetition Rate} = \frac{\text{TIME/DIV switch setting}}{\text{horizontal conversion factor}} \times \text{horizontal deflection (divisions)}$$

NOTE

If the horizontal magnifier is used, be sure to use the magnified sweep rate in place of the TIME/DIV switch setting.

Example. Assume a reference signal frequency of 455 hertz (repetition rate 2.19 milliseconds), a TIME/DIV switch setting of .2 ms, and the VARIABLE TIME/DIV control adjusted to provide a horizontal deflection of eight divisions. Substituting these values in the horizontal conversion factor formula (step 4):

$$\text{Horizontal Conversion Factor} = \frac{2.19 \text{ milliseconds}}{.2 \times 8} = 1.37$$

Then, with a TIME/DIV switch setting of 50 μs, the repetition rate of an unknown signal which completes one cycle in seven horizontal divisions can be determined by using the repetition rate formula (step 6):

$$\text{Repetition Rate} = 50 \mu\text{s} \times 1.37 \times 7 = 480 \mu\text{s}$$

This answer can be converted to frequency by taking the reciprocal of the repetition rate (see application on Determining Frequency Measurements).

Time-Duration Measurements

To measure time between two points on a waveform, use the following procedure:

1. Connect the signal to either Vertical plug-in.
2. Set the MODE switch to display the plug-in used.
3. Set the VOLTS/DIV switch to display about four divisions of the waveform.
4. Set the 7B70 triggering controls to obtain a stable display.
5. Set the TIME/DIV switch to the fastest sweep rate that displays less than eight divisions between the time

measurement points (see Fig. 2-8). (See the topic entitled Horizontal Sweep Rate in this section concerning non-linearity of first and last divisions of a display.)

6. Adjust the vertical POSITION control to move the points between which the time measurement is made to the center horizontal reference line.

7. Adjust the horizontal POSITION control to position the time-measurement points within the center eight divisions of the graticule.

8. Measure the horizontal distance between the time measurement points. Be sure the A VARIABLE control is set to CAL.

9. Multiply the distance measured in step 8 by the setting of the TIME/DIV switch. If sweep magnification is used, divide this answer by 10.

Example. Assume that the distance between the time measurement points is five divisions (see Fig. 2-10), and the TIME/DIV switch is set to .1 ms with the magnifier to X1. Using the formula:

$$\text{Time Duration} = \frac{\text{horizontal distance (divisions)} \times \text{TIME/DIV setting}}{\text{magnification}}$$

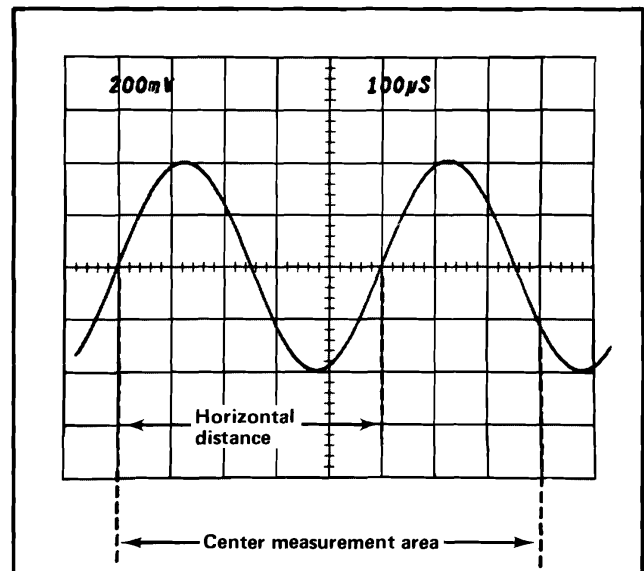

Fig. 2-10. Measuring the time duration between points on a waveform.

Substituting the given values:

$$\text{Time Duration} = \frac{5 \times 0.1 \text{ ms}}{1}$$

The time duration is 0.5 milliseconds.

Determining Frequency

The time measurement technique can also be used to determine the frequency of a signal. The frequency of a periodically recurrent signal is the reciprocal of the time duration (period) of one complete cycle.

Use the following procedure:

1. Measure the time duration of one complete cycle of the waveform as described in the previous application.
2. Take the reciprocal of the time duration to determine the frequency.

Example. The frequency of the signal shown in Fig. 2-10 which has a time duration of 0.5 milliseconds is:

$$\text{Frequency} = \frac{1}{\text{time duration}} = \frac{1}{0.5 \text{ ms}} = 2 \text{ kilohertz}$$

Risetime Measurements

Risetime measurements employ basically the same techniques as time-duration measurements. The main difference is the points between which the measurement is made. The following procedure gives the basic method of measuring risetime between the 10% and 90% points of the waveform. Falltime can be measured in the same manner on the trailing edge of the waveform.

1. Connect the signal to either Vertical plug-in.
2. Set the MODE switch to display the plug-in used.
3. Set the VOLTS/DIV switch and the VARIABLE control to produce a signal an exact number of divisions in amplitude.
4. Center the display about the center horizontal line with the vertical POSITION control.
5. Set the Triggering controls to obtain a stable display.

6. Set the TIME/DIV switch to the fastest sweep rate that displays less than eight divisions between the 10% and 90% points on the waveform.

7. Determine the 10% and 90% points on the rising portion of the waveform. The figures given in Table 2-1 are for the points 10% up from the start of the rising portion and 10% from the top of the rising portion (90% point).

TABLE 2-1

Risetime Measurements

Vertical display (divisions)	10% and 90% points	Divisions vertically between 10% and 90% points
4	0.4 and 3.6 divisions	3.2
5	0.5 and 4.5 divisions	4.0
6	0.6 and 5.4 divisions	4.8

8. Adjust the horizontal POSITION control to move the 10% point of the waveform to the center measurement area. For example, with a five-division display as shown in Fig. 2-11, the 10% point is 0.5 division up from the start of the rising portion.

9. Measure the horizontal distance between the 10% and 90% points. Be sure the A VARIABLE control is set to CAL.

10. Multiply the distance measured in step 9 by the setting of the TIME/DIV switch. If sweep magnification is used, divide this answer by 10.

Example. Assume that the horizontal distance between the 10% and 90% points is three divisions (see Fig. 2-11) and the TIME/DIV switch is set to 1 μs with the MAG switch set to X10. Applying the time duration formula to risetime:

$$\text{Time Duration (Risetime)} = \frac{\text{horizontal distance (divisions)} \times \text{TIME/DIV setting}}{\text{magnification}}$$

Substituting the given values:

$$\text{Risetime} = \frac{3 \times 1 \mu\text{s}}{10}$$

The risetime is 0.3 microsecond.

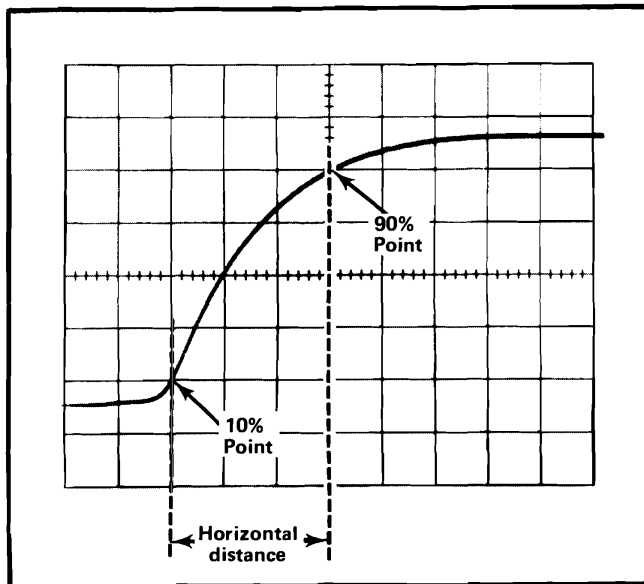

Fig. 2-11. Measuring risetime.

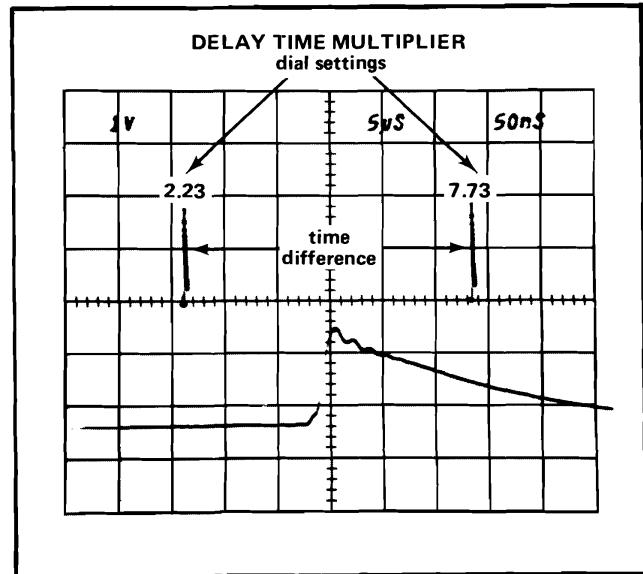

Fig. 2-12. Measuring time difference using delayed sweep.

Delayed Sweep Time Measurements

The delayed sweep mode can be used to make accurate time measurements. The following measurement determines the time difference between two pulses displayed on the same trace. This application may also be used to measure time difference from two different sources (dual-trace) or to measure time duration of a single pulse. See Section 1 for measurement accuracy.

1. Connect the signal to either vertical plug-in. Set the Indicator Oscilloscope vertical MODE selector to display the plug-in being used. Set the horizontal MODE selector to CHOP or ALT (see Oscilloscope Manual discussion on horizontal mode switching) to display both Time-Base sweeps.

2. Set the VOLTS/DIV selector to produce a display about three divisions in amplitude (see Fig. 2-12).

3. Set the A TIME/DIV to a sweep rate which displays about six divisions between pulses. Adjust the A Triggering controls for a stable display.

4. Set the A Time-Base B DELAY MODE selector to B STARTS AFTER DELAY.

5. Set the 7B70 (B) TIME/DIV to a setting 1/100 of the A TIME/DIV sweep rate. This produces an intensified portion about 0.1 division in length.

NOTE

Do not change the A LEVEL control setting or the horizontal POSITION control setting in the following steps, as the measurement accuracy will be affected.

6. Turn the DELAY-TIME MULTIPLIER dial to move the intensified portion of the A sweep to the first pulse.

7. Adjust the DELAY-TIME MULTIPLIER dial to move the pulse (or rising portion) of the B sweep to the center vertical line. Note the setting of the DELAY-TIME MULTIPLIER dial.

8. Turn the DELAY-TIME MULTIPLIER dial clockwise until the second pulse is positioned to this same point (if several pulses are displayed, observe the intensified portion of the A sweep to locate the correct pulse). Again note the dial setting.

9. Subtract the first dial setting from the second and multiply by the delay time shown by the A TIME/DIV selector. This is the time interval between the pulses.

Example: Assume the first dial setting is 2.23 and the second dial setting is 7.73 with the TIME/DIV set to 5 μ S (see Fig. 2-12).

Using the formula:

Time Difference =
(delayed sweep)

$$\text{second dial setting} - \text{first dial setting} \times \text{delay time (A TIME/DIV setting)}$$

Substituting the given values:

$$\text{Time Difference} = (7.73 - 2.23) \times 5 \mu\text{s}.$$

The time difference is 27.5 microseconds

Delayed Sweep Magnification

The delayed sweep feature can be used to provide higher apparent magnification than is provided by the MAG switch. The sweep rate of the DELAYED SWEEP (7B70) is not actually increased; the apparent magnification is the result of delaying the B sweep an amount of time selected by the A TIME/DIV switch and the DELAY-TIME MULTIPLIER dial before the display is presented at the sweep rate selected by the B TIME/DIV switch. The following method uses the B STARTS AFTER DELAY position to allow the delayed portion to be positioned with the DELAY-TIME MULTIPLIER dial. If there is too much jitter in the delayed display, use the Triggered Delayed Sweep Magnification procedure.

1. Connect the signal to either vertical plug-in. Set the Indicator Oscilloscope vertical MODE selector to display the plug-in used and the horizontal MODE to CHOP or ALT to display both Time-Base sweeps.

2. Set the VOLTS/DIV selector to produce a display about three divisions in amplitude.

3. Set the A Time-Base B DELAY MODE selector to B STARTS AFTER DELAY. Adjust the A Triggering controls for a stable display.

4. Set the A TIME/DIV to a sweep rate which displays the complete waveform.

5. Position the start of the intensified portion with the DELAY-TIME MULTIPLIER dial to the part of the display to be magnified.

6. Set the 7B70 TIME/DIV to a setting which intensifies the full portion to be magnified. The start of the intensified trace remains as positioned above.

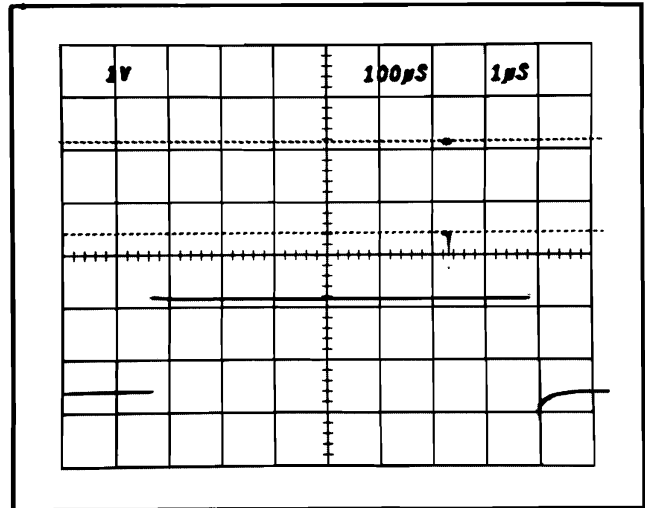

Fig. 2-13. Using delayed sweep for sweep magnification.

7. Time measurements can be made from the display in the conventional manner. Sweep rate is determined by the setting of the 7B70 TIME/DIV selector.

Example: The apparent magnification of the display shown in Fig. 2-13 with an A TIME/DIV setting of .1 ms and a B TIME/DIV setting of 1 µs is:

$$\text{Apparent Magnification (Delayed Sweep)} = \frac{\text{A TIME/DIV setting}}{\text{B TIME/DIV setting}}$$

Substituting the given values:

$$\text{Apparent Magnification} = \frac{1 \times 10^{-4}}{1 \times 10^{-6}} = 100$$

The apparent magnification is 100 times.

Triggered Delayed Sweep Magnification. The delayed sweep magnification method just described may produce too much jitter at high apparent magnification ranges. The B TRIGGERABLE AFTER DELAY position of the A Time-Base B DELAY MODE selector provides a more stable display, since the delayed display is triggered at the same point each time.

1. Set up the display as given in steps 1 through 6 above.

2. Set the B DELAY MODE selector to B TRIGGERABLE AFTER DELAY.

Operating Instructions—7B70 (SN B205000 and Up)

3. Adjust the B LEVEL SLOPE control so the intensified portion on the trace is stable.

4. Inability to intensify the desired portion indicates that the 7B70 Triggering controls are incorrectly set or the signal does not meet the triggering requirements. If the condition cannot be remedied with the B Triggering controls or by increasing the display amplitude (lower VOLTS/DIV setting), trigger the B sweep externally.

5. Measurement and magnification are as described above.

Displaying Complex Signals Using Delayed Sweep

Complex signals often consist of a number of individual events of differing amplitudes. Since the trigger circuits are sensitive to changes in signal amplitude, a stable display can normally be obtained only when the sweep is triggered by the event(s) having the greatest amplitude. However, this may not produce the desired display of a lower-amplitude portion which follows the triggering event. The delayed sweep feature provides a means of delaying the start of the B sweep by a selected amount following the event which triggers the A Sweep. Then, the part of the waveform which contains the information of interest can be displayed.

Use the following procedure:

1. Set up the display as given in Delayed Sweep Magnification Steps 1 through 6.

2. Time measurements can be made from the display in the conventional manner. Sweep rate is determined by the setting of the 7B70 TIME/DIV selector.

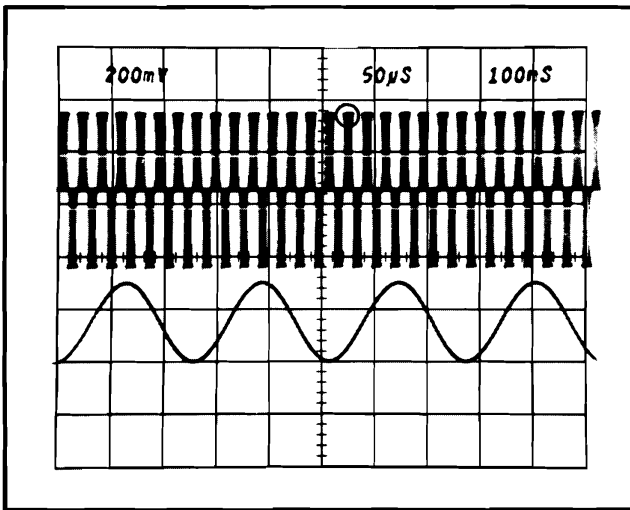

Fig. 2-14. Displaying a complex signal using delayed sweep.

Example. Fig. 2-14 shows a complex waveform as displayed on the CRT. The intensified portion of the waveform cannot be viewed in any greater detail because the sweep is triggered by the larger amplitude pulses at the start of the display and a faster sweep rate moves this area of the waveform off the viewing area. The second waveform shows the area of interest magnified 500 times using Delayed Sweep. The DELAY-TIME MULTIPLIER dial has been adjusted so the delayed sweep starts just before the area of interest.

Pulse Jitter Measurements

In some applications it is necessary to measure the amount of jitter on the leading edge of a pulse or jitter between pulses.

1. Set up the display as in the above procedure.

2. Set the B DELAY MODE selector to B STARTS AFTER DELAY. Slight readjustment of the B Triggering LEVEL control may be necessary to produce as stable a display as possible.

3. Pulse jitter is shown by horizontal movement on the pulse (take into account inherent jitter of Delayed Sweep). Measure the amount of horizontal movement. Be sure both VARIABLE TIME/DIV controls are set to CAL.

4. Multiply the distance measured in step 3 by the B TIME/DIV switch setting to obtain pulse jitter in time.

Example. Assume that the horizontal movement is 0.5 division (see Fig. 2-15), and the B TIME/DIV switch setting is $.5 \mu\text{s}$.

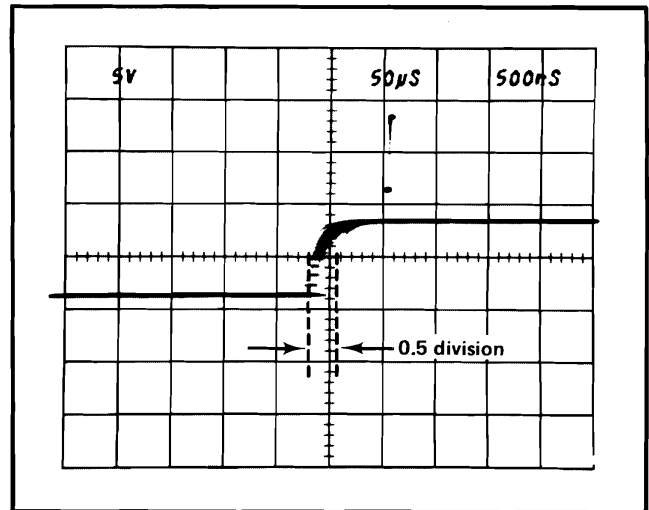

Fig. 2-15. Measuring pulse jitter.

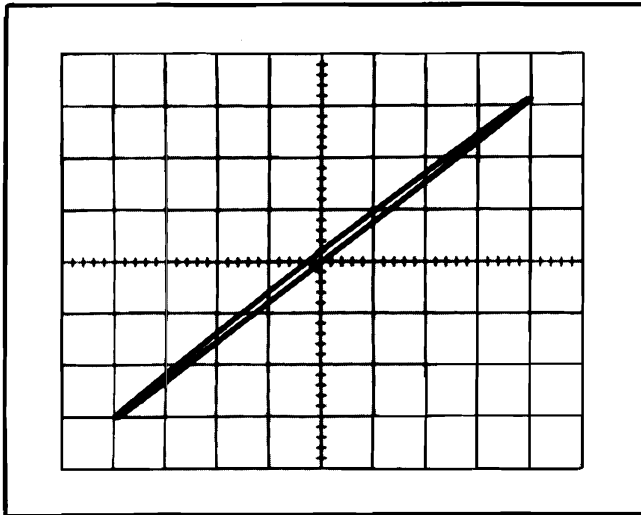

Fig. 2-16. X-Y display showing phase shift.

Using the formula:

$$\text{Pulse Jitter} = \frac{\text{horizontal jitter (divisions)}}{\text{B TIME/DIV setting}} \times \text{X}$$

Substituting the given values:

$$\text{Pulse Jitter} = 0.5 \times 0.5 \mu\text{s}$$

The pulse jitter is 0.25 microseconds.

X-Y Phase Measurements

The X-Y phase measurement method can be used to measure the phase difference between two signals of the same frequency. In this mode, one of the sine-wave signals provides horizontal deflection (X) while the other signal provides the vertical deflection (Y). The phase angle between the two signals can be determined from the lissajous pattern as follows:

1. Place one 7B70 in the horizontal compartment and another 7B70 (or a vertical unit) in the vertical compartment of the oscilloscope.

2. Set both 7B70 controls as follows:

DISPLAY MODE	AMPLIFIER
COUPLING	AC
SOURCE	EXT

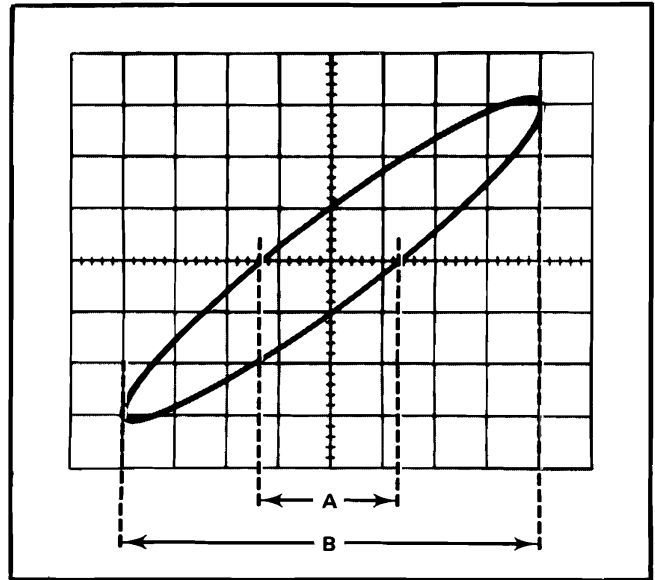

Fig. 2-17. Phase-difference measurement from an X-Y display.

3. Connect the same signal to both EXT VOLTS IN connectors. Use the Amplifier VARIABLE controls to obtain a display less than 8 divisions vertically and less than 10 divisions horizontally. Measure and record the inherent phase shift for the oscilloscope system being used. See Fig. 2-16.

4. Connect the Y signal to the 7B70 in the vertical compartment and the X signal to the 7B70 in the horizontal compartment.

5. Center the display in relation to the vertical graticule line. Measure the distances A and B as shown in Fig. 2-17. Distance A is the horizontal measurement between the two points where the trace crosses the center horizontal reference line. Distance B is the horizontal width of the display.

6. Divide A by B to obtain the sine of the phase angle between the two signals. Obtain the phase angle from a trigonometric table and subtract the inherent phase shift to obtain the actual phase difference.

Example. The phase angle shown in Fig. 2-16 is approximately 2° and in Fig. 2-17 the phase angle is 18° .

Measured Phase	—	Inherent Phase	=	Actual Phase
Angle		Shift		Angle
18°		2°		16°

SECTION 3

CIRCUIT DESCRIPTION

Change information, if any, affecting this section will be found at the rear of the manual.

Introduction

This section of the manual contains a description of the circuitry used in the 7B70. Detailed block diagrams are used to show the interconnections between the stages in each major circuit and the relationship of the front-panel controls to the individual stages.

A complete block diagram is located in the Diagrams Section at the rear of this manual. This diagram shows the overall relationship between all of the circuits. Complete schematics of each circuit are also given in the Diagrams Section. Refer to these diagrams throughout the following circuit description for electrical values and relationship.

BLOCK DIAGRAM

General

The following discussion of the block diagram at the back of this manual is provided to aid in understanding the overall concept of the 7B70 before the individual circuits are discussed in detail. Each block represents a major circuit within this instrument.

The selection of INTERNAL or EXTERNAL triggering is made in the Trigger Input circuit. This stage also sets the gain and DC balance of the external trigger input. To increase the range of the external trigger input, a 10X attenuator network is incorporated in the input of the external trigger amplifier.

The Trigger Amplifier circuit provides amplification and waveshaping of the selected input trigger signal. Level centering, slope selection and coupling controls are contained in this circuit.

The Peak Detector provides the logic necessary for P-P AUTO mode operation. The peak sensing circuits set the range of the LEVEL control to allow triggering over most of the range of the input signal. This circuit contains level, mode, coupling and source controls.

The Trigger Generator circuits produce an output pulse which initiates the sweep signal produced by sweep generator circuits. The sweep gate multivibrator produces a Sweep

Gate for use by the indicator oscilloscope. The bright-line auto feature which provides a free-running trace in the absence of triggering signals is contained in this stage. The TRIG'D light is also connected to the bright-line auto circuit to indicate the presence of a trigger signal.

The Sweep Generator circuit produces a linear sawtooth output signal when initiated by the trigger generator. The slope of the sawtooth produced by the sweep generator is controlled by the TIME/DIV switch setting. The operating mode of the sweep generator is controlled by the TRIGGERING MODE switch. In the P-P AUTO and AUTO positions, the absence of a trigger signal causes the sweep to free run. In the NORM position, a horizontal sweep is initiated only when triggered by an adequate trigger signal. The SINGLE SWEEP position allows only one sweep to be initiated after the circuit is reset with the RESET button or by the remote reset control.

The Horizontal Preamp is a single-ended to push-pull amplifier. The output of the sweep generator circuit is amplified by this circuit to produce horizontal deflection for the oscilloscope. This circuit contains a 10 times magnifier to increase the sweep rate ten times in any TIME/DIV switch setting. Horizontal positioning is incorporated in this stage.

DETAILED CIRCUIT DESCRIPTION

General

The following circuit analysis is written around the detailed block diagrams which are given for each major circuit. These detailed block diagrams give the names of the individual stages within the major circuits and show how they are connected together. The block diagrams also show the inputs and outputs for each major circuit and the relationship of the front panel controls to the individual stages. The names assigned to the individual stages on the detailed block diagrams are used throughout the following discussion.

TRIGGER INPUT

Input Source

The internal trigger signal from the vertical deflection system is coupled directly through this stage to the trigger amplifier. The external trigger signal can be AC or DC

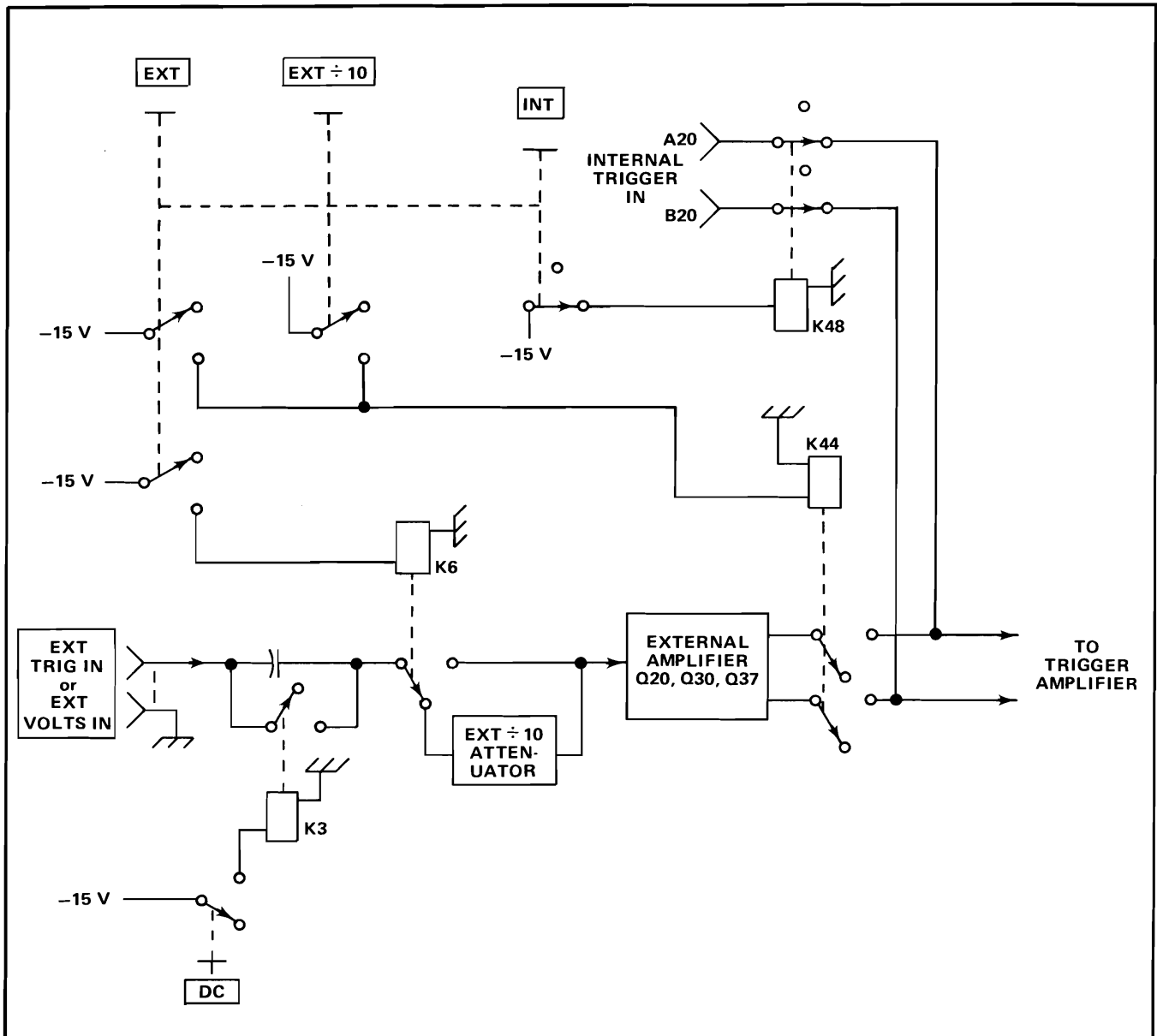

Fig. 3-1. Simplified block diagram of the trigger input.

coupled to the external input amplifier. See Fig. 3-1 for a simplified block diagram of the Trigger Input Stage.

TRIGGER AMPLIFIER

External Input Amplifier

The external signal is converted from single-ended to push-pull by paraphase amplifier, Q20A and Q20B. The gain of this amplifier is set by R25 for a push-pull gain of 0.2. R37 is used to DC balance the output and is adjusted for a voltage null between the push-pull output lines. A divide-by-10 attenuator network in the input to this amplifier can be selected by the front panel EXT ÷10 push-button to extend the triggering level range of the unit.

General

The Trigger Amplifier circuit provides slope and level selection of the trigger signal applied to the Trigger Generator. The P-P AUTO feature is also incorporated in this circuit. Other controls provided in this circuit are AC LF REJ, DC, AC HF REJ and LINE TRIGGERING SOURCE. Fig. 3-2 shows a detailed block diagram of the Trigger Amplifier circuit. A schematic of this circuit is shown on diagrams 2 and 3 at the back of this manual.

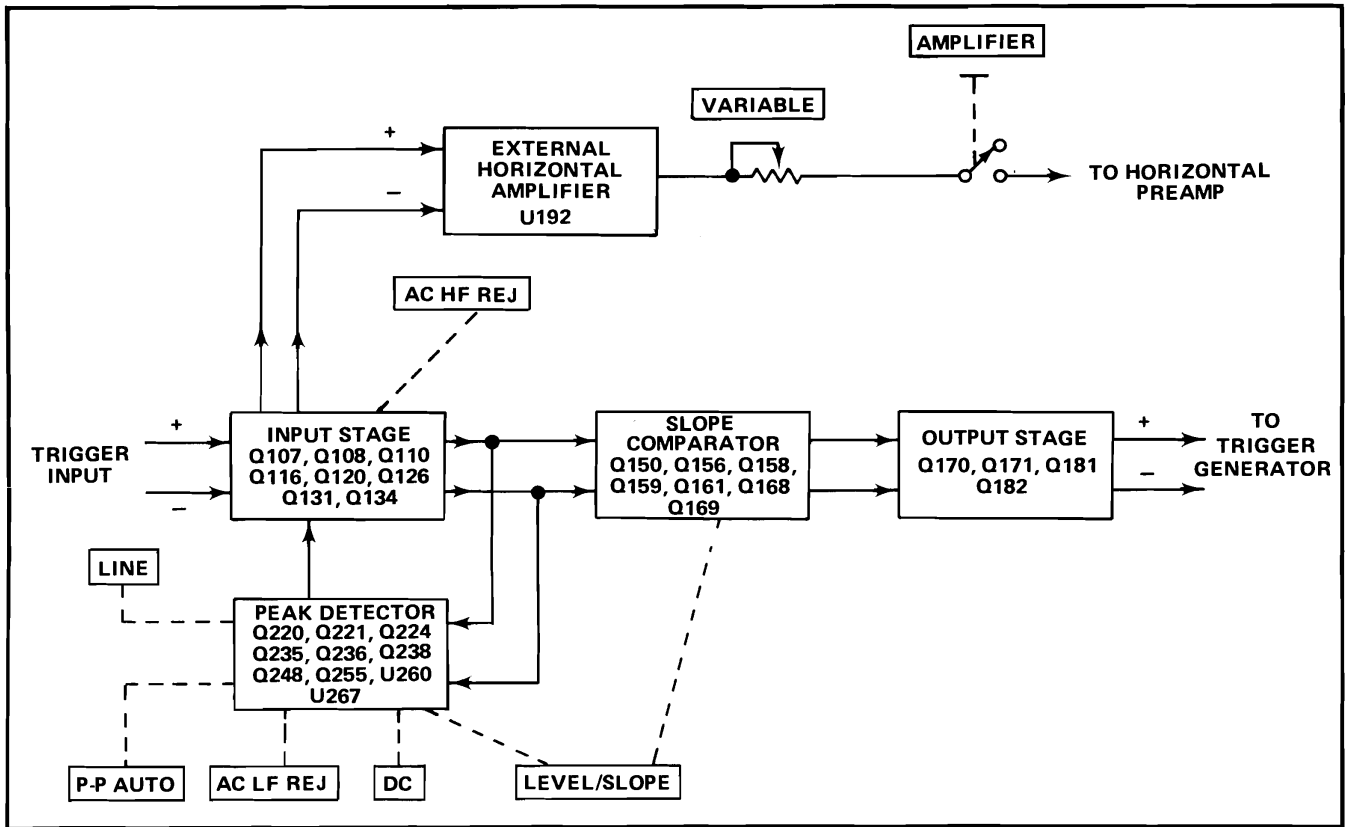

Fig. 3-2. Simplified block diagram of trigger amplifier.

Input Stage

The trigger signal (internal or external as selected by the SOURCE switch) is applied push-pull to the bases of Q107 and Q108. Impedance compensating networks R100, C100, L100 and R101 at the base of Q107 and R104, C104, L104 and R103 at the base of Q108 provide a 50 ohm input for the trigger signal. Q126 with a voltage divider network R126, R127, R128 provides a DC reference level for Q116. Q120, R119, R120, R121, R122 and the output of the peak detector circuit provides a variable voltage source for Q110. R121 is adjustable to DC balance this stage with the LEVEL control set to 9:00 o'clock (centered on the positive slope). Q110-R111 and Q116-R117 provide the current source for Q107 and Q108 respectively.

The AC HF REJ control, located in the output of the cascode Input Stage, engages C138 to provide attenuation of signals above 50 kHz.

Peak Detector

The triggering level, with the MODE switch set to P-P AUTO, is controlled by the Peak Detector stage. The signal from the trigger amplifier input stage is applied to the Peak Detector peak sensing network. The output of the Peak

Detector sets the voltage applied to the LEVEL control (R146A) so that the range of the LEVEL control corresponds to the peak-to-peak amplitude or less of the input signal.

The positive portion of the input signal is inverted by the trigger input stage and applied through CR210 to the peak sensing network, C210 charges to the peak value of the input signal. The signal is amplified by Q220-Q224 and applied to the gate of source follower Q248. Current through Q248 decreases and the voltage at the wiper of R251 becomes more negative. This negative-going signal is inverted by operational amplifier U260, and applied to the top of the LEVEL control, R146A.

At the end of the positive input signal the voltage at the source of Q248 rises at a rate determined by C248 and R241. The feedback from the source of Q248 aids in holding the charge on C210. For signals with a repetition rate of about 200 hertz or greater, the peak sensing network will remain charged to the peak level of the input signal.

The negative portion of the input signal is applied in-phase to the Peak Detector. The operation of the peak

Circuit Description—7B70 (SN B205000 and Up)

sensing network is the same as that described for the peak positive sensing network. The output at the source of Q255 is applied to the bottom of LEVEL control R146A as a negative-going voltage which represents the peak negative value of the signal input.

MODE, COUPLING and SOURCE controls are included in the output stage of the Peak Detector.

Slope Comparator

The Slope Comparator is the electronic equivalent of a double-pole double-throw switch. With the SLOPE switch set for positive slope triggering, Q158-Q159 are on and Q161-Q168-Q169 are off. For negative slope triggering, Q161-Q168-Q169 are on and Q158-Q159 are off. R155 adjusts the negative P-P AUTO triggering when the LEVEL/SLOPE control is set to the negative slope.

Output Stage

The output of the slope comparator is applied through the Output Stage to the trigger generator circuit. Diodes CR181 and CR182 limit the push-pull output of the trigger amplifier to about one volt peak-to-peak.

TRIGGER GENERATOR

Trigger Pulse Generator

The Trigger Pulse Generator (see Fig. 3-3) shapes the output of the Trigger Amplifier to provide a trigger pulse with a fast leading edge. Tunnel diode VR304 is quiescently in its low-voltage state. The signal from the Trigger Amplifier switches it to its high-voltage state causing a negative-going fast rise pulse at the base of Q317 and a positive-going pulse at the base of Q309. The output of the Trigger Pulse Generator, at the collector of Q317, is a positive-going fast rise pulse which is applied to the Sweep Gate Stage. The output at the collector of Q309 is a negative-going pulse which is applied to the bright-line Auto circuit. VR304 reverts back to its low-voltage state when the signal from the Trigger Amplifier decreases sufficiently. VR304 runs at the repetition rate of the input signal.

Sweep Gate Stage

The Sweep Gate Stage produces a negative-going step to start the Sweep Generator and a positive gate for use in the oscilloscope.

The positive-going pulse from the Trigger Pulse Generator enables CR319, opening an additional current path for

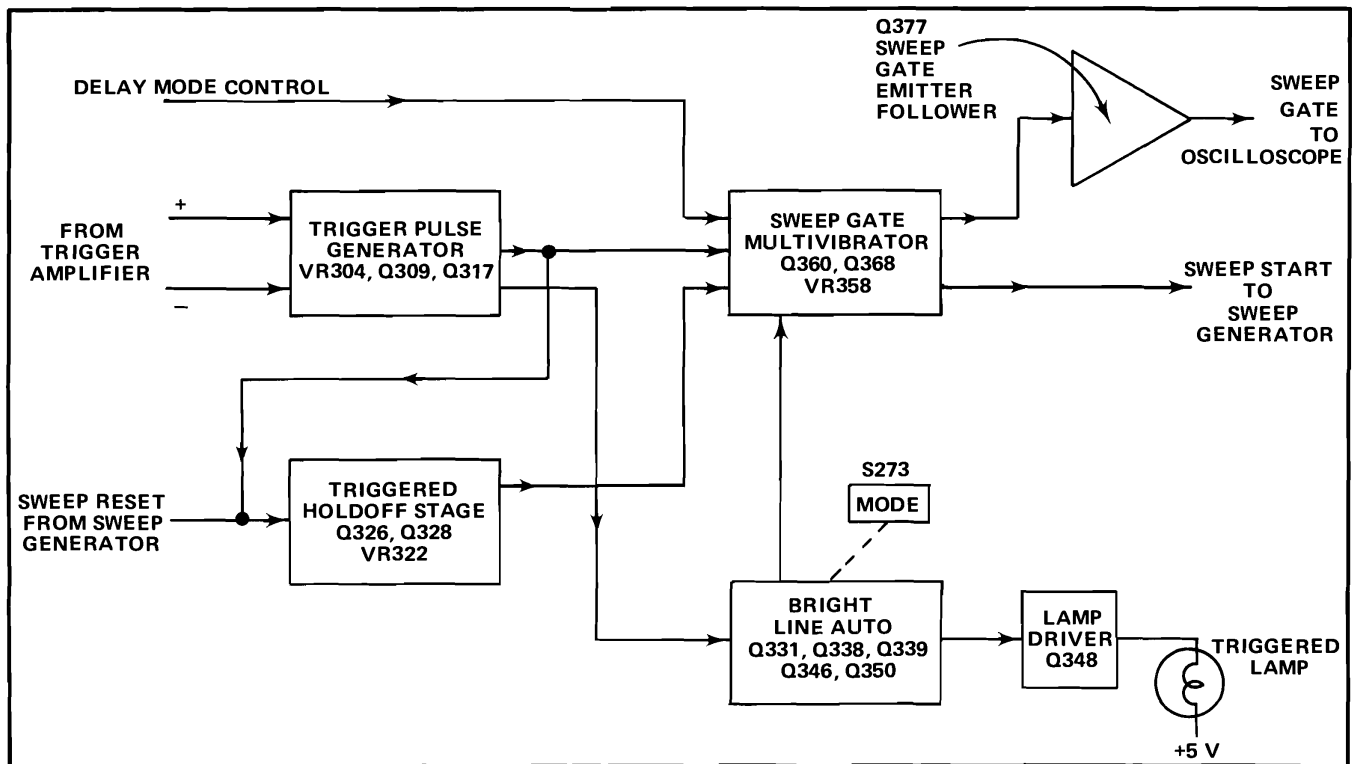

Fig. 3-3. Simplified block diagram of Trigger Generator circuit.

VR358, the sweep gate tunnel diode. VR358 switches to its high-voltage state applying a positive signal to the base of Q360 (part of the bistable sweep gate multivibrator). The collector voltage of Q360 decreases, producing the negative-going step used to enable the Sweep Generator. When Q360 turns on, emitter-coupled Q368 is turned off to produce the positive edge of the sweep gate output. The sweep gate multivibrator remains in this stage, Q360 on and Q368 off, until it is reset by the sweep reset multivibrator (part of the Sweep Generator) at the end of the sweep.

At the end of the sweep, the negative-going lockout gate from the sweep reset multivibrator is applied to the base of Q326, turning it off. Emitter-coupled Q328 is turned on taking current from the sweep gate tunnel diode, VR358, reverting it to its low-voltage state. This switches the sweep gate multivibrator back to its quiescent state (Q360 off and Q368 on). The circuit remains in this condition (VR358 in its low-voltage state) until the lockout gate returns to its high-level at the end of holdoff time.

Triggered Holdoff Stage

The Triggered Holdoff Stage re-arms the sweep gate TD, VR358, at the end of holdoff time. During holdoff time VR322 is in its high-voltage state, biasing Q326 off. At the end of holdoff time the lockout gate from the sweep reset multivibrator returns to its high level. This switches VR322 to its low-voltage state, turning Q326 on. Q328, which is emitter-coupled to Q326, is turned off to re-arm the sweep gate TD, VR358.

At high frequencies, double triggering may occur due to the finite risetime of the lockout gate as it returns to its high-level. To reduce the incidence of double triggering of the circuit, the trigger pulse from Q317 is differentiated by C324-R324 and super-imposed on the lockout gate at the cathode of VR322. Now the sweep is re-armed by one trigger pulse and triggered by the following trigger pulse, maintaining the proper time relationship between input signal and the start of the sweep.

Bright Line Auto

The operation of the sweep gate stage in the P-P AUTO and AUTO MODE is the same as for NORM MODE just described when an adequate trigger signal is present. However, when a trigger signal is not present, a free-running trace is produced in the P-P AUTO and AUTO MODES.

With no trigger signal applied to the circuit, Q331, Q338 and Q339 are off. This allows C339 to charge toward the positive 15 volt supply. As the top of C339 becomes more positive, CR342 is turned on making the base of Q346 move positive to cutoff. Emitter-coupled Q350 is turned on and the additional current through VR358 switches the TD

to its high-voltage state, automatically retriggering the sweep each time the lockout gate goes to its high level. The result is that the sweep generator circuit is automatically retriggered at the end of each holdoff period and a free-running trace is produced. Since the trace free-runs at the sweep rate of the sweep generator circuit (as selected by the TIME/DIV switch), a bright reference trace is produced at all sweep rates. The sweep TRIGGERED lamp will not be lit, indicating an untriggered condition.

The sweep TRIGGERED lamp is lit each time an adequate trigger signal is applied to the Pulse Generator. When the trigger signal switches VR304 to its high-voltage state, Q309 is turned off. This turns on Q331, Q338 and Q339. The top of C339 becomes less positive, turning off CR342. Q346 is turned on and its collector goes positive, turning on Q348. Q348 collector current lights the sweep TRIGGERED lamp. When Q346 turns on its emitter voltage decreases, and emitter-coupled Q350 is turned off to disconnect the bright line auto circuit from the sweep gate stage.

When the TRIGGERING MODE switch is in the NORM or SINGLE SWEEP position, the anode of CR355 is clamped to ground. This reverse-biases CR355 and disconnects the bright line auto circuit from the sweep gate stage but allows the TRIG'D light to function.

EXTERNAL HORIZONTAL AMPLIFIER

When the DISPLAY MODE switch is set to AMPLIFIER, the +15 volts is disconnected from the base of Q370 turning off the sweep gate multivibrator current source. This disables the Sweep Generator circuit. The Trigger Amplifier is disabled by removing the +15 volts from the junction of R148-R149. The indicator oscilloscope knob readout for the 7B70 is also disabled by applying +15 volts through R197 to the column current output, interface connector A37.

The signal, external or internal as selected by the SOURCE switch, is applied push-pull to operational amplifier U192. A DC level adjustment (R186), located in the input to U192, provides a means of adjusting the amplifier for minimum horizontal movement of the spot as the VARIABLE control is rotated. U192 converts the push-pull input to a single-ended output for use in the Horizontal Preamp.

The output of the External Horizontal Amplifier is passed through the VARIABLE control (R194). This control varies the output of the amplifier by a factor of up to 10. With the VARIABLE control fully clockwise the deflection factor is about 25 millivolts per division, and with the VARIABLE control fully counterclockwise the deflection factor is about 250 millivolts per division.

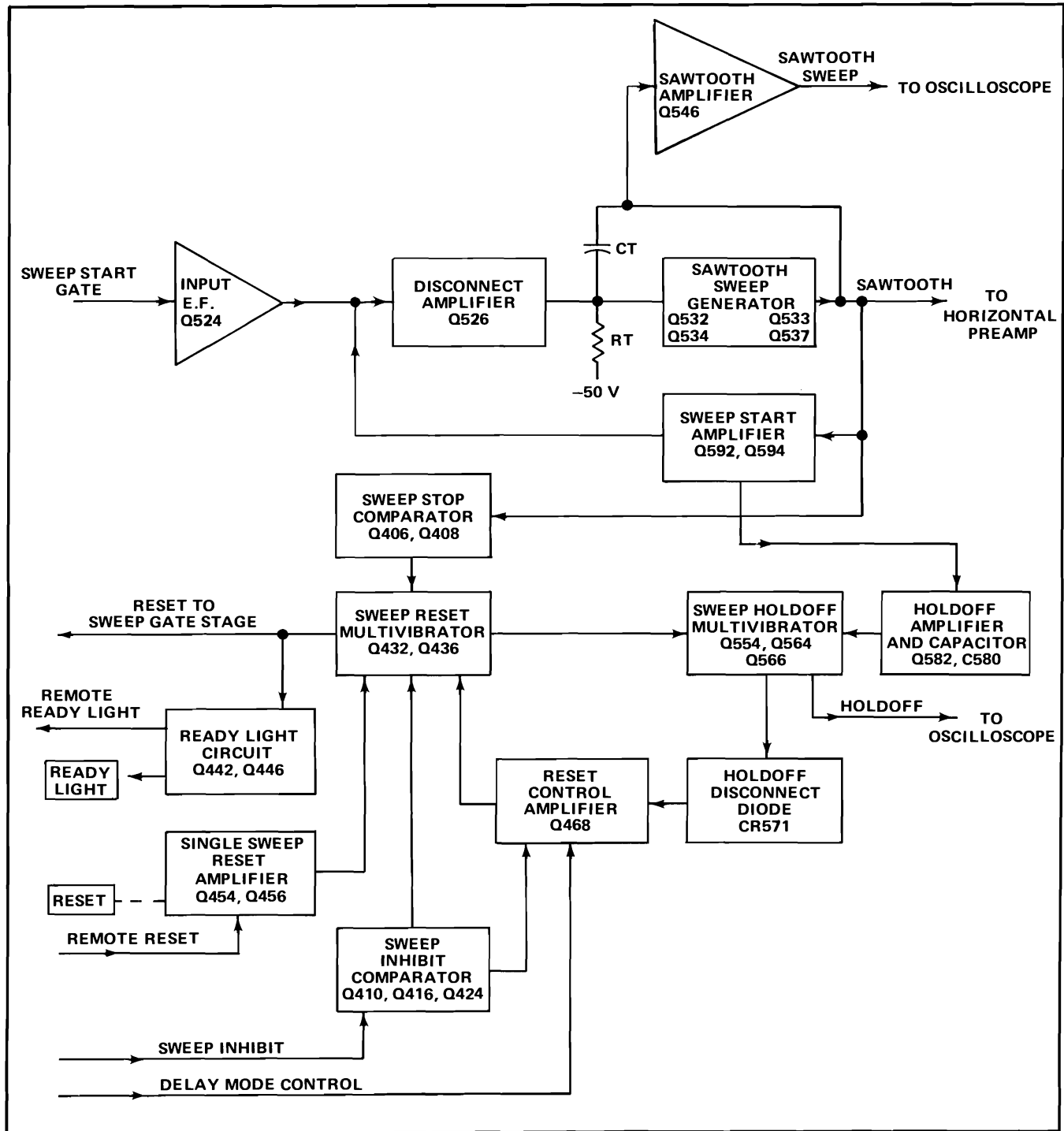

Fig. 3-4. Sweep Generator block diagram.

TIME-BASE GENERATOR

General

The Time-Base Generator circuit (see Fig. 3-4) produces a sawtooth voltage which is changed from single-ended to

push-pull by the Horizontal Preamp and used by the Indicator Oscilloscope to provide horizontal sweep deflection on the CRT. In addition this circuit produces various control signals for use by the Indicator Oscilloscope as well as internal signals for use in the Plug-in.

Normal Trigger Mode Operation

Disconnect Amplifier. The Disconnect Amplifier, Q526, is quiescently conducting current through R523 and the Timing Resistor, R530. The negative-going step from the Sweep Gate Multivibrator is applied to the base of the input emitter-follower, Q524. Q524 couples the negative step to the emitter of Disconnect Amplifier Q526, turning it off. The timing current through Timing Resistor R530 now starts to charge Timing Capacitor C530, enabling the Time-Base Generator.

The Disconnect Amplifier is a low-leakage transistor to improve timing at low sweep speeds and high temperatures. At the end of the sweep, Q526 turns on, discharging the Timing Capacitor. CR525 provides isolation between the Disconnect Amplifier and the input emitter-follower during holdoff time.

Sawtooth Sweep Generator. The basic sweep generator circuit is a Miller Integrator Circuit.¹ The current flow through the Disconnect Amplifier is interrupted by the signal from the Sweep Gate Stage. The Timing Capacitor, C530, now begins to charge through Timing Resistor R530. The Timing Resistor and Timing Capacitor are selected by the TIME/DIV switch (a front panel control) to provide sweep rates as listed on the front panel.

As the Timing Capacitor begins to charge toward the voltage applied to the Timing Resistor, the gate of Q532A, which is tied to the junction of R530-C530, goes negative by the same amount. This decreases the current through Q532A, forcing more current through Q532B. This increase in Q532B drain current flowing through R534 gives a negative-going voltage at the base of Q533. This causes the collector voltage of Q533 to pull up. The positive side of the Timing Capacitor, being tied to the collector of Q534, is also pulled up. This action results in a positive-going voltage being applied across the Timing Capacitor, maintaining a constant charging current and giving a linear rate of rise to the sawtooth output signal. The sawtooth output signal continues to rise in this manner until the Sweep Gate Multivibrator is switched to turn on the Disconnect Amplifier.

The sawtooth output from the collector of Q534 is connected to the Horizontal Preamp, and through R539 to the Sweep Start Amplifier, Sweep Stop Comparator, and through amplifier Q546 to the Indicator Oscilloscope. CR528-CR529 protects against gate-source breakdown of Q532A.

¹MILLMAN & TAUB pp 540-548.

Sweep Start Amplifier. Q592A sets the quiescent voltage of the sawtooth. The collector current of Q592A; flowing through R523, establishes the correct starting point of the sawtooth output signal. L593-R596 prevent oscillations at the faster sweep rates. They are paralleled with R592 at the slower sweep rates. CR594 and CR592 prevent base-emitter breakdown of Q592A and Q592B.

The sawtooth signal is applied through R539 to the base of Q592B. This positive-going signal causes Q594 to turn on, pulling down the collector voltage of Q592B and Q594.

The negative-going voltage at the collector of Q592 is applied through current-limiting diode CR581, to the base of Q582 to charge the holdoff capacitor.

Sweep Stop Comparator. The Sweep Stop Comparator is used to terminate the sawtooth sweep when the sweep has reached a pre-determined level. The circuit components are chosen to set the reference level for sweep termination at approximately 10.5 volts at the base of Q408. The positive-going sawtooth applied to the base of Q408 increases the current through R408-R409. The base of Q406, which is tied to the junction of R408-R409, rises an amount corresponding to the sawtooth amplitude at the base of Q408. This action continues until the emitter of Q406 becomes positive enough to forward bias CR406. When CR406 turns on, the positive rise at the base of Q436 switches the reset multivibrator. The voltage at the collector of Q436 goes negative and this negative-going step applied to the sweep gate circuit ends the sweep.

Holdoff Capacitor and Amplifier. Q582, which is turned on during sweep time, charges the holdoff capacitor. When the sweep ends, Q582 turns off. Now the holdoff capacitor starts to discharge toward -50 volts through R582 and at some sweep rates, through R580. When the top of C580 discharges negative enough to forward-bias CR574 and CR575, the holdoff capacitor voltage is applied to the base of Q554. This drives Q554 to cutoff, switching the holdoff multivibrator to end holdoff time. Voltage limiting diodes CR580 and CR582 protect the base-emitter junction of Q582. CR581 limits the "on" base current of Q582. VR576 and CR576 limit the negative voltage on holdoff capacitor C580.

The HF STAB control, R146B, through R583, varies the discharge rate of the holdoff capacitor to provide a stable display at fast sweep rates. This change in holdoff allows sweep synchronization for less display jitter at the faster sweep rates. The HF STAB circuit has little effect at slow sweep rates.

Circuit Description—7B70 (SN B20500 and Up)

Sweep Holdoff Multivibrator. Q554-Q564 are connected in a bi-stable Schmitt Trigger configuration. Quiescently Q554 is off and Q564 is on. A positive pulse from the sweep reset multivibrator switches the holdoff multivibrator to its second stable state, Q554 on and Q564 off.

The sweep holdoff multivibrator is returned to its first stable state when the holdoff capacitor has charged negative enough to drive Q554 to cutoff. The fast switching action of the sweep holdoff multivibrator produces sharp leading and trailing edges for the sweep holdoff gate. The output of the multivibrator, coupled through emitter-follower Q566, goes to the indicator oscilloscope and to the holdoff disconnect diode.

During sweep time the voltage on the holdoff capacitor reverse-biases CR575 and the current in R573 switches to CR572, turning off Q468. VR573 determines the time when the current switch takes place. During holdoff time the holdoff disconnect diode, CR571, controls the current available to the reset control amplifier, Q468. The positive-going edge of the holdoff gate turns on CR571. This moves the emitter of Q468 positive, turning it off. At the end of holdoff time the negative-going edge of the holdoff gate opens CR571, making the current through R468 available to the reset control amplifier.

Reset Control Amplifier. Q468 provides current to the base of Q436 to switch the sweep reset multivibrator to its reset state. The current through R468 into the emitter of Q468 is controlled by CR571 and CR572 as stated above, or by CR468 as explained under single-sweep operation.

Sweep Reset Multivibrator. The sweep reset multivibrator, Q432-Q436, resets the sweep gate TD at the end of holdoff time. In the reset state, Q432 is off and Q436 is conducting. The top of R438 is pulled up to its high level. The sweep is terminated by current from Q406 moving the base of Q436 positive to cutoff. This switches the multivibrator to its other stable state, Q432 on and Q436 off. The voltage at the top of R438 drops negative to its low level. This negative step is applied to the sweep gate stage to latch the sweep gate TD in its low-voltage state.

At the end of holdoff time, Q468 is turned on, driving the base of Q436 less positive. This turns Q436 on and the multivibrator switches back to its reset state. The voltage at the top of R438 is pulled up to its high level. This positive-going step is applied to the Sweep Gate Stage to unlatch the Sweep Gate TD, and the sweep circuits are ready for the next sweep to start.

Single Sweep Operation

General. Operation of the Sweep Generator Circuit in the SINGLE SWEEP position of the TRIGGERING MODE

switch is similar to operation in the other modes. However, after one sweep has been produced, the Sweep Reset Multivibrator Stage does not reset. All succeeding trigger pulses are locked out until the RESET button is pressed.

In the SINGLE SWEEP position of the MODE switch, the -15 volts is removed from the top of R464. CR466 is opened and CR468 becomes forward-biased, opening a current path through R468-CR468-R466. Now, at the end of holdoff, there is no current through Q468 to pull down the base of Q436 and the Sweep Reset Multivibrator does not reset. The circuit remains in this condition until reset by the Single Sweep Reset Amplifier Stage.

Single Sweep Reset Amplifier. The Single Sweep Reset Amplifier produces a negative pulse to reset the Sweep Reset Multivibrator stage so another sweep can be produced in the SINGLE SWEEP mode of operation.

Quiescently, Q454 is conducting hard and Q456 is held cut off. When the RESET button is pressed, CR451 is turned on. This clamps the junction of CR451-CR453 at +0.6 volt. CR453 and CR454 open and the base of Q454 drops to zero volts, turning it off. This turns Q456 on hard, pulling down its collector voltage. This negative-going step applied to C457-CR459 produces a negative pulse at the base of Q436 which is sufficient to reset the sweep reset multivibrator. This enables the sweep gate TD, and the next trigger pulse will produce another sweep on the display. C456 provides positive feedback with a long time-constant to keep Q454 off long enough to prevent switching transients from producing multiple sweeps.

Lamp Driver. In the SINGLE SWEEP MODE, the base of Q446 is connected through CR446, CR448 and CR449 to the collector of Q436. When Q436 is cut off, during holdoff time and until the RESET button is pressed, the base of Q446 is biased to cutoff. When the RESET button is pressed, Q436 is turned on and its collector voltage rises. This positive-going voltage allows Q446 to turn on (C446 controls turn-on time). Q446 collector voltage drops and the READY lamp turns on. The READY lamp remains on until the end of the sweep when Q436 is again turned off.

Alternate Operation

In alternate operation the indicator oscilloscope provides a sweep inhibit current to the emitter of Q410. Q410 provides a low impedance input and a voltage drive for the inhibit comparator, Q416 and Q424. A sweep inhibit current input of 1 mA or greater turns on Q410. This raises the base voltage of Q416, turning it on and turning Q424 off. The collector current of Q416 pulls the base of Q432 in a negative direction turning Q432 on and Q436 off to latch the sweep gate TD as described previously.

Delayed Sweep Operation

In this mode of operation the time-base in the left horizontal (A) compartment provides the sweep inhibit current to the emitter of Q410. The sweep inhibit circuit operates as described under Alternate Operation. The A time-base also provides a delay mode control voltage to the anode of CR462 in the sweep generator and CR357 in the trigger generator.

The delay mode control voltage causes CR462 to conduct, CR463 to turn off, CR464 to conduct and CR466 to turn off. This puts the B sweep in single sweep mode as described under Single Sweep Operation,

During sweep inhibit time Q424 is turned off. This turns off CR428, and with CR463 off the current from R428 turns on CR469. C469 now charges to about +1.5 volts, turning on Q468. This does not reset the sweep which is locked out by the conduction of Q416.

When sweep inhibit ends Q416 turns off, making the base of Q432 more positive. Q424 turns on to open CR469. C469 holds its charge long enough to allow Q468 to reset the sweep at the end of inhibit time. This action allows only one sweep after each time the sweep is inhibited.

The delay mode control voltage is also connected to the sweep gate TD, VR358, through CR357 and R356. With the A time-base B DELAY MODE in B TRIGGERABLE AFTER DELAY, the control voltage is about +3 volts, which does not cause CR357 to conduct. Thus, the sweep will wait for the first trigger after the delay interval to run. With the A time-base B DELAY MODE in B STARTS AFTER DELAY the control voltage is about +4.5 volts. This is sufficient to cause CR357 to conduct and increase the current through R356 to the sweep gate TD, VR358. Now the TD will change to its high-level state and start the sweep as soon as it is enabled by the sweep reset multi-vibrator at the end of inhibit current to Q410.

When the INDEPENDENT mode is selected by the A Plug-in DELAY MODE switch, the sweep inhibit is held at about the 0 mA level. The delay mode control voltage is

clamped to ground. The A time-base has no control over the B time-base and each operates as an independent Time-Base.

HORIZONTAL PREAMP

Operational Amplifier, U752, provides horizontal positioning control current to Q784, one side of paraphase amplifier Q784-Q794. Current is determined by settings of horizontal POSITION controls R774A and R774B. A positive-going sawtooth from Q534 drives the base of Q794, the other side of the paraphase amplifier. This produces a push-pull sawtooth signal at terminals CF and CE to drive the oscilloscope main-frame. X10 magnification is provided when relay K780 is switched on, K780 shunts Q784-Q794 emitter-to-emitter resistance with an adjustable resistance (R785) which allows a calibrated gain of 10. Additional RC networks in the MAG position correct for thermal time constants. Magnifier Registration control R795 balances the output to eliminate trace shift when switching from X1 to X10 magnification.

When the DISPLAY MODE selector is set to AMPLIFIER, U752 and the paraphase amplifiers Q784-Q794 act as an amplifier for external horizontal input signals applied to J1.

READOUT BLOCK

The Readout Block consists of switching resistors and a set of contacts operated by the X10 MAG switch. The switching resistors, selected by the setting of the Readout Switch (part of the TIME/DIV switch), are used to signal the Indicator Oscilloscope of the setting of the TIME/DIV switch.

Refer to Schematic Diagram 7, Timing Switch, at the rear of the manual to find the resistors associated with a particular setting of the TIME/DIV switch. The number 1, 2 or 5 is selected by resistors R704-R705-R706. The number of zeros is selected by resistors R711-R712-R713-R715. The TIME sub-unit (milli, micro, or nano) is selected by resistors R721-R722-R723-R724. R728-R729 select the symbol S (seconds). R701-R702 select the symbol \geq (greater than) when the VAR TIME/DIV knob is in the out (uncal) position. R715 is switched out by the X10 MAG to increase the displayed readout by a factor of 10.

SECTION 4

MAINTENANCE

Change information, if any, affecting this section will be found at the rear of the manual.

Introduction

This section of the manual contains maintenance information for use in preventive maintenance, corrective maintenance and troubleshooting of the 7B70.

PREVENTIVE MAINTENANCE

General

Preventive maintenance consists of cleaning, visual inspection, lubrication, etc. Preventive maintenance performed on a regular basis may prevent instrument breakdown and will improve the reliability of this instrument. The severity of the environment to which the 7B70 is subjected determines the frequency of maintenance. A convenient time to perform preventive maintenance is preceding recalibration of the instrument.

Cleaning

The 7B70 should be cleaned as often as operating conditions require. Accumulation of dirt in the instrument can cause overheating and component breakdown. Dirt on components acts as an insulating blanket and prevents efficient heat dissipation. It may also provide an electrical conduction path.

The covers of the indicator oscilloscope minimize the amount of dust which reaches the interior of the 7B70. Operation of the system without the indicator oscilloscope covers in place necessitates more frequent cleaning. When the 7B70 is not in use, it should be stored in a protected location such as a dust-tight cabinet.



Avoid the use of chemical cleaning agents which might damage the plastics used in this instrument. Avoid chemicals which contain benzene, toluene, xylene, acetone or similar solvents.

Exterior. Loose dust accumulated on the outside of the 7B70 can be removed with a soft cloth or small paint brush. The paint brush is particularly useful for dislodging dirt on and around the front-panel controls. Dirt which remains can be removed with a soft cloth dampened in a mild detergent and water solution. Abrasive cleaners should not be used.

Interior. Dust in the interior of the instrument should be removed occasionally due to its electrical conductivity under high-humidity conditions. The best way to clean the interior is to blow off the accumulated dust with dry, low-velocity air. Remove any dirt which remains with a soft paint brush or a cloth dampened with a mild detergent and water solution. A cotton-tipped applicator is useful for cleaning in narrow spaces.

Visual Inspection

The 7B70 should be inspected occasionally for such defects as broken connections, broken or damaged circuit boards, improperly seated transistors or relay, and heat-damaged parts.

The corrective procedure for most visible defects is obvious; however, particular care must be taken if heat-damaged components are found. Overheating usually indicates other trouble in the instrument; therefore, it is important that the cause of overheating be corrected to prevent a recurrence of the damage.

Transistor Checks

Periodic checks of the transistors in the 7B70 are not recommended. The best check of transistor performance is actual operation in the instrument. More details on checking transistor operation are given under Troubleshooting.

Recalibration

To ensure accurate measurements, check the calibration of this instrument after each 1000 hours of operation or every six months if used infrequently. In addition, replacement of components may necessitate recalibration of the affected circuits. Complete calibration instructions are given in Section 5.

The Performance Check/Calibration Procedure can also be helpful in localizing certain troubles in the instrument. In some cases, minor troubles may be revealed and/or corrected by calibration.

TROUBLESHOOTING

Introduction

The following information is provided to facilitate troubleshooting of the 7B70. Information contained in other sections of this manual should be used along with the following information to aid in locating the defective component. An understanding of the circuit operation is very helpful in locating troubles. See the Circuit Description section for complete information.

Troubleshooting Aids

Diagrams. Circuit diagrams are given on foldout pages in Section 7. The component number and electrical value of each component in this instrument are shown on the diagrams. Important voltages and waveforms are also shown on the diagrams.

Switch Cam Identification. Switch cam numbers shown on the diagrams indicate the position of the cam in the complete switch assembly. The cams are numbered from the front, or mounting end of the switch, toward the rear.

Resistor Color-Code. In addition to the brown composition resistors, some metal-film resistors and some wire-wound resistors are used in the 7B70. The resistance values of wire-wound resistors are printed on the body of the component. The resistance values of composition resistors and metal-film resistors are color-coded on the components (some metal-film resistors may have the value printed on the body) with EIA color code. The color code is read starting with the stripe nearest the end of the resistor. Composition resistors have four stripes which consist of two significant figures, a multiplier and a tolerance value (see Fig. 4-1). Metal-film resistors have five stripes consisting of three significant figures, a multiplier and a tolerance value.

Capacitor Marking. The capacitance values of common disc capacitors and small electrolytics are marked in microfarads on the side of the component body. The white ceramic capacitors used in the 7B70 are color coded in picofarads using a modified EIA code (see Fig. 4-1).

Diode Color Code. The cathode end of each glass-encased diode is indicated by a stripe, a series of stripes or a dot. For most silicon or germanium diodes with a series of

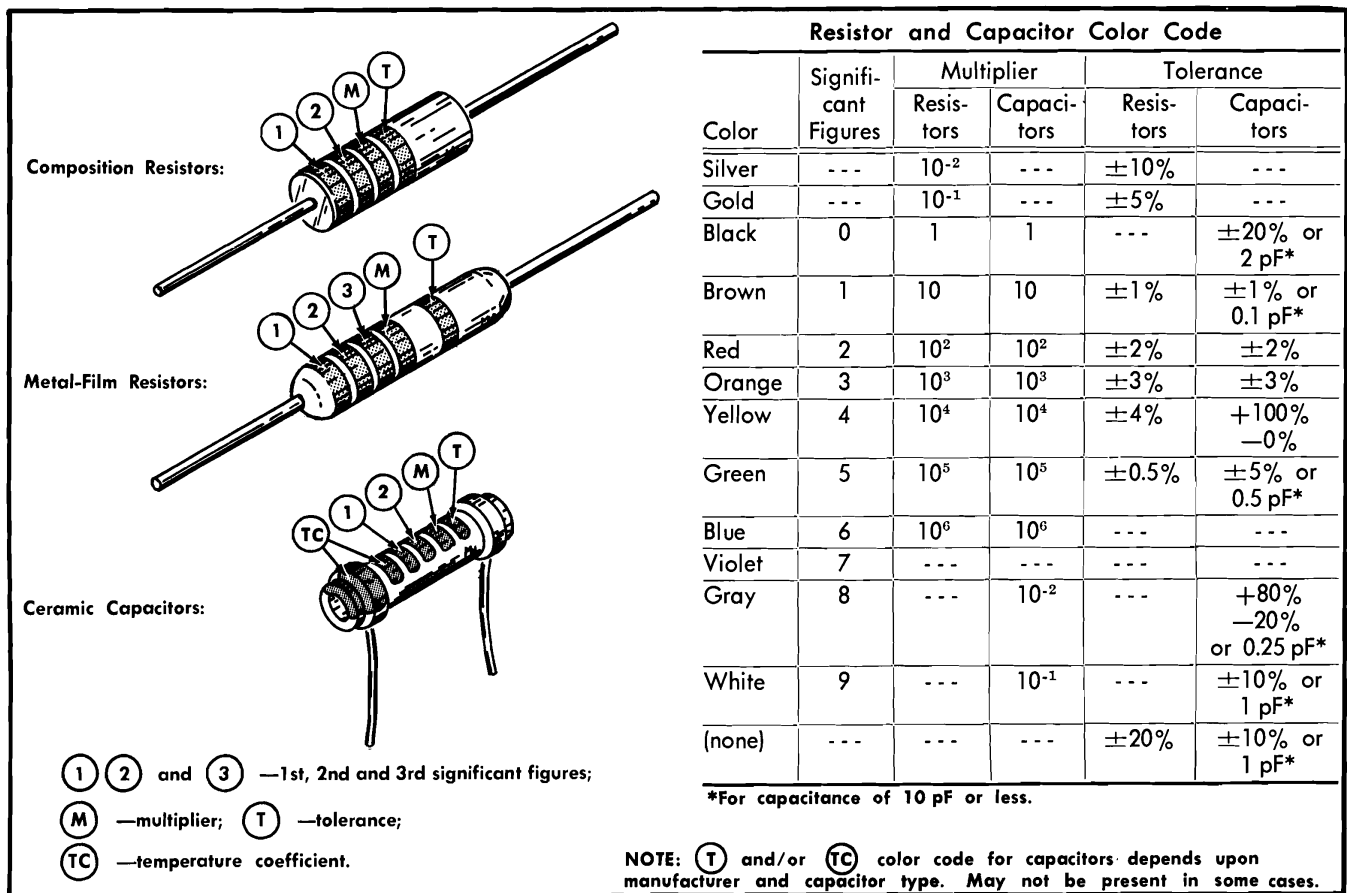

Fig. 4-1. Color-code for resistors and ceramic capacitors.

stripes, the color code also indicates the type of diode or identifies the Tektronix Part Number using the resistor color code system (e.g., a diode color-coded blue- or pink-brown-gray-green indicates Tektronix Part Number 152-0185-00). The cathode and anode ends of metal-encased diodes can be identified by the diode symbol marked on the body.

Troubleshooting Equipment

The following equipment is useful for troubleshooting the 7B70:

1. Transistor Tester

Description: Tektronix Type 576 Transistor-Curve Tracer or equivalent.

Purpose: To test the semiconductors used in this instrument.

2. Volt-ohmmeter

Description: 20,000 ohms/volt. 0-500 volts DC. Accurate within 3%. Test probes must be well insulated.

Purpose: To measure voltages and resistances.

3. Test Oscilloscope

Description: DC to 200 MHz frequency response, 5 millivolts to 5 volts/division deflection factor. Use a 10X probe.

Purpose: To check waveforms in the instrument.

4. Plug-In Extender

Description: Rigid plug-in extender, Tektronix Part number 067-0589-00.

Purpose: Permits operation of the unit outside the plug-in compartment for better accessibility during troubleshooting.

Troubleshooting Techniques

This troubleshooting procedure is arranged in an order which checks the simple trouble possibilities before proceeding with extensive troubleshooting. The first few checks ensure proper connection, operation and calibration. If the trouble is not located by these checks, the remaining steps aid in locating the defective component. When the defective component is located, it should be replaced following the replacement procedures given under Corrective Maintenance.

1. Check Control Settings. Incorrect control settings can indicate a trouble that does not exist. If there is any question about the correct function or operation of any control, see the Operating Instructions section.

2. Check Associated Equipment. Before proceeding with troubleshooting of the 7B70, check that the equipment used with this instrument is operating correctly. Check that the signal is properly connected and that the probe cable is not defective. The indicator oscilloscope and vertical plug-in unit can be checked for proper operation by substituting another time-base unit which is known to be operating properly (preferably another 7B70 or similar unit). If the trouble persists after substitution, the indicator oscilloscope and/or vertical plug-in unit is defective.

3. Check Instrument Calibration. Check the calibration of this instrument, or the affected circuit if the trouble exists in one circuit. The apparent trouble may only be a result of misadjustment and may be corrected by calibration. Complete calibration instructions are given in the Calibration section.

4. Visual Check. Visually check the portion of the instrument in which the trouble is located. Many troubles can be located by visual indications such as unsoldered connections, broken wires, damaged components, etc.

5. Isolate Trouble to a Circuit. To isolate a trouble to a circuit, note the trouble symptom. The symptom often indicates the circuit in which the trouble is located. For example, if normal triggering can be obtained in the INT mode but cannot be obtained in the EXT mode, the external trigger amplifier or the SOURCE switch is probably at fault. When trouble symptoms appear, use the front-panel controls and the CRT display to try to isolate the trouble to one circuit. When the trouble appears in more than one circuit, check all affected circuits by taking voltage and waveform readings.

Fig. 4-2 provides a guide to aid in locating a defective circuit. This chart does not include checks for all possible defects; use steps 6 and 7 for further troubleshooting. Start from the top of the chart and perform the given checks on the left side of the page until a step is found which is not correct. Further checks and/or the circuit in which the trouble is probably located are listed to the right of this step.

After the defective circuit has been located, proceed with steps 6 and 7 to locate the defective component(s).

6. Check Voltages and Waveforms. Often the defective components can be located by checking for the correct

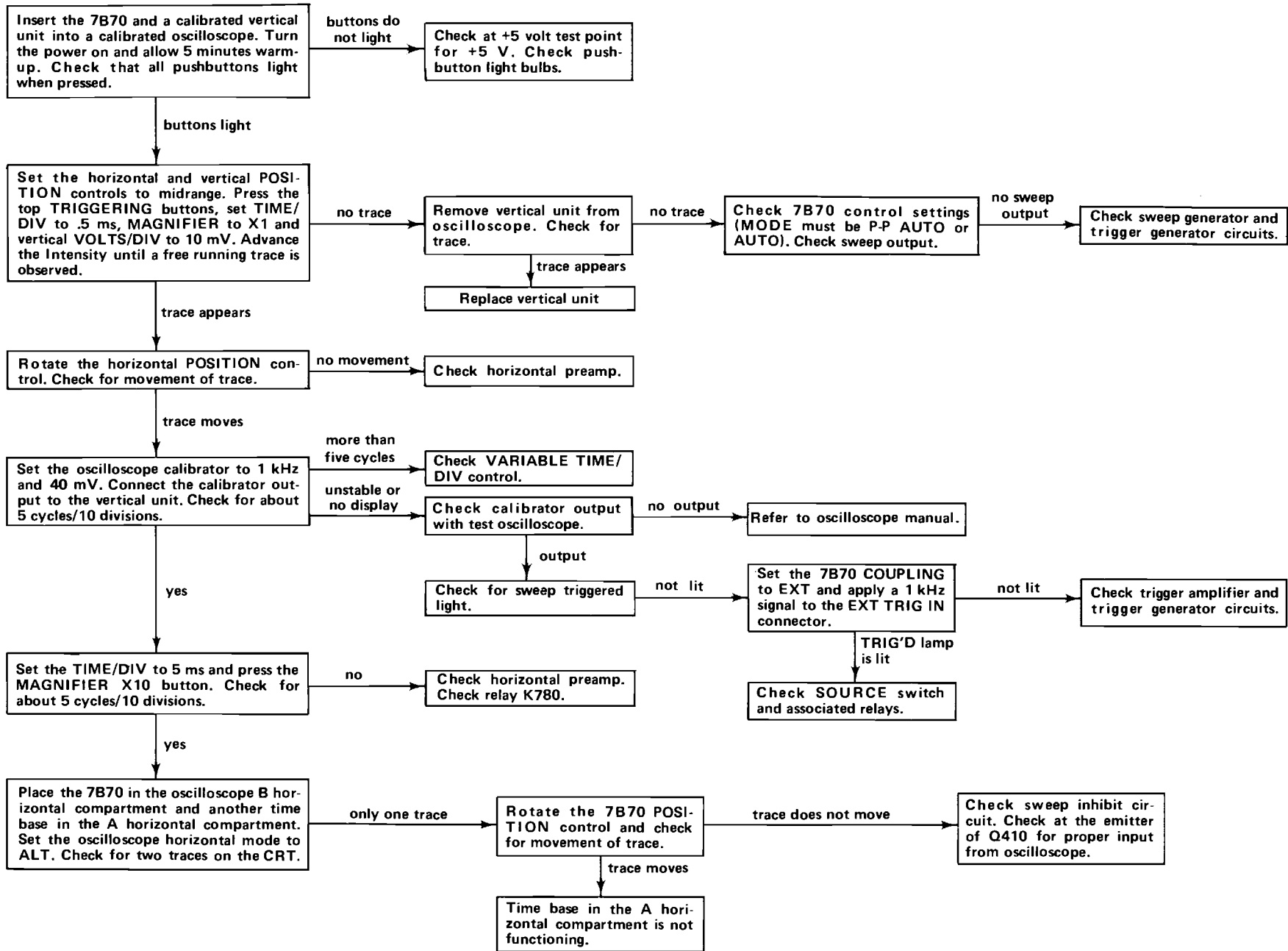

Fig. 4-2. Troubleshooting chart for the 7B70.

voltage or waveform in the circuit. Typical voltages and waveforms are given on the diagrams.

CAUTION

Do not clamp probe to pin connectors as this may break or damage the connectors.

NOTE

Voltages and waveforms given on the diagrams are not absolute and may vary slightly between instruments. To obtain operating conditions similar to those used to take these readings, see the first diagram page.

7. Check Individual Components. The following procedures describe methods of checking individual components in the 7B70. Components which are soldered in place are best checked by disconnecting one end. This isolates the measurement from the effects of surrounding circuitry.

A. RELAYS. The 7B70 uses two types of relays. The eight pin DPDT relay is symmetrical and may be replaced in its socket facing either direction. The five pin SPDT relay will mate with its socket in one direction only. These relays, which are plugged into the circuit board, may be removed and checked. Using an ohmmeter, check for a DC resistance of 600 ohms across the coil. Each relay can be actuated by applying 15 volts across the coil. With the relay actuated, check the normally open contacts for continuity. When returning the relays to the circuit board, place the five pin relay in the five pin socket and the eight pin relays in the eight pin sockets.

B. TRANSISTORS. The best check of transistor operation is actual performance under operating conditions. If a transistor is suspected of being defective, it can best be checked by substituting a new component or one which has been checked previously. However, be sure that circuit conditions are not such that a replacement transistor might also be damaged. If substitute transistors are not available, use a dynamic tester (such as Tektronix Type 576).

C. DIODES. A diode can be checked for an open or for a short circuit by measuring the resistance between terminals with an ohmmeter set to the R X 1k scale. The diode resistance should be very high in one direction and very low when the meter leads are reversed. Do not check tunnel diodes or back diodes with an ohmmeter.

CAUTION

Do not use an ohmmeter scale that has a high internal current. High currents may damage the diode.

D. RESISTORS. Resistors can be checked with an ohmmeter. Check the Electrical Parts List for the tolerance of the resistors used in this instrument.

E. INDUCTORS. Check for open inductors by checking continuity with an ohmmeter. Shorted or partially shorted inductors can usually be found by checking the waveform response when high-frequency signals are passed through the circuit. Partial shorting often reduces high-frequency response.

F. CAPACITORS. A leaky or shorted capacitor can best be detected by checking the resistance with an ohmmeter on the highest scale. Do not exceed the voltage rating of the capacitor. The resistance reading should be high after initial charge of the capacitor. An open capacitor can best be detected with a capacitance meter or by checking whether the capacitor passes AC signals.

8. Repair and Readjust the Circuit. If any defective parts are located, follow the replacement procedures given in this section. Be sure to check the performance of any circuit that has been repaired or that has had any electrical components replaced.

CORRECTIVE MAINTENANCE

General

Corrective maintenance consists of component replacement and instrument repair. Special techniques required to replace components in this instrument are given here.

Obtaining Replacement Parts

Standard Parts. All electrical and mechanical part replacements for the 7B70 can be obtained through your local Tektronix Field Office or representative. However, many of the standard electronic components can be obtained locally in less time than is required to order them from Tektronix, Inc. Before purchasing or ordering replacement parts, check the parts list for value, tolerance, rating and description.

NOTE

When selecting replacement parts, it is important to remember that the physical size and shape of a component may affect the performance in the instrument, particularly at high frequencies. All replacement parts should be direct replacements unless it is known that a different component will not adversely affect instrument performance.

Special Parts. In addition to the standard electronic components, some special parts are used in the 7B70. These

Maintenance—7B70 (SN B205000 and Up)

parts are manufactured or selected by Tektronix, Inc. to meet specific performance requirements, or are manufactured for Tektronix, Inc. in accordance with our specifications. These special parts are indicated in the parts list by an asterisk preceding the part number. Most of the mechanical parts used in this instrument have been manufactured by Tektronix, Inc. Order all special parts directly from your local Tektronix Field Office or representative.

Ordering Parts. When ordering replacement parts from Tektronix, Inc., include the following information:

1. Instrument Type.
2. Instrument Serial Number.
3. A description of the part (if electrical, include circuit number).
4. Tektronix Part Number.

Soldering Techniques

WARNING

Disconnect the instrument from the power source before soldering.

Circuit Boards. The components mounted on the circuit boards in the amplifier can be replaced using normal circuit board soldering techniques. Keep the following points in mind when soldering on the circuit boards.

1. Use a pencil-type soldering iron with a power rating from 15 to 50 watts.
2. Apply heat from the soldering iron to the junction between the component and the circuit board.
3. Heat-shunt the lead of the component by means of a pair of long-nosed pliers.
4. Avoid excessive heating of the junction with the circuit board, as this could separate the circuit board wiring from the laminate.
5. Use electronic grade 60-40 tin-lead solder.
6. Clip off any excess lead length extending beyond the circuit board and clean off any residual flux with a flux-removing solvent. Be careful that the solvent does not remove any printing from the circuit board.

Metal Terminals. When soldering metal terminals (e.g., switch terminals, potentiometers, etc.), use 60-40 tin-lead solder and a 15 to 50 watt soldering iron. Observe the following precautions when soldering metal terminals:

1. Apply only enough heat to make the solder flow freely.
2. Apply only enough solder to form a solid connection. Excess solder may impair the function of the part.
3. If a wire extends beyond the solder joint, clip off the excess.
4. Clean the flux from the solder joint with a flux-removing solvent.

Component Replacement

WARNING

Disconnect the equipment from the power source before replacing components.

Relay Replacement. The relays in the 7B70 are manufactured by Tektronix Inc. If a relay fails, a replacement may be ordered from your local Tektronix Field Office or representative. The five pin relay sockets on the circuit board will accept only the five pin SPDT relay. It is possible, however, to place a five pin SPDT relay in an eight pin socket intended for use with one of the eight pin relays. This would not damage the instrument or the relay, but would cause a malfunction of the instrument. The eight pin DPDT relays may be placed in their sockets facing either direction, as these relays are symmetrical.

CAUTION

The relays used in this instrument can be damaged by heat. Do not apply a soldering iron to the relay socket until the relay has been removed from the socket.

Transistor Replacement. Transistors should not be replaced unless actually defective. If removed from their sockets during routine maintenance, return them to their original sockets. Unnecessary replacement of transistors may effect the calibration of this instrument. When transistors are replaced, check the operation of that part of the instrument which may be affected.

Replacement transistors should be of the original type or a direct replacement. Remount the transistors in the same manner as the original. Fig. 4-3 shows the lead configurations of the transistors used in this instrument. This view is

as seen from the bottom of the transistor. When replacing transistors, check the manufacturer's basing diagram for correct basing.

Interconnecting Pins and Pin Socket Replacement. Two types of mating connectors are used for these interconnecting pins. If the mating connector is mounted on a plug-on circuit board, a special socket is soldered into the board. If the mating connector is on the end of a lead, a pin connector is used to mate with the interconnecting pin. The following information provides the replacement procedure for the various types of pins and pin sockets.

CAUTION

When removing the stub of a broken pin connector, it is important not to disturb the old ferrule which is swaged into the circuit board. Use the minimum amount of heat necessary to remove the pin. The new pins are supplied with ferrules intact. Remove the ferrule from the new pin before inserting the pin into the old ferrule in the circuit board. The old ferrule may be reamed out with a .031 drill if necessary. A circuit board pin replacement kit including necessary tools, instructions and replacement pins is available from Tektronix, Inc. Order Tektronix Part No. 040-0542-00.

A. CIRCUIT BOARD PINS. To replace a pin which is mounted on a circuit board, first disconnect any pin connectors. Unsolder the damaged pin and pull it out of the circuit board. Press the new pin into the ferrule in the circuit board. (Notice that the ferrule is not centered on the pin; be sure the replacement pin is positioned in the same manner as the original.) Solder the pin on both sides of the circuit board. If the pin was bent at an angle to mate with a connector, bend the new pin to match the associated pins. The inside radius of this bend should not be less than 0.025 inch.

B. CIRCUIT BOARD PIN SOCKETS. The pin sockets on the circuit boards are soldered to the rear of the board. To replace the sockets, first unsolder the socket (use a vacuum-type desoldering tool to remove excess solder). Straighten the tabs on the socket to remove it from the hole in the circuit board. Place the new socket in the circuit board hole and press the tabs down against the board. Solder the socket tabs to the circuit board.

NOTE

The spring tension of the terminal sockets ensures a good connection between the circuit board and the pin. This spring tension can be destroyed by using the pin sockets as a connecting point for spring-loaded probe tips, alligator clips, etc.

C. END-LEAD PIN CONNECTORS. The pin connectors used to connect the wires to the circuit board pins are

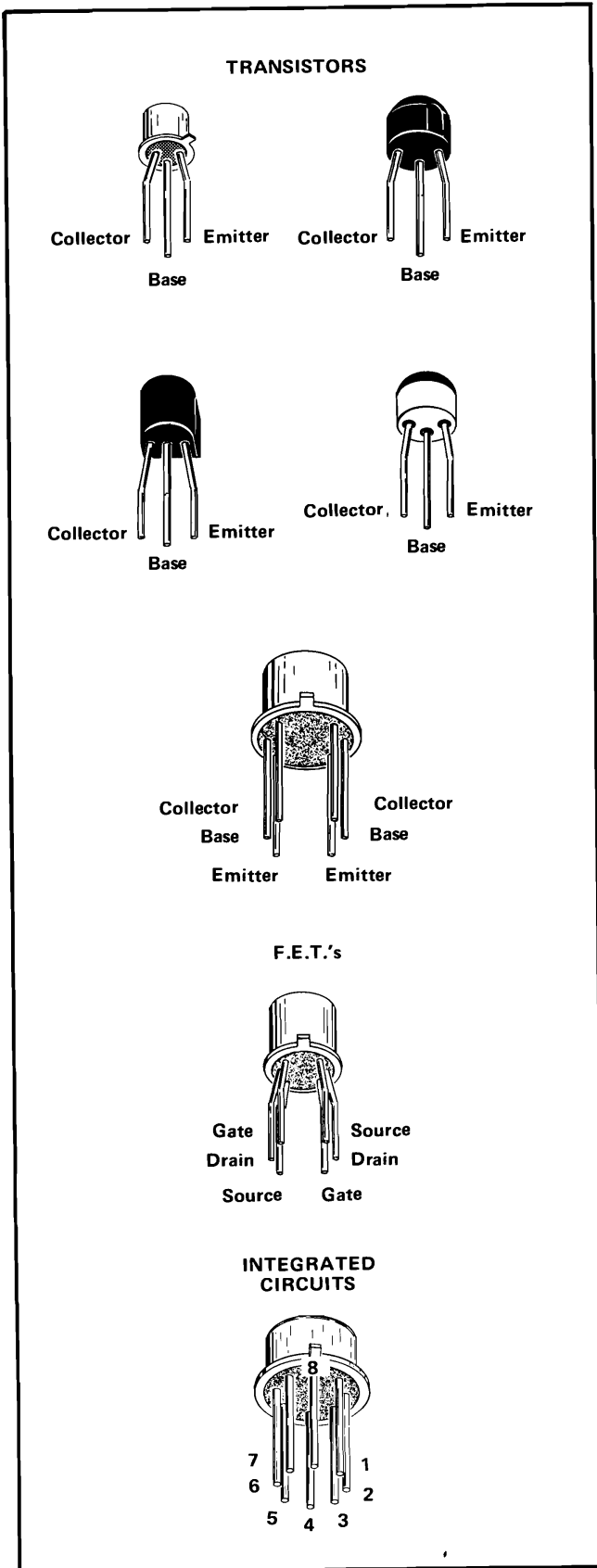

Fig. 4-3. Electrode configuration of transistors and integrated circuits used in this instrument.

clamped to the ends of the associated leads. To replace a damaged pin connector, first remove the old pin connector from the end of the lead. Clamp the new pin connector to the end of the lead. Some of the pin connectors are grouped together and mounted in a plastic holder. These connectors are removed and re-installed as a unit. To provide correct orientation of this multi-connector when it is replaced, an arrow is stamped on the circuit board and a matching arrow is moulded into the plastic housing of the multi-pin connector.

Switch Replacement. Two types of switches are used in the 7B70. The pushbutton switches and the cam-type switch should be replaced as a unit if damaged. The following special maintenance information is provided for the cam-type and pushbutton type switches.

CAUTION

Repair of the cam switch should only be undertaken by skilled maintenance personnel. Switch alignment and contact spacing must be carefully maintained for proper operation of the switch. A cam-type switch repair kit including the necessary tools, instructions and replacement contacts is available from Tektronix, Inc. Order Tektronix Part No. 040-0541-00.

A. CAM-TYPE SWITCH. The cam-type switch (TIME/DIV) consists of a rotating cam, which is turned by the front panel knob, and a set of contacts mounted on an adjacent circuit board. These switch contacts are actuated by lobes on the cam. The TIME/DIV switch can be disassembled for inspection, cleaning, repair or replacement as follows:

1. Remove the four screws which hold the metal cover over the switch. The switch is now open for inspection or cleaning.

2. To completely remove the switch, loosen the set screw on the collar securing the VARIABLE shaft to the VARIABLE potentiometer and pull the shaft completely out the front of the unit. Loosen the two set screws on the TIME/DIV knob and remove the knob. Remove the plastic bushing from the access hole for the TIME/DIV shaft.

3. Remove the sweep generator board by loosening the securing screws and carefully lifting out.

4. Remove the six screws which hold the cam switch to the interface circuit board and remove the cam switch.

5. To remove the cam from the front support block, remove the retaining ring from the shaft on the front of the switch and slide the cam out of the support block. Do not lose the small detent roller.

6. To replace defective switch contacts, unsolder the damaged contact and clean the solder from the hole in the circuit board. Following the procedure given in the instruction sheet included with the cam switch replacement kit,

use the alignment tool to position the new contact in place. Solder the contact using the soldering techniques given previously in this section of the manual.

7. To re-assemble the switch, reverse the above procedure.

B. PUSH-BUTTON SWITCHES. Use the following procedure to replace the five pushbutton switches:

1. Loosen the set screws and remove the POSITION, LEVEL/SLOPE, TIME/DIV, VARIABLE, and Amplifier VARIABLE knobs.

2. Remove the front panel to gain access to the switch mounting screws.

3. To remove the DISPLAY MODE switch, remove the phillips head screw and disconnect the multi-pin connector.

4. To remove the MAGNIFIER switch, remove the phillips head screw and disconnect the multi-pin connector.

5. To remove the TRIGGERING switches, remove the two phillips head screws from each of the MODE, COUPLING and SOURCE switches. Disconnect the following multi-pin connectors: AMPLIFIER VARIABLE, DISPLAY MODE, SWP CAL, POSITION, LEVEL/SLOPE, TRIG'D and MAGNIFIER. Disconnect the two pin connectors from the SOURCE and COUPLING switches. Remove the four screws securing the front of the unit to the top and bottom and remove the front of the unit. Remove the TRIGGERING switches (the sweep generator board may have to be removed to take out the TRIGGERING MODE switch).

Light Bulb Replacement. To replace the light bulbs follow the above procedure to remove the switches. Remove the screw and cover from the back of the switch to expose the light bulb. Unsolder the two leads and remove the light bulb. Cut the leads of the replacement light bulb to the same length as those of the old bulb. Place insulating sleeves over the leads and replace the new bulb in the exact position of the old bulb.

Reassemble by reversing the above procedure.

Instrument Repackaging

If the 7B70 is to be shipped for long distances by commercial means of transportation, it is recommended that the instrument is repackaged in the original manner for maximum protection. The original shipping carton can be saved and used for this purpose or new shipping cartons can be obtained from Tektronix, Inc. through your local Tektronix Field Office or representative. Repackaging information can be found in the Mechanical Parts Illustrations at the rear of this manual.

NOTE

The plug-ins should not be shipped installed in an oscilloscope. The oscilloscope packaging material is not designed to protect the plug-ins.

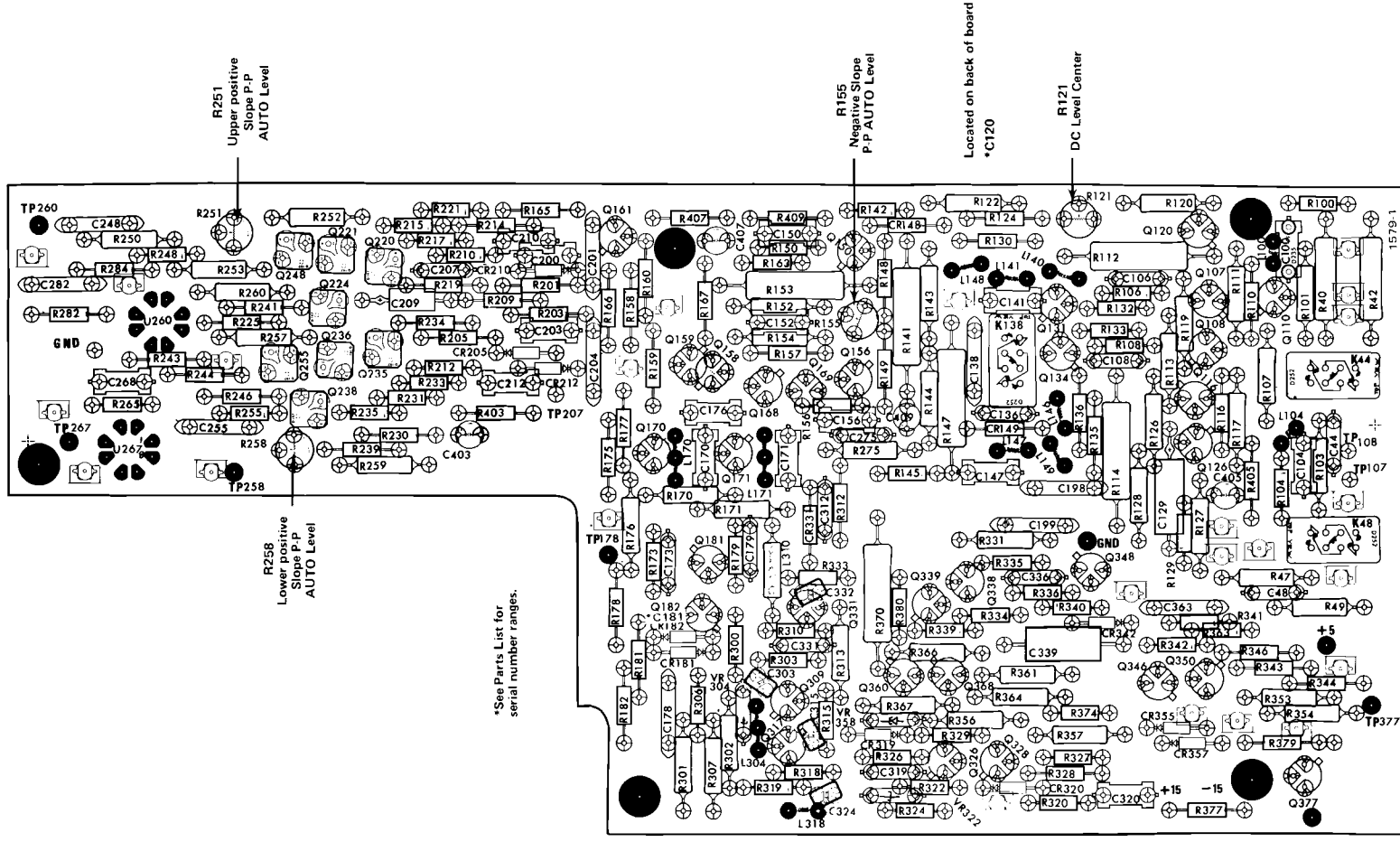

Fig. 4-4. Trigger Generator board (front view) showing location of components and adjustments.

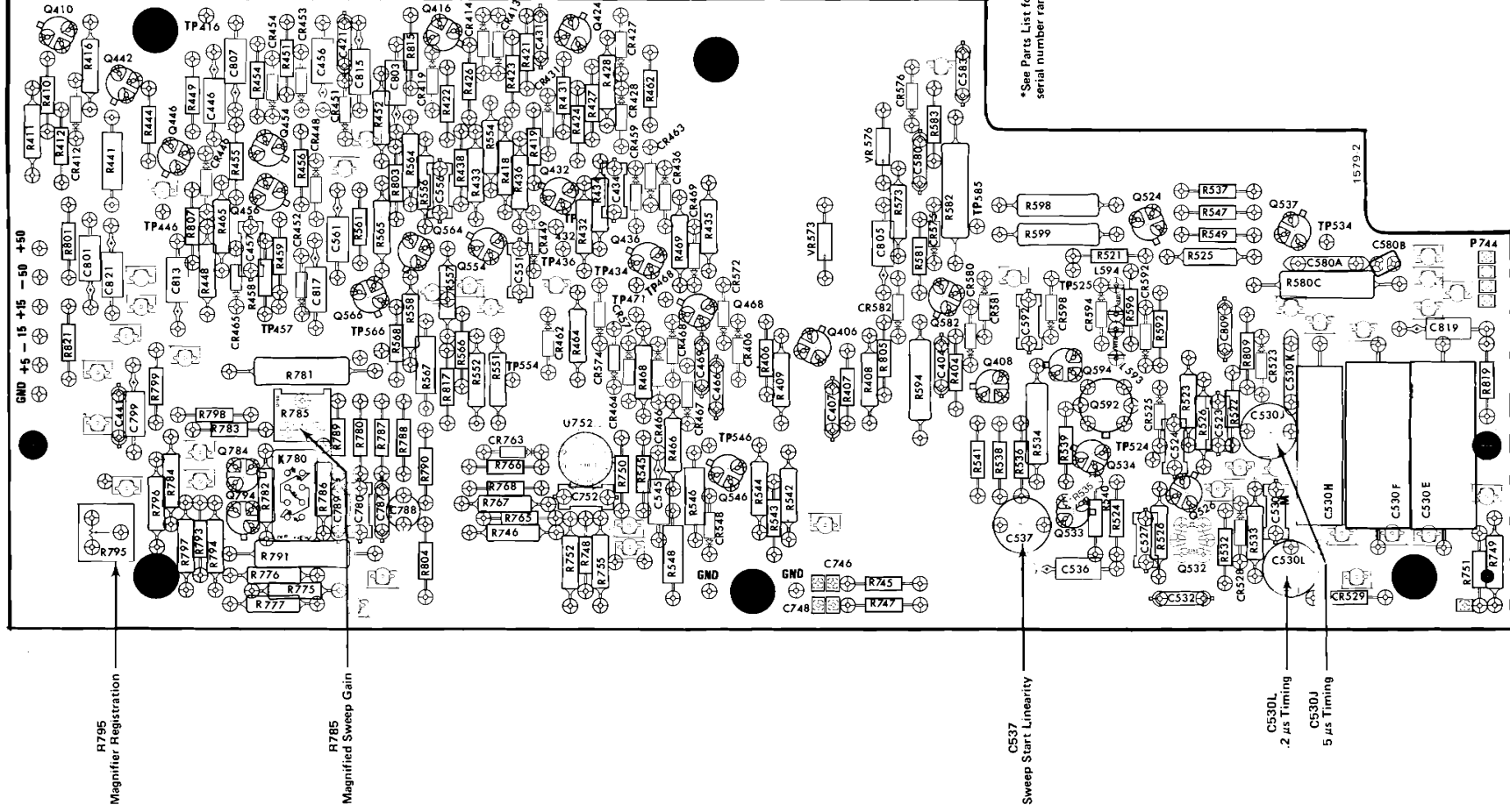

Fig. 4-5. Time Base board (front view) showing location of components and adjustments.

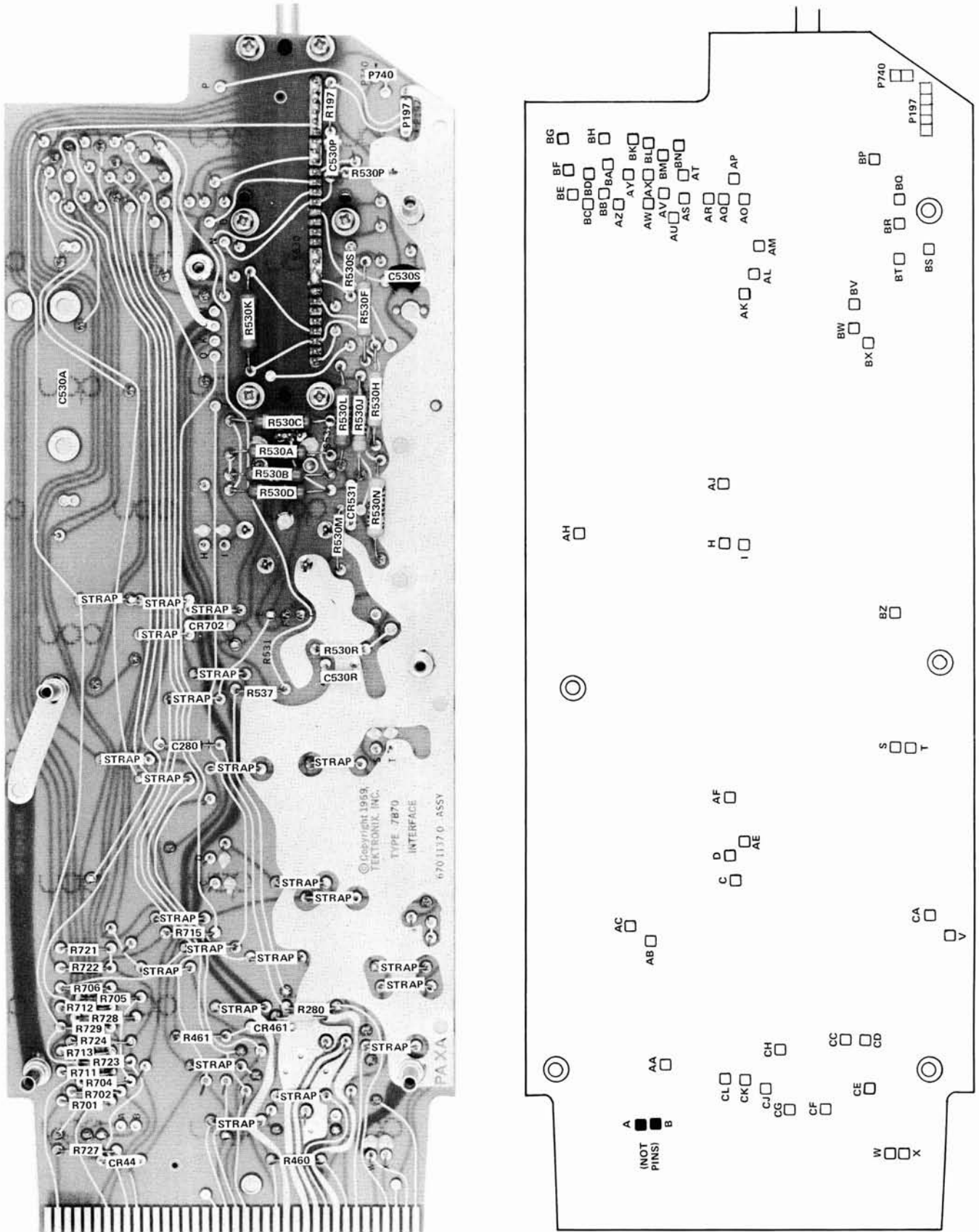

Fig. 4-6. Interface board (left side) showing location of components and connections.

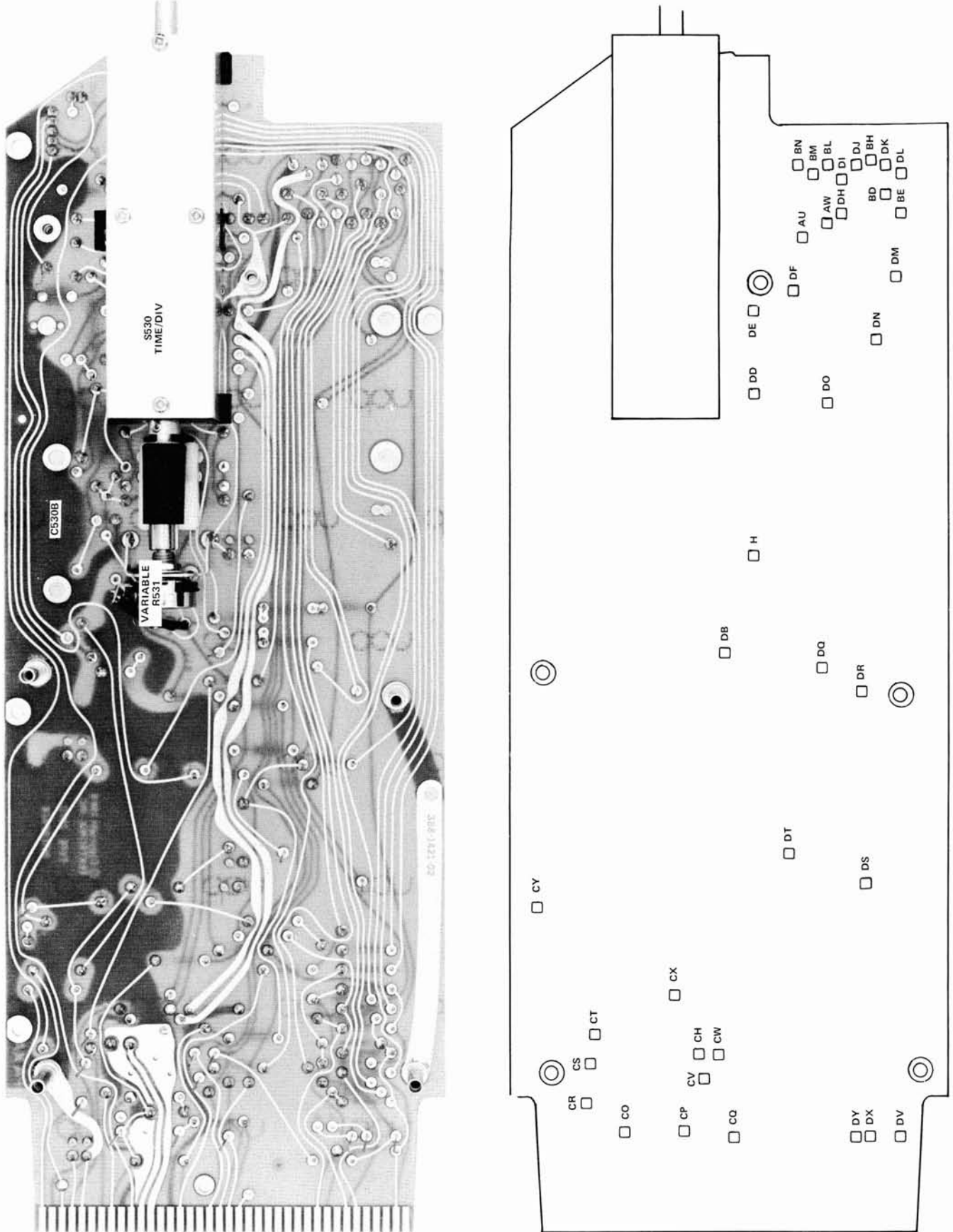

Fig. 4-7. Interface board (right side) showing location of components and connectors.

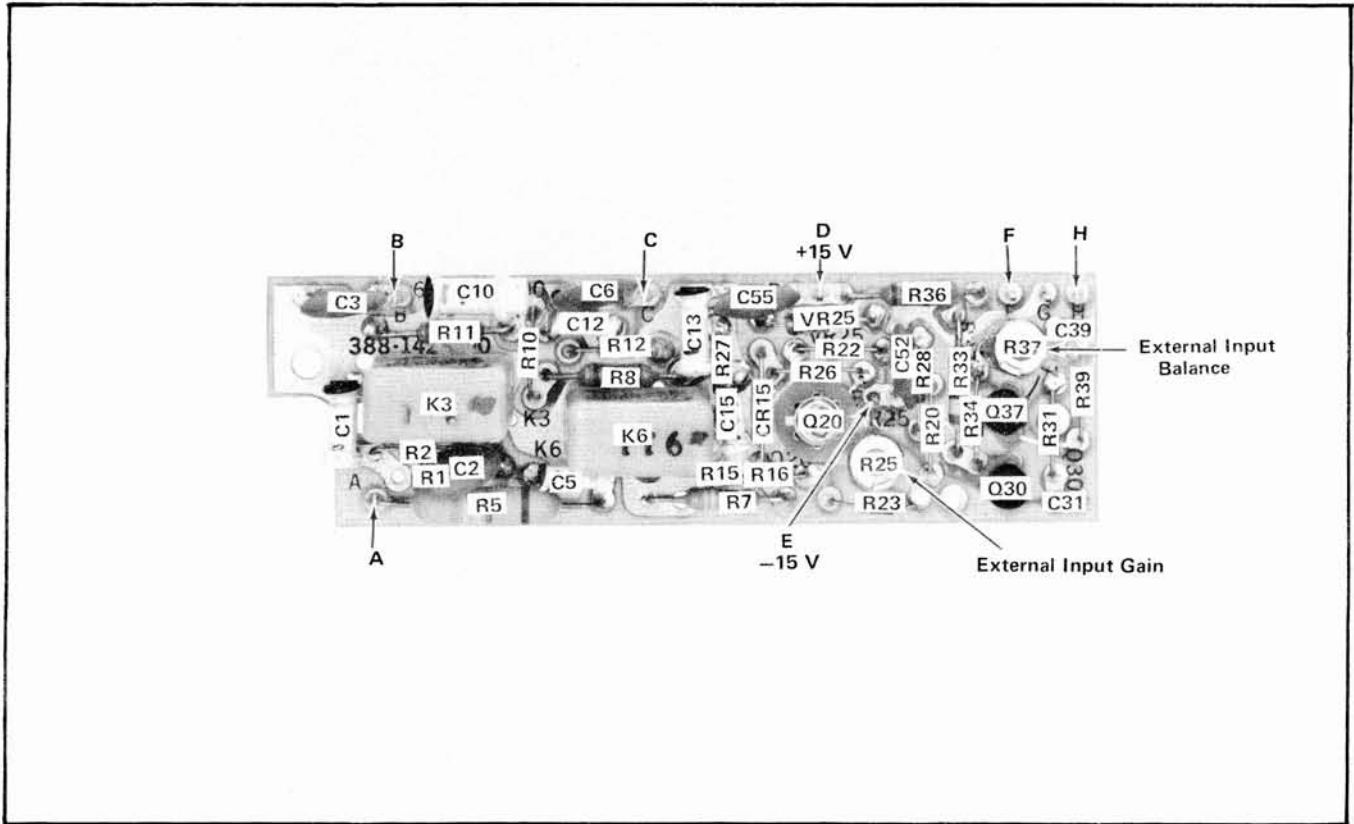

Fig. 4-8. External board showing location of components and connectors.

SECTION 5

PERFORMANCE CHECK / CALIBRATION

Change information, if any, affecting this section will be found at the rear of the manual.

Introduction

To assure instrument accuracy, check the calibration of the 7B70 every 1000 hours or every six months if used infrequently. Before calibration, thoroughly clean and inspect this instrument as outlined in the Maintenance Section.

The complete Performance Check/Calibration Procedure can be used to check instrument performance without removing side covers or making internal adjustments by performing all portions except the ADJUST part of the steps. Screwdriver adjustments which are accessible without removing the covers are adjusted as part of the performance check procedure. A note titled PERFORMANCE CHECK ONLY gives instructions which are applicable only to the performance check procedure.

Completion of each step in the complete Performance Check/Calibration Procedure insures that this instrument meets the electrical specifications given in Section 1. For best overall instrument performance, when performing a complete calibration procedure, make each adjustment to the exact setting even if the CHECK is within the allowable tolerance.

A Short-Form Procedure is given prior to the complete procedure. To facilitate instrument calibration, for the experienced calibrator, the Short-Form Procedure lists the calibration adjustment necessary for each step and the applicable tolerances. This procedure also includes the step number and title as listed in the complete Performance Check/Calibration Procedure and the page number on which each step begins. Therefore, the Short-Form Procedure can be used as an index to locate a step in the complete procedure. Another feature of the Short-Form Procedure is the spaces provided to record performance data or to check off steps as they are completed. This procedure may be reproduced and used as a permanent record of instrument calibration.

NOTE

All waveforms shown in this procedure were taken with a Tektronix Oscilloscope Camera System. Limits, tolerances and waveforms in this procedure are given as calibration guides and should not be interpreted as instrument specifications except as stated in Section 1.

A partial calibration is often desirable after replacing a component or to touch up an adjustment of a portion of the instrument between major recalibrations. For partial calibration, set the controls as given under Preliminary Control Settings and start with the desired check or checks. If any controls need to be changed from the preliminary settings for this portion of the calibration procedure, they are listed under the heading Partial Procedure. To prevent unnecessary recalibration of other parts of the instrument, readjust only if the tolerance given in the CHECK part of the step is not met. If readjustment is necessary, also check the calibration of any steps listed in the INTERACTION part of the step.

TEST EQUIPMENT REQUIRED

General

The following test equipment and accessories, or its equivalent, are required for complete calibration of the 7B70. Specifications given are the minimum necessary for accurate calibration. Therefore, some of the recommended equipment may have specifications which exceed those given. All test equipment is assumed to be correctly calibrated and operating within the given specifications. If equipment is substituted, it must meet or exceed the specifications of the recommended equipment.

Special Tektronix calibration fixtures are used in this procedure only where they facilitate calibration. These special calibration fixtures are available from Tektronix, Inc. Order by part number through your local Tektronix Field Office or representative.

1. Test time-base compatible with the Tektronix 7700-series oscilloscope. 7B71 used in these checks.

2. Vertical amplifier (2 each) for use with Tektronix 7000-series oscilloscopes. Bandwidth, 200 MHz or greater; deflection factor, 5 volts to less than 50 millivolts. Tektronix 7A16A used in these checks (a single 7A12 may be used instead of the two 7A16A amplifiers).

3. Oscilloscope. Tektronix 7700 or 7900-series. 7704 used in these checks except step 24 (7904).

4. Plug-in extender (Rigid). Tektronix Part Number 067-0589-00.

Performance Check/Calibration—7B70 (SN B205000 and Up)

5. Low-frequency sine-wave generator. Frequency range, 20 hertz to greater than 50 kilohertz; output amplitude, 150 millivolts to 5 volts. For example, General Radio Model 1310-A Oscillator.

6. Constant amplitude sine-wave generator. Reference frequency, 50 kilohertz; frequency range, 10 megahertz to 100 megahertz; output amplitude variable from 150 millivolts to 5 volts. Tektronix Type 191 recommended.

7. Time-mark generator. Marker outputs, five seconds to five nanoseconds; marker accuracy, within 0.1%. Tektronix 2901 Time-Mark Generator recommended.

8. Calibration Fixture, Constant Amplitude Signal Generator. Reference frequency, 3 megahertz; frequency range, 65 megahertz to above 200 megahertz; output amplitude, 0.5 to 5 volts peak to peak into 50 ohms; amplitude accuracy, output amplitude constant within 1% or 3 megahertz reference as output frequency changes. Tektronix Part Number 067-0532-01.

9. Standard Amplitude Calibrator. Frequency, 1 kHz; output amplitude, 0.5 mV to 50 V peak to peak in a 1-2-5 step sequence; amplitude accuracy, $\pm 0.25\%$. Tektronix calibration fixture 067-0502-00 recommended.

10. 10X probe. Tektronix Type P6053A recommended.

11. Cable (2 each). Connectors, BNC; Impedance, 50 ohms; length, 42 inches. Tektronix Part Number 012-0057-01.

12. BNC T connector. Tektronix Part Number 103-0030-00.

13. 50 ohm feedthrough termination (2 each). Tektronix Part Number 011-0049-01.

14. Adapter. GR to BNC female. Tektronix Part Number 017-0063-00.

15. 1X Probe (2 each). Tektronix P6011 probe recommended.

Optional Equipment

1. Plug-In Extension (Flexible), Tektronix Part Number 067-0616-00 (when used with vertical plug-in, allows easier access to adjustments on left side of 7B70).

SHORT-FORM PROCEDURE

7B70 _____

Calibration Date _____

Calibrated By _____

1. Adjust Upper Positive Slope P-P AUTO Level (R251) Page 5-5

Requirement: Stable triggering on a 0.5 division 50 kHz signal with the LEVEL/SLOPE control set to 11:30.

Performance: Correct _____ ; Incorrect _____ .

2. Adjust Lower Positive Slope P-P AUTO Level (R258) Page 5-5

Requirement: Stable triggering on a 0.5 division 50 kHz signal with the LEVEL/SLOPE control set to 6:30.

Performance: Correct _____ ; Incorrect _____ .

3. Adjust Negative Slope P-P AUTO Level (R155) Page 5-5

Requirement: Stable triggering on a 0.5 division 50 kHz signal with the LEVEL/SLOPE control set to the negative slope.

Performance: Correct _____ ; Incorrect _____ .

4. Check AUTO Triggering Sensitivity Page 5-5

Requirement: Stable triggering on a 0.3 division 50 kHz signal with the LEVEL/SLOPE control set near 9:00 and 3:00.

Performance: Correct _____ ; Incorrect _____ .

5. Check Normal Triggering Sensitivity Page 5-5

Requirements: Stable triggering on a 0.3 division 50 kHz signal with the LEVEL/SLOPE control set near 9:00 and 3:00.

Performance: Correct _____ ; Incorrect _____ .

6. Adjust DC Level Center (R121) Page 5-6

Requirement: Stable triggering on a 0.3 division 50 kHz signal with LEVEL/SLOPE near 9:00 and COUPLING set to DC.

Performance: Correct _____ ; Incorrect _____ .

7. Check Single Sweep Mode Page 5-6

Requirement: After each sweep, further displays are locked out until the RESET button is pressed.

Performance: Correct _____ ; Incorrect _____ .

8. Adjust External Horizontal Amplifier Balance (R186) Page 5-6

Requirement: With all SOURCE buttons cancelled, adjust for minimum movement of dot as VARIABLE is rotated.
Performance: Correct ____; Incorrect ____.

9. Adjust External Input Balance (R37) Page 5-6

Requirement: Adjusted for no movement of dot as VARIABLE control is rotated.
Performance: Correct ____; Incorrect ____.

10. Adjust External Input Gain (R25) Page 5-6

Requirement: With a one volt signal applied to the EXT TRIG IN connector, the push-pull output of the External Input Amplifier is 0.2 volt.
Performance: Correct ____; Incorrect ____.

11. Check Horizontal Amplifier Gain Page 5-6

Requirement: Display is 4 divisions \pm 0.8 division with a 100 millivolt signal applied to the EXT VOLTS IN connector.
Performance: Correct ____; Incorrect ____.

12. Check Trigger Bandwidth Page 5-7

Requirement: Trigger Bandwidth meets the specifications given in Section 1. Refer to complete procedure.
Performance: Correct ____; Incorrect ____.
list discrepancies _____.

13. Check Sweep Jitter Page 5-8

Requirement: No more than one nanosecond of jitter with a 150 MHz signal applied.
Performance: Correct ____; Incorrect ____.

14. Check Horizontal Amplifier Bandwidth Page 5-8

Requirement: No more than -3 dB at 16 hertz and 100 kilohertz.
Performance: Correct ____; Incorrect ____.

15. Check Amplifier VARIABLE Range Page 5-8

Requirement: With VARIABLE fully clockwise, apply an eight division signal. Turn VARIABLE fully counterclockwise, check for 0.8 division or less display.
Performance: Correct ____; Incorrect ____.

16. Check Line Trigger Source Page 5-9

Requirement: Stable triggering of the proper polarity on the positive and negative slope of the LEVEL/SLOPE control.
Performance: Correct ____; Incorrect ____.

17. Check/Adjust Sweep Calibration (SWP CAL, a front-panel adjust) Page 5-9

Requirement: With 1 ms markers applied and TIME/DIV set to 1 ms, check for one marker each division. The second and tenth markers must line up with their respective graticule lines.
Performance: Correct ____; Incorrect ____.

18. Check/Adjust Magnified Sweep Gain (R785) Page 5-10

Requirement: With TIME/DIV at 1 ms, MAGNIFIER at X10 and .1 ms markers applied, check for one marker each division.
Performance: Correct ____; Incorrect ____.

19. Check/Adjust Magnifier Registration (R795) Page 5-10

Requirement: 0.2 division or less trace shift when switching MAGNIFIER from X10 to X1.
Performance: Correct ____; Incorrect ____.

20. Check Sweep Length Page 5-10

Requirement: Sweep length must be between 10.5 and 13 divisions.
Performance: Correct ____; Incorrect ____.

21. Check Variable Time/Div Page 5-11

Requirement: Continuously variable between calibrated settings of the TIME/DIV switch.
Performance: Correct ____; Incorrect ____.

Performance Check/Calibration—7B70 (SN B205000 and Up)

22. Check/Adjust 5 μs Timing (C530J) Page 5-11

Requirement: With 5 μs markers applied and TIME/DIV set to 5 μs, check for one marker each division. The second and tenth markers must line up with their respective graticule lines.

Performance: Correct ____ ; Incorrect ____ .

23. Check/Adjust .2 μs Timing (C530L) Page 5-12

Requirement: With .1 μs markers applied and TIME/DIV set to .2 μs, check for two markers each division.

Performance: Correct ____ ; Incorrect ____ .

24. Adjust Sweep Start Linearity (C537) Page 5-12

Factory Adjustment, see Note on Page 5-12.

25. Check Sweep Timing Accuracy Page 5-13

Requirement: Accuracy over the center eight divisions is within 3% from 5 seconds/division to 1 second/division; 2% from 0.5 second/division to 0.02 microsecond/division.

Performance: Correct ____ ; Incorrect ____ list discrepancies _____ .

26. Check Magnified Sweep Timing Page 5-13

Requirement: Magnified timing accuracy over the center eight division is within 3.5% from 5 seconds/division to 1 second/division; 2.5% from .5 second/division to 0.02 microsecond/division.

Performance: Correct ____ ; Incorrect ____ .

27. Check Sweep Holdoff Time Page 5-14

Requirement: Holdoff time is 1.5 times the TIME/DIV setting or less for 5 s/Div to 5 μs/Div; 3.5 μs or less for 2 μs/Div to 0.02 μs/Div.

Performance: Correct ____ ; Incorrect ____ .

PERFORMANCE CHECK/CALIBRATION PROCEDURE

The following procedure is arranged so the 7B70 can be calibrated with the least interaction of adjustments and reconnection of equipment. The control settings continue from the preceding step(s) unless noted otherwise.

The following procedure uses the equipment listed under Test Equipment Required. If other equipment is substituted, control settings or calibration setup may need to be altered to meet the requirements of the equipment used. Detailed operating instructions for the test equipment are not given in this procedure. Refer to the instruction manual for the test equipment if more information is required.

NOTE

This instrument should be calibrated at an ambient temperature of +25°C ±10°C for best overall accuracy. If the temperature is outside the given range, see Section 1 for the applicable tolerances.

Preliminary Control Settings

7B70 (B Horizontal Plug-In Compartment)

LEVEL/SLOPE	Centered on Positive Slope (9:00 o'clock)
TRIGGERING MODE	P-P AUTO
COUPLING	AC
SOURCE	INT
POSITION	Midrange
MAGNIFIER	X1
DISPLAY MODE	TIME BASE
TIME/DIV	20 μs
VARIABLE TIME/DIV	CAL IN
AMPLIFIER VARIABLE	Fully Clockwise

7A16A (Left Vertical Plug-In Compartment)

Position	Midrange
Polarity	+ UP
Bandwidth	Full
Volts/Div	.5 V
Coupling	AC

**7B71 (Test Time Base)
(Used only in step 27)**

Oscilloscope

A Intensity	CCW
B Intensity	CCW (see following paragraph)
Vertical Mode	Left
Horizontal Mode	B
A Trigger Source	Vert Mode
B Trigger Source	Vert Mode

Turn the Oscilloscope power on and advance the B Intensity until a free-running trace is observed. Center the trace with the horizontal and vertical Position controls. Allow several minutes warmup before proceeding with calibration.

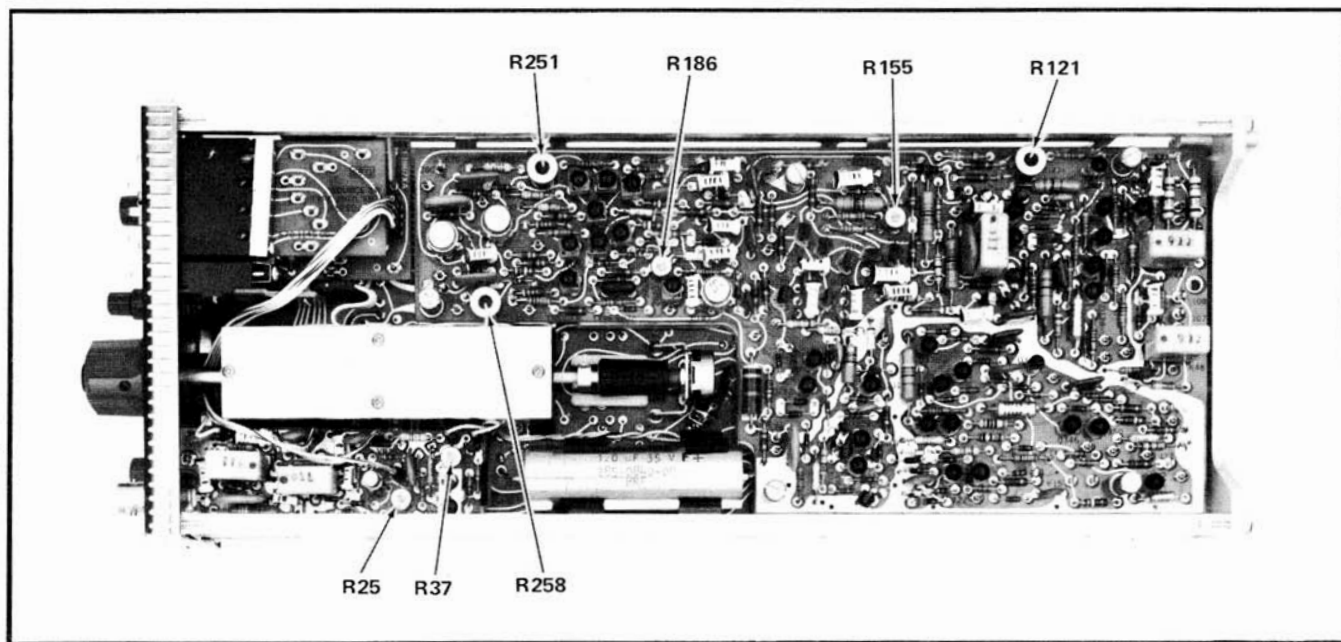

Fig. 5-1. Location of adjustments on Trigger Board.

1. Adjust Upper Positive Slope P-P AUTO Level (R251) ❶

a. Install the 7B70 through the rigid extender in the B Horizontal Plug-In Compartment.

b. Apply 0.5 division of 50 kHz sine wave from the Type 191 sine-wave generator to the 7A16A Input connector. Set the LEVEL/SLOPE control to 11:30 (near the top on the positive slope).

c. ADJUST—R251 for a stable display. See Fig. 5-1 for location of adjustment.

2. Adjust Lower Positive Slope P-P AUTO Level (R258) ❷

a. Reset the LEVEL/SLOPE control to 6:30 (near the bottom on the positive slope).

b. ADJUST—R258 for a stable display. Refer to Fig. 5-1 for location of adjustment.

3. Adjust Negative Slope P-P AUTO Level (R155) ❸

a. Reset the LEVEL/SLOPE control to 3:00 (centered on the negative slope).

b. ADJUST—R155 for a stable display. Refer to Fig. 5-1 for location of adjustment. Check for stable triggering over the full 360° range of the LEVEL/SLOPE control.

4. Check AUTO Triggering Sensitivity

a. Set the TRIGGERING MODE to AUTO. Adjust the Type 191 amplitude for a 0.3 division CRT display.

b. CHECK—For stable triggering with the LEVEL/SLOPE control near 3:00 and near 9:00. Check for a free-running sweep at all other positions.

5. Check NORMAL Triggering Sensitivity

a. Set the TRIGGERING MODE to NORM.

b. CHECK—For stable triggering near 9:00 and near 3:00.

NOTE

The 7A16A Position control must be set for zero volts DC between interface pins A20 and B20 of the 7B70 (center conductor of top female BNC jacks on the right and left side of the rigid extender) before performing step 6.

6. Adjust DC Level Center (R121) ①

a. Set the LEVEL/SLOPE control near 9:00 and adjust for a stable display.

b. ADJUST—Change the TRIGGERING COUPLING to DC and adjust R121 for a stable display. Return the TRIGGERING COUPLING to AC.

7. Check SINGLE SWEEP MODE

a. Adjust the LEVEL/SLOPE control for a stable display and change the TRIGGERING MODE to SINGLE SWEEP.

b. CHECK—Remove the signal from the 7A16A. Press the RESET button and check that the READY light is lit. Reconnect the signal to the 7A16A and check that the sweep runs one time. (Increase the B Intensity as necessary to view the trace.) At the end of the sweep, the ready light should go out. Reduce the B Intensity to its level before step 7.

c. Disconnect the signal from the Type 191.

8. Adjust External Horizontal Amplifier Balance (R186) ①

a. Set the COUPLING to DC and the DISPLAY MODE to AMPLIFIER. Set the SOURCE switch so that all buttons are out (this may be accomplished by pressing lightly on one of the buttons until all the buttons are cancelled).

b. ADJUST—R186 to bring the dot on to the display area. While rotating the AMPLIFIER VARIABLE control, adjust R186 for minimum movement of the dot as the VARIABLE control is rotated throughout its range.

9. Adjust External Input Amplifier Balance (R37) ①

a. Set the SOURCE to EXT.

b. ADJUST—While rotating the AMPLIFIER VARIABLE control throughout its range, adjust R37 for minimum movement of the dot.

10. Adjust External Input Gain (R25) ①

NOTE

Step 10 requires two 7A16A amplifiers or a dual trace amplifier such as the 7A12.

a. Set the TRIGGERING MODE to P-P AUTO, DISPLAY MODE to TIME BASE and apply a one volt signal from the standard amplitude calibrator to the EXT TRIG IN connector. Set the 7B70 TIME/DIV to .2 ms.

b. Set the Oscilloscope Vertical Mode to Add. Set both 7A16A Volts/Div to 50 millivolts. Set the Polarity switch of the 7A16A in the right vertical compartment to Invert. Connect a 1X probe from the left vertical plug-in to pin F on the External Input board and a 1X probe from the right vertical plug-in to pin H on the External Input board. See Fig. 5-2 for location of pins.

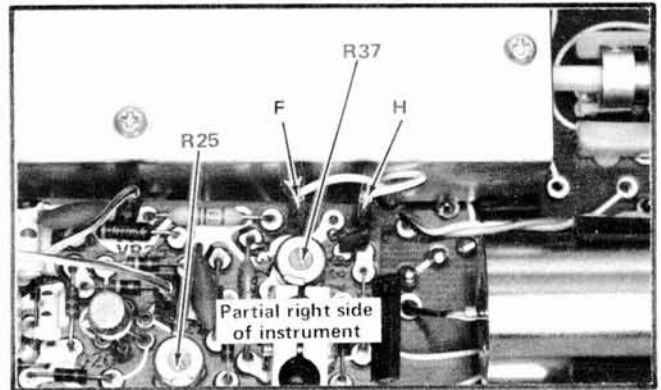

Fig. 5-2. Location of pins for Calibration Step 10.

c. ADJUST—R25 for a four division display on the CRT.

11. Check Horizontal Amplifier Gain

a. Reset the DISPLAY MODE to AMPLIFIER and turn the amplifier VARIABLE control fully clockwise. Apply a 0.1 volt signal from the standard amplitude calibrator to the EXT VOLTS IN connector.

b. CHECK—Display amplitude should be between 3.2 divisions and 4.8 divisions.

c. Reset the SOURCE switch to EXT $\div 10$ and the standard amplitude calibrator to 1 volt.

d. CHECK—Display amplitude should be between 3.2 divisions and 4.8 divisions.

Partial Procedure

If beginning a partial procedure with this step, set the controls as given under Preliminary Control Settings except as follows:

TIME/DIV 10 ms

12. Check Trigger Bandwidth

a. In the following portions of this step, adjust the 7B70 TIME/DIV and LEVEL/SLOPE as necessary to provide 2 or 3 cycles of triggered waveform.

b. Set the controls as given under Preliminary control settings except as follows:

7B70 TIME/DIV 10 ms

c. Connect a 200 Hz sine wave from the low-frequency sine-wave generator through a "T" connector and coaxial cable to the 7A16A input and from the other side of the "T" connector through a coaxial cable and a 2X attenuator to the EXT TRIG IN connector. Adjust the sine-wave generator for a 0.5 division display on the CRT.

d. CHECK—Using the control settings in Table 5-1, check for stable triggering and a lit TRIG'D lamp for each condition listed. Use the TIME/DIV control as necessary for optimum viewing of display.

TABLE 5-1

7B70		Sine-Wave Generator	
COUPLING	SOURCE	Frequency	Amplitude
AC	INT	200 Hz	0.5 div
AC HF REJ	INT	200 Hz	0.5 div
DC	INT	200 Hz	0.5 div
AC LF REJ	INT	30 kHz	0.5 div
AC HF REJ	INT	50 kHz	0.5 div
AC	EXT	200 Hz	125 mV
AC HF REJ	EXT	200 Hz	125 mV
DC	EXT	200 Hz	125 mV
AC LF REJ	EXT	30 kHz	125 mV
AC HF REJ	EXT	50 kHz	125 mV

e. Change the "T" connector from the low-frequency generator to the Type 191 signal output connector (using a GR to BNC adapter). Set the Type 191 frequency to 20 MHz and adjust the amplitude for 125 millivolts.

f. CHECK—Using the control settings in Table 5-2, check for stable triggering and a lit TRIG'D lamp for each condition listed (see step 12a).

TABLE 5-2

7B70		Type 191	
COUPLING	SOURCE	Frequency	Amplitude
DC	EXT	20 MHz	125 mV
AC	EXT	20 MHz	125 mV
AC LF REJ	EXT	20 MHz	125 mV
DC	INT	20 MHz	0.5 div
AC	INT	20 MHz	0.5 div
AC LF REJ	INT	20 MHz	0.5 div

g. Change the "T" connector from the Type 191 signal generator to the 067-0532-01 Calibration Fixture output connector. Set the Calibration Fixture frequency to 200 MHz and adjust the amplitude for a 1.5 division display.

h. CHECK—Using the control settings in Table 5-3, check for stable triggering and a lit TRIG'D lamp for each condition listed.

TABLE 5-3

7B70		Calibration Fixture	
COUPLING	SOURCE	Frequency	Amplitude
AC	INT	200 MHz	1.5 div
DC	INT	200 MHz	1.5 div
AC LF REJ	INT	200 MHz	1.5 div
AC	EXT	200 MHz	375 mV
DC	EXT	200 MHz	375 mV
AC LF REJ	EXT	200 MHz	375 mV

i. Change the "T" connector from the 067-0532-01 calibration fixture to the low frequency sine-wave generator output connector. Adjust the sine-wave generator for a 0.3 division display of a 30 Hz signal. Reset the TRIGGERING MODE to NORM.

Performance Check/Calibration—7B70 (SN B205000 and Up)

j. CHECK—Using the control settings in Table 5-4, check for stable triggering and a lit TRIG'D lamp for each condition listed (see step 12a).

TABLE 5-4

7B70		Sine-Wave Generator	
COUPLING	SOURCE	Frequency	Amplitude
AC	INT	30 Hz	0.3 div
AC HF REJ	INT	30 Hz	0.3 div
DC	INT	30 Hz	0.3 div
AC LF REJ	INT	30 kHz	0.3 div
AC HF REJ	INT	50 kHz	0.3 div
AC	EXT	30 Hz	75 mV
AC HF REJ	EXT	30 Hz	75 mV
DC	EXT	30 Hz	75 mV
AC LF REJ	EXT	30 kHz	75 mV
AC HF REJ	EXT	50 kHz	75 mV

k. Set the 7B70 COUPLING to DC and change the "T" connector from the low-frequency generator to the Type 191 signal generator output connector (using a GR to BNC adapter). Set the Type 191 frequency to 20 MHz and adjust the amplitude for 75 millivolts.

l. CHECK—Using the control settings in Table 5-5, check for stable triggering and a lit TRIG'D lamp for each condition listed (see step 12a).

TABLE 5-5

7B70		Type 191	
COUPLING	SOURCE	Frequency	Amplitude
DC	EXT	20 MHz	75 mV
AC	EXT	20 MHz	75 mV
AC LF REJ	EXT	20 MHz	75 mV
DC	INT	20 MHz	0.3 div
AC	INT	20 MHz	0.3 div
AC LF REJ	INT	20 MHz	0.3 div

m. Set the 7B70 COUPLING to AC, SOURCE to INT, and change the "T" connector from the Type 191 signal generator to the 067-0532-01 Calibration Fixture output connector. Set the Calibration Fixture frequency to 200 MHz and adjust the amplitude for a 1.5 division display.

n. CHECK—Using the control settings in Table 5-6, check for stable triggering and a lit TRIG'D lamp for each condition listed (see step 12a).

TABLE 5-6

7B70		Calibration Fixture	
COUPLING	SOURCE	Frequency	Amplitude
AC	INT	200 MHz	1.5 div
DC	INT	200 MHz	1.5 div
AC LF REJ	INT	200 MHz	1.5 div
AC	EXT	200 MHz	375 mV
DC	EXT	200 MHz	375 mV
AC LF REJ	EXT	200 MHz	375 mV

13. Check Sweep Jitter

a. Set the 7B70 TIME/DIV to .02 microsecond, MAGNIFIER to X10, and SOURCE to INT.

b. Set the 067-0532-01 Calibration Fixture to 150 MHz and adjust the amplitude for a four division display.

c. CHECK—For no more than 0.5 division (1 nanosecond) of jitter. Disregard any slow drift.

d. Disconnect the Calibration Fixture, "T" connector, and attenuator.

14. Check Horizontal Amplifier Bandwidth

a. Reset the SOURCE to EXT, COUPLING to AC, and DISPLAY MODE to AMPLIFIER. Connect a 1 kHz signal from the low-frequency sine-wave generator through a 50 Ω BNC cable to the EXT VOLTS IN connector, and adjust the sine-wave generator amplitude for six horizontal divisions of display on the CRT (use the Position control as necessary).

b. CHECK—Reset the sine-wave generator to 100 kHz and check for a display amplitude of at least 4.2 divisions.

15. Check Amplifier VARIABLE Range

a. Adjust the sine-wave generator for an eight division horizontal display on the CRT. (The VARIABLE control must be set fully clockwise.)

b. CHECK—Rotate the VARIABLE control fully counterclockwise and check for 0.8 division or less of horizontal display.

c. Return the VARIABLE control to its fully clockwise position. Disconnect the low-frequency sine-wave generator.

16. Check Line Trigger Source

a. Change the control settings as follows:

7B70	
DISPLAY MODE	TIME BASE
TIME/DIV	5 ms
TRIGGERING	
MODE	NORM
COUPLING	AC
SOURCE	LINE
MAGNIFIER	X1

7A16A	
Volts/Div	1 V
Coupling	AC

b. Connect a probe from the 7A16A Input to interface connector A4 (plug-in connector at the rear of the 7B70). See Fig. 5-3.

c. CHECK—For stable triggering of the proper polarity with the LEVEL/SLOPE control set to the positive slope and to the negative slope.

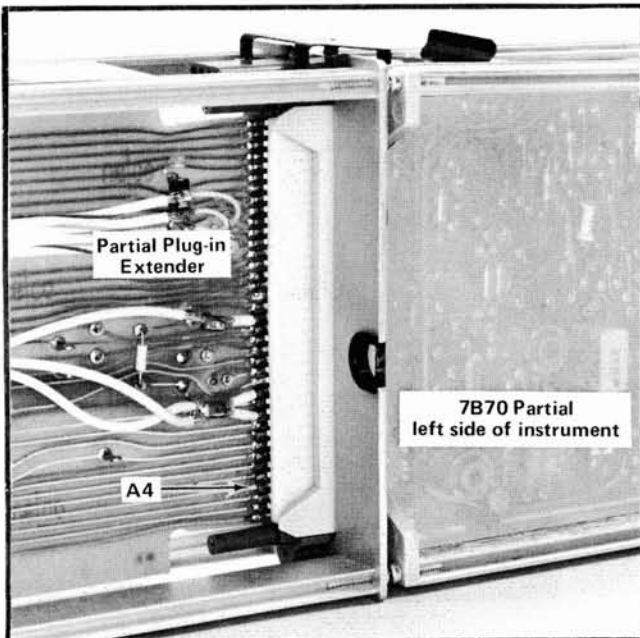

Fig. 5-3. Location of interface connector A4.

Partial Procedure

If beginning a partial procedure with this step, set the controls as given under Preliminary Control Settings except as follows:

	7A16A	
VOLTS/DIV		2 V
	7B70	
TIME/DIV		1 ms

17. Check/Adjust Sweep Calibration (SWP CAL, a front-panel adjustment)

a. Set the VOLTS/DIV to 2 V.

b. Set the TIME/DIV to 1 ms, SOURCE to INT, and TRIGGERING MODE to P-P AUTO.

c. Apply 1 ms markers from the 2901 Time-Mark Generator through a 50 Ω cable and 50 Ω termination at the 7A16A input.

d. CHECK—CRT display for one 1 ms marker for each division between the second and tenth vertical lines (see Fig. 5-4).

NOTE

Unless otherwise noted, use the center eight horizontal divisions when checking or adjusting timing.

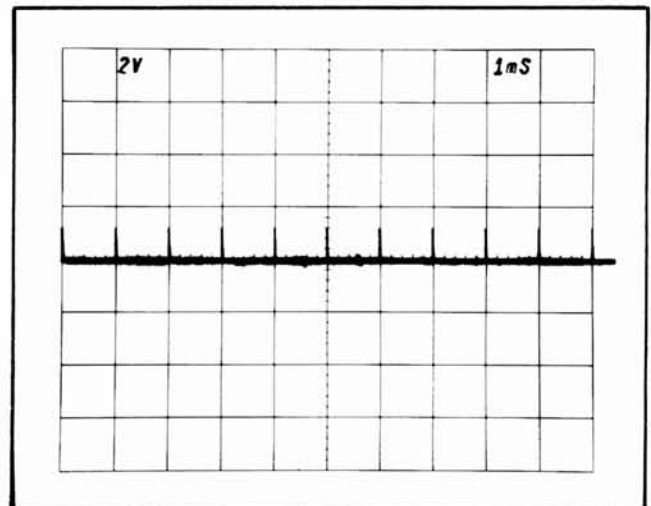

Fig. 5-4. CRT display showing SWP CAL adjustment correctly set.

Performance Check/Calibration—7B70 (SN B205000 and Up)

PERFORMANCE CHECK ONLY

Front-panel adjustment; can be adjusted as part of the performance check.

e. ADJUST—SWP CAL, a front-panel adjust, for one marker for each division. The second and tenth markers must line up with their respective graticule lines (use the horizontal POSITION control as necessary to line up the display).

f. CHECK—The timing accuracy is within 5% over any two division interval within the center eight divisions.

g. INTERACTION: Check Steps 18 through 25.

18. Check/Adjust Magnified Sweep Gain (R785) ❶

- a. Set the time-mark generator for .1 ms markers.
- b. Set the MAGNIFIER to X10.
- c. CHECK—CRT display for one .1 ms marker for each division between the second and tenth vertical lines.
- d. ADJUST—R785 (left side toward rear), Magnifier Gain, for one marker for each division. The second and tenth markers must coincide exactly with their respective graticule lines (use the horizontal POSITION control as necessary to line up the display).
- e. CHECK—Timing accuracy is within 5% over any two division interval within the center eight divisions.
- f. INTERACTION: Check steps 19 and 25.

19. Check/Adjust Magnifier Registration (R795) ❷

- a. Set the time-mark generator for 5 ms markers. Set the 7A16 Volts/Div to 1 V.
- b. Position the middle marker to the center vertical line (there are three markers on the total magnified sweep) with the horizontal POSITION control. See Fig. 5-5A.

c. CHECK—Set the MAGNIFIER to X1 and check that the middle marker remains at the center vertical line. See Fig. 5-5B.

d. ADJUST—Mag Regis, R795 (left side, lower rear), to position the middle marker to the center vertical line.

e. Set the 7B70 MODE to NORM and alternately switch the MAGNIFIER between X1 and X10 and repeat steps b through e until no shift occurs when switching.

20. Check Sweep Length

a. Set the Time-Mark Generator for 1 ms and .1 ms markers. Reset the MAGNIFIER to X1 and the 7A16A Volts/Div to 2 V (adjust LEVEL/SLOPE as necessary for stable triggering).

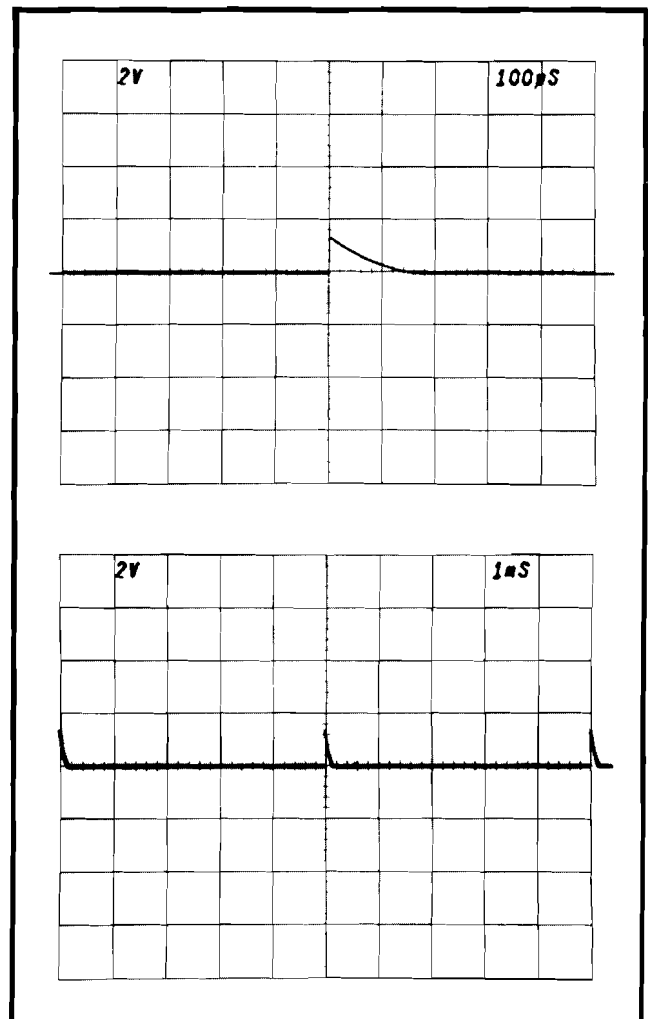

Fig. 5-5. CRT display showing correct magnifier registration. (A) MAGNIFIER set to X10 and (B) MAGNIFIER set to X1.

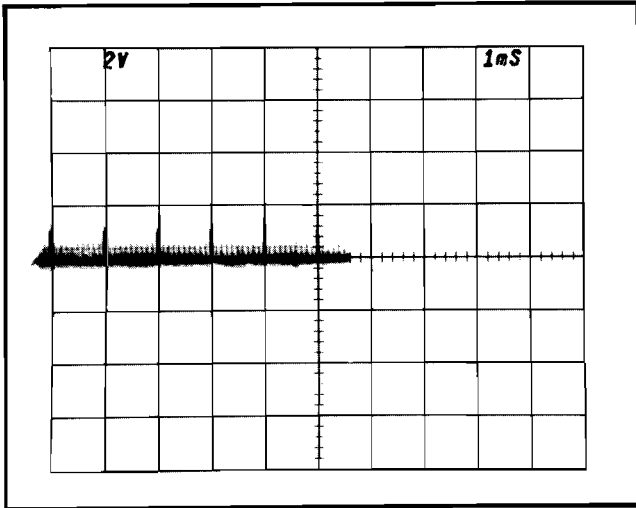

Fig. 5-6. CRT display when checking sweep length.

b. Move the eleventh 1 ms marker to the center vertical line with the horizontal POSITION control. See Fig. 5-6.

c. CHECK—Sweep length must be between 10.5 and 13 divisions.

21. Check Variable Time/Div

a. Reset the TIME/DIV to 2 ms. Set the time-mark generator for 10 ms markers.

b. Press and release the VARIABLE TIME/DIV knob and turn fully counterclockwise.

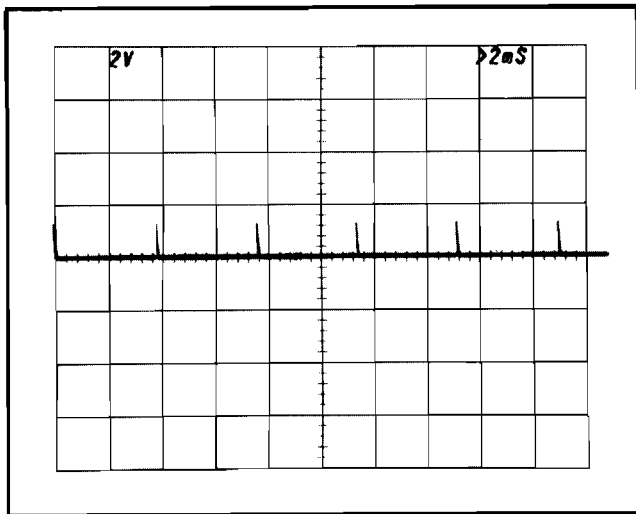

Fig. 5-7. Typical CRT display when checking VARIABLE control range.

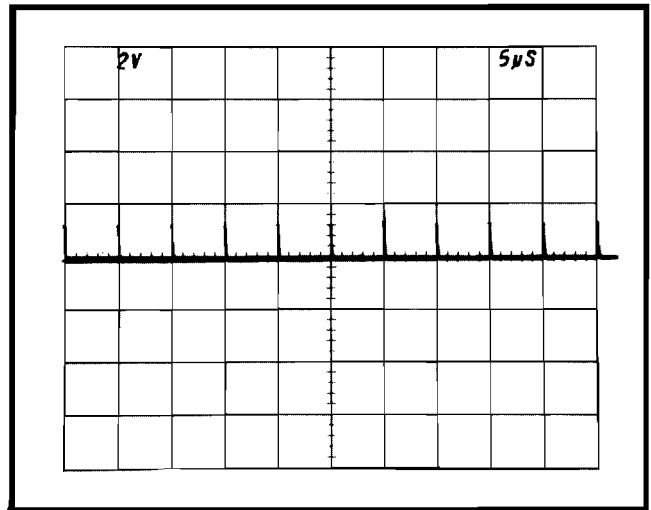

Fig. 5-8. CRT display showing correct 5 μ s timing.

c. CHECK—CRT display for a two-division maximum spacing between markers (indicates adequate range for continuously variable sweep rate between the calibrated steps; see Fig. 5-7). Return the VARIABLE TIME/DIV to the CAL IN position.

NOTE

For the following steps, the 7B70 must be installed inside the oscilloscope (not on the extender). If the optional flexible plug-in extender is available, the 7A16A may be connected through it to provide easier access to adjustments on the left side of the 7B70.

22. Check/Adjust 5 μ s Timing (C530J) ❶

a. Set the Time-Mark Generator for 5 μ s markers.

b. Reset the TIME/DIV to 5 μ s and adjust the LEVEL/SLOPE control for a stable display.

c. CHECK—CRT display for one marker each division between the second and tenth vertical lines. Check that sweep timing is within 0.16 division (2%) over the center eight divisions. See Fig. 5-8.

d. ADJUST—C530J (left side, front below center) for one marker each division. The second and tenth markers must coincide exactly with their respective graticule lines.

23. Check/Adjust .2 μs Timing (C530L) ⓘ

- a. Set the time-mark generator for .1 μs markers.
- b., Set the TIME/DIV to .2 μs.
- c. CHECK—CRT display for two markers each division over the center eight divisions. Check that sweep timing is within 0.16 division (2%) over center eight divisions. See Fig. 5-9.
- d. ADJUST—C530L (left side, lower front) for two markers each division. The markers at the second and tenth vertical lines must coincide exactly with their respective graticule lines (use the horizontal POSITION control as necessary to line up the display).

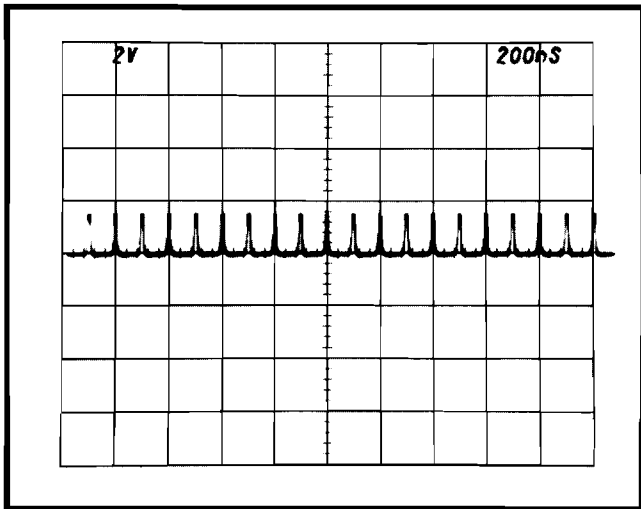

Fig. 5-9. CRT display showing correct 0.2 μs timing.

24. ADJUST—Sweep Start Linearity (C537) ⓘ

Refer to following Note before attempting adjustment of C537.

NOTE

C537 is a factory adjustment and normally should not require readjustment unless: 1. C537 is replaced

because of breakage or other defect. 2. Associated major components replaced. 3. C537 has accidentally been mis-adjusted. Gross misadjustment of C537 can result in waveform instability and sweep foldover near the start of the sweep. C537 adjustment is effective only with higher performance main-frames such as the 7900-series, and may be adjusted to optimize the performance of the plug-in and main-frame as a package. This adjustment should be made with the 7B70 installed in the highest performance main-frame it will be used with. C537 primarily affects the first two screen diameters following the excluded first 12 ns of sweep at the highest magnified sweep speed.

- a. Set the controls as specified under Preliminary Control Settings except as follows:

Time-Mark Generator

- Markers 5 ns
- 7B70**
(Installed in right (B) horizontal compartment not on extender)
- T/DIV .02 μs
- POSITION Start of sweep near first graticule line
- MAGNIFIER X10

7B71
Removed from the Oscilloscope

7A16A

- Volts/Div Adjust for about 3 divisions display amplitude

Oscilloscope

- B Intensity Adjust for visible display
- Vertical Mode Left
- Horizontal Mode B

- b. ADJUST—C537 (bottom left side forward of center) for best linearity of the 12 ns to 52 ns portion of the sweep start. Position the first (excluded) 12 ns portion of the sweep off screen to the left. Adjust C537 for best overall linearity of the next 40 ns portion of the sweep.

25. Check Sweep Timing Accuracy

a. Set MAGNIFIER to X1. Using the control settings given in Table 5-7, check that sweep timing accuracy over the center eight divisions of the display is within the allowable limits.

TABLE 5-7

7B70 TIME/DIV	2901 Markers	Markers/Div	Allowable Error
0.02 μ s	20 ns	1	± 0.16 div
.05 μ s	50 ns	1	
.1 μ s	.1 μ s	1	
.2 μ s	.1 μ s	2	
.5 μ s	.5 μ s	1	
1 μ s	1 μ s	1	
2 μ s	1 μ s	2	
5 μ s	5 μ s	1	
10 μ s	10 μ s	1	
20 μ s	10 μ s	2	
50 μ s	50 μ s	1	
.1 ms	.1 ms	1	
.2 ms	.1 ms	2	
.5 ms	.5 ms	1	
1 ms	1 ms	1	
2 ms	1 ms	2	
5 ms	5 ms	1	
10 ms	10 ms	1	
20 ms	10 ms	2	
50 ms	50 ms	1	
.1 s	.1 s	1	± 0.24 div
.2 s	.1 s	2	
.5 s	.5 s	1	
1 s	1 s	1	
2 s	1 s	2	
5 s	5 s	1	

over the center eight divisions. Adjust Volts/Div, B Intensity, and triggering for a stable display.

TABLE 5-8

7B70 TIME/DIV	2901 Markers	Markers/Div	Allowable Error	
.02 μ s	10 ns	1 cycle/5 div	0.13 div/5 div	
.05 μ s	5 ns	1		
.1 μ s	10 ns	1		
.2 μ s	20 ns	1		
.5 μ s	50 ns	1		
1 μ s	.1 μ s	1		
2 μ s	.1 μ s	2		
5 μ s	.5 μ s	1		
10 μ s	1 μ s	1		
20 μ s	1 μ s	2		
50 μ s	5 μ s	1		
.1 ms	10 μ s	1		± 0.2 div
.2 ms	10 μ s	2		
.5 ms	50 μ s	1		
1 ms	.1 ms	1		
2 ms	.1 ms	2		
5 ms	.5 ms	1		
10 ms	1 ms	1		
20 ms	1 ms	2		
50 ms	5 ms	1		
.1 s	10 ms	1	± 0.28 div	
.2 s	10 ms	2		
.5 s	50 ms	1		
1 s	.1 s	1		
2 s	.1 s	2		
5 s	.5 s	1		

26. Check Magnified Sweep Timing

a. CHECK—With the MAGNIFIER set to X10, use the control settings given in Table 5-8 to check timing accuracy

b. Reset the MAGNIFIER to X1. Disconnect the time-mark generator.

27. Check Sweep Holdoff Time

a. Install the 7B70 (on the rigid extender to allow probe access to TP566) in the B Horizontal Plug-In Compartment. Change the control settings as follows:

7A16A
 Volts/Div .2 V

7B70
 TRIGGERING MODE P-P AUTO
 COUPLING AC
 SOURCE INT
 DISPLAY MODE TIME BASE
 TIME/DIV .02 μ s
 MAGNIFIER X1

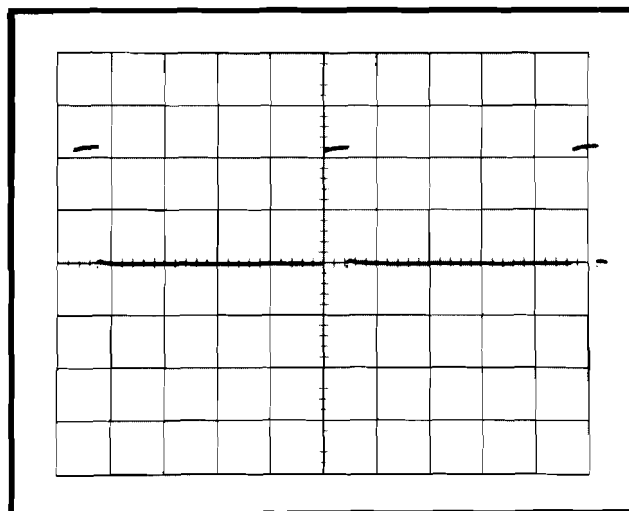

Fig. 5-10. CRT display when checking sweep holdoff time.

TABLE 5-9

7B70 TIME/DIV	7B71 TIME/DIV	HOLDOFF (Equal or less than)
.02 μ s	.5 μ s	3.5 μ s
.05 μ s	.5 μ s	3.5 μ s
.1 μ s	1 μ s	3.5 μ s
.2 μ s	1 μ s	3.5 μ s
.5 μ s	5 μ s	3.5 μ s
1 μ s	5 μ s	3.5 μ s
2 μ s	5 μ s	3.5 μ s
5 μ s	10 μ s	7.5 μ s
10 μ s	20 μ s	15 μ s
20 μ s	50 μ s	30 μ s
50 μ s	.1 ms	75 μ s
.1 ms	.2 ms	.15 ms
.2 ms	.5 ms	.3 ms
.5 ms	1 ms	.75 ms
1 ms	2 ms	1.5 ms
2 ms	5 ms	3 ms
5 ms	10 ms	7.5 ms
10 ms	20 ms	15 ms
20 ms	50 ms	30 ms
50 ms	.1 s	75 ms
.1 s	.2 s	.15 s
.2 s	.2 s	.15 s
.5 s	.2 s	.15 s
1 s	.2 s	.15 s
2 s	.2 s	.15 s
5 s	.2 s	.15 s

Test Time Base²
 (Installed in the A Horizontal Plug-In Compartment)

Level/Slope Centered on Positive Slope

Triggering Mode Norm
 Coupling AC
 Source Int
 B Delay Mode Independent
 Magnifier X1
 Time/Div .5 μ s
 Position Midrange
 Variable Time/Div Cal In

Oscilloscope

Vertical Mode Left
 Horizontal Mode A
 A Trigger Source Left Vert
 B Trigger Source Right Vert
 A Intensity Adjust for viewable trace

b. Connect a 10X probe from the 7A16A to TP566 (near R785, left side, lower rear) on the 7B70 Time Base board.

c. CHECK—The holdoff time (see Fig. 5-10) corresponds to the values given in Table 5-9.

²If a test time base other than the 7B71 is used, refer to the instruction manual for the time base being used for appropriate control settings.

This completes the calibration of the 7B70 Time Base.

REPLACEABLE ELECTRICAL PARTS

PARTS ORDERING INFORMATION

Replacement parts are available from or through your local Tektronix, Inc. Field Office or representative.

Changes to Tektronix instruments are sometimes made to accommodate improved components as they become available, and to give you the benefit of the latest circuit improvements developed in our engineering department. It is therefore important, when ordering parts, to include the following information in your order: Part number, instrument type or number, serial number, and modification number if applicable.

If a part you have ordered has been replaced with a new or improved part, your local Tektronix, Inc. Field Office or representative will contact you concerning any change in part number.

Change information, if any, is located at the rear of this manual.

SPECIAL NOTES AND SYMBOLS

X000 Part first added at this serial number
00X Part removed after this serial number

ITEM NAME

In the Parts List, an Item Name is separated from the description by a colon (:). Because of space limitations, an Item Name may sometimes appear as incomplete. For further Item Name identification, the U.S. Federal Cataloging Handbook H6-1 can be utilized where possible.

ABBREVIATIONS

ACTR	ACTUATOR	PLSTC	PLASTIC
ASSY	ASSEMBLY	QTZ	QUARTZ
CAP	CAPACITOR	RECP	RECEPTACLE
CER	CERAMIC	RES	RESISTOR
CKT	CIRCUIT	RF	RADIO FREQUENCY
COMP	COMPOSITION	SEL	SELECTED
CONN	CONNECTOR	SEMICOND	SEMICONDUCTOR
ELCTLT	ELECTROLYTIC	SENS	SENSITIVE
ELEC	ELECTRICAL	VAR	VARIABLE
INCAND	INCANDESCENT	WW	WIREWOUND
LED	LIGHT EMITTING DIODE	XFMR	TRANSFORMER
NONWIR	NON WIREWOUND	XTAL	CRYSTAL

CROSS INDEX MFR. CODE NUMBER TO MANUFACTURER

MFR.CODE	MANUFACTURER	ADDRESS	CITY,STATE,ZIP
00853	Sangamo Electric Co., S. Carolina Div.	P. O. Box 128	Pickens, SC 29671
01121	Allen-Bradley Co.	1201 2nd St. South	Milwaukee, WI 53204
01295	Texas Instruments, Inc., Semiconductor Group	P. O. Box 5012	Dallas, TX 75222
03508	General Electric Co., Semi-Conductor Products Dept.	Electronics Park	Syracuse, NY 13201
04713	Motorola, Inc., Semiconductor Products Div.	5005 E. McDowell Rd.	Phoenix, AZ 85036
07263	Fairchild Semiconductor, A Div. of Fairchild Camera and Instrument Corp.	464 Ellis St.	Mountain View, CA 94042
07910	Teledyne Semiconductor	12515 Chadron Ave.	Hawthorne, CA 90250
08806	General Electric Co., Miniature Lamp Products Dept.	Nela Pk.	Cleveland, OH 44112
11237	CTS Keene, Inc.	Commerce Drive	Paso Robles, CA 93446
12040	National Semiconductor Corp.	Lower Washington St.	Danbury, CT 06810
12697	Clarostat Mfg. Co., Inc.		Dover, NH 03820
13715	Fairchild Semiconductor, A Div. of Fairchild Camera and Instrument Corp.	4300 Redwood Hwy.	San Rafael, CA 94903
14936	General Instrument Corp., Semiconductor Products Group	600 W. John St. 1300 Terra Bella Ave.	Hicksville, NY 11802 Mountain View, CA 94040
15818	Teledyne Semiconductor	1177 Blue Heron Blvd.	Riviera Beach, FL 33404
21845	Solitron Devices, Inc., Transistor Div.	3560 Madison Ave.	Indianapolis, IN 46227
24931	Specialty Connector Co., Inc.	1501 Page Mill Rd.	Palo Alto, CA 94304
28480	Hewlett-Packard Co., Corporate Hq.	2201 E. Elvira Road	Tucson, AZ 85706
32159	West-Cap Arizona		North Adams, MA 01247
56289	Sprague Electric Co.		
71590	Centralab Electronics, Div. of Globe-Union, Inc.	5757 N. Green Bay Ave. 644 W. 12th St.	Milwaukee, WI 53201 Erie, PA 16512
72982	Erie Technological Products, Inc.	2500 Harbor Blvd.	Fullerton, CA 92634
73138	Beckman Instruments, Inc., Helipot Div.		
75042	TRW Electronic Components, IRC Fixed Resistors, Philadelphia Division	401 N. Broad St. P. O. Box 500	Philadelphia, PA 19108 Beaverton, OR 97077
80009	Tektronix, Inc.	6135 Magnolia Ave.	Riverside, CA 92506
80294	Bourns, Inc., Instrument Div.	2500 Harbor Blvd.	Fullerton, CA 92634
80740	Beckman Instruments, Inc.		
90201	Mallory Capacitor Co., Div. of P. R. Mallory Co., Inc.	3029 E. Washington St.	Indianapolis, IN 46206

Electrical Parts List—7B70 (SN B205000-up)

Ckt No.	Tektronix	Serial/Model No.		Name & Description	Mfr	Mfr Part Number
	Part No.	Eff	Dscont		Code	
CHASSIS						
DS347	150-0048-01			LAMP, INCAND:NO.683,SELECTED	08806	683AS15
C530A)	1 295-0165-00			10UF	80009	295-0165-10
C530B)				1UF		
C530E)				CAP.,MATCHED:0.1UF		
C530F)				0.01UF		
C530H)				995PF		
J1	131-0955-00			CONNECTOR,RCPT,:BNC,FEMALE	24931	28JR200-1
R146A)	2 311-0912-00			RES.,VAR, NONWIR:2.5K OHM,10%,1W	01121	W-3083E
R146B)				10K OHM,50%,1W		
R194	311-0091-00			RES.,VAR, NONWIR:1K OHM,10%,0.50W	11237	41336
R740	311-0486-00			RES.,VAR, NONWIR:500 OHM,10%	12697	381-CM39691
R744A)	311-1162-00			RES.,VAR, NONWIR:2 X 10K OHM,10%,1W	12697	381-CM39691
R744B)						
S146	311-0972-00			RES.,VAR, NONWIR:2.5K OHM,10%,1W 10K OHM,50%,1W	80009	311-0972-00
	670-1144-00			CKT BOARD ASSY:EXTERNAL INPUT	80009	670-1144-00
C1	281-0534-00			CAP.,FXD,CER DI:3.3PF,+/-0.25PF,500V	72982	301-000C0J0339C
C2	283-0068-00			CAP.,FXD,CER DI:0.01UF,+100-0%,500V	56289	19C241
C3	283-0080-00			CAP.,FXD,CER DI:0.022UF,+80-20%,25V	56289	19C611
C5	281-0718-00			CAP.,FXD,CER DI:15.8PF,1%,500V	72982	374-005C0G01589F
C6	283-0080-00			CAP.,FXD,CER DI:0.022UF,+80-20%,25V	56289	19C611
C10	281-0632-00			CAP.,FXD,CER DI:35PF,1%,500V	72982	308-000C0G0350F
C12	281-0653-00			CAP.,FXD,CER DI:3.3PF,30%,200V	72982	374-001C0K0109C
C13	281-0534-00			CAP.,FXD,CER DI:3.3PF,+/-0.25PF,500V	72982	301-000C0J0339C
C15	281-0610-00			CAP.,FXD,CER DI:2.2PF,+/-0.1PF,500V	72982	374-001C0J0229B
C31	283-0156-00			CAP.,FXD,CER DI:1000PF,+100-0%,200V	72982	8111A208E102Z
C39	283-0156-00			CAP.,FXD,CER DI:1000PF,+100-0%,200V	72982	8111A208E102Z
C55	283-0080-00			CAP.,FXD,CER DI:0.022UF,+80-20%,25V	56289	19C611
C57	283-0080-00			CAP.,FXD,CER DI:0.022UF,+80-20%,25V	56289	19C611
CR15	152-0246-00			SEMICONV DEVICE:SILICON,400PIV,200MA	07910	CD12676
K3	148-0035-00			RELAY,ARMATURE:SPDT,15VDC,600 OHM	80009	148-0035-00
K6	148-0034-00			RELAY,ARMATURE:DPDT,15VDC,600 OHM	80009	148-0034-00
Q20A,B	151-1009-00			TRANSISTOR:SILICON,FET,N CHANNEL,DUAL		
Q30	151-0221-02			TRANSISTOR:SILICON,PNP		
Q37	151-0221-02			TRANSISTOR:SILICON,PNP		
R1	315-0270-00			RES.,FXD,COMP:27 OHM,5%,0.25W	01121	CB2705
R2	315-0101-00			RES.,FXD,COMP:100 OHM,5%,0.25W	01121	CB1015
R5	323-0452-00			RES.,FXD,FILM:499K OHM,1%,0.50W	75042	CECT0-4993F
R7	321-0452-00			RES.,FXD,FILM:499K OHM,1%,0.125W	75042	CEAT0-4993F
R8	321-0448-00			RES.,FXD,FILM:453K OHM,1%,0.125W	75042	CEAT0-4533F
R10	315-0390-00			RES.,FXD,COMP:39 OHM,5%,0.25W	01121	CB3905
R11	321-0361-00			RES.,FXD,FILM:56.2K OHM,1%,0.125W	75042	CEAT0-5622F

¹Individual timing capacitors in this assembly must be ordered by the 9-digit part number, letter suffix and tolerance printed on the timing capacitor to be replaced. The letter suffix and the tolerance should be the same for all of the timing capacitors in the assembly.

Example: 285-XXXX-XX F-

²Furnished as a unit with S146.

Electrical Parts List—7B70 (SN B205000-up)

Ckt No.	Tektronix Part No.	Serial/Model No. Eff	Dscont	Name & Description	Mfr Code	Mfr Part Number
R12	315-0270-00			RES.,FXD,COMP:27 OHM,5%,0.25W	01121	CB2705
R15	315-0100-00			RES.,FXD,COMP:10 OHM,5%,0.25W	01121	CB1005
R16	315-0270-00			RES.,FXD,COMP:27 OHM,5%,0.25W	01121	CB2705
R20	315-0101-00			RES.,FXD,COMP:100 OHM,5%,0.25W	01121	CB1015
R22	315-0392-00			RES.,FXD,COMP:3.9K OHM,5%,0.25W	01121	CB3925
R23	315-0391-00			RES.,FXD,COMP:390 OHM,5%,0.25W	01121	CB3915
R25	311-0634-00			RES.,VAR,NONWIR:500 OHM,10%,0.50W	80740	62-55-3
R26	315-0392-00			RES.,FXD,COMP:3.9K OHM,5%,0.25W	01121	CB3925
R27	315-0270-00			RES.,FXD,COMP:27 OHM,5%,0.25W	01121	CB2705
R28	315-0101-00			RES.,FXD,COMP:100 OHM,5%,0.25W	01121	CB1015
R31	315-0331-00			RES.,FXD,COMP:330 OHM,5%,0.25W	01121	CB3315
R33	321-0185-00			RES.,FXD,FILM:825 OHM,1%,0.125W	75042	CEATO-8250F
R34	315-0360-00			RES.,FXD,COMP:36 OHM,5%,0.25W	01121	CB3605
R36	321-0174-00			RES.,FXD,FILM:634 OHM,1%,0.125W	75042	CEATO-6340F
R37	311-0634-00			RES.,VAR,NONWIR:500 OHM,10%,0.50W	80740	62-55-3
R39	315-0331-00			RES.,FXD,COMP:330 OHM,5%,0.25W	01121	CB3315
VR25	152-0127-00			SEMICOND DEVICE:ZENER,0.4W,7.5V,5%	04713	1N755A
	670-1136-05			CKT BOARD ASSY:TRIGGER	80009	670-1136-05
C44	283-0080-00			CAP.,FXD,CER DI:0.022UF,+80-20%,25V	56289	19C611
C48	283-0000-00			CAP.,FXD,CER DI:0.001UF,+100-0%,500V	72982	831-516E102P
C100	281-0544-00			CAP.,FXD,CER DI:5.6PF,10%,500V	72982	301-000COH0569D
C104	281-0544-00			CAP.,FXD,CER DI:5.6PF,10%,500V	72982	301-000COH0569D
C106	283-0000-00			CAP.,FXD,CER DI:0.001UF,+100-0%,500V	72982	831-516E102P
C108	283-0000-00			CAP.,FXD,CER DI:0.001UF,+100-0%,500V	72982	831-516E102P
C120	283-0080-00	XB230000		CAP.,FXD,CER DI:0.022UF,+80-20%,25V	56289	19C611
C128	283-0059-00			CAP.,FXD,CER DI:1UF,+80-20%,25V	72982	8141N038651105Z
C129	290-0134-00			CAP.,FXD,ELCTLT:22UF,20%,15V	56289	150D226X0015B2
C136	283-0080-00			CAP.,FXD,CER DI:0.022UF,+80%-20%,25V	56289	19C611
C138	283-0079-00			CAP.,FXD,CER DI:0.01UF,20%,250V	72982	8151B202C103M
C141	281-0593-00			CAP.,FXD,CER DI:3.9PF,10%,500V	72982	301-000C0J0399C
C147	281-0593-00			CAP.,FXD,CER DI:3.9PF,10%,500V	72982	301-000C0J0399C
C150	281-0629-00			CAP.,FXD,CER DI:33PF,5%,600V	72982	308-000COG0330G
C152	281-0543-00			CAP.,FXD,CER DI:270PF,10%,500V	72982	301-055X5P1271K
C156	281-0629-00			CAP.,FXD,CER DI:33PF,5%,600V	72982	308-000COG0330G
C170	281-0534-00			CAP.,FXD,CER DI:3.3PF,+/-0.25PF,500V	72982	301-000C0J0339C
C171	281-0534-00			CAP.,FXD,CER DI:3.3PF,+/-0.25PF,500V	72982	301-000C0J0339C
C173	283-0000-00			CAP.,FXD,CER DI:0.001UF,+100-0%,500V	72982	831-516F102P
C176	281-0552-00			CAP.,FXD,CER DI:25PF,5%,500V	72982	301-000P2G0250J
C178	283-0002-00			CAP.,FXD,CER DI:0.01UF,+80-20%,500V	72982	811-546E103Z
C179	283-0000-00			CAP.,FXD,CER DI:0.001UF,+100-0%,500V	72982	831-516E102P
C181	281-0541-00	XB210000		CAP.,FXD,CER DI:6.8PF,10%,500V	72982	301-000COH0689D
C188	281-0593-00			CAP.,FXD,CER DI:3.9PF,10%,500V	72982	301-000C0J0399C
C198	283-0059-00			CAP.,FXD,CER DI:1UF,+80-20%,25V	72982	8141N038651105Z
C199A,B	283-0059-00			CAP.,FXD,CER DI:1UF,+80-20%,25V	72982	8141N038651105Z
C200	281-0511-00			CAP.,FXD,CER DI:22PF,+/-2.2PF,500V	72982	301-000COG0220K
C201	283-0059-00			CAP.,FXD,CER DI:1UF,+80-20%,25V	72982	8141N038651105Z
C203	281-0511-00			CAP.,FXD,CER DI:22PF,+/-2.2PF,500V	72982	301-000COG0220K
C204	283-0059-00			CAP.,FXD,CER DI:1UF,+80-20%,25V	72982	8141N038651105Z

Electrical Parts List--7B70 (SN B205000-up)

Ckt No.	Tektronix Part No.	Serial/Model No. Eff	Dscont	Name & Description	Mfr Code	Mfr Part Number
C207	283-0080-00			CAP.,FXD,CER DI:0.022UF,+80-20%,25V	56289	19C611
C209	290-0267-00			CAP.,FXD,ELCTLT:1UF,20%,35V	56289	162D105X0035CD2
C210	281-0523-00			CAP.,FXD,CER DI:500PF,+/-20PF,350V	72982	301-000U2M0101M
C212	281-0523-00			CAP.,FXD,CER DI:500PF,+/-20PF,350V	72982	301-000U2M0101M
C248	283-0010-00			CAP.,FXD,CER DI:0.05UF,+100-20%,50V	56289	273C20
C255	283-0010-00			CAP.,FXD,CER DI:0.05UF,+100-20%,50V	56289	273C20
C268	283-0604-00			CAP.,FXD,MICA D:304PF,2%,300V	00853	D153F3040GO
C275	281-0523-00			CAP.,FXD,CER DI:500PF,+/-20PF,350V	72982	301-000U2M0101M
C282	283-0002-00			CAP.,FXD,CER DI:0.01UF,+80-20%,500V	72982	811-546E103Z
C303	283-0159-00			CAP.,FXD,CER DI:18PF,5%,50V	72982	8111A058COG180J
C312	283-0080-00			CAP.,FXD,CER DI:0.022UF,+80-20%,25V	56289	19C611
C315	283-0156-00			CAP.,FXD,CER DI:1000PF,+100-0%,200V	72982	8111A208E102Z
C319	283-0080-00			CAP.,FXD,CER DI:0.022UF,+80-20%,25V	56289	19C611
C320	281-0662-00			CAP.,FXD,CER DI:10PF,+/-0.5PF,500V	72982	301-000H3M0100D
C324	283-0175-00			CAP.,FXD,CER DI:10PF,5%,200V	72982	8101-200COG0100J
C331	283-0000-00			CAP.,FXD,CER DI:0.001UF,+100-0%,500V	72982	831-516E102P
C332	283-0159-00			CAP.,FXD,CER DI:18PF,5%,50V	72982	8111A058COG180J
C336	283-0080-00			CAP.,FXD,CER DI:0.022UF,+80-20%,25V	56289	19C611
C339	290-0305-01			CAP.,FXD,ELCTLT:3UF,10%,150V		
C363	283-0059-00			CAP.,FXD,CER DI:1UF,+80-20%,25V	72982	8141N038651105Z
C403	290-0523-00			CAP.,FXD,ELCTLT:2.2UF,20%,20V	56289	196D225X0025HAL
C405	290-0523-00			CAP.,FXD,ELCTLT:2.2UF,20%,20V	56289	196D225X0025HAL
C406	290-0523-00			CAP.,FXD,ELCTLT:2.2UF,20%,20V	56289	196D225X0025HAL
C409	290-0523-00			CAP.,FXD,ELCTLT:2.2UF,20%,20V	56289	196D225X0025HAL
CR148	152-0153-00			SEMICONV DEVICE:SILICON,15V,50MA	13715	FD7003
CR149	152-0153-00			SEMICONV DEVICE:SILICON,15V,50MA	13715	FD7003
CR181	152-0322-00			SEMICONV DEVICE:SILICON,15V	28480	5082-2672
CR182	152-0322-00			SEMICONV DEVICE:SILICON,15V	28480	5082-2672
CR190	152-0185-00			SEMICONV DEVICE:SILICON,40PIV,150MA	07910	1N4152
CR205	152-0322-00			SEMICONV DEVICE:SILICON,15V	28480	5082-2672
CR210	152-0322-00			SEMICONV DEVICE:SILICON,15V	28480	5082-2672
CR212	152-0322-00			SEMICONV DEVICE:SILICON,15V	28480	5082-2672
CR319	152-0322-00			SEMICONV DEVICE:SILICON,15V	28480	5082-2672
CR320	152-0185-00			SEMICONV DEVICE:SILICON,40PIV,150MA	07910	1N4152
CR331	152-0075-00			SEMICONV DEVICE:GE,25V,40MA	14936	GD238
CR342	152-0185-00			SEMICONV DEVICE:SILICON,40PIV,150MA	07910	1N4152
CR355	152-0185-00			SEMICONV DEVICE:SILICON,40PIV,150MA	07910	1N4152
CR357	152-0185-00			SEMICONV DEVICE:SILICON,40PIV,150MA	07910	1N4152
K44	148-0034-00			RELAY,ARMATURE:DPDT,15VDC,600 OHM	80009	148-0034-00
K48	148-0034-00			RELAY,ARMATURE:DPDT,15VDC,600 OHM	80009	148-0034-00
K138	148-0034-00			RELAY,ARMATURE:DPDT,15VDC,600 OHM	80009	148-0034-00
L100	108-0577-00			COIL,RF:30NH		
L104	108-0577-00			COIL,RF:30NH		
L140	108-0581-00			COIL,RF:100NH		
L141	108-0369-00			COIL,RF:0.12UH	80009	108-0369-00
L146	108-0581-00			COIL,RF:100NH		
L147	108-0369-00			COIL,RF:0.12UH	80009	108-0369-00
L148	108-0578-00			COIL,RF:45NH		
L149	108-0578-00			COIL,RF:45NH		
L170	108-0579-00			TRANSFORMER,RF:120NH	80009	108-0579-00
L171	108-0579-00			TRANSFORMER,RF:120NH	80009	108-0579-00
L304	108-0580-00			COIL,RF:90NH		

Electrical Parts List—7B70 (SN B205000-up)

Ckt No.	Tektronix Part No.	Serial/Model No.		Name & Description	Mfr Code	Mfr Part Number
		Eff	Dscont			
L310	108-0317-00			COIL,RF:15UH	32159	71501M
L318	108-0370-00			COIL,RF:0.14UH	80009	108-0370-00
Q107	151-0220-00			TRANSISTOR:SILICON,PNP	80009	151-0220-00
Q108	151-0220-00			TRANSISTOR:SILICON,PNP	80009	151-0220-00
Q110	151-0220-00			TRANSISTOR:SILICON,PNP	80009	151-0220-00
Q116	151-0220-00			TRANSISTOR:SILICON,PNP	80009	151-0220-00
Q120	151-0224-00			TRANSISTOR:SILICON,NPN	07263	2N3904
Q126	151-0224-00			TRANSISTOR:SILICON,NPN	07263	2N3904
Q131	151-0220-00			TRANSISTOR:SILICON,PNP	80009	151-0220-00
Q134	151-0220-00			TRANSISTOR:SILICON,PNP	80009	151-0220-00
Q150	151-0259-00			TRANSISTOR:SILICON,NPN	80009	151-0259-00
Q156	151-0259-00			TRANSISTOR:SILICON,NPN	80009	151-0259-00
Q158	151-0198-00			TRANSISTOR:SILICON,NPN,SEL FROM MPS918	80009	151-0198-00
Q159	151-0198-00			TRANSISTOR:SILICON,NPN,SEL FROM MPS918	80009	151-0198-00
Q161	151-0188-00			TRANSISTOR:SILICON,PNP	04713	2N3906
Q168	151-0198-00			TRANSISTOR:SILICON,NPN,SEL FROM MPS918	80009	151-0198-00
Q169	151-0198-00			TRANSISTOR:SILICON,NPN,SEL FROM MPS918	80009	151-0198-00
Q170	151-0198-00			TRANSISTOR:SILICON,NPN,SEL FROM MPS918	80009	151-0198-00
Q171	151-0198-00			TRANSISTOR:SILICON,NPN,SEL FROM MPS918	80009	151-0198-00
Q181	151-0223-00			TRANSISTOR:SILICON,NPN	80009	151-0223-00
Q182	151-0223-00			TRANSISTOR:SILICON,NPN	80009	151-0223-00
Q220	151-0221-02			TRANSISTOR:SILICON,PNP		
Q221	151-0221-02			TRANSISTOR:SILICON,PNP		
Q224	151-0190-01			TRANSISTOR:SILICON,NPN	07910	TE23652
Q235	151-0221-02			TRANSISTOR:SILICON,PNP		
Q236	151-0221-02			TRANSISTOR:SILICON,PNP		
Q238	151-0190-01			TRANSISTOR:SILICON,NPN	07910	TE23652
Q248	151-1006-00			TRANSISTOR:SILICON,JFE,N-CHANNEL	15818	U1491
Q255	151-1006-00			TRANSISTOR:SILICON,JFE,N-CHANNEL	15818	U1491
Q309	151-0271-00			TRANSISTOR:SILICON,PNP	01295	SKA4504
Q317	151-0271-00			TRANSISTOR:SILICON,PNP	01295	SKA4504
Q326	151-0190-02			TRANSISTOR:SILICON,NPN	04713	2N3904
Q328	151-0190-02			TRANSISTOR:SILICON,NPN	04713	2N3904
Q331	151-0221-00	B205000	B029999	TRANSISTOR:SILICON,PNP	80009	151-0221-00
Q331	151-0369-00	B230000		TRANSISTOR:SILICON,PNP	01295	SKA6664
Q338	151-0190-01			TRANSISTOR:SILICON,NPN	07910	TE23652
Q339	151-0220-00			TRANSISTOR:SILICON,PNP	80009	151-0220-00
Q346	151-0220-00			TRANSISTOR:SILICON,PNP	80009	151-0220-00
Q348	151-0192-00			TRANSISTOR:SILICON,NPN,SEL FROM MPS6521	80009	151-0192-00
Q350	151-0220-00			TRANSISTOR:SILICON,PNP	80009	151-0220-00
Q360	151-0223-00			TRANSISTOR:SILICON,NPN	80009	151-0223-00
Q368	151-0223-00			TRANSISTOR:SILICON,NPN	80009	151-0223-00
Q370	151-0223-00			TRANSISTOR:SILICON,NPN	80009	151-0223-00
Q377	151-0223-00			TRANSISTOR:SILICON,NPN	80009	151-0223-00
R40	322-0215-00			RES.,FXD,FILM:1.69K OHM,1%,0.25W	75042	CEBT0-1691F
R42	322-0215-00			RES.,FXD,FILM:1.69K OHM,1%,0.25W	75042	CEBT0-1691F
R47	321-0068-00			RES.,FXD,FILM:49.9 OHM,1%,0.125W	75042	CEAT0-49R90F
R49	321-0068-00			RES.,FXD,FILM:49.9 OHM,1%,0.125W	75042	CEAT0-49R90F
R100	315-0560-00			RES.,FXD,COMP:56 OHM,5%,0.25W	01121	CB5605
R101	321-0072-00			RES.,FXD,FILM:54.9 OHM,1%,0.125W	75042	CEAT0-54R90F
R103	321-0072-00			RES.,FXD,FILM:54.9 OHM,1%,0.125W	75042	CEAT0-54R90F
R104	315-0560-00			RES.,FXD,COMP:56 OHM,5%,0.25W	01121	CB5605

Electrical Parts List—7B70 (SN B205000-up)

Ckt No.	Tektronix Part No.	Serial/Model No. Eff	Dscont	Name & Description	Mfr Code	Mfr Part Number
R106	315-0470-00			RES.,FXD,COMP:47 OHM,5%,0.25W	01121	CB4705
R107	321-0046-00			RES.,FXD,FILM:29.4 OHM,1%,0.125W	75042	CEATO-29R40F
R108	315-0470-00			RES.,FXD,COMP:47 OHM,5%,0.25W	01121	CB4705
R110	315-0820-00			RES.,FXD,COMP:82 OHM,5%,0.25W	01121	CB8205
R111	321-0193-00			RES.,FXD,FILM:1K OHM,1%,0.125W	75042	CEATO-1001F
R112	323-0161-00			RES.,FXD,FILM:464 OHM,1%,0.50W	75042	CECTO-4640F
R113	321-0047-00			RES.,FXD,FILM:30.1 OHM,1%,0.125W	75042	CEATO-30R10F
R114	323-0161-00			RES.,FXD,FILM:464 OHM,1%,0.50W	75042	CECTO-4640F
R116	315-0820-00			RES.,FXD,COMP:82 OHM,5%,0.25W	01121	CB8205
R117	321-0193-00			RES.,FXD,FILM:1K OHM,1%,0.125W	75042	CEATO-1001F
R119	321-0288-00			RES.,FXD,FILM:9.76K OHM,1%,0.125W	75042	CEATO-9761F
R120	321-0291-00			RES.,FXD,FILM:10.5K OHM,1%,0.125W	75042	CEATO-1052F
R121	311-1263-00			RES.,VAR,NONWIR:1K OHM,10%,0.50W	73138	62PT-347-0
R122	321-0282-00			RES.,FXD,FILM:8.45K OHM,1%,0.125W	75042	CEATO-8451F
R124	315-0102-00			RES.,FXD,COMP:1K OHM,5%,0.25W	01121	CB1025
R126	321-0288-00			RES.,FXD,FILM:9.76K OHM,1%,0.125W	75042	CEATO-9761F
R127	321-0293-00			RES.,FXD,FILM:11K OHM,1%,0.125W	75042	CEATO-1102F
R128	321-0285-00			RES.,FXD,FILM:9.09K OHM,1%,0.125W	75042	CEATO-9091F
R129	315-0102-00			RES.,FXD,COMP:1K OHM,5%,0.25W	01121	CB1025
R130	315-0152-00			RES.,FXD,COMP:1.5K OHM,5%,0.25W	01121	CB1525
R132	315-0122-00			RES.,FXD,COMP:1.2K OHM,5%,0.25W	01121	CB1225
R133	315-0122-00			RES.,FXD,COMP:1.2K OHM,5%,0.25W	01121	CB1225
R135	315-0361-00			RES.,FXD,COMP:360 OHM,5%,0.25W	01121	CB3615
R136	315-0102-00			RES.,FXD,COMP:1K OHM,5%,0.25W	01121	CB1025
R141	323-0151-00			RES.,FXD,FILM:365 OHM,1%,0.50W	75042	CECTO-3650F
R142	315-0511-00			RES.,FXD,COMP:510 OHM,5%,0.25W	01121	CB5115
R143	321-0115-00			RES.,FXD,FILM:154 OHM,1%,0.125W	75042	CEATO-1540F
R144	321-0115-00			RES.,FXD,FILM:154 OHM,1%,0.125W	75042	CEATO-1540F
R145	315-0511-00			RES.,FXD,COMP:510 OHM,5%,0.25W	01121	CB5115
R147	323-0151-00			RES.,FXD,FILM:365 OHM,1%,0.50W	75042	CECTO-3650F
R148	315-0223-00			RES.,FXD,COMP:22K OHM,5%,0.25W	01121	CB2235
R149	315-0223-00			RES.,FXD,COMP:22K OHM,5%,0.25W	01121	CB2235
R150	315-0560-00			RES.,FXD,COMP:56 OHM,5%,0.25W	01121	CB5605
R152	321-0045-00			RES.,FXD,FILM:28.7 OHM,1%,0.125W	75042	CEATO-28R7F
R153	323-0153-00			RES.,FXD,FILM:383 OHM,1%,0.50W	75042	CECTO-3830F
R154	321-0045-00			RES.,FXD,FILM:28.7 OHM,1%,0.125W	75042	CEATO-28R7F
R155	311-0633-00			RES.,VAR,NONWIR:5K OHM,10%,0.50W	80740	62-58-3
R156	315-0560-00			RES.,FXD,COMP:56 OHM,5%,0.25W	01121	CB5605
R157	315-0510-00			RES.,FXD,COMP:51 OHM,5%,0.25W	01121	CB5105
R158	315-0562-00			RES.,FXD,COMP:5.6K OHM,5%,0.25W	01121	CB5625
R159	315-0122-00			RES.,FXD,COMP:1.2K OHM,5%,0.25W	01121	CB1225
R160	315-0392-00			RES.,FXD,COMP:3.9K OHM,5%,0.25W	01121	CB3925
R163	315-0392-00			RES.,FXD,COMP:3.9K OHM,5%,0.25W	01121	CB3925
R165	315-0432-00			RES.,FXD,COMP:4.3K OHM,5%,0.25W	01121	CB4325
R166	315-0112-00			RES.,FXD,COMP:1.1K OHM,5%,0.25W	01121	CB1125
R167	315-0562-00			RES.,FXD,COMP:5.6K OHM,5%,0.25W	01121	CB5625
R170	321-0096-00			RES.,FXD,FILM:97.6 OHM,1%,0.125W	75042	CEATO-97R60F
R171	321-0096-00			RES.,FXD,FILM:97.6 OHM,1%,0.125W	75042	CEATO-97R60F
R173	315-0201-00			RES.,FXD,COMP:200 OHM,5%,0.25W	01121	CB2015
R175	307-0115-00			RES.,FXD,COMP:7.5 OHM,5%,0.25W	01121	CB75G5
R176	321-0201-00			RES.,FXD,FILM:1.21K OHM,1%,0.125W	75042	CEATO-1211F
R177	307-0115-00			RES.,FXD,COMP:7.5 OHM,5%,0.25W	01121	CB75G5
R178	315-0100-00			RES.,FXD,COMP:10 OHM,5%,0.25W	01121	CB1005

Electrical Parts List—7B70 (SN B205000-up)

Ckt No.	Tektronix Part No.	Serial/Model No. Eff Dscont	Name & Description	Mfr Code	Mfr Part Number
R179	315-0201-00		RES.,FXD,COMP:200 OHM,5%,0.25W	01121	CB2015
R181	315-0113-00		RES.,FXD,COMP:11K OHM,5%,0.25W	01121	CB1135
R182	315-0332-00		RES.,FXD,COMP:3.3K OHM,5%,0.25W	01121	CB3325
R183	321-0229-00		RES.,FXD,FILM:2.37K OHM,1%,0.125W	75042	CEAT0-2371F
R184	321-0229-00		RES.,FXD,FILM:2.37K OHM,1%,0.125W	75042	CEAT0-2371F
R185	315-0822-00		RES.,FXD,COMP:8.2K OHM,5%,0.25W	01121	CB8225
R186	311-0634-00		RES.,VAR,NONWIR:500 OHM,10%,0.50W	80740	62-55-3
R187	321-0313-00		RES.,FXD,FILM:17.8K OHM,1%,0.125W	75042	CEAT0-1782F
R190	315-0203-00		RES.,FXD,COMP:20K OHM,5%,0.25W	01121	CB2035
R191	321-0313-00		RES.,FXD,FILM:17.8K OHM,1%,0.125W	75042	CEAT0-1782F
R201	315-0512-00		RES.,FXD,COMP:5.1K OHM,5%,0.25W	01121	CB5125
R203	315-0512-00		RES.,FXD,COMP:5.1K OHM,5%,0.25W	01121	CB5125
R205	315-0104-00		RES.,FXD,COMP:100K OHM,5%,0.25W	01121	CB1045
R209	315-0512-00		RES.,FXD,COMP:5.1K OHM,5%,0.25W	01121	CB5125
R210	315-0221-00		RES.,FXD,COMP:220 OHM,5%,0.25W	01121	CB2215
R212	315-0221-00		RES.,FXD,COMP:220 OHM,5%,0.25W	01121	CB2215
R214	315-0155-00		RES.,FXD,COMP:1.5M OHM,5%,0.25W	01121	CB1555
R215	315-0472-00		RES.,FXD,COMP:4.7K OHM,5%,0.25W	01121	CB4725
R217	315-0124-00		RES.,FXD,COMP:120K OHM,5%,0.25W	01121	CB1245
R219	315-0153-00		RES.,FXD,COMP:15K OHM,5%,0.25W	01121	CB1535
R221	315-0162-00		RES.,FXD,COMP:1.6K OHM,5%,0.25W	01121	CB1625
R225	307-0112-00		RES.,FXD,COMP:4.3 OHM,5%,0.25W	01121	CB43G5
R230	315-0155-00		RES.,FXD,COMP:1.5M OHM,5%,0.25W	01121	CB1555
R231	315-0472-00		RES.,FXD,COMP:4.7K OHM,5%,0.25W	01121	CB4725
R233	315-0124-00		RES.,FXD,COMP:120K OHM,5%,0.25W	01121	CB1245
R234	315-0153-00		RES.,FXD,COMP:15K OHM,5%,0.25W	01121	CB1535
R235	315-0162-00		RES.,FXD,COMP:1.6K OHM,5%,0.25W	01121	CB1625
R239	307-0112-00		RES.,FXD,COMP:4.3 OHM,5%,0.25W	01121	CB43G5
R241	315-0106-00		RES.,FXD,COMP:10M OHM,5%,0.25W	01121	CB1065
R243	315-0474-00		RES.,FXD,COMP:470K OHM,5%,0.25W	01121	CB4745
R244	315-0623-00		RES.,FXD,COMP:62K OHM,5%,0.25W	01121	CB6235
R246	315-0106-00		RES.,FXD,COMP:10M OHM,5%,0.25W	01121	CB1065
R248	315-0510-00		RES.,FXD,COMP:51 OHM,5%,0.25W	01121	CB5105
R250	321-0240-00		RES.,FXD,FILM:3.09K OHM,1%,0.125W	75042	CEAT0-3091F
R251	311-1259-00		RES.,VAR,NONWIR:100 OHM,10%,0.50W	80294	3329P-L58-101
R252	321-0219-00		RES.,FXD,FILM:1.87K OHM,1%,0.125W	75042	CEAT0-1871F
R253	321-0260-00		RES.,FXD,FILM:4.99K OHM,1%,0.125W	75042	CEAT0-4991F
R255	315-0510-00		RES.,FXD,COMP:51 OHM,5%,0.25W	01121	CB5105
R257	321-0240-00		RES.,FXD,FILM:3.09K OHM,1%,0.125W	75042	CEAT0-3091F
R258	311-1259-00		RES.,VAR,NONWIR:100 OHM,10%,0.50W	80294	3329P-L58-101
R259	321-0219-00		RES.,FXD,FILM:1.87K OHM,1%,0.125W	75042	CEAT0-1871F
R260	321-0260-00		RES.,FXD,FILM:4.99K OHM,1%,0.125W	75042	CEAT0-4991F
R265	315-0102-00		RES.,FXD,COMP:1K OHM,5%,0.25W	01121	CB1025
R275	321-0289-00		RES.,FXD,FILM:10K OHM,1%,0.125W	75042	CEAT0-1002F
R282	315-0102-00		RES.,FXD,COMP:1K OHM,5%,0.25W	01121	CB1025
R284	315-0123-00		RES.,FXD,COMP:12K OHM,5%,0.25W	01121	CB1235
R300	315-0620-00		RES.,FXD,COMP:62 OHM,5%,0.25W	01121	CB6205
R301	321-0158-00		RES.,FXD,FILM:432 OHM,1%,0.125W	75042	CEAT0-4320F
R302	321-0135-00		RES.,FXD,FILM:249 OHM,1%,0.125W	75042	CEAT0-2490F
R303	315-0430-00		RES.,FXD,COMP:43 OHM,5%,0.25W	01121	CB4305
R306	315-0620-00		RES.,FXD,COMP:62 OHM,5%,0.25W	01121	CB6205
R307	321-0177-00		RES.,FXD,FILM:681 OHM,1%,0.125W	75042	CEAT0-6810F
R310	315-0471-00		RES.,FXD,COMP:470 OHM,5%,0.25W	01121	CB4715

Electrical Parts List—7B70 (SN B205000-up)

Ckt No.	Tektronix Part No.	Serial/Model No. Eff	Model No. Dscont	Name & Description	Mfr Code	Mfr Part Number
R312	315-0100-00			RES.,FXD,COMP:10 OHM,5%,0.25W	01121	CB1005
R313	321-0201-00			RES.,FXD,FILM:1.21K OHM,1%,0.125W	75042	CEATO-1211F
R315	315-0200-00			RES.,FXD,COMP:20 OHM,5%,0.25W	01121	CB2005
R318	315-0151-00			RES.,FXD,COMP:150 OHM,5%,0.25W	01121	CB1515
R319	315-0752-00			RES.,FXD,COMP:7.5K OHM,5%,0.25W	01121	CB7525
R320	315-0751-00			RES.,FXD,COMP:750 OHM,5%,0.25W	01121	CB7515
R322	315-0391-00			RES.,FXD,COMP:390 OHM,5%,0.25W	01121	CB3915
R324	315-0301-00			RES.,FXD,COMP:300 OHM,5%,0.25W	01121	CB3015
R326	315-0200-00			RES.,FXD,COMP:20 OHM,5%,0.25W	01121	CB2005
R327	315-0242-00			RES.,FXD,COMP:2.4K OHM,5%,0.25W	01121	CB2425
R328	315-0152-00			RES.,FXD,COMP:1.5K OHM,5%,0.25W	01121	CB1525
R329	315-0200-00			RES.,FXD,COMP:20 OHM,5%,0.25W	01121	CB2005
R331	321-0161-00			RES.,FXD,FILM:464 OHM,1%,0.125W	75042	CEATO-4640F
R333	315-0102-00			RES.,FXD,COMP:1K OHM,5%,0.25W	01121	CB1025
R334	315-0183-00			RES.,FXD,COMP:18K OHM,5%,0.25W	01121	CB1835
R335	315-0202-00			RES.,FXD,COMP:2K OHM,5%,0.25W	01121	CB2025
R336	315-0102-00			RES.,FXD,COMP:1K OHM,5%,0.25W	01121	CB1025
R339	315-0471-00			RES.,FXD,COMP:470 OHM,5%,0.25W	01121	CB4715
R340	315-0102-00			RES.,FXD,COMP:1K OHM,5%,0.25W	01121	CB1025
R341	315-0303-00			RES.,FXD,COMP:30K OHM,5%,0.25W	01121	CB3035
R342	315-0102-00			RES.,FXD,COMP:1K OHM,5%,0.25W	01121	CB1025
R343	315-0154-00			RES.,FXD,COMP:150K OHM,5%,0.25W	01121	CB1545
R344	315-0223-00			RES.,FXD,COMP:22K OHM,5%,0.25W	01121	CB2235
R346	315-0302-00			RES.,FXD,COMP:3K OHM,5%,0.25W	01121	CB3025
R353	321-0321-00			RES.,FXD,FILM:21.5K OHM,1%,0.125W	75042	CEATO-2152F
R354	321-0285-00			RES.,FXD,FILM:9.09K OHM,1%,0.125W	75042	CEATO-9091F
R356	321-0177-00			RES.,FXD,FILM:681 OHM,1%,0.125W	75042	CEATO-6810F
R357	321-0239-00			RES.,FXD,FILM:3.01K OHM,1%,0.125W	75042	CEATO-3011F
R361	321-0126-00			RES.,FXD,FILM:200 OHM,1%,0.125W	75042	CEATO-2000F
R363	307-0111-00			RES.,FXD,COMP:3.6 OHM,5%,0.25W	01121	CB36G5
R364	321-0144-00			RES.,FXD,FILM:309 OHM,1%,0.125W	75042	CEATO-3090F
R366	321-0122-00			RES.,FXD,FILM:182 OHM,1%,0.125W	75042	CEATO-1820F
R367	321-0030-00			RES.,FXD,FILM:20 OHM,1%,0.125W	75042	CEATO-20ROF
R370	323-0192-00			RES.,FXD,FILM:976 OHM,1%,0.50W	75042	CECTO-9760F
R371	315-0103-00			RES.,FXD,COMP:10K OHM,5%,0.25W	01121	CB1035
R372	315-0103-00			RES.,FXD,COMP:10K OHM,5%,0.25W	01121	CB1035
R374	315-0101-00			RES.,FXD,COMP:100 OHM,5%,0.25W	01121	CB1015
R377	315-0391-00			RES.,FXD,COMP:390 OHM,5%,0.25W	01121	CB3915
R379	315-0182-00			RES.,FXD,COMP:1.8K OHM,5%,0.25W	01121	CB1825
R380	315-0100-00			RES.,FXD,COMP:10 OHM,5%,0.25W	01121	CB1005
R401	307-0106-00			RES.,FXD,COMP:4.7 OHM,5%,0.25W	01121	CB47G5
R402	307-0106-00			RES.,FXD,COMP:4.7 OHM,5%,0.25W	01121	CB47G5
R403	307-0106-00			RES.,FXD,COMP:4.7 OHM,5%,0.25W	01121	CB47G5
R405	307-0106-00			RES.,FXD,COMP:4.7 OHM,5%,0.25W	01121	CB47G5
U192	156-0077-00			MICROCIRCUIT,LI:SINGLE OPERATIONAL AMP		
U260	156-0049-00			MICROCIRCUIT,LI:OPERATING AMPLIFIER	07263	U5B7741393
U267	156-0049-00			MICROCIRCUIT,LI:OPERATING AMPLIFIER	07263	U5B7741393
VR304	152-0141-02			SEMICONV DEVICE:SILICON,30V,150MA	07910	1N4152
VR322	152-0125-00			SEMICONV DEVICE:TUNNEL,15PF,4.7MA	03508	STD704
VR358	152-0125-00			SEMICONV DEVICE:TUNNEL,15PF,4.7MA	03508	STD704

Electrical Parts List—7B70 (SN B205000-up)

Ckt No.	Tektronix Part No.	Serial/Model No. Eff	Dscont	Name & Description	Mfr Code	Mfr Part Number
	670-1137-03			CKT BOARD ASSY:INTERFACE	80009	670-1137-03
C280	290-0267-00			CAP. ,FXD,ELCTLT:1UF,20%,35V	56289	162D105X0035CD2
C530P	281-0523-00			CAP. ,FXD,CER DI:500PF,+/-20PF,350V	72982	301-000U2M0101M
C530R	281-0536-00			CAP. ,FXD,CER DI:1000PF,10%,500V	72982	301-055X5P0102K
C530S	283-0599-00			CAP. ,FXD,MICA D:98PF,5%,500V	00853	D10E980J0500
CR44	152-0185-00			SEMICONV DEVICE:SILICON,40PIV,150MA	07910	1N4152
CR461	152-0185-00			SEMICONV DEVICE:SILICON,40PIV,150MA	07910	1N4152
CR531	152-0185-00			SEMICONV DEVICE:SILICON,40PIV,150MA	07910	1N4152
CR702	152-0185-00			SEMICONV DEVICE:SILICON,40PIV,150MA	07910	1N4152
R197	315-0123-00			RES. ,FXD,COMP:12K OHM,5%,0.25W	01121	CB1235
R280	315-0513-00			RES. ,FXD,COMP:51K OHM,5%,0.25W	01121	CB5135
R347	315-0200-00			RES. ,FXD,COMP:20 OHM,5%,0.25W	01121	CB2005
R460	315-0472-00			RES. ,FXD,COMP:4.7K OHM,5%,0.25W	01121	CB4725
R461	315-0752-00			RES. ,FXD,COMP:7.5K OHM,5%,0.25W	01121	CB7525
R530A	323-0568-08			RES. ,FXD,FILM:8.06M OHM,1%,0.50W		
R530B	323-0557-08			RES. ,FXD,FILM:6.19M OHM,1%,0.50W		
R530C	323-0546-08			RES. ,FXD,FILM:4.75M OHM,1%,0.50W		
R530D	323-0546-08			RES. ,FXD,FILM:4.75M OHM,1%,0.50W		
R530F	323-0767-07			RES. ,FXD,FILM:1.425M OHM,0.5%,0.50W		
R530H	323-0450-07			RES. ,FXD,FILM:475K OHM,0.1%,0.50W		
R530J	323-0450-07			RES. ,FXD,FILM:475K OHM,0.1%,0.50W		
R530K	323-0774-07			RES. ,FXD,FILM:118.7K OHM,0.1%,0.50W		
R530L	323-0354-07			RES. ,FXD,FILM:47.5K OHM,0.25%,0.50W	75042	CECT9-4752B
R530M	321-0267-00			RES. ,FXD,FILM:5.9K OHM,1%,0.125W	75042	CEAT0-5901F
R530N	323-0775-07			RES. ,FXD,FILM:71.25K OHM,0.1%,0.50W		
R530P	315-0330-00			RES. ,FXD,COMP:33 OHM,5%,0.25W	01121	CB3305
R530R	315-0220-00			RES. ,FXD,COMP:22 OHM,5%,0.25W	01121	CB2205
R530S	315-0390-00			RES. ,FXD,COMP:39 OHM,5%,0.25W	01121	CB3905
R531	311-0959-00			RES. ,VAR,WW10K OHM,5%,1.5W	71590	BA165-007
R701	315-0154-00			RES. ,FXD,COMP:150K OHM,5%,0.25W	01121	CB1545
R702	315-0133-00			RES. ,FXD,COMP:13K OHM,5%,0.25W	01121	CB1335
R704	315-0154-00			RES. ,FXD,COMP:150K OHM,5%,0.25W	01121	CB1545
R705	321-0344-00			RES. ,FXD,FILM:37.4K OHM,1%,0.125W	75042	CEAT0-3742F
R706	315-0753-00			RES. ,FXD,COMP:75K OHM,5%,0.25W	01121	CB7535
R711	315-0753-00			RES. ,FXD,COMP:75K OHM,5%,0.25W	01121	CB7535
R712	315-0154-00			RES. ,FXD,COMP:150K OHM,5%,0.25W	01121	CB1545
R713	315-0753-00			RES. ,FXD,COMP:75K OHM,5%,0.25W	01121	CB7535
R715	315-0154-00			RES. ,FXD,COMP:150K OHM,5%,0.25W	01121	CB1545
R721	315-0753-00			RES. ,FXD,COMP:75K OHM,5%,0.25W	01121	CB7535
R722	315-0154-00			RES. ,FXD,COMP:150K OHM,5%,0.25W	01121	CB1545
R723	315-0154-00			RES. ,FXD,COMP:150K OHM,5%,0.25W	01121	CB1545
R724	321-0356-00			RES. ,FXD,FILM:49.9K OHM,1%,0.125W	75042	CEAT0-4992F
R727	321-0335-00			RES. ,FXD,FILM:30.1K OHM,1%,0.125W	75042	CEAT0-3012F
R728	321-0344-00			RES. ,FXD,FILM:37.4K OHM,1%,0.125W	75042	CEAT0-3742F
R729	315-0154-00			RES. ,FXD,COMP:150K OHM,5%,0.25W	01121	CB1545
S530 ¹	670-1137-03			ACTR ASSY,CAM S:TIME/DIV	80009	670-1137-03
S531 ²				CAL IN		

¹See Mechanical Partt List for replacement parts.

²Furnished as a unit with S530.

Electrical Parts List—7B70 (SN B205000-up)

Ckt No.	Tektronix Part No.	Serial/Model No. Eff Dscont	Name & Description	Mfr Code	Mfr Part Number
	670-1139-04		CKT BOARD ASSY:DISPLAY MODE	80009	670-1139-04
DS195	150-0048-01		LAMP, INCAND:NO. 683 ,SELECTED	08806	683AS15
R264	321-0338-00		RES. ,FXD,FILM:32.4K OHM,1%,0.125W	75042	CEATO-3242F
S195 ¹	670-1139-04		PUSH BUTTON:TIME/BASE-AMPLIFIER	80009	670-1139-04
	670-1146-02		CKT BOARD ASSY:COUPLING	80009	670-1146-02
DS270	150-0048-01		LAMP, INCAND:NO. 683 ,SELECTED	08806	683AS15
C270	283-0026-00		CAP. ,FXD,CER DI:0.2UF,+80-20%,25V	56289	274C3
R271	321-0325-00		RES. ,FXD,FILM:23.7K OHM,1%,0.125W	75042	CEATO-2372F
S270 ¹	670-1146-02		PUSH BUTTON:COUPLING	80009	670-1146-02
	670-1140-02		CKT BOARD ASSY:MODE	80009	670-1140-02
DS274	150-0048-01		LAMP, INCAND:NO. 683 ,SELECTED	08806	683AS15
DS446	150-0048-01		LAMP, INCAND:NO. 683 ,SELECTED	08806	683AS15
R273	321-0305-00		RES. ,FXD,FILM:14.7K OHM,1%,0.125W	75042	CEATO-1472F
S273 ¹	670-1140-02		PUSH BUTTON:MODE	80009	670-1140-02
	670-1138-04		CKT BOARD ASSY:TIME BASE	80009	670-1138-04
C404	283-0080-00		CAP. ,FXD,CER DI:0.022UF,+80-20%,25V	56289	19C611
C407	283-0080-00		CAP. ,FXD,CER DI:0.022UF,+80-20%,25V	56289	19C611
C421	283-0080-00		CAP. ,FXD,CER DI:0.022UF,+80-20%,25V	56289	19C611
C431	283-0080-00		CAP. ,FXD,CER DI:0.022UF,+80-20%,25V	56289	19C611
C434	281-0577-00		CAP. ,FXD,CER DI:14PF,5%,500V	72982	301-050C0G0140J
C441	283-0080-00		CAP. ,FXD,CER DI:0.022UF,+80-20%,25V	56289	19C611
C446	290-0136-00		CAP. ,FXD,ELCTLT:2.2UF,20%,20V	56289	162D225X0020CD2
C456	290-0136-00		CAP. ,FXD,ELCTLT:2.2UF,20%,20V	56289	162D225X0020CD2
C457	281-0524-00		CAP. ,FXD,CER DI:150PF,+/-30PF,500V	72982	301-000X5U0151M
C466	283-0080-00		CAP. ,FXD,CER DI:0.022UF,+80-20%,25V	56289	19C611
C469	283-0000-00		CAP. ,FXD,CER DI:0.001UF,+100-0%,500V	72982	831-516E102P
C523	281-0603-00		CAP. ,FXD,CER DI:39PF,5%,500V	72982	308-000C0G0390J
C524	281-0524-00		CAP. ,FXD,CER DI:150PF,+/-30PF,500V	72982	301-000X5U0151M
C527	281-0523-00		CAP. ,FXD,CER DI:500PF,+/-20PF,350V	72982	301-000U2M0101M
C530J	281-0093-00		CAP. ,VAR,CER DI:5.5-18PF	72982	538-011C0P092R
C530K	283-0126-00		CAP. ,FXD,CER DI:82PF,5%,1000V	56289	33C180
C530L	281-0091-00		CAP. ,VAR,CER DI:2-8PF	72982	538-011-89A

¹See Mechanical Parts List for replacement parts.

Electrical Parts List—7B70 (SN B205000-up)

Ckt No.	Tektronix Part No.	Serial/Model No. Eff	Dscont	Name & Description	Mfr Code	Mfr Part Number
C530M	281-0657-00			CAP. ,FXD,CER DI :13PF,2%,500V	72982	374-005C0G0130G
C532	283-0080-00			CAP. ,FXD,CER DI :0.022UF,+80-20%,25V	56289	19C611
C536	290-0136-00			CAP. ,FXD,ELCTLT:2.2UF,20%,20V	56289	162D225X0020CD2
C537	281-0160-00			CAP. ,VAR,CER DI :7-25PF,350V	72982	538-011B7-25
C545	290-0136-00			CAP. ,FXD,ELCTLT:2.2UF,20%,20V	56289	162D225X0020CD2
C551	281-0523-00			CAP. ,FXD,CER DI :500PF,+/-20PF,350V	72982	301-000U2M0101M
C556	281-0552-00			CAP. ,FXD,CER DI :25PF,5%,500V	72982	301-000P2G0250J
C561	290-0136-00			CAP. ,FXD,ELCTLT:2.2UF,20%,20V	56289	162D225X0020CD2
C580A	283-0164-00			CAP. ,FXD,CER DI :2.2UF,20%,25V	72982	8141N038651225M
C580B	283-0191-00			CAP. ,FXD,CER DI :0.022UF,20%,50V	72982	8121N063651223M
C580D	283-0666-00			CAP. ,FXD,MICA D:890PF,2%,100V	00853	D151F891G0
C583	283-0080-00			CAP. ,FXD,CER DI :0.022UF,+80-20%,25V	56289	19C611
C592	281-0546-00			CAP. ,FXD,CER DI :330PF,10%,500V	72982	301-000X5P0331K
C746	283-0191-00			CAP. ,FXD,CER DI :0.022UF,20%,50V	72982	8121N063651223M
C748	283-0191-00			CAP. ,FXD,CER DI :0.022UF,20%,50V	72982	8121N063651223M
C752	281-0501-00			CAP. ,FXD,CER DI :4.7PF,+/-1PF,500V	72982	301-000S2H0479F
C780	281-0508-00			CAP. ,FXD,CER DI :12PF,+/-0.6PF,500V	72982	301-000C0G0120J
C787	281-0549-00			CAP. ,FXD,CER DI :68PF,10%,500V	72982	301-000U2J0680K
C788	290-0527-00			CAP. ,FXD,ELCTLT:15UF,20%,20V	90201	TDC156M020NLF
C789	283-0067-00			CAP. ,FXD,CER DI :0.001UF,10%,200V	72982	835-515B102K
C799	290-0136-00			CAP. ,FXD,ELCTLT:2.2UF,20%,20V	56289	162D225X0020CD2
C801	290-0420-00			CAP. ,FXD,ELCTLT:0.68UF,20%,75V	56289	150D684X0075A2
C803	290-0136-00			CAP. ,FXD,ELCTLT:2.2UF,20%,20V	56289	162D225X0020CD2
C805	290-0136-00			CAP. ,FXD,ELCTLT:2.2UF,20%,20V	56289	162D225X0020CD2
C807	290-0136-00			CAP. ,FXD,ELCTLT:2.2UF,20%,20V	56289	162D225X0020CD2
C809	283-0080-00			CAP. ,FXD,CER DI :0.022UF,+80-20%,25V	56289	19C611
C813	290-0136-00			CAP. ,FXD,ELCTLT:2.2UF,20%,20V	56289	162D225X0020CD2
C815	290-0136-00			CAP. ,FXD,ELCTLT:2.2UF,20%,20V	56289	162D225X0020CD2
C817	290-0136-00			CAP. ,FXD,ELCTLT:2.2UF,20%,20V	56289	162D225X0020CD2
C819	290-0136-00			CAP. ,FXD,ELCTLT:2.2UF,20%,20V	56289	162D225X0020CD2
C821	290-0420-00			CAP. ,FXD,ELCTLT:0.68UF,20%,75V	56289	150D684X0075A2
CR406	152-0185-00			SEMICONV DEVICE:SILICON,40PIV,150MA	07910	1N4152
CR412	152-0185-00			SEMICONV DEVICE:SILICON,40PIV,150MA	07910	1N4152
CR413	152-0185-00			SEMICONV DEVICE:SILICON,40PIV,150MA	07910	1N4152
CR414	152-0185-00			SEMICONV DEVICE:SILICON,40PIV,150MA	07910	1N4152
CR419	152-0185-00			SEMICONV DEVICE:SILICON,40PIV,150MA	07910	1N4152
CR427	152-0185-00			SEMICONV DEVICE:SILICON,40PIV,150MA	07910	1N4152
CR428	152-0185-00			SEMICONV DEVICE:SILICON,40PIV,150MA	07910	1N4152
CR431	152-0185-00			SEMICONV DEVICE:SILICON,40PIV,150MA	07910	1N4152
CR436	152-0185-00			SEMICONV DEVICE:SILICON,40PIV,150MA	07910	1N4152
CR446	152-0185-00			SEMICONV DEVICE:SILICON,40PIV,150MA	07910	1N4152
CR448	152-0185-00			SEMICONV DEVICE:SILICON,40PIV,150MA	07910	1N4152
CR449	152-0185-00			SEMICONV DEVICE:SILICON,40PIV,150MA	07910	1N4152
CR451	152-0185-00			SEMICONV DEVICE:SILICON,40PIV,150MA	07910	1N4152
CR452	152-0185-00			SEMICONV DEVICE:SILICON,40PIV,150MA	07910	1N4152
CR453	152-0185-00			SEMICONV DEVICE:SILICON,40PIV,150MA	07910	1N4152
CR454	152-0185-00			SEMICONV DEVICE:SILICON,40PIV,150MA	07910	1N4152
CR459	152-0185-00			SEMICONV DEVICE:SILICON,40PIV,150MA	07910	1N4152
CR462	152-0185-00			SEMICONV DEVICE:SILICON,40PIV,150MA	07910	1N4152
CR463	152-0185-00			SEMICONV DEVICE:SILICON,40PIV,150MA	07910	1N4152
CR464	152-0185-00			SEMICONV DEVICE:SILICON,40PIV,150MA	07910	1N4152
CR465	152-0185-00			SEMICONV DEVICE:SILICON,40PIV,150MA	07910	1N4152

Electrical Parts List—7B70 (SN B205000-up)

Ckt No.	Tektronix Part No.	Serial/Model No. Eff Dscont	Name & Description	Mfr Code	Mfr Part Number
CR466	152-0185-00		SEMICONV DEVICE:SILICON,40PIV,150MA	07910	1N4152
CR467	152-0185-00		SEMICONV DEVICE:SILICON,40PIV,150MA	07910	1N4152
CR468	152-0185-00		SEMICONV DEVICE:SILICON,40PIV,150MA	07910	1N4152
CR469	152-0185-00		SEMICONV DEVICE:SILICON,40PIV,150MA	07910	1N4152
CR523	152-0141-02		SEMICONV DEVICE:SILICON,30V,150MA	07910	1N4152
CR525	152-0185-00		SEMICONV DEVICE:SILICON,40PIV,150MA	07910	1N4152
CR528	152-0185-00		SEMICONV DEVICE:SILICON,40PIV,150MA	07910	1N4152
CR529	152-0246-00		SEMICONV DEVICE:SILICON,40PIV,200MA	07910	CD12676
CR548	152-0141-02		SEMICONV DEVICE:SILICON,30V,150MA	07910	1N4152
CR571	152-0185-00		SEMICONV DEVICE:SILICON,40PIV,150MA	07910	1N4152
CR572	152-0185-00		SEMICONV DEVICE:SILICON,40PIV,150MA	07910	1N4152
CR574	152-0185-00		SEMICONV DEVICE:SILICON,40PIV,150MA	07910	1N4152
CR575	152-0185-00		SEMICONV DEVICE:SILICON,40PIV,150MA	07910	1N4152
CR576	152-0185-00		SEMICONV DEVICE:SILICON,40PIV,150MA	07910	1N4152
CR580	152-0185-00		SEMICONV DEVICE:SILICON,40PIV,150MA	07910	1N4152
CR581	152-0185-00		SEMICONV DEVICE:SILICON,40PIV,150MA	07910	1N4152
CR582	152-0185-00		SEMICONV DEVICE:SILICON,40PIV,150MA	07910	1N4152
CR592	152-0185-00		SEMICONV DEVICE:SILICON,40PIV,150MA	07910	1N4152
CR594	152-0185-00		SEMICONV DEVICE:SILICON,40PIV,150MA	07910	1N4152
CR598	152-0185-00		SEMICONV DEVICE:SILICON,40PIV,150MA	07910	1N4152
CR763	152-0141-02		SEMICONV DEVICE:SILICON,30V,150MA	07910	1N4152
K780	148-0034-00		RELAY,ARMATURE:DPDT,15VDC,600 OHM	80009	148-0034-00
L593	108-0440-00		COIL,RF:8UH,TOROIDAL INDUCTOR	80009	108-0440-00
L594	108-0440-00		COIL,RF:8UH,TOROIDAL INDUCTOR	80009	108-0440-00
Q406	151-0190-01		TRANSISTOR:SILICON,NPN	07910	TE23652
Q408	151-0190-01		TRANSISTOR:SILICON,NPN	07910	TE23652
Q410	151-0188-00		TRANSISTOR:SILICON,PNP	04713	2N3906
Q416	151-0190-01		TRANSISTOR:SILICON,NPN	07910	TE23652
Q424	151-0190-01		TRANSISTOR:SILICON,NPN	07910	TE23652
Q432	151-0188-00		TRANSISTOR:SILICON,PNP	04713	2N3906
Q436	151-0188-00		TRANSISTOR:SILICON,PNP	04713	2N3906
Q442	151-0188-00		TRANSISTOR:SILICON,PNP	04713	2N3906
Q446	151-0207-00		TRANSISTOR:SILICON,NPN	03508	GET3415
Q454	151-0190-01		TRANSISTOR:SILICON,NPN	07910	TE23652
Q456	151-0190-01		TRANSISTOR:SILICON,NPN	07910	TE23652
Q468	151-0190-01		TRANSISTOR:SILICON,NPN	07910	TE23652
Q524	151-0188-00		TRANSISTOR:SILICON,PNP	04713	2N3906
Q526	151-0289-00		TRANSISTOR:SILICON,PNP		
Q532A,B	151-1036-00		TRANSISTOR:SILICON,JFE,N-CHANNEL,DUAL	21845	FD1551
Q534	151-0188-00		TRANSISTOR:SILICON,PNP	04713	2N3906
Q537	151-0190-01		TRANSISTOR:SILICON,NPN	07910	TE23652
Q546	151-0220-00		TRANSISTOR:SILICON,PNP	80009	151-0220-00
Q554	151-0190-01		TRANSISTOR:SILICON,NPN	07910	TE23652
Q564	151-0190-01		TRANSISTOR:SILICON,NPN	07910	TE23652
Q566	151-0190-01		TRANSISTOR:SILICON,NPN	07910	TE23652
Q582	151-0188-00		TRANSISTOR:SILICON,PNP	04713	2N3906
Q592A,B	151-0232-00		TRANSISTOR:SILICON,NPN,DUAL	12040	NS7348
Q594	151-0333-00		TRANSISTOR:SILICON,NPN,SEL FROM MPS918	80009	151-0333-00
Q784	151-0325-00		TRANSISTOR:SILICON,PNP,SEL FROM 2N4258	80009	151-0325-00
Q794	151-0325-00		TRANSISTOR:SILICON,PNP,SEL FROM 2N4258	80009	151-0325-00

Electrical Parts List—7B70 (SN B205000-up)

Ckt No.	Tektronix Part No.	Serial/Model No. Eff	Dscont	Name & Description	Mfr Code	Mfr Part Number
R404	315-0151-00			RES., FXD, COMP:150 OHM, 5%, 0.25W	01121	CB1515
R406	315-0103-00			RES., FXD, COMP:10K OHM, 5%, 0.25W	01121	CB1035
R407	315-0151-00			RES., FXD, COMP:150 OHM, 5%, 0.25W	01121	CB1515
R408	321-0174-00			RES., FXD, FILM:634 OHM, 1%, 0.125W	75042	CEATO-6340F
R409	321-0252-00	B205000	B229999	RES., FXD, FILM:4.12K OHM, 1%, 0.125W	75042	CEATO-4121F
R409	321-0246-00	B230000		RES., FXD, FILM:3.57K OHM, 1%, 0.125W	75042	CEATO-3571F
R410	315-0101-00			RES., FXD, COMP:100 OHM, 5%, 0.25W	01121	CB1015
R411	321-0277-00			RES., FXD, FILM:7.5K OHM, 1%, 0.125W	75042	CEATO-7501F
R412	315-0153-00			RES., FXD, COMP:15K OHM, 5%, 0.25W	01121	CB1535
R416	321-0315-00			RES., FXD, FILM:18.7K OHM, 1%, 0.125W	75042	CEATO-1872F
R418	315-0202-00			RES., FXD, COMP:2K OHM, 5%, 0.25W	01121	CB2025
R419	315-0221-00			RES., FXD, COMP:220 OHM, 5%, 0.25W	01121	CB2215
R421	315-0431-00			RES., FXD, COMP:430 OHM, 5%, 0.25W	01121	CB4315
R422	315-0112-00			RES., FXD, COMP:1.1K OHM, 5%, 0.25W	01121	CB1125
R423	315-0220-00			RES., FXD, COMP:22 OHM, 5%, 0.25W	01121	CB2205
R424	315-0302-00			RES., FXD, COMP:3K OHM, 5%, 0.25W	01121	CB3025
R426	315-0132-00			RES., FXD, COMP:1.3K OHM, 5%, 0.25W	01121	CB1325
R427	315-0561-00			RES., FXD, COMP:560 OHM, 5%, 0.25W	01121	CB5615
R428	321-0300-00			RES., FXD, FILM:13K OHM, 1%, 0.125W	75042	CEATO-1302F
R431	315-0470-00			RES., FXD, COMP:47 OHM, 5%, 0.25W	01121	CB4705
R432	321-0136-00			RES., FXD, FILM:255 OHM, 1%, 0.125W	75042	CEATO-2550F
R433	321-0129-00			RES., FXD, FILM:215 OHM, 1%, 0.125W	75042	CEATO-2150F
R434	321-0265-00			RES., FXD, FILM:5.62K OHM, 1%, 0.125W	75042	CEATO-5621F
R435	321-0244-00			RES., FXD, FILM:3.4K OHM, 1%, 0.125W	75042	CEATO-3401F
R436	321-0167-00			RES., FXD, FILM:536 OHM, 1%, 0.125W	75042	CEATO-5360F
R438	315-0102-00			RES., FXD, COMP:1K OHM, 5%, 0.25W	01121	CB1025
R441	301-0470-00			RES., FXD, COMP:47 OHM, 5%, 0.50W	01121	EB4705
R444	315-0102-00			RES., FXD, COMP:1K OHM, 5%, 0.25W	01121	CB1025
R448	321-0277-00			RES., FXD, FILM:7.5K OHM, 1%, 0.125W	75042	CEATO-7501F
R449	315-0472-00			RES., FXD, COMP:4.7K OHM, 5%, 0.25W	01121	CB4725
R451	315-0223-00			RES., FXD, COMP:22K OHM, 5%, 0.25W	01121	CB2235
R452	321-0306-00			RES., FXD, FILM:15K OHM, 1%, 0.125W	75042	CEATO-1502F
R454	315-0472-00			RES., FXD, COMP:4.7K OHM, 5%, 0.25W	01121	CB4725
R455	315-0682-00			RES., FXD, COMP:6.8K OHM, 5%, 0.25W	01121	CB6825
R456	315-0153-00			RES., FXD, COMP:15K OHM, 5%, 0.25W	01121	CB1535
R458	315-0103-00			RES., FXD, COMP:10K OHM, 5%, 0.25W	01121	CB1035
R459	315-0123-00			RES., FXD, COMP:12K OHM, 5%, 0.25W	01121	CB1235
R462	315-0752-00			RES., FXD, COMP:7.5K OHM, 5%, 0.25W	01121	CB7525
R464	321-0271-00			RES., FXD, FILM:6.49K OHM, 1%, 0.125W	75042	CEATO-6491F
R465	321-0234-00			RES., FXD, FILM:2.67K OHM, 1%, 0.125W	75042	CEATO-2671F
R466	321-0277-00			RES., FXD, FILM:7.5K OHM, 1%, 0.125W	75042	CEATO-7501F
R468	321-0306-00			RES., FXD, FILM:15K OHM, 1%, 0.125W	75042	CEATO-1502F
R469	321-0209-00			RES., FXD, FILM:1.47K OHM, 1%, 0.125W	75042	CEATO-1471F
R521	315-0101-00			RES., FXD, COMP:100 OHM, 5%, 0.25W	01121	CB1015
R522	315-0203-00			RES., FXD, COMP:20K OHM, 5%, 0.25W	01121	CB2035
R523	321-0266-00			RES., FXD, FILM:5.76K OHM, 1%, 0.125W	75042	CEATO-5761F
R524	315-0222-00			RES., FXD, COMP:2.2K OHM, 5%, 0.25W	01121	CB2225
R525	321-0289-00			RES., FXD, FILM:10K OHM, 1%, 0.125W	75042	CEATO-1002F
R526	321-0269-00			RES., FXD, FILM:6.19K OHM, 1%, 0.125W	75042	CEATO-6191F
R527	321-0193-00			RES., FXD, FILM:1K OHM, 1%, 0.125W	75042	CEATO-1001F
R532	315-0122-00			RES., FXD, COMP:1.2K OHM, 5%, 0.25W	01121	CB1225
R533	321-0219-00			RES., FXD, FILM:1.87K OHM, 1%, 0.125W	75042	CEATO-1871F
R534	322-0281-00			RES., FXD, FILM:8.25K OHM, 1%, 0.25W	75042	CEBTO-8251F

Electrical Parts List—7B70 (SN B205000-up)

Ckt No.	Tektronix Part No.	Serial/Model No.		Name & Description	Mfr Code	Mfr Part Number	
		Eff	Dscont				
R535	317-0470-00	XB220000		RES.,FXD,COMP:47 OHM,5%,0.125W	01121	BB4705	
R536	315-0220-00			RES.,FXD,COMP:22 OHM,5%,0.25W	01121	CB2205	
R537	316-0681-00			RES.,FXD,COMP:680 OHM,10%,0.25W	01121	CB6811	
R538	315-0330-00			RES.,FXD,COMP:33 OHM,5%,0.25W	01121	CB3305	
R539	315-0101-00			RES.,FXD,COMP:100 OHM,5%,0.25W	01121	CB1015	
R540	315-0622-00			RES.,FXD,COMP:6.2K OHM,5%,0.25W	01121	CB6225	
R541	315-0131-00			RES.,FXD,COMP:130 OHM,5%,0.25W	01121	CB1315	
R542	321-0260-00			RES.,FXD,FILM:4.99K OHM,1%,0.125W	75042	CEATO-4991F	
R543	315-0114-00			RES.,FXD,COMP:110K OHM,(NOM VALUE),SEL	01121	CB1145	
R544	321-0231-00			RES.,FXD,FILM:2.49K OHM,1%,0.125W	75042	CEATO-2491F	
R545	315-0470-00			RES.,FXD,COMP:47 OHM,5%,0.25W	01121	CB4705	
R546	301-0102-00			RES.,FXD,COMP:1K OHM,5%,0.50W	01121	EB1025	
R547	315-0183-00			RES.,FXD,COMP:18K OHM,5%,0.25W	01121	CB1835	
R548	301-0561-00			RES.,FXD,COMP:560 OHM,5%,0.50W	01121	EB5615	
R549	315-0472-00			RES.,FXD,COMP:4.7K OHM,5%,0.25W	01121	CB4725	
R551	321-0211-00			RES.,FXD,FILM:1.54K OHM,1%,0.125W	75042	CEATO-1541F	
R552	321-0231-00			RES.,FXD,FILM:2.49K OHM,1%,0.125W	75042	CEATO-2491F	
R554	321-0178-00			RES.,FXD,FILM:698 OHM,1%,0.125W	75042	CEATO-6980F	
R556	321-0260-00			RES.,FXD,FILM:4.99K OHM,1%,0.125W	75042	CEATO-4991F	
R557	321-0239-00			RES.,FXD,FILM:3.01K OHM,1%,0.125W	75042	CEATO-3011F	
R558	321-0193-00			RES.,FXD,FILM:1K OHM,1%,0.125W	75042	CEATO-1001F	
R561	315-0820-00			RES.,FXD,COMP:82 OHM,5%,0.25W	01121	CB8205	
R564	321-0207-00			RES.,FXD,FILM:1.4K OHM,1%,0.125W	75042	CEATO-1401F	
R565	321-0189-00			RES.,FXD,FILM:909 OHM,1%,0.125W	75042	CEATO-9090F	
R566	315-0101-00			RES.,FXD,COMP:100 OHM,5%,0.25W	01121	CB1015	
R567	301-0162-00			RES.,FXD,COMP:1.6K OHM,5%,0.50W	01121	EB1625	
R568	315-0470-00			RES.,FXD,COMP:47 OHM,5%,0.25W	01121	CB4705	
R573	321-0295-00			RES.,FXD,FILM:11.5K OHM,1%,0.125W	75042	CEATO-1152F	
R580C	323-0222-00			RES.,FXD,FILM:2K OHM,1%,0.50W	75042	CECTO-2001F	
R581	315-0223-00			RES.,FXD,COMP:22K OHM,5%,0.25W	01121	CB2235	
R582	323-0289-00			RES.,FXD,FILM:10K OHM,1%,0.50W	75042	CECTO-1002F	
R583	315-0104-00			RES.,FXD,COMP:100K OHM,5%,0.25W	01121	CB1045	
R592	315-0101-00			RES.,FXD,COMP:100 OHM,5%,0.25W	01121	CB1015	
R594	322-0273-00			RES.,FXD,FILM:2.05K OHM,1%,0.25W	75042	CEBTO-6811F	
R596	315-0101-00			RES.,FXD,COMP:100 OHM,5%,0.25W	01121	CB1015	
R598	322-0310-00			RES.,FXD,FILM:16.5K OHM,1%,0.25W	75042	CEBTO-1652F	
R599	322-0297-00			RES.,FXD,FILM:12.1K OHM,1%,0.25W	75042	CEBTO-1212F	
R745	315-0220-00			RES.,FXD,COMP:22 OHM,5%,0.25W	01121	CB2205	
R746	321-0260-00			RES.,FXD,FILM:4.99K OHM,1%,0.125W	75042	CEATO-4991F	
R747	315-0220-00			RES.,FXD,COMP:22 OHM,5%,0.25W	01121	CB2205	
R748	315-0114-00			RES.,FXD,COMP:110K OHM,5%,0.25W	01121	CB1145	
R749	321-0285-00			RES.,FXD,FILM:9.09K OHM,1%,0.125W	75042	CEATO-9091F	
R750	321-0289-00			RES.,FXD,FILM:10K OHM,1%,0.125W	75042	CEATO-1002F	
R751	315-0101-00			RES.,FXD,COMP:100 OHM,5%,0.25W	01121	CB1015	
R752	321-0110-00			RES.,FXD,FILM:137 OHM,1%,0.125W	75042	CEATO-1370F	
R755	321-0279-00			RES.,FXD,FILM:7.87K OHM,1%,0.125W	75042	CEATO-7871F	
R765	315-0102-00			RES.,FXD,COMP:1K OHM,5%,0.25W	01121	CB1025	
R766	315-0101-00			RES.,FXD,COMP:100 OHM,5%,0.25W	01121	CB1015	
R767	321-0222-00			RES.,FXD,FILM:2K OHM,1%,0.125W	75042	CEATO-2001F	
R768	315-0472-00			RES.,FXD,COMP:4.7K OHM,5%,0.25W	01121	CB4725	
R775	321-0152-00			RES.,FXD,FILM:374 OHM,1%,0.125W	75042	CEATO-3740F	
R776	321-0204-00			RES.,FXD,FILM:1.3K OHM,1%,0.125W	75042	CEATO-1301F	
R777	321-0191-00			RES.,FXD,FILM:953 OHM,1%,0.125W	75042	CEATO-9530F	

Electrical Parts List—7B70 (SN B205000-up)

Ckt No.	Tektronix Part No.	Serial/Model No. Eff	Dscont	Name & Description	Mfr Code	Mfr Part Number
R780	315-0201-00			RES.,FXD,COMP:200 OHM,5%,0.25W	01121	CB2015
R781	323-0272-00			RES.,FXD,FILM:6.65K OHM,1%,0.50W	75042	CECT0-6651F
R782	321-0735-07			RES.,FXD,FILM:1.001K OHM,0.1%,0.125W	75042	CEAT9-10010B
R783	315-0752-00			RES.,FXD,COMP:7.5K OHM,5%,0.25W	01121	CB7525
R784	321-0228-00			RES.,FXD,FILM:2.32K OHM,1%,0.125W	75042	CEAT0-2321F
R785	311-0597-00			RES.,VAR,NONWIR:50 OHM,20%,0.50W		
R786	321-0088-09			RES.,FXD,FILM:80.6 OHM,1%,0.125W	75042	CEAT9-80R60F
R787	315-0472-00			RES.,FXD,COMP:4.7K OHM,5%,0.25W	01121	CB4725
R788	315-0472-00			RES.,FXD,COMP:4.7K OHM,5%,0.25W	01121	CB4725
R789	315-0472-00			RES.,FXD,COMP:4.7K OHM,5%,0.25W	01121	CB4725
R790	315-0433-00			RES.,FXD,COMP:43K OHM,5%,0.25W	01121	CB4335
R791	323-0272-00			RES.,FXD,FILM:6.65K OHM,1%,0.50W	75042	CECT0-6651F
R793	315-0752-00			RES.,FXD,COMP:7.5K OHM,5%,0.25W	01121	CB7525
R794	321-0228-00			RES.,FXD,FILM:2.32K OHM,1%,0.125W	75042	CEAT0-2321F
R795	311-0541-00			RES.,VAR,NONWIR:20K OHM,20%		
R786	321-0289-00			RES.,FXD,FILM:10K OHM,1%,0.125W	75042	CEAT0-1002F
R797	321-0289-00			RES.,FXD,FILM:10K OHM,1%,0.125W	75042	CEAT0-1002F
R798	315-0510-00			RES.,FXD,COMP:51 OHM,5%,0.25W	01121	CB5105
R799	315-0101-00			RES.,FXD,COMP:100 OHM,5%,0.25W	01121	CB1015
R801	315-0510-00			RES.,FXD,COMP:51 OHM,5%,0.25W	01121	CB5105
R803	315-0470-00			RES.,FXD,COMP:47 OHM,5%,0.25W	01121	CB4705
R804	315-0623-00			RES.,FXD,COMP:62K OHM,5%,0.25W	01121	CB6235
R805	315-0470-00			RES.,FXD,COMP:47 OHM,5%,0.25W	01121	CB4705
R807	315-0101-00			RES.,FXD,COMP:100 OHM,5%,0.25W	01121	CB1015
R809	315-0101-00			RES.,FXD,COMP:100 OHM,5%,0.25W	01121	CB1015
R815	315-0470-00			RES.,FXD,COMP:47 OHM,5%,0.25W	01121	CB4705
R817	315-0910-00			RES.,FXD,COMP:91 OHM,5%,0.25W	01121	CB9105
R819	315-0101-00			RES.,FXD,COMP:100 OHM,5%,0.25W	01121	CB1015
R821	315-0510-00			RES.,FXD,COMP:51 OHM,5%,0.25W	01121	CB5105
U752	156-0077-00			MICROCIRCUIT,LI:SINGLE OPERATIONAL AMPL		
VR573	152-0279-00			SEMICONV DEVICE:ZENER,0.4W,5.1V,5%	07910	1N751A
VR576	152-0326-00			SEMICONV DEVICE:ZENER:0.4W,7.5V,5%		
	670-1145-01			CKT BOARD ASSY:SOURCE	80009	670-1145-01
DS280	150-0048-01			LAMP,INCAND:NO.683,SELECTED	08806	683AS15
S280 ¹	670-1145-01			PUSH BUTTON:SOURCE	80009	670-1145-01
	670-1107-02			CKT BOARD ASSY:MAGNIFIER		
DS780	150-0048-01			LAMP,INCAND:NO.683,SELECTED	08806	683AS15
S780 ¹	670-1107-02			PUSH BUTTON:MAGNIFIER	80009	670-1107-02

¹See Mechanical Parts List for replacement parts.

SECTION 7

DIAGRAMS AND MECHANICAL PARTS ILLUSTRATIONS

Symbols and Reference Designators

Electrical components shown on the diagrams are in the following units unless noted otherwise:

- Capacitors = Values one or greater are in picofarads (pF).
Values less than one are in microfarads (μ F).
Resistors = Ohms (Ω)

Symbols used on the diagrams are based on USA Standard Y32.2-1967.

Logic symbology is based on MIL-STD-806B in terms of positive logic. Logic symbols depict the logic function performed and may differ from the manufacturer's data.

The following special symbols are used on the diagrams:



External Screwdriver adjustment.



External control or connector.



Clockwise control rotation in direction of arrow.



Refer to diagram number indicated in diamond.

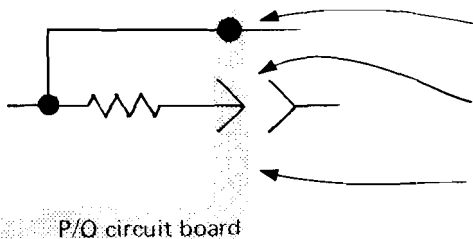

Connection soldered to circuit board.

Connection made to circuit board with interconnecting pin.

Blue tint encloses components located on circuit board.

P/O circuit board

The following prefix letters are used as reference designators to identify components or assemblies on the diagrams.

A	Assembly, separable or repairable (circuit board, etc.)	LR	Inductor/resistor combination
AT	Attenuator, fixed or variable	M	Meter
B	Motor	Q	Transistor or silicon-controlled rectifier
BT	Battery	P	Connector, movable portion
C	Capacitor, fixed or variable	R	Resistor, fixed or variable
CR	Diode, signal or rectifier	RT	Thermistor
DL	Delay line	S	Switch
DS	Indicating device (lamp)	T	Transformer
F	Fuse	TP	Test point
FL	Filter	U	Assembly, inseparable or non-repairable (integrated circuit, etc.)
H	Heat dissipating device (heat sink, heat radiator, etc.)	V	Electron tube
HR	Heater	VR	Voltage regulator (zener diode, etc.)
J	Connector, stationary portion	Y	Crystal
K	Relay		
L	Inductor, fixed or variable		

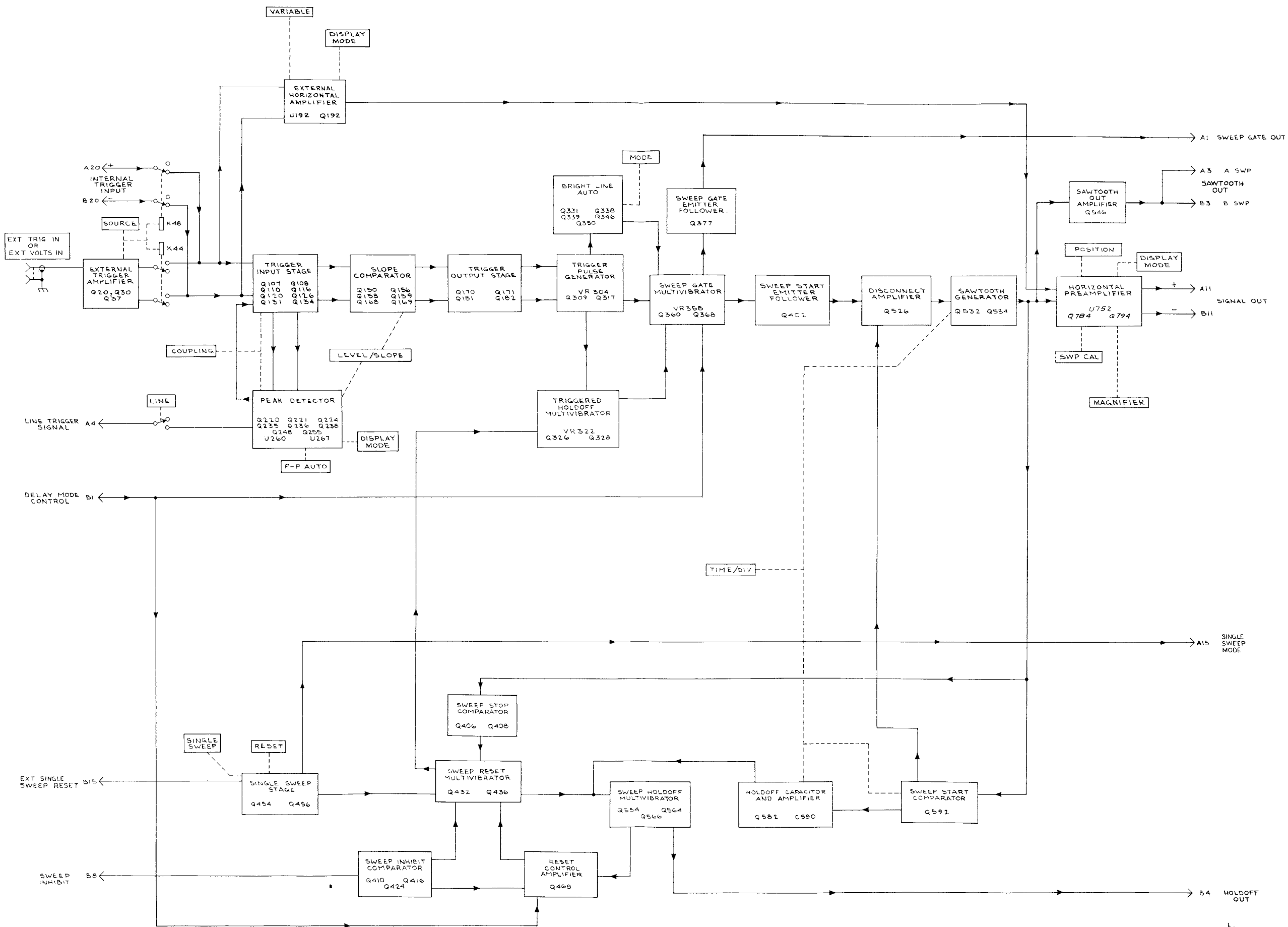

7B70 PLUG-IN

A

BLOCK DIAGRAM
SN B 205000-UP

hg
37.3

VOLTAGE AND WAVEFORM TEST CONDITIONS

Typical voltage measurements were obtained under the following conditions unless noted otherwise on the individual diagrams.

Oscilloscope

Vertical Mode	Left
Horizontal Mode	A
A Intensity	Optimum

7B71 (A Horiz Plug-In)

Level/Slope	Centered on positive slope
Triggering	
Mode	P-P Auto
Coupling	AC
Source	Ext
Magnifier	X1
Time/Div	1 mS
Variable Time/Div	Cal In
B Delay Mode	Independent
Position	Centered

7A16A (Left Vertical Plug-In)

Polarity	+UP
Bandwidth	20 MHz
Volts/Div	1 V
Coupling	AC
Position	Centered

7B70

LEVEL/SLOPE	Centered on positive slope
TRIGGERING	
MODE	P-P AUTO
COUPLING	AC
SOURCE	EXT
MAGNIFIER	X1
TIME/DIV	1 mS
VARIABLE TIME/DIV	CAL IN
DISPLAY MODE	TIME BASE
POSITION	Centered
AMPLIFIER VARIABLE	Fully counterclockwise

The following control settings and connections were changed to obtain waveform photographs.

7B71

Time/Div	As shown on waveforms
----------	-----------------------

7A16A

Volts/Div	As shown on waveforms
-----------	-----------------------

Signal input: A one volt, one kilohertz sine-wave applied to both the 7B70 and 7B71 EXT TRIG IN connector.

All voltages given on the diagrams are in volts. Voltages taken using a Fairchild Model 7050 non-loading digital multimeter. Waveforms shown are actual waveform photographs taken with a Tektronix Oscilloscope Camera System and Projected Graticule. Voltages and waveforms on the diagrams (shown in blue) are not absolute and may vary between instruments because of differing component tolerances, internal calibration or front panel control settings. Readouts are simulated in larger-than-normal type.

VOLTAGE & WAVEFORM CONDITIONS

NOTE
 Vertical deflection factor shown on waveforms does not include attenuation factor of the 10X Probe.

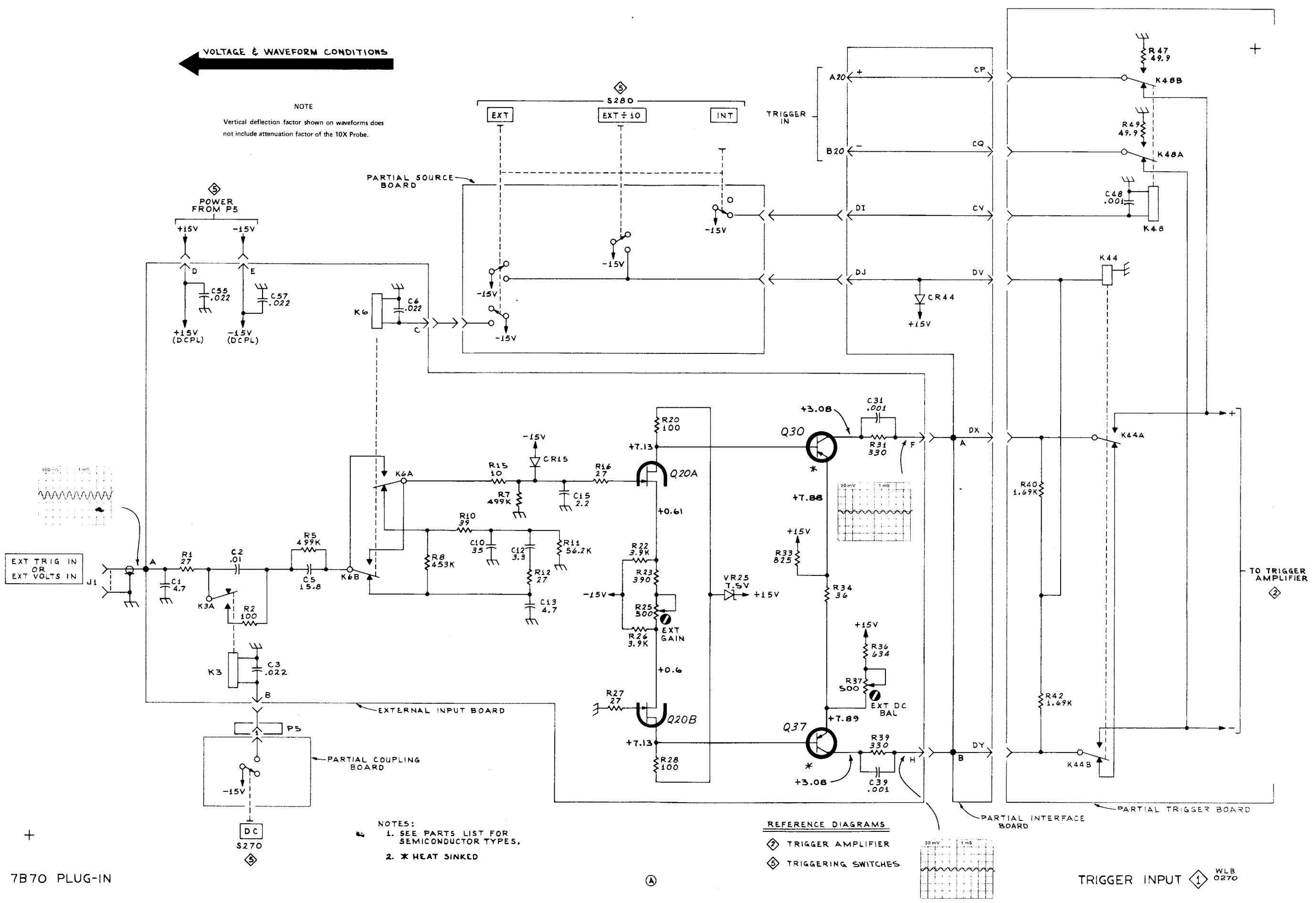

NOTES:
 1. SEE PARTS LIST FOR SEMICONDUCTOR TYPES.
 2. * HEAT SINKED

REFERENCE DIAGRAMS
 TRIGGER AMPLIFIER
 TRIGGERING SWITCHES

7B70 PLUG-IN

TRIGGER INPUT WLB 0270

TRIGGER INPUT

1

2

1

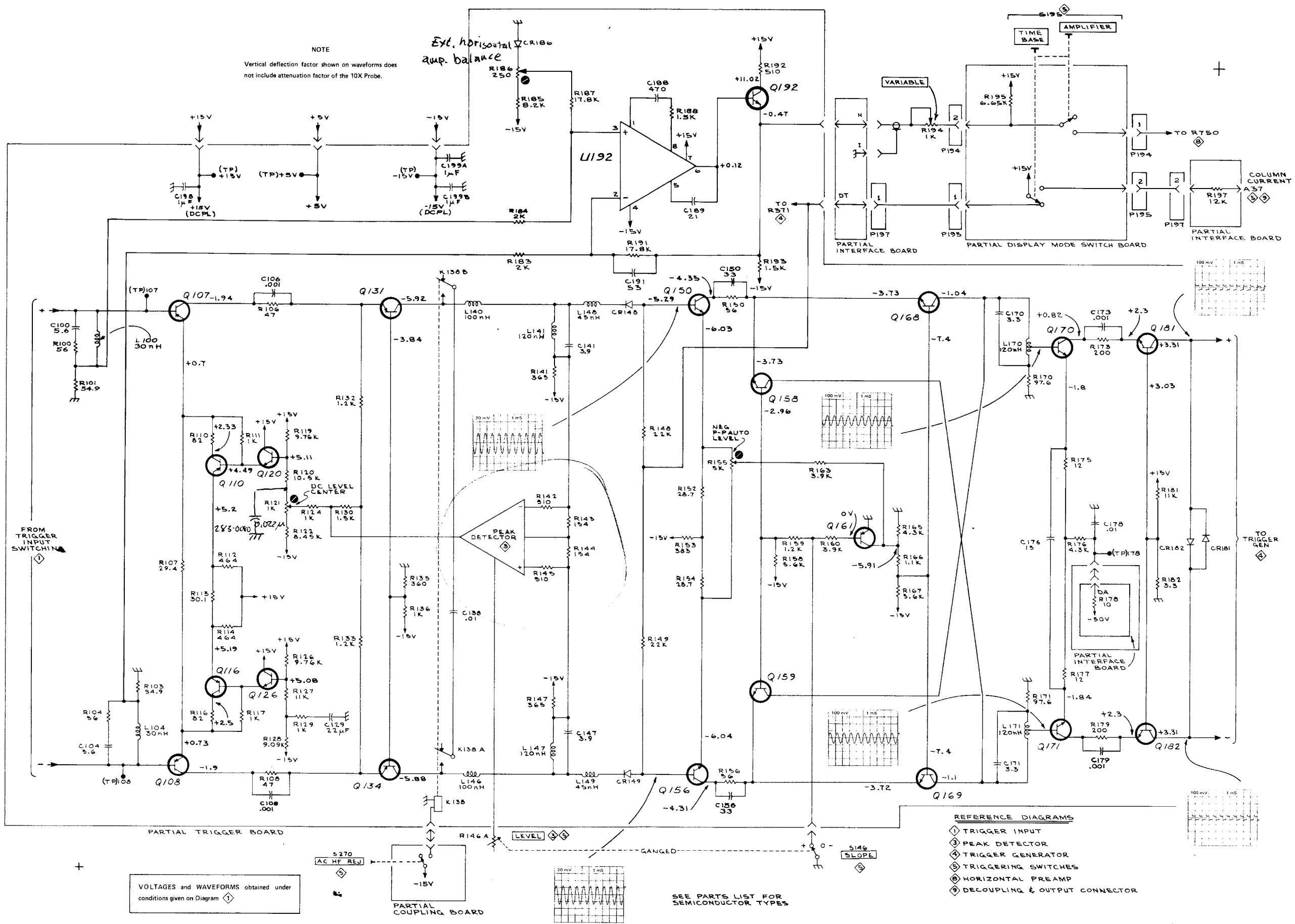

VOLTAGES and WAVEFORMS obtained under conditions given on Diagram

- REFERENCE DIAGRAM
- ① TRIGGER INPUT
 - ② PEAK DETECTOR
 - ③ TRIGGER GENERATOR
 - ④ TRIGGERING SWITCHES
 - ⑤ HORIZONTAL PREAMP
 - ⑥ DECOUPLING & OUTPUT CONNECTOR

TB70 PLUG-IN

TRIGGER AMPLIFIER ②

TRIGGER AMPLIFIER ②

①

hg 0270

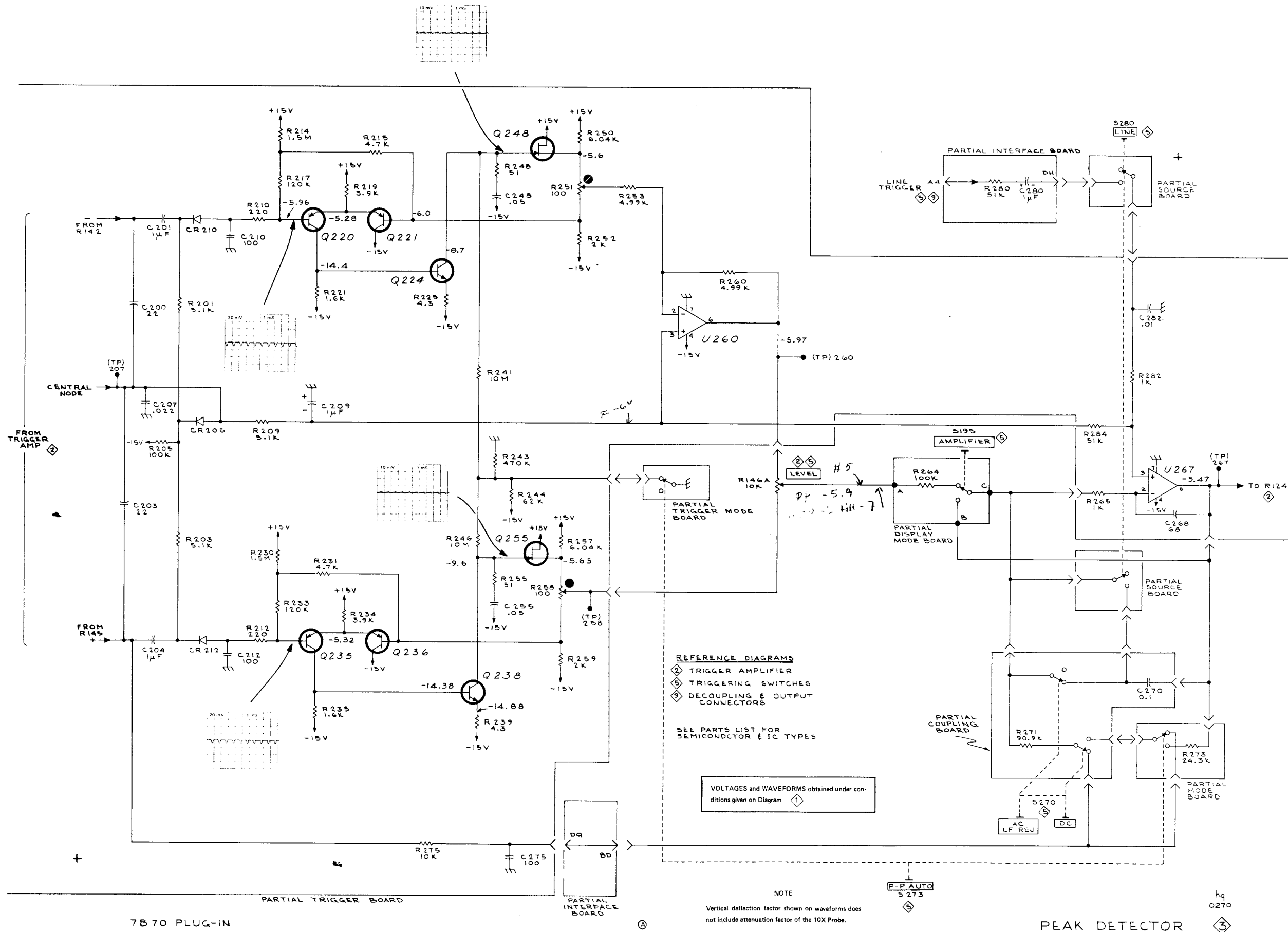

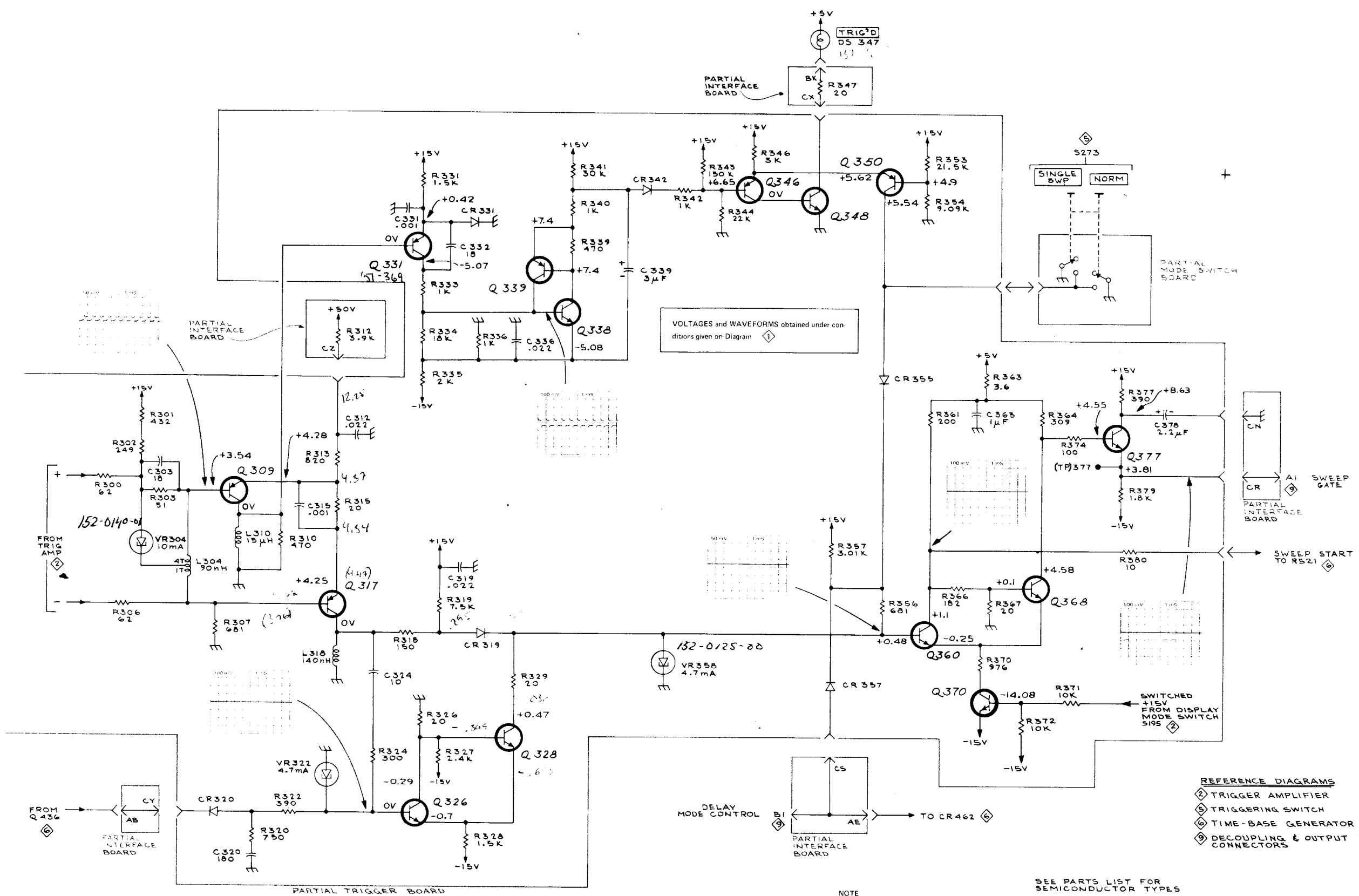

7B70 PLUG-IN

4

TRIGGER GENERATOR

hq
0270

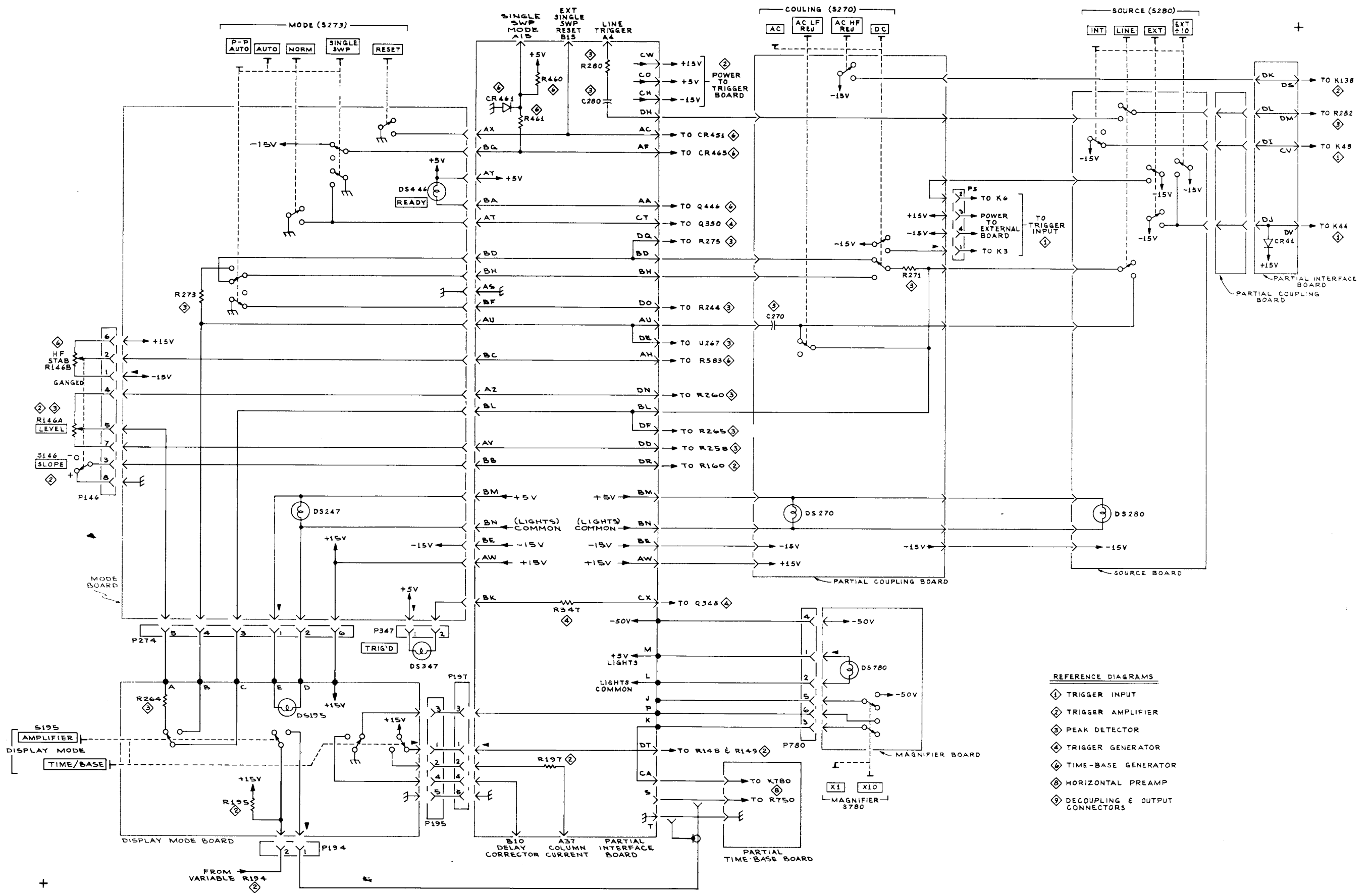

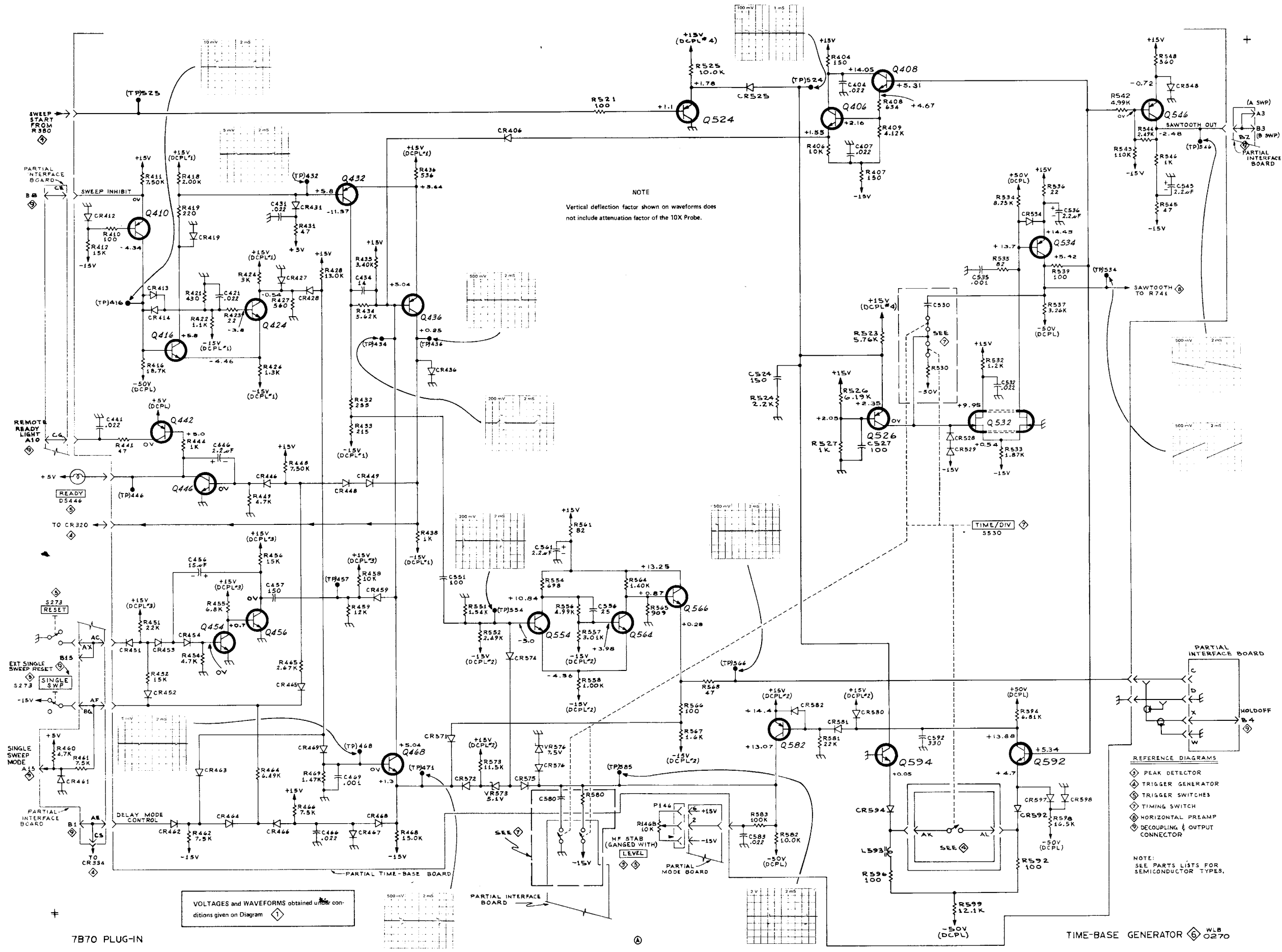

7B70 PLUG-IN

TIME-BASE GENERATOR 6 WLB 0270

TIME-BASE GENERATOR 6

REFERENCE DIAGRAMS
 Ⓢ TIME-BASE GENERATOR
 Ⓢ HORIZONTAL PREAMP
 Ⓢ DECOUPLING & OUTPUT CONNECTOR

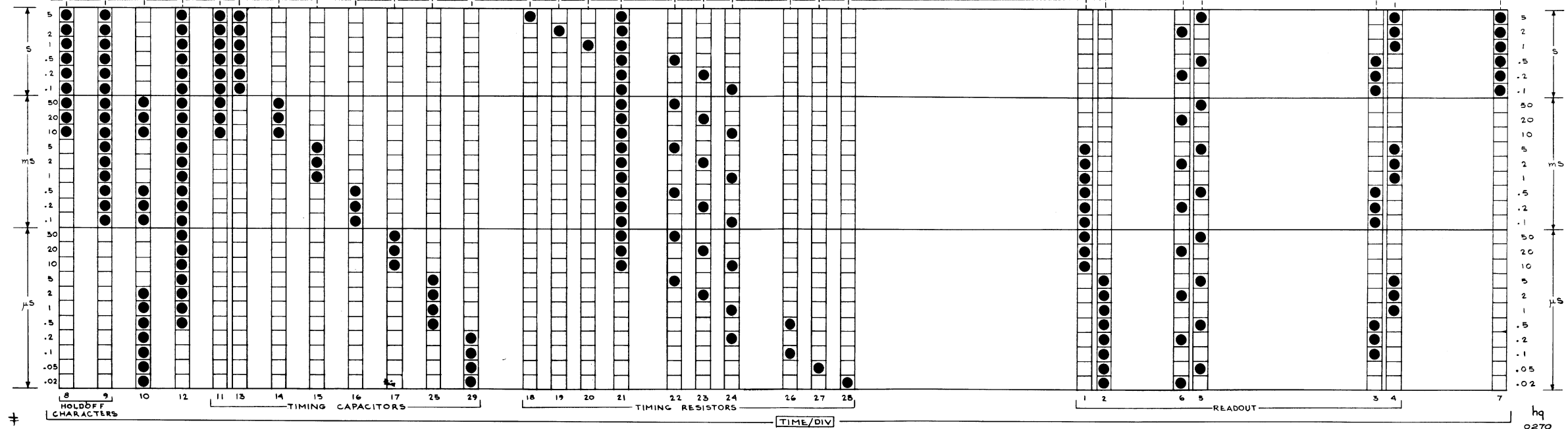
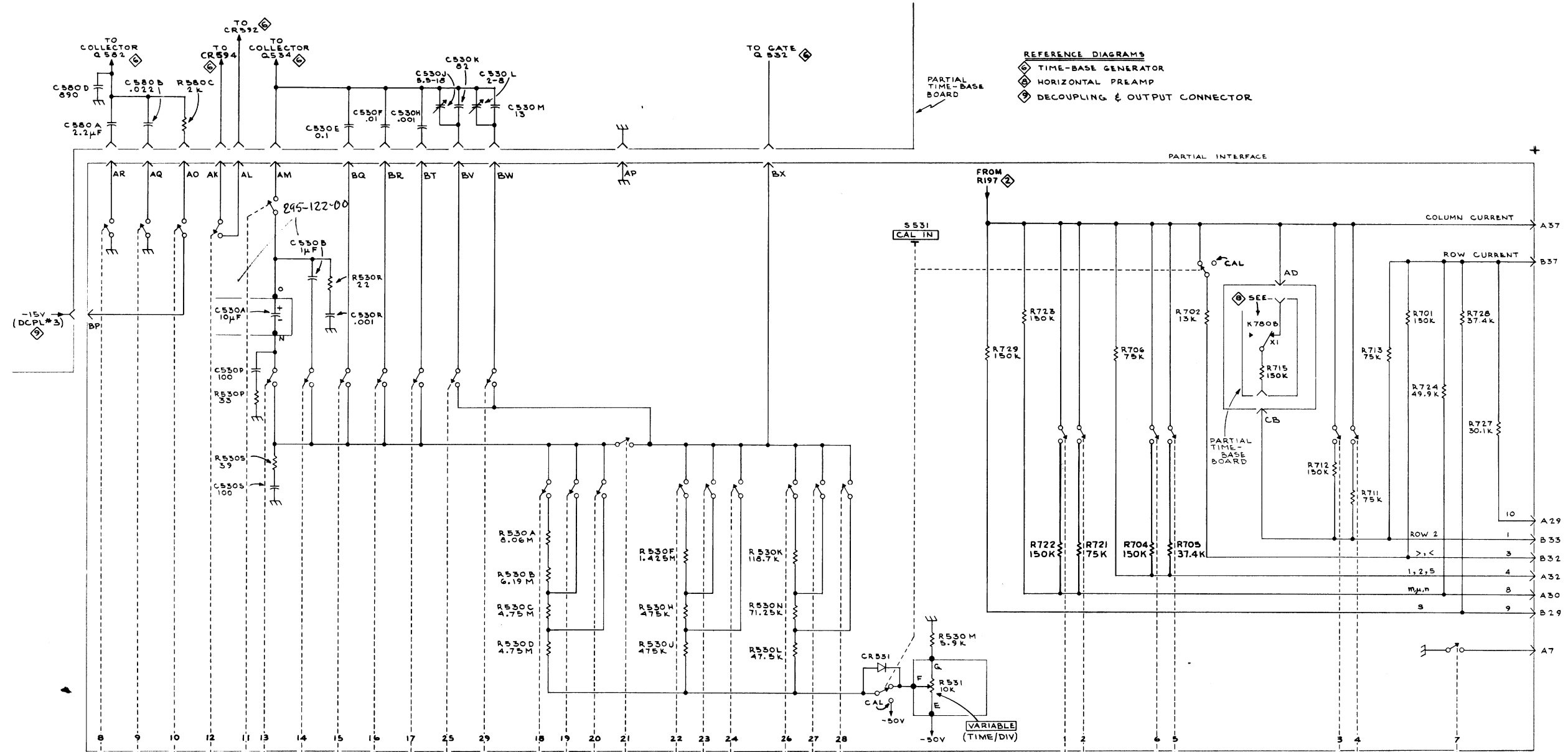

7B70 PLUG-IN

TIMING SWITCH

TIMING SWITCH

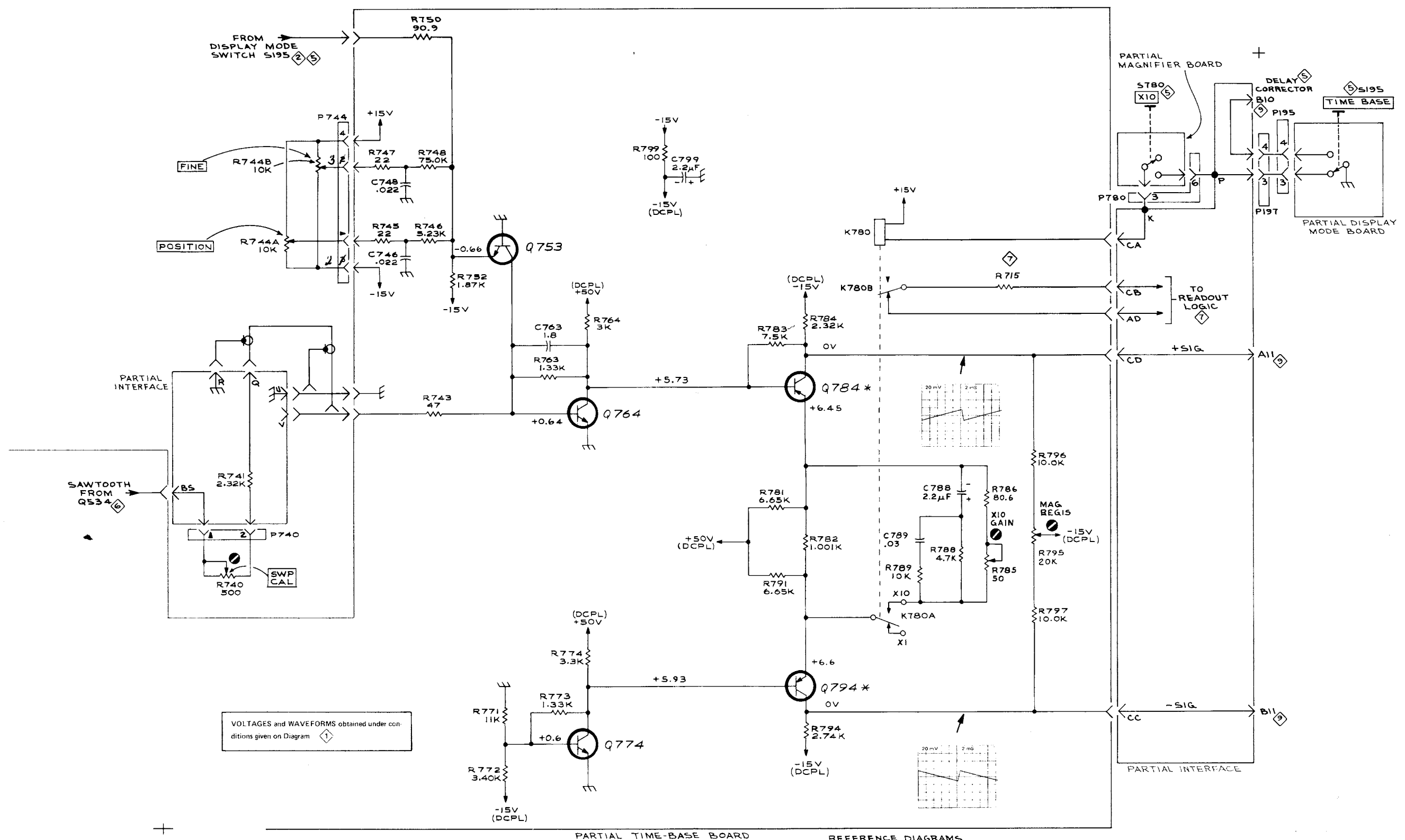

VOLTAGES and WAVEFORMS obtained under conditions given on Diagram 1

NOTE
Vertical deflection factor shown on waveforms does not include attenuation factor of the 10X Probe.

NOTES:
1. SEE PARTS LIST FOR SEMICONDUCTOR TYPES
2. * TRANSISTORS IN SAME TEMP ENVIRONMENT

REFERENCE DIAGRAM
 Ⓢ TRIGGER AMPLIFIER
 Ⓢ TRIGGERING SWITCHES
 Ⓢ TIME-BASE GENERATOR
 Ⓢ TIMING SWITCH
 Ⓢ DECOUPLING & OUTPUT CONNECTOR

VRS 0270

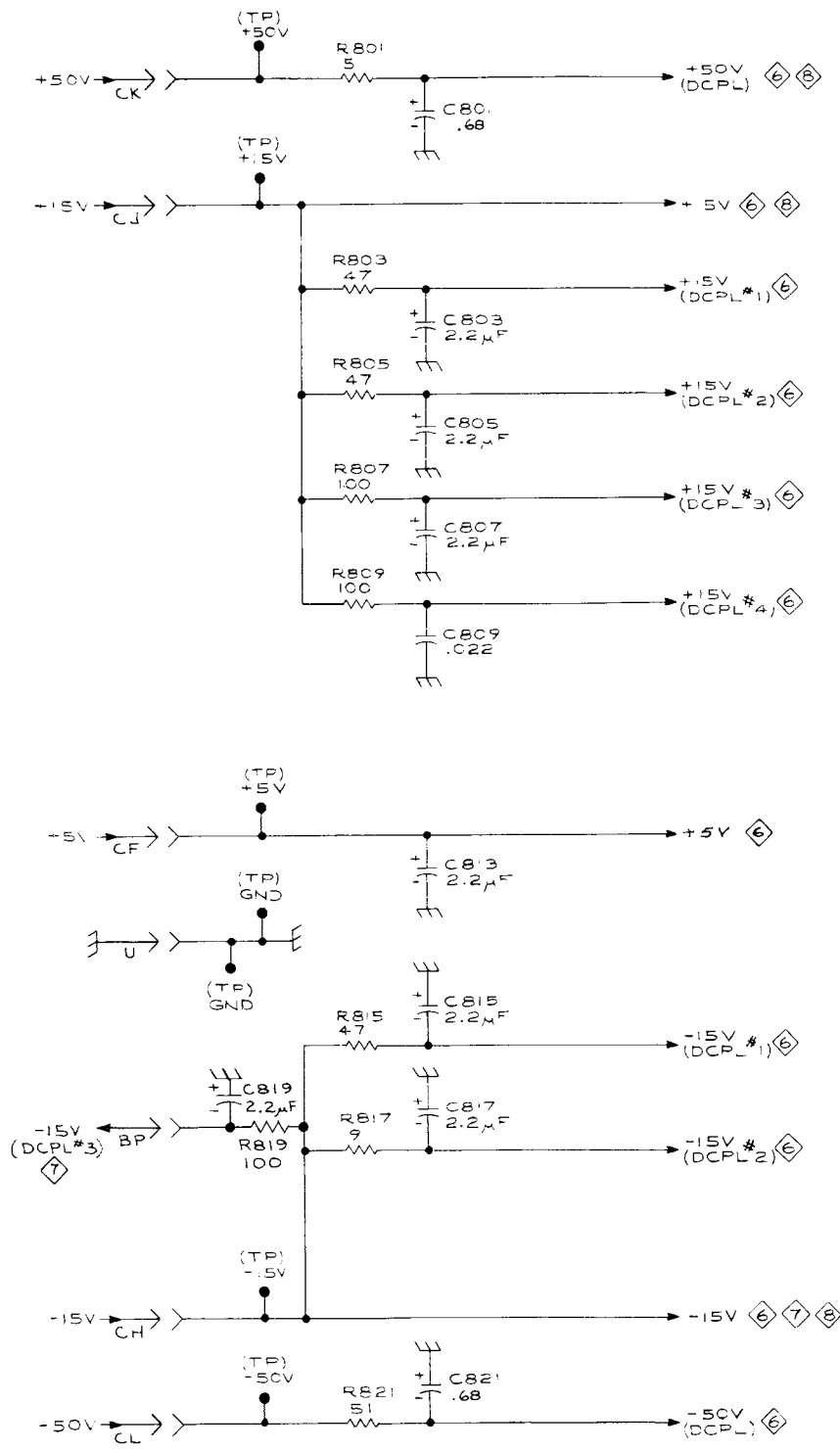

7B70 PLUG-IN

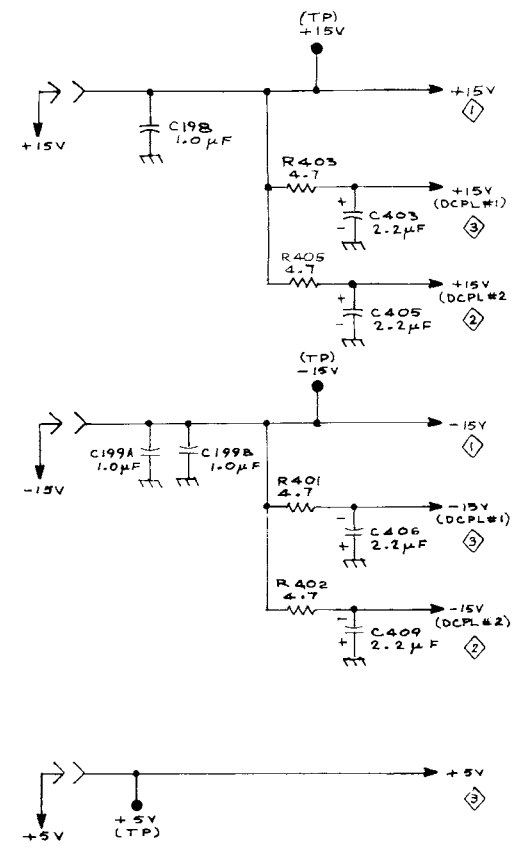

REV. B, OCT. 1974

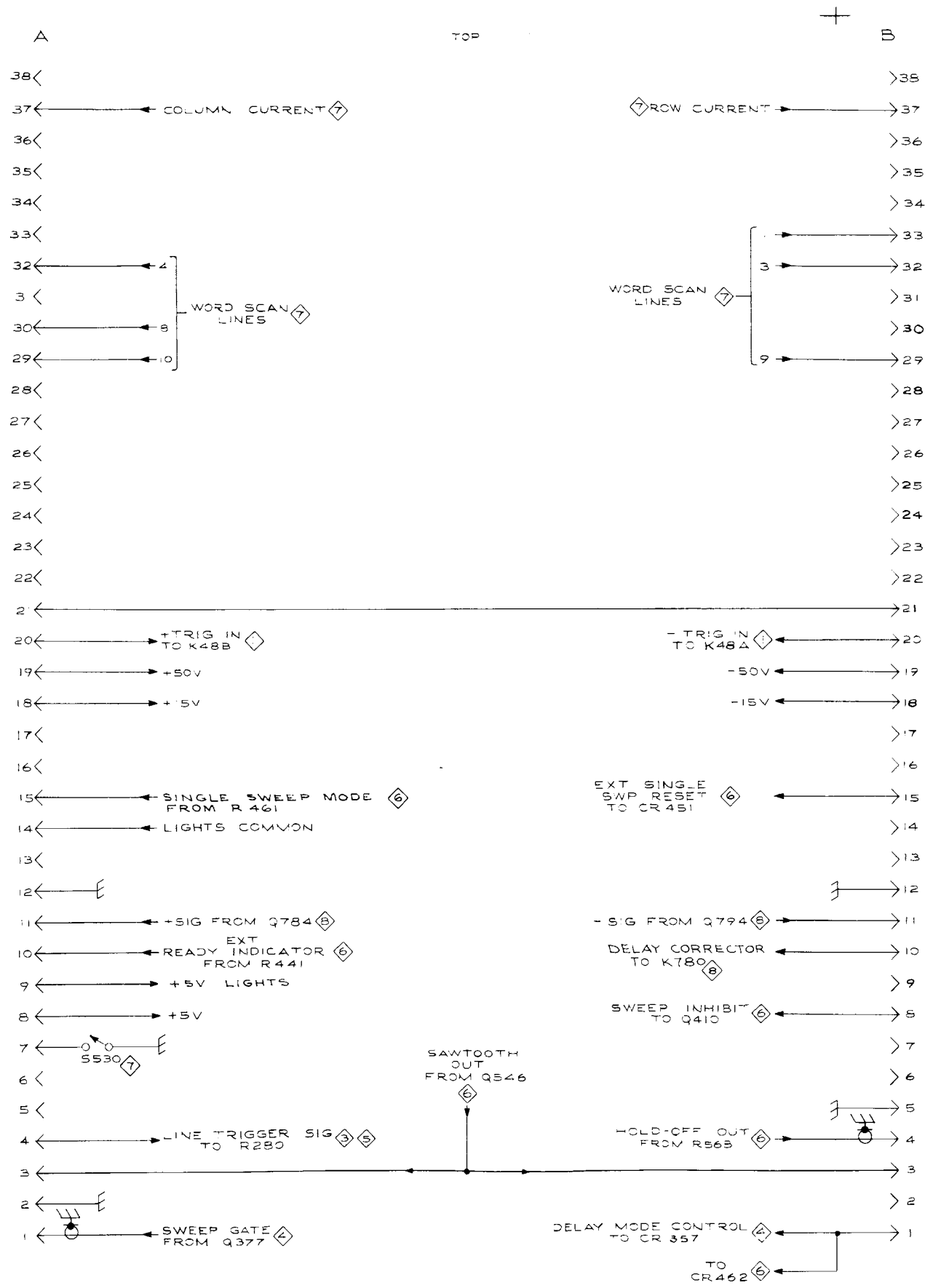

DECOUPLING & OUTPUT CONNECTOR
SN B205000+UP

VRS
273

REPLACEABLE MECHANICAL PARTS

PARTS ORDERING INFORMATION

Replacement parts are available from or through your local Tektronix, Inc. Field Office or representative.

Changes to Tektronix instruments are sometimes made to accommodate improved components as they become available, and to give you the benefit of the latest circuit improvements developed in our engineering department. It is therefore important, when ordering parts, to include the following information in your order: Part number, instrument type or number, serial number, and modification number if applicable.

If a part you have ordered has been replaced with a new or improved part, your local Tektronix, Inc. Field Office or representative will contact you concerning any change in part number.

Change information, if any, is located at the rear of this manual.

SPECIAL NOTES AND SYMBOLS

X000 Part first added at this serial number
00X Part removed after this serial number

FIGURE AND INDEX NUMBERS

Items in this section are referenced by figure and index numbers to the illustrations.

INDENTATION SYSTEM

This mechanical parts list is indented to indicate item relationships. Following is an example of the indentation system used in the description column.

```

1 2 3 4 5           Name & Description
Assembly and/or Component
Attaching parts for Assembly and/or Component
    - - - * - - -
Detail Part of Assembly and/or Component
Attaching parts for Detail Part
    - - - * - - -
Parts of Detail Part
Attaching parts for Parts of Detail Part
    - - - * - - -
  
```

Attaching Parts always appear in the same indentation as the item it mounts, while the detail parts are indented to the right. Indented items are part of, and included with, the next higher indentation. The separation symbol - - - * - - - indicates the end of attaching parts.

Attaching parts must be purchased separately, unless otherwise specified.

ITEM NAME

In the Parts List, an Item Name is separated from the description by a colon (:). Because of space limitations, an Item Name may sometimes appear as incomplete. For further Item Name identification, the U.S. Federal Cataloging Handbook H6-1 can be utilized where possible.

ABBREVIATIONS

#	INCH	ELCTRN	ELECTRON	IN	INCH	SE	SINGLE END
ACTR	NUMBER SIZE	ELEC	ELECTRICAL	INCAND	INCANDESCENT	SECT	SECTION
ADPTR	ACTUATOR	ELCTLT	ELECTROLYTIC	INSUL	INSULATOR	SEMICON	SEMICONDUCTOR
ALIGN	ADAPTER	ELEM	ELEMENT	INTL	INTERNAL	SHLD	SHIELD
AL	ALIGNMENT	EPL	ELECTRICAL PARTS LIST	LPHLDR	LAMPHOLDER	SHLDR	SHOULDERED
ASSEM	ALUMINUM	EQPT	EQUIPMENT	MACH	MACHINE	SKT	SOCKET
ASSY	ASSEMBLED	EXT	EXTERNAL	MECH	MECHANICAL	SL	SLIDE
ATTEN	ASSEMBLY	FIL	FILLISTER HEAD	MTG	MOUNTING	SLFLKG	SELF-LOCKING
AWG	ATTENUATOR	FLEX	FLEXIBLE	NIP	NIPPLE	SLVG	SLEEVING
BD	AMERICAN WIRE GAGE	FLH	FLAT HEAD	NON WIRE	NOT WIRE WOUND	SPR	SPRING
BRKT	BOARD	FLTR	FILTER	OBD	ORDER BY DESCRIPTION	SQ	SQUARE
BRS	BRACKET	FR	FRAME or FRONT	OD	OUTSIDE DIAMETER	SST	STAINLESS STEEL
BRZ	BRASS	FSTNR	FASTENER	OVH	OVAL HEAD	STL	STEEL
BSHG	BRONZE	FT	FOOT	PH BRZ	PHOSPHOR BRONZE	SW	SWITCH
CAB	BUSHING	FXD	FIXED	PL	PLAIN or PLATE	T	TUBE
CAP	CABINET	GSKT	GASKET	PLSTC	PLASTIC	TERM	TERMINAL
CER	CAPACITOR	HDL	HANDLE	PN	PART NUMBER	THD	THREAD
CHAS	CERAMIC	HEX	HEXAGON	PNH	PAN HEAD	THK	THICK
CKT	CHASSIS	HEX HD	HEXAGONAL HEAD	PWR	POWER	TNSN	TENSION
COMP	CIRCUIT	HEX SOC	HEXAGONAL SOCKET	RCPT	RECEPTACLE	TRG	TAPPING
CONN	COMPOSITION	HLCPS	HELICAL COMPRESSION	RES	RESISTOR	TRH	TRUSS HEAD
COV	CONNECTOR	HLEXT	HELICAL EXTENSION	RGD	RIGID	V	VOLTAGE
CPLG	COVER	HV	HIGH VOLTAGE	RLF	RELIEF	VAR	VARIABLE
CRT	COUPLING	IC	INTEGRATED CIRCUIT	RTNR	RETAINER	W/	WITH
DEG	CATHODE RAY TUBE	ID	INSIDE DIAMETER	SCH	SOCKET HEAD	WSHR	WASHER
DWR	DEGREE	IDNT	IDENTIFICATION	SCOPE	OSCILLOSCOPE	XFMR	TRANSFORMER
	DRAWER	IMPLR	IMPELLER	SCR	SCREW	XSTR	TRANSISTOR

CROSS INDEX MFR. CODE NUMBER TO MANUFACTURER

MFR.CODE	MANUFACTURER	ADDRESS	CITY,STATE,ZIP
0000C	Gettig Engineering and Manufacturing Co.		Springmill, PA 16875
00779	AMP, Inc.	P. O. Box 3608	Harrisburg, PA 17105
08261	Spectra-Strip Corp.	7100 Lampson Ave.	Garden Grove, CA 92642
13257	Amerace Ltd.	10 Esna Park Dr.	Markham, Ontario, Canada
22526	Berg Electronics, Inc.	Youk Expressway	New Cumberland, PA 17070
23499	Gavitt Wire and Cable, Division of RSC Industries, Inc.	455 N. Quince St.	Escondido, CA 92025
70276	Allen Mfg. Co.	P. O. Drawer 570	Hartford, CT 06101
71159	Bristol Socket Screw, Div. of American Chain and Cable Co., Inc.	40 Bristol St.	Waterbury, CT 06720
71785	TRW Electronic Components, Cinch Connector Operations	1501 Morse Ave.	Elk Grove Village, IL 60007
73743	Fischer Special Mfg. Co.	446 Morgan St.	Cincinnati, OH 45206
74445	Holo-Krome Co.	31 Brook St. West	Hartford, CT 06110
77250	Pheoll Manufacturing Co., Division of Allied Products Corp.	5700 W. Roosevelt Rd.	Chicago, IL 60650
78189	Illinois Tool Works, Inc. Shakeproof Division	St. Charles Road	Elgin, IL 60120
78471	Tilley Mfg. Co.	900 Industrial Rd.	San Carlos, CA 94070
79136	Waldes, Kohinoor, Inc.	47-16 Austel Place	Long Island City, NY 11101
80009	Tektronix, Inc.	P. O. Box 500	Beaverton, OR 97077
83385	Central Screw Co.	2530 Crescent Dr.	Broadview, IL 60153
83501	Gavitt Wire and Cable, Division of RSC Industries, Inc.	Central St.	Brookfield, MA 01506
87308	N. L. Industries, Inc., Southern Screw Div.	P. O. Box 1360	Statesville, NC 28677

Mechanical Parts List—7B70 (SN B205000-up)

Fig. & Index No.	Tektronix Part No.	Serial/Model No. Eff	No. Dscont	Qty	1	2	3	4	5	Name & Description	Mfr Code	Mfr Part Number
1-1	366-1064-00			1						KNOB:GRAY--LEVEL/SLOPE		
	213-0153-00			1						. SETSCREW:5-40 X 0.125 INCH,HEX SOC STL	74445	OBD
-2	354-0342-00			1						RING:KNOB SKIRT		
	311-0972-00			1						RESISTOR,VARIABLE:		
-3	-----			1						. RESISTOR,VARIABLE:(SEE R146,S146 EPL)		
-4	214-1235-00			1						. DRIVE:URNS REDUCTION		
										(ATTACHING PARTS)		
	210-0978-00			1						WASHER,FLAT:0.375 ID X 0.50 INCH OD,STL	78471	OBD
-5	210-0590-00			1						NUT,PLAIN,HEX.:0.375 X 0.438 INCH,STL	73743	2X28269-402
										-----*		
-6	366-1077-00			1						KNOB:GRAY--POSITION	80009	366-1077-00
	213-0153-00			1						. SETSCREW:5-40 X 0.125 INCH,HEX SOC STL	74445	OBD
-7	366-1319-00			1						KNOB:GRAY--FINE	80009	366-1319-00
	213-0725-00			1						. SETSCREW:3.048 X 0.094 INCH,HEX SOC STL	71159	OBD
-8	-----			1						RESISTOR,VAR:		
										(ATTACHING PARTS)		
-9	210-0465-00			1						NUT,PLAIN,HEX.:0.25-32 X 0.375 INCH BRS	73743	3095-402
-10	210-0583-00			1						NUT,PLAIN,HEX.:0.25-32 X 0.312 INCH,BRS	73743	2X20319-402
										-----*		
-11	-----			1						RESISTOR,VAR:		
										(ATTACHING PARTS)		
-12	220-0420-00			1						NUT:ADAPTER,0.50 INCH HEX		
										-----*		
-13	670-1139-04			1						CKT BOARD ASSY:DISPLAY MODE		
	380-0153-01			1						. HOUSING,LIGHT:		
										(ATTACHING PARTS)		
	213-0181-00			1						. SCREW:THREAD FORMING,#2 X 0.375 INCH,PHS		
										-----*		
	131-0589-00			7						. CONTACT,ELEC:0.46 INCH LONG	22526	47350
										(ATTACHING PARTS)		
-14	211-0156-00			1						SCREW,MACHINE:1-72 X 0.25",82 DEG,FLH STL	77250	OBD
										-----*		
-15	352-0157-00			1						LAMPHOLDER:WHITE PLASTIC	80009	352-0157-00
-16	378-0602-00			1						LENS,LIGHT:GREEN	80009	378-0602-00
-17	200-0935-00			1						BASE,LAMPHOLDER:0.29 OD X 0.19 CASE	80009	200-0935-00
-18	670-1140-02			1						CKT BOARD ASSY:MODE (TRIGGERING)		
	380-0156-03			1						. HOUSING,LIGHT:		
										(ATTACHING PARTS)		
	213-0181-00			1						. SCREW,THREAD FORMING,#2 X 0.375 INCH,PHS		
										-----*		
-19	136-0263-03			20						. CONTACT,ELEC:FOR 0.025 INCH SQUARE PIN	00779	86250-2
-20	131-0608-00			18						. CONTACT,ELEC:0.365 INCH LONG	22526	47357
-21	386-1635-00			2						. SUPPORT:CKT BOARD,FOR 0.188 INCH BOARD H		
										(ATTACHING PARTS)		
-22	211-0156-00			2						SCREW,MACHINE:1-72 X 0.25",82 DEG,FLH STL	77250	OBD
										-----*		
-23	670-1146-01			1						CKT BOARD ASSY:COUPLING (TRIGGERING)		
-24	386-1557-00			2						. SPACER,CKT BD:PLASTIC	80009	386-1557-00
	380-0155-02			1						. HOUSING,LIGHT:		
										(ATTACHING PARTS)		
	213-0181-00			1						. SCREW:THREAD FORMING,#2 X 0.375 INCH,PHS		
										-----*		
-25	131-0608-00			4						. CONTACT,ELEC:0.365 INCH LONG	22526	47357
-26	136-0327-00			13						. SOCKET:PIN TERMINAL		
-27	131-0590-00			86						. CONTACT,ELEC:0.71 INCH LONG	22526	47351
										(ATTACHING PARTS)		
-28	211-0156-00			2						SCREW,MACHINE:1-72 X 0.25",82 DEG,FLH STL	77250	OBD
										-----*		
-29	670-1145-01			1						CKT BOARD ASSY:SOURCE (TRIGGERING)		
-30	386-1559-00			2						. SPACER,CKT BD:PLASTIC	80009	386-1559-00
	380-0155-02			1						. HOUSING,LIGHT:		
										(ATTACHING PARTS)		
	213-0181-00			1						. SCREW:THREAD FORMING,#2 X 0.375 INCH,PHS		
										-----*		

Mechanical Parts List—7B70 (SN B205000-up)

Fig. & Index No.	Tektronix Part No.	Serial/Model No. Eff Dscont	Qty	1 2 3 4 5					Name & Description	Mfr Code	Mfr Part Number
1-31	136-0327-01		10	.					CONTACT,ELEC:0.067 INCH DIA (ATTACHING PARTS)	00779	86281-2
-32	211-0156-00		2	SCREW,MACHINE:1-72 X 0.25",82 DEG,FLH STL						77250	OBD
-33	670-1107-02		1	CKT BOARD ASSY:MAGNIFIER							
	380-0148-01		1	. HOUSING,LIGHT:					(ATTACHING PARTS)		
	213-0181-00		1	. SCREW:THREAD FORMING,#2 X 0.375 INCH,PHS							
-34	131-0589-00		6	. CONTACT,ELEC:0.46 INCH LONG (ATTACHING PARTS)						22526	47350
-35	211-0156-00		1	SCREW,MACHINE:1-72 X 0.25",82 DEG,FLH STL						77250	OBD
-36	366-1189-00		1	KNOB:GRAY--VARIABLE							
	213-0153-00		1	. SETSCREW:5-40 X 0.125 INCH,HEX SOC STL						74445	OBD
-37	-----		1	RESISTOR,VARIABLE:					(ATTACHING PARTS)		
-38	210-0583-00		2	NUT,PLAIN,HEX.:0.25-32 X 0.312 INCH,BRS						73743	2X20319-402
-39	-----		1	RESISTOR,VAR:					(ATTACHING PARTS)		
	210-0046-00		2	WASHER,LOCK:INTL,0.26 ID X 0.40" OD,STL						78189	1214-05-00-0541C
-40	129-0252-00		1	POST,METALLIC:0.45 X 0.312 HEX							
-41	358-0409-00		1	BSHG,MACH. THD:0.25-32 X 0.159 ID X 0.24						80009	358-0409-00
-42	358-0301-02		1	BUSHING,SLEEVE:GRAY PLASTIC						80009	358-0301-02
-43	131-0106-01		1	CONNECTOR:COAXIAL,1 CONTACT,BNC,FEMALE							
-44	366-1103-00		1	KNOB:GRAY--TIME/DIV							
	213-0020-00		2	. SETSCREW:6-32 X 0.125 INCH,HEX.SOC STL						70276	OBD
-45	366-1166-00		1	KNOB:RED--VARIABLE (CAL IN)							
	213-0153-00		1	. SETSCREW:5-40 X 0.125 INCH,HEX SOC STL						74445	OBD
-46	384-0490-00		1	SHAFT,EXTENSION:5.93 INCHES LONG							
-47	670-1137-03		1	CKT BOARD ASSY:INTERFACE							
	105-0411-00		1	. ACTUATOR ASSY:							
-48	200-0963-00		1	. . COVER:CAM SWITCH							
-49	211-0022-00		4	. . SCREW,MACHINE:2-56 X 0.188 INCH,PNH STL						83385	OBD
-50	210-0405-00		4	. . NUT,PLAIN,HEX.:2-56 X 0.188 INCH,BRS						73743	2X12157-402
-51	210-0001-00		4	. . WASHER,LOCK:INTL,0.092 ID X 0.18"OD,STL						78189	1202-00-00-0541C
-52	354-0219-00		1	. . RING,RETAINING:FOR 0.25 INCH SHAFT						79136	5103-25-MD-R
-53	214-1127-00		1	. . ROLLER,DETENT:0.125 DIA X 0.125 INCH L						80009	214-1127-00
-54	214-1139-00 ¹		-	. . SPRING,FLAT:GOLD COLORED						80009	214-1139-00
	214-1139-02 ¹		-	. . SPRING,FLAT:GREEN COLORED						80009	214-1139-02
	214-1139-03 ¹		-	. . SPRING,FLAT:RED COLORED						80009	214-1139-03
-55	407-0653-00		1	. . BRACKET:SUPPORT							
-56	105-0122-00		1	. . DRUM ASSEMBLY--TIME/DIV							
-57	401-0057-00		1	. . BEARING,CAM SW:FRONT						80009	401-0057-00
-58	401-0056-00		1	. . BEARING,CAM SW:REAR						80009	401-0056-00
-59	210-0406-00		6	. . NUT,PLAIN,HEX.:4-40 X 0.188 INCH,BRS (ATTACHING PARTS)						73743	2X12161-402
-60	211-0116-00		6	. SCR,ASSEM WSHR:4-40 X 0.312 INCH,PNH BRS (ATTACHING PARTS)						83385	OBD
-61	351-0180-00		1	. SLIDE,GUIDE:SWITCH ACTUATOR						80009	351-0180-00
-62	214-1136-00		1	. SLIDE:ACTUATOR							
-63	131-0566-00		22	. LINK,TERM.CONNE:0.086 DIA X 2.375 INCH L						0000C	L-2007-1
-64	131-0593-00		9	. CONTACT,ELEC:1.15 INCH LONG						22526	47354
-65	131-0590-00		77	. CONTACT,ELEC:0.71 INCH LONG						22526	47351
-66	131-0608-00		10	. CONTACT,ELEC:0.365 INCH LONG						22526	47357
	131-0665-00		1	. CONTACT,ELEC:0.88 INCH LONG						22526	47358
-67	351-0155-00		8	. GUIDE:TERMINAL LEAD							
-68	351-0185-00		4	. GUIDE-POST,LOCK:0.65 INCH LONG						80009	351-0185-00
-69	351-0183-00		6	. GUIDE-POST,LOCK: (ATTACHING PARTS)							
-70	220-0547-01		5	NUT,BLOCK:0.38 X 0.25 X 0.282"OA						80009	220-0547-01
-71	211-0116-00		5	SCR,ASSEM WSHR:4-40 X 0.312 INCH,PNH BRS						83385	OBD
-72	211-0105-00		5	SCREW,MACHINE:4-40 X 0.188"100 DEG,FLH STL (ATTACHING PARTS)						83385	OBD

¹Replace only with part bearing the same color code as the original part in your instrument.

Mechanical Parts List—7B70 (SN B205000-up)

Fig. & Index No.	Tektronix Part No.	Serial/Model No. Eff	No. Dscont	Qty	1 2 3 4 5	Name & Description	Mfr Code	Mfr Part Number
-73	348-0067-00			1		GROMMET,PLASTIC:0.312 INCH DIA	80009	348-0067-00
-74	670-1138-04			1		CKT BOARD ASSY:TIME BASE	80009	670-1138-04
-75	214-0579-00			22		. TERM.,TEXT PT:0.40 INCH LONG	80009	214-0579-00
-76	136-0337-00			1		. SOCKET,RELAY:8 PIN		
-77	136-0220-00			25		. SOCKET,PLUG-IN:3 PIN	71785	133-23-11-034
-78	136-0235-00			2		. SOCKET,PLUG-IN:6 CONTACT,ROUND	71785	133-96-12-062
	136-0237-00			1		. SOCKET,PLUG-IN:8 CONTACT,ROUND	71785	133-98-12-062
-79	136-0263-03			37		. CONTACT,ELEC:FOR 0.025 INCH SQUARE PIN	00779	86250-2
-80	131-0608-00			4		. CONTACT,ELEC:0.365 INCH LONG	22526	47357
	200-0945-00			1		. COVER,HALF XSTR:FOR DUAL TO-18 CASE	80009	200-0945-00
	200-0945-01			1		. COVER,HALF XSTR:FOR DUAL TO-18 CS,2-56 THD	80009	200-0945-01
	211-0062-00			1		. SCREW,MACHINE:2-56 X 0.312 INCH,RDH STL	83385	OBD
-81	211-0155-00			5		. SCREW,EXT,RLV B:4-40 X 0.375 INCH,SST	80009	211-0155-00
-82	361-0238-00			5		. SPACER,SLEEVE:0.25 OD X 0.34 INCH LONG	80009	361-0238-00
-83	388-1431-00			1		CIRCUIT BOARD:SHIELD(TRIGGERING)		
	388-1639-00			1		CIRCUIT BOARD:SHIELD(TIMEBASE,NOT SHOWN)		
-84	670-1136-05			1		CKT BOARD ASSY:TRIGGER	80009	670-1136-05
	200-0945-00			2		. COVER,HALF XSTR:FOR DUAL TO-18 CASE	80009	200-0945-00
	200-0945-01			2		. COVER,HALF XSTR:FOR DUAL TO-18 CS,2-56 THD	80009	200-0945-01
-85	136-0220-00			8		. SOCKET,PLUG-IN:3 PIN	71785	133-23-11-034
-86	136-0337-00			3		. SOCKET,RELAY:8 PIN		
-87	136-0237-00			3		. SOCKET,PLUG-IN:8 CONTACT,ROUND	71785	133-98-12-062
-88	136-0263-03			26		. CONTACT,ELEC:FOR 0.025 INCH SQUARE PIN	00779	86250-2
-89	136-0350-00			33		. SOCKET,TRANSISTOR:3 PIN		
-90	214-0579-00			11		. TERM.,TEST PT:0.40 INCH LONG	80009	214-0579-00
-91	211-0155-00			5		. SCREW,EXT,RLV B:4-40 X 0.375 INCH,SST	80009	211-0155-00
-92	361-0238-00			5		. SPACER,SLEEVE:0.25 OD X 0.34 INCH LONG	80009	361-0238-00
-93	214-1140-00			10		SPRING,HLCPS:0.251 OD X 0.375"L,SST WIRE	80009	214-1140-00
	131-0937-00			2		TERMINAL LUG:(NOT SHOWN)		
-94	348-0235-00			2		SHLD GSKT,ELEC:4.734 INCH LONG	80009	348-0235-00
-95	670-1144-00			1		CKT BOARD ASSY:EXTERNAL INPUT	80009	670-1144-00
-96	337-1270-00			1		. SHIELD:		
-97	131-0608-00			6		. CONTACT,ELEC:0.365 INCH LONG	22526	47357
-98	136-0252-01			6		. CONTACT,ELEC:0.178 INCH LONG	00779	1-332095-2
	136-0252-04	B205000	B226349	25		. CONTACT,ELEC:0.188 INCH LONG	22526	75060
	136-0336-00	B226350		1		. SOCKET,PLUG-IN:5 PIN	80009	136-0336-00
	136-0337-00	B226350		1		. SOCKET,RELAY:8 PIN	80009	136-0337-00
	136-0366-00	B226350		1		. SOCKET,PLUG-IN:6 PIN	80009	136-0366-00
	136-0350-00	B226350		2		. SOCKET,PLUG-IN:3 PIN	80009	136-0350-00
						(ATTACHING PARTS)		
-99	131-0907-00			1		CONTACT:ELECTRICAL GROUND		
-100	407-0748-00			1		BRACKET:		
						- - - * - - -		
-101	344-0131-00			1		CLIP,SPG TENS:CIRCUIT BOARDMOUNTING	80009	344-0131-00
-102	211-0116-00			1		SCR,ASSEM WSHR:4-40 X 0.312 INCH,PNH BRS	83385	OBD
	210-0406-00			1		NUT,PLAIN,HEX.:4-40 X 0.188 INCH,BRS	73743	2X12161-402
-103	352-0213-00			1		HOLDER,CABLE:FOR 0.16 X 0.08"CABLE,PLASTIC	80009	352-0213-00
-104	386-1657-00			8		SUPPORT:CKT BOARD,FOR 0.185 INCH BOARD H		
-105	131-0664-00			1		CONTACT,ELEC:SHAFT GROUND		
						(ATTACHING PARTS)		
-106	211-0101-00			1		SCREW,MACHINE:4-40 X 0.25" 100 DEG,FLH STL	83385	OBD
	210-0586-00			1		NUT,PLAIN,EXT W:4-40 X 0.25 INCH,STL	78189	OBD
						- - - * - - -		
-107	366-1058-10			1		KNOB:LATCH		
-108	214-1095-00			1		PIN,SPG,SPLIT:0.094 OD X 0.187 INCH LONG	13257	52-022-094-0187
-109	105-0076-00			1		REL BAR,LATCH:PLUG-IN UNIT	80009	105-0076-00
-110	214-1280-00			1		SPRING,HLCPS:0.14 OD X 1.126"L,0.16"DIA W	80009	214-1280-00
-111	105-0075-00			1		PAWL:0.475 X 0.21 X 0.184 INCH,PLSTC	80009	105-0075-00
-112	214-1054-00			1		SPRING,DETENT:LATCH	80009	214-1054-00
-113	333-1260-00			1		PANEL,FRONT:		
-114	386-1447-13			1		SUBPANEL,FRONT:		
-115	386-1402-00			1		PANEL,REAR:	80009	386-1402-00
-116	214-1061-00			1		SPRING,GROUND:FLAT	80009	214-1061-00
-117	426-0505-04			1		FR SECT,PLUG-IN:TOP	80009	426-0505-04
-118	426-0499-04			1		FR SECT:BOTTOM		

Mechanical Parts List—7B70 (SN B205000-up)

Fig. & Index No.	Tektronix Part No.	Serial/Model No. Eff Dscont	Qty	1 2 3 4 5					Name & Description	Mfr Code	Mfr Part Number
1-119	213-0192-00		8						SCR,TPG,THD FOR:6-32 X 0.50 INCH,PNH STL	87308	OBD
	361-0326-04		1						SPACER,SLEEVE:0.10 INCH LONG		
-120	337-1064-04		2						SHIELD,ELEC:SIDE	80009	337-1064-00
-121	214-1190-00		1						EXTENDER,RETR:KNOB		
-122	407-0553-00		1						BRKT,CMPNT MTG:	80009	407-0553-00
	361-0326-00		1						SPACER,SLEEVE:0.18 ID X 0.25 OD X 0.10"L (ATTACHING PARTS)	80009	361-0326-00
-124	210-0583-00		1						NUT,PLAIN,HEX.:0.25-32 X 0.312 INCH,BRS - - - * - - -	73743	2X20319-402
-125	344-0244-00		2						CLIP:COMPONENT MOUNTING (ATTACHING PARTS FOR EACH)		
	361-0007-00		1						SPACER,SLEEVE:0.250 INCH DIA,PLASTIC - - - * - - -	80009	361-0007-00
-126	175-0825-00		FT						WIRE,ELECTRICAL:2 WIRE RIBBON	23499	TEK-175-0825-00
-127	175-0827-00		FT						WIRE,ELECTRICAL:4 WIRE RIBBON	08261	TEK-175-0827-00
-128	175-0828-00		FT						WIRE,ELECTRICAL:5 WIRE RIBBON	23499	TEK-175-0828-00
-129	175-0829-00		FT						WIRE,ELECTRICAL:6 WIRE RIBBON	83501	TEK-175-0829-00
-130	175-0831-00		FT						WIRE,ELECTRICAL:8 WIRE RIBBON	08261	TEK-175-0831-00
-131	352-0171-00		6						HOLDER,TERM.CON:1 WIRE BLACK	80009	352-0171-00
-132	352-0169-00		3						HOLDER,TERM.CON:2 WIRE BLACK	80009	352-0169-00
-133	352-0162-00		2						HOLDER,TERM.CON:4 WIRE BLACK	80009	352-0162-00
-134	352-0163-00		2						HOLDER,TERM.CON:5 WIRE BLACK	80009	352-0163-00
-135	352-0164-00		1						HOLDER,TERM.CON:6 WIRE BLACK	80009	352-0164-00
-136	352-0166-00		1						HOLDER,TERM.CON:8 WIRE BLACK	80009	352-0166-00
-137	131-0707-00		43						CONTACT,ELEC:0.48"L,22-26 AWG WIRE	22526	47439
	131-0708-00		1						CONTACT,ELEC:0.48"L,28-32 AWG WIRE	22526	47437
	131-0755-00		6						CONNECTOR,TERM:(FOR SMALL WIRE)		
-138	131-0512-00		6						CONNECTOR,TERM:COAXIAL CABLE		

+

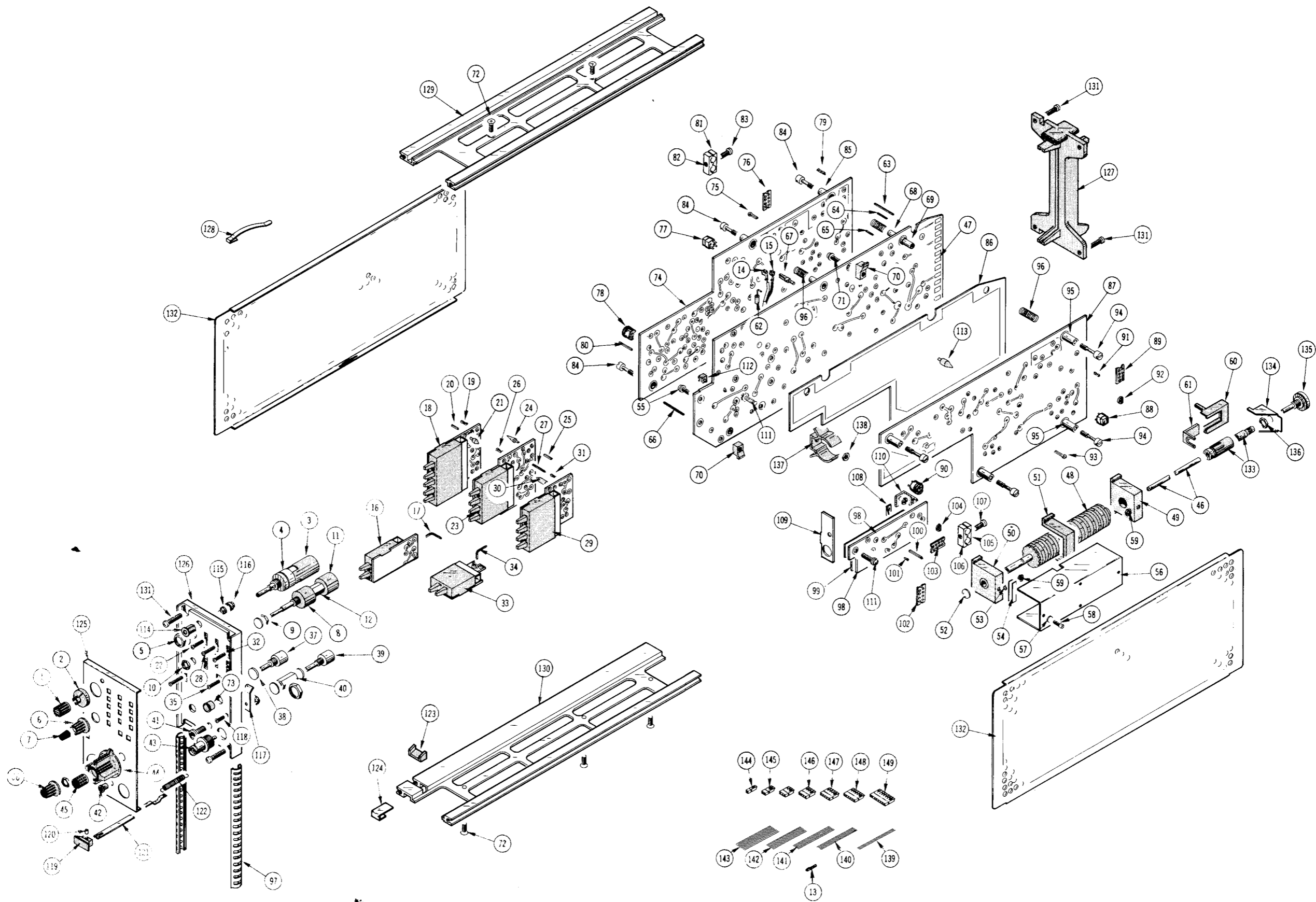

+

+

ACCESSORIES

Fig. & Index No.	Tektronix Part No.	Serial/Model No.		Q t y						Description
		Eff	Disc		1	2	3	4	5	
2-	070-1579-00			1						MANUAL, instruction (B205000 up)

7B70 TIME BASE (B205000 up)

REPACKAGING

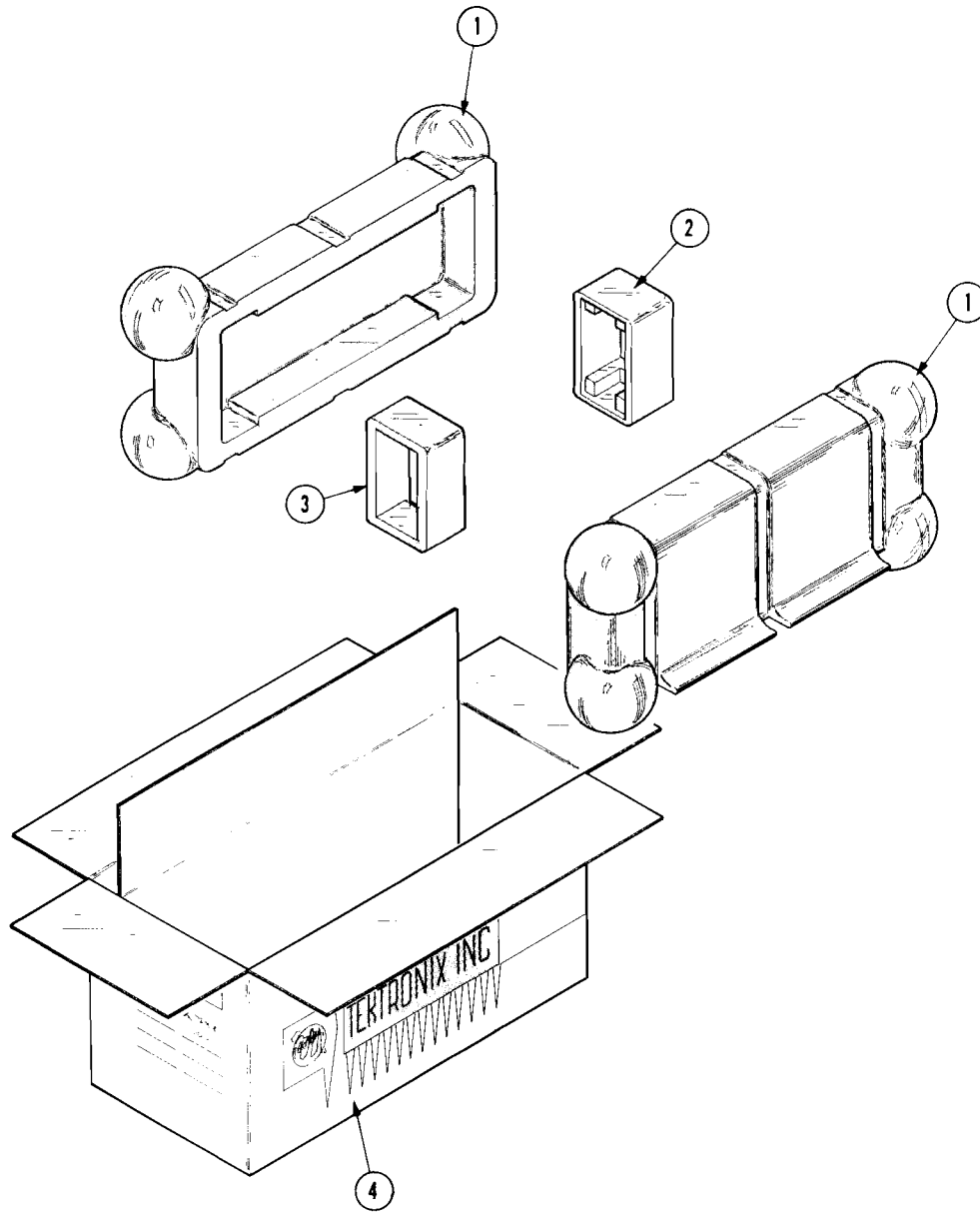

Fig. & Index No.	Tektronix Part No.	Serial/Model No.		Qty	1	2	3	4	5	Description
		Eff	Disc							
2-	065-0125-00			1						CARTON ASSEMBLY
-1	004-0241-00			2						carton assembly incl:
-2	004-0242-00			1						CASE HALF
-3	004-0243-00			1						END CAP, rear
-4	004-0748-00			1						END CAP, front
				1						CARTON

A+

MANUAL CHANGE INFORMATION

At Tektronix, we continually strive to keep up with latest electronic developments by adding circuit and component improvements to our instruments as soon as they are developed and tested.

Sometimes, due to printing and shipping requirements, we can't get these changes immediately into printed manuals. Hence, your manual may contain new change information on following pages.

A single change may affect several sections. Since the change information sheets are carried in the manual until all changes are permanently entered, some duplication may occur. If no such change pages appear following this page, your manual is correct as printed.

SERVICE NOTE

Because of the universal parts procurement problem, some electrical parts in your instrument may be different from those described in the Replaceable Electrical Parts List. The parts used will in no way alter or compromise the performance or reliability of this instrument. They are installed when necessary to ensure prompt delivery to the customer. Order replacement parts from the Replaceable Electrical Parts List.

CALIBRATION TEST EQUIPMENT REPLACEMENT

Calibration Test Equipment Chart

This chart compares TM 500 product performance to that of older Tektronix equipment. Only those characteristics where significant specification differences occur, are listed. In some cases the new instrument may not be a total functional replacement. Additional support instrumentation may be needed or a change in calibration procedure may be necessary.

Comparison of Main Characteristics

DM 501 replaces 7D13		
PG 501 replaces 107	PG 501 - Risetime less than 3.5 nsec into 50 Ω .	107 - Risetime less than 3.0 nsec into 50 Ω .
108	PG 501 - 5 V output pulse; 3.5 nsec Risetime.	108 - 10 V output pulse; 1 nsec Risetime.
111	PG 501 - Risetime less than 3.5 nsec; 8 nsec Pretrigger pulse delay.	111 - Risetime 0.5 nsec; 30 to 250 nsec Pretrigger Pulse delay.
114	PG 501 - ± 5 V output.	114 - ± 10 V output. Short proof output.
115	PG 501 - Does not have Paired, Burst, Gated, Delayed & Undelayed pulse mode; ± 5 V dc Offset; short proof output. Has ± 5 V output.	115 - Paired, Burst, Gated, Delayed & Undelayed pulse mode; ± 10 V output. Short proof output.
PG 502 replaces 107		
108	PG 502 - 5 V output	108 - 10 V output.
111	PG 502 - Risetime less than 1 nsec; 10 nsec Pretrigger pulse delay.	111 - Risetime 0.5 nsec; 30 to 250 nsec Pretrigger pulse delay.
114	PG 502 - ± 5 V output.	114 - ± 10 V output. Short proof output.
115	PG 502 - Does not have Paired, Burst, Gated, Delayed & Undelayed pulse mode; ± 5 V output. Short proof output.	115 - Paired, Burst, Gated, Delayed & Undelayed pulse mode; ± 10 V output. Short proof output.
2101	PG 502 - Does not have Paired, Delayed, Undelayed and output locked mode; ± 5 V output.	2101 - Paired, Delayed, Undelayed and output locked on mode; 10 V output.
PG 506 replaces 106	PG 506 - Positive-going trigger output signal at least 1 V; High Amplitude, 60 V output.	106 - Positive and Negative-going trigger output signal, 50 nsec and 1 V; High Amplitude output, 100 V.
067-0502-01	PG 506 - Does not have chopped feature.	0502-01 - Comparator output can be alternately chopped to a reference voltage.
SG 503 replaces 190, 190A, 190B	SG 503 - Amplitude range 5 mV to 5.5 V p-p.	190B - Amplitude range 40 mV to 10 V p-p.
191	SG 503 - Frequency range 250 kHz to 250 MHz.	191 - Frequency range 350 kHz to 100 MHz.
067-0532-01	SG 503 - Frequency range 250 kHz to 250 MHz.	0532-01 - Frequency range 65 MHz to 500 MHz.
TG 501 replaces 180, 180A	TG 501 - Marker outputs, 5 sec to 1 ns. Sinewave available only at 5,2, and 1 ns. Trigger output - slaved to marker output from 5 sec through 100 ns. Only one time-mark can be generated.	180A - Marker outputs, 5 sec to 1 μ s. Sinewave available at 5, 10, and 50 MHz. Trigger pulses 1, 10, 100 Hz; 1,10, and 100 kHz. Multiple time-marks can be stacked.
181	TG 501 - Marker outputs, 5 sec to 1 ns. Sinewave available only at 5, 2, and 1 ns.	181 - Marker outputs, 1, 10, 100, 1000, and 10,000, plus 10 MHz sinewave.
2901	TG 501 - Marker outputs, 5 sec to 1 ns. Sinewave available only at 5, 2, and 1 ns. Trigger output - slaved to marker output from 5 sec through 100 ns. Only one time-mark can be generated.	2901 - Marker outputs, 5 sec to 0.1 μ s. Sinewave available at 5, 10, and 50 ns. Separate trigger pulses, from 5 sec to 0.1 μ s. Multiple time-marks can be stacked.

@