

### Temperatur-Feuchte-Sensor

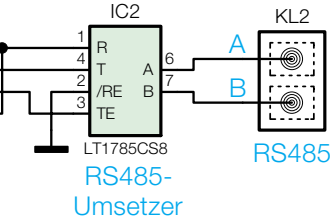
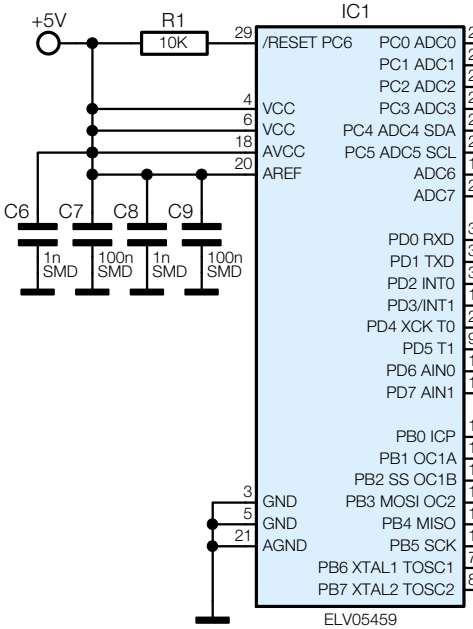
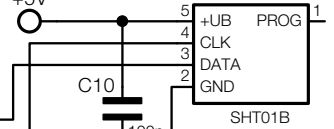

**Bild 1: Schaltung des JCU 10 TFS**