

**Bild 1: Schaltbild der Basisplatte des EM 1000-HSM**

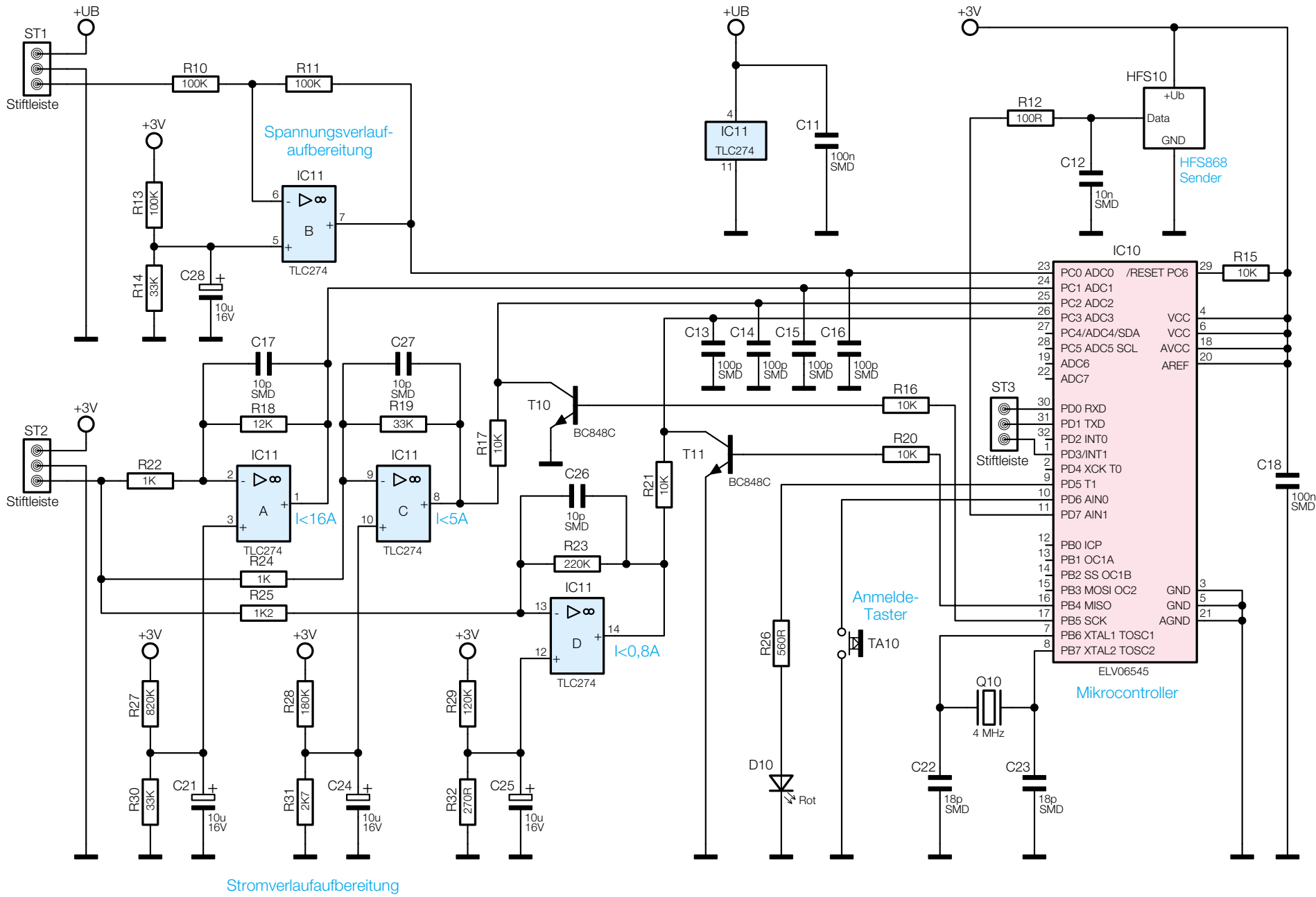

**Bild 2:**  
Schaltbild der Steuerplatine des EM 1000-HSM