

Bild 8: Spannungsversorgung des Sound-Recorders

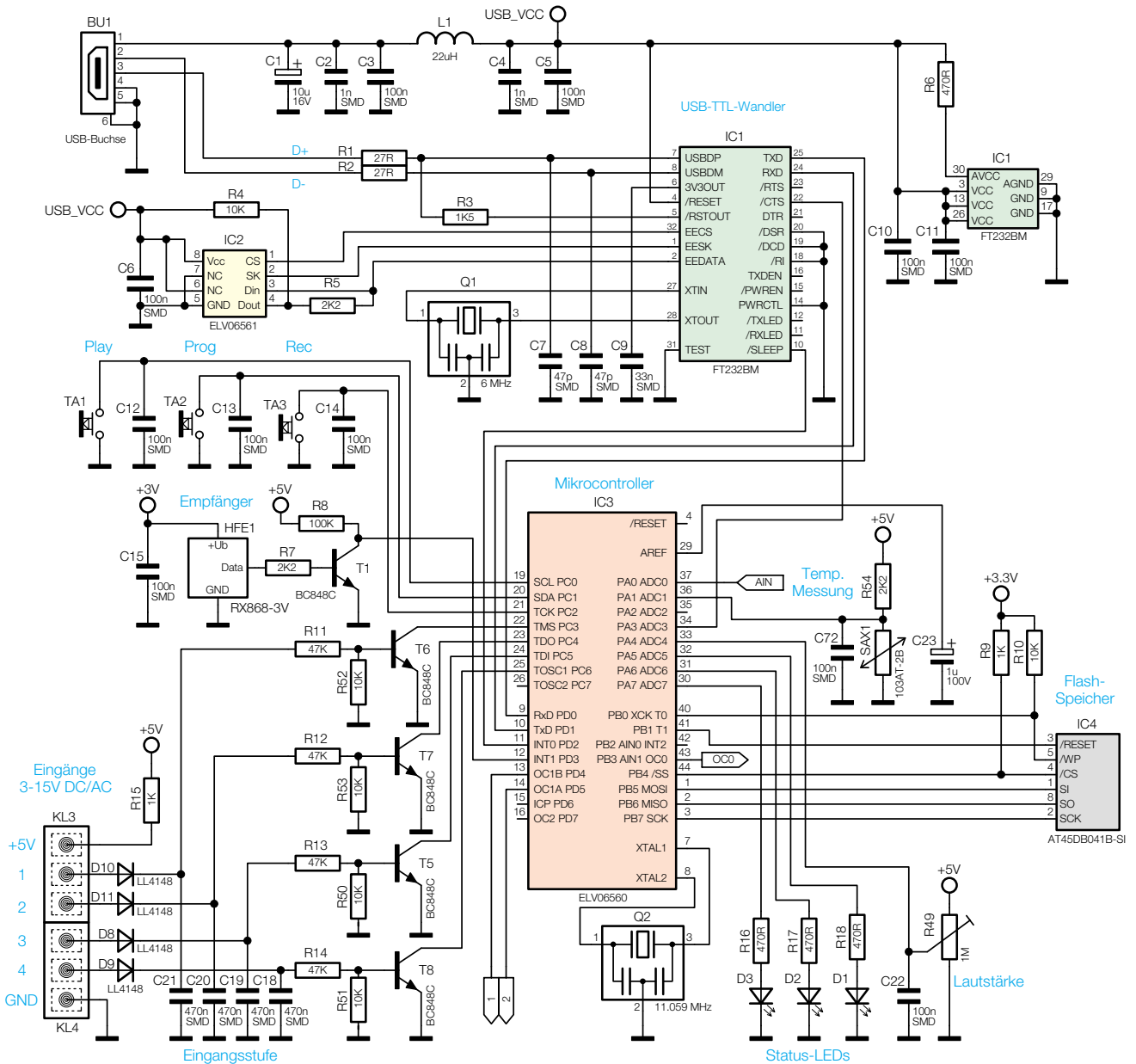

Bild 9: Schaltbild des Digitalteils

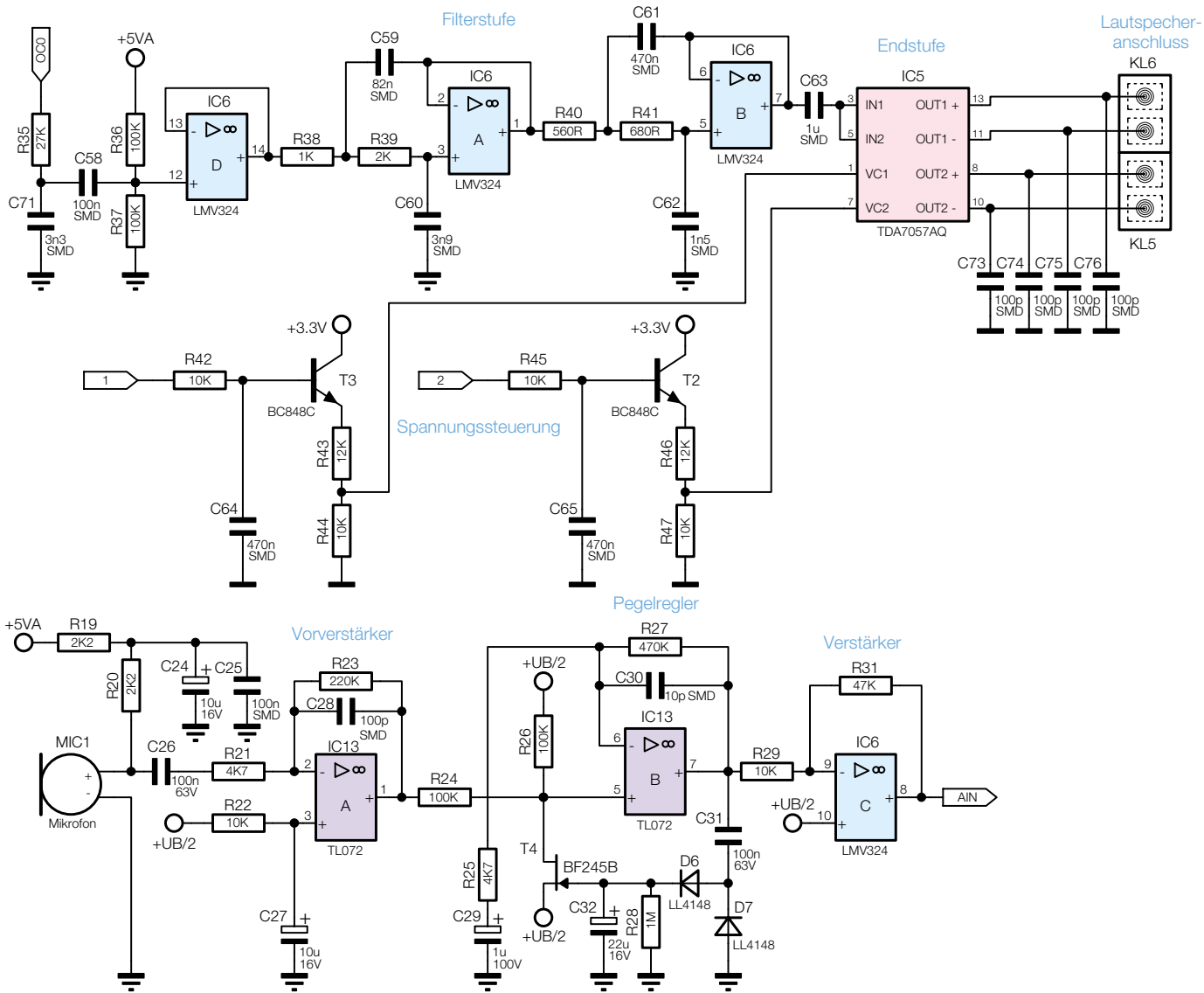

Bild 10: Schaltung des Analogteils