

11V - 14V / DC

**Bild 4:**  
**Schaltbild des**  
**Sendemoduls TIR 100T**

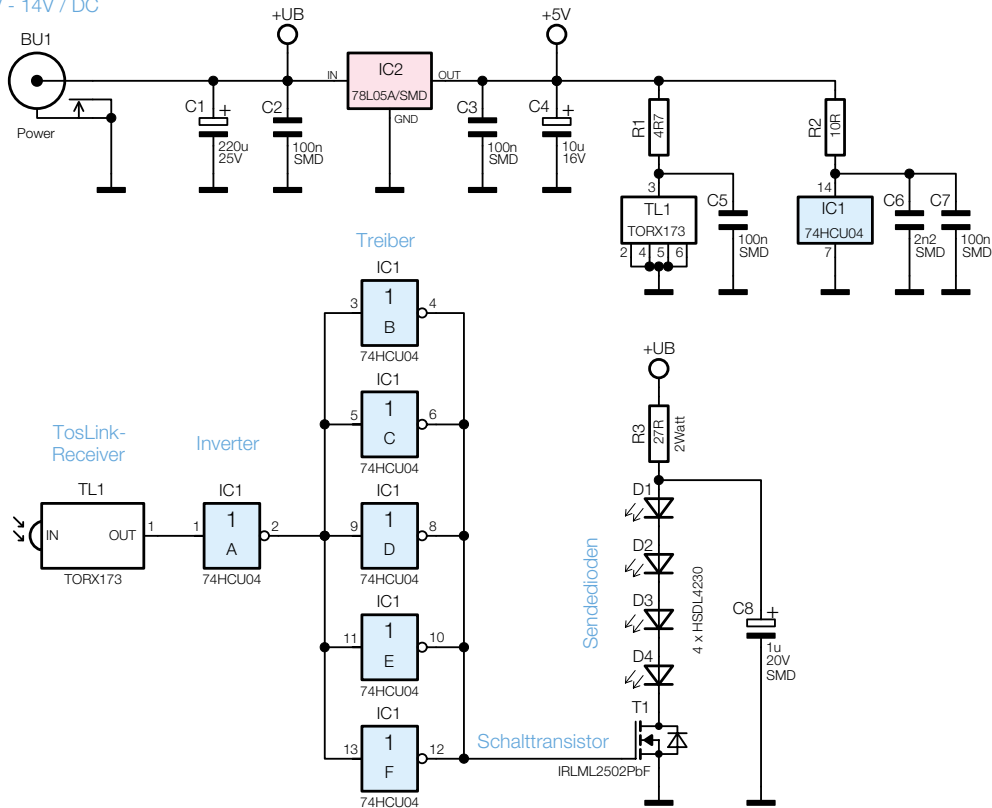

8V - 16V / DC

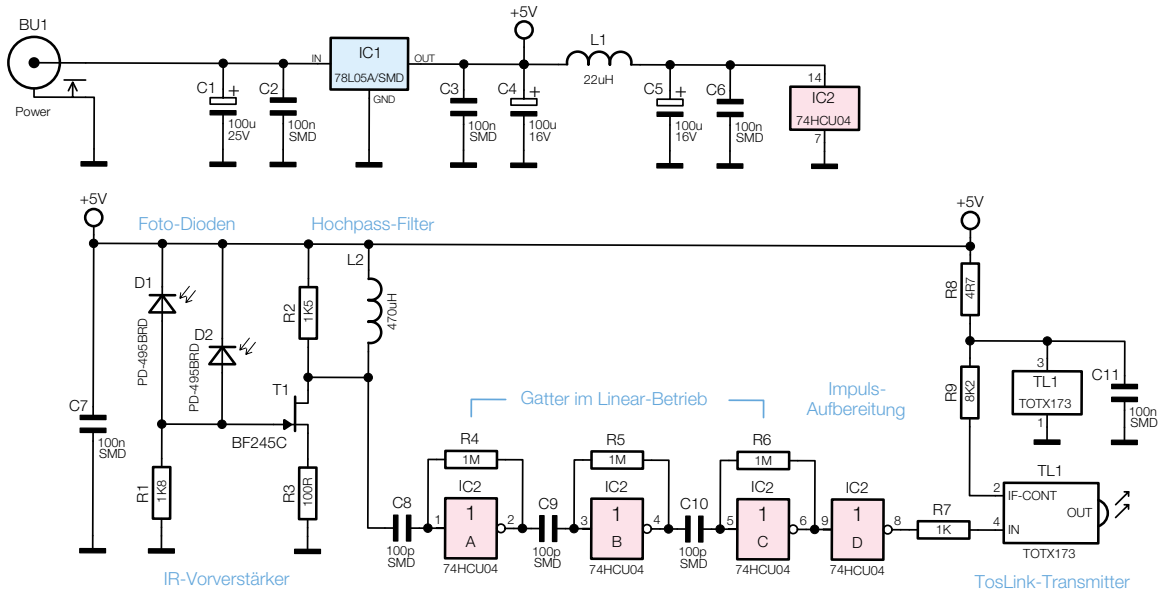

**Bild 5: Schaltbild der Empfangseinheit TIR 100R**